

**TRIBHUVAN UNIVERSITY**  
**INSTITUTE OF ENGINEERING**  
**PULCHOWK CAMPUS**

**A FINAL YEAR PROJECT REPORT ON**  
**COMPENSATION FOR REACTIVE POWER AND HARMONIC CURRENTS**  
**DRAWN BY NON-LINEAR LOAD IN PV-MICRO HYDRO GRID**

**SUPERVISORS:**

**Prof. Dr. Indraman Tamrakar**

**Submitted by:**

**Ajay Thapa (075BEL004)**

**Raisha Karmacharya (075BEL033)**

**Raj Krishna Nepal (075BEL034)**

**Sanket Khatiwada (075BEL041)**

**Submitted To:**

**DEPARTMENT OF ELECTRICAL ENGINEERING**

**APRIL 27, 2023**

**TRIBHUVAN UNIVERSITY**  
**INSTITUTE OF ENGINEERING**  
**PULCHOWK CAMPUS**  
**DEPARTMENT OF ELECTRICAL ENGINEERING**

The undersigned certify that they have read and recommend to the Institute of Engineering for acceptance, a project entitled “ **COMPENSATION FOR REACTIVE POWER AND HARMONIC CURRENT DRAWN BY NON-LINEAR LOAD IN PV-MICROHYDRO GRID** “ submitted by Ajay Thapa, , Raisha Karmacharya , Raj Krishna Nepal and Sanket Khatiwada in partial fulfillment of the requirements for the degree of Bachelor of Electrical Engineering.



---

Prof. Dr. Indraman Tamrakar  
Supervisor  
Department of Electrical Engineering  
Pulchowk Campus



---

Mr. Rajan Dhakal  
External Examiner  
Director  
DCS, Bagmati Provincial Office  
Nepal Electricity Authority



---

Mr. Yuba Raj Adhikari  
Head of Department  
Department of Electrical Engineering  
Pulchowk Campus

Date: April 27.2023

## **COPYRIGHT ©**

The authors have agreed that the Library, Department of Electrical Engineering, Pulchowk Campus and Institute of Engineering may make this report freely available for inspection. Moreover, the authors have agreed that permission for extensive copying of this project report for scholarly purpose may be granted by the supervisor who supervised the project work recorded here in or, in their absence, by the Head of Department where in the project report was done. It is understood that the recognition will be given to the author of this report and to the Department of Electrical Engineering, Central Campus, Pulchowk and Institute of Engineering in any use of the material of this project report. Copying or publication or the other use of this report for financial gain without approval of the Department of Electrical Engineering, Central Campus Pulchowk and author written permission is prohibited.

Request for permission to copy and make any other use of the material in this report in whole or in part should be address to:

The Head

Department of Electrical Engineering

IOE, Pulchowk Campus

Lalitpur, Nepal

## **Acknowledgement**

First and foremost, we would like to express our sincere gratitude to our Supervisor **Prof. Dr. Indraman Tamrakar** for his patience, guidance, and continuous support in our project. We are grateful for the expertise, constructive feedback, and encouragement, which has helped us achieve our goals.

We would like to express our deep respect to Head of Electrical Engineering Department for their academic and administrative support.

Our sincere thanks goes to all professor and lecturers of department for their precious suggestions and kind support throughout the project duration.

Last but not the least; we extend our special thanks to all of the staff of the department and our friends and families for their cooperation. We are also very thankful to the authors of various research articles that we referred during the project.

Any sort of suggestions or criticism will be highly appreciated and acknowledged.

Ajay Thapa

Raisha Karmacharya

Sanket Khatiwada

Raj Krishna Nepal

## **ABSTRACT**

This project proposes a method to improve the power quality of a PV micro hydro grid by utilizing instant PQ theory and hysteresis current control band logic. The main goal is to mitigate harmonics and ensure reliable utility power supply. This is achieved through the use of a shunt active power filter, which acts as a current source and cancels out harmonics by injecting equal and opposite harmonic components at the grid connection point.

The proposed system includes a shunt active power filter with an inverter that employs the instantaneous PQ theory algorithm to generate reference current. The hysteresis band current control logic utilizes the reference current in the a-b-c frame to generate appropriate gate signals for the inverter, ensuring that the current drawn from the inverter tracks the reference currents within a specified band, thereby compensating for the non-linear load.

The MATLAB-Simulink Toolbox is used to simulate the shunt active power filter in order to demonstrate its efficiency and adaptability. The simulation considers two different types of loads to validate the effectiveness of the proposed scheme. The simulation results are analyzed and evaluated.

Overall, the project aims to design a system that can compensate for reactive power and harmonic current consumed by the load. By ensuring nearly sinusoidal current in proportion to the active power, the system aims to improve the power quality of the PV micro hydro grid.

# Table of Contents

COPYRIGHT © .....	ii
Acknowledgement .....	iii
ABSTRACT .....	iv
LIST OF FIGURES.....	vii
LIST OF SYMBOLS AND ABBREVIATIONS.....	viii
CHAPTER ONE: INTRODUCTION.....	1
1.1 BACKGROUND.....	1
1.2 Problem Statement.....	3
1.3 Objective.....	3
1.4 Scope and Limitation .....	3
1.5 Report organization .....	4
CHAPTER TWO: LITERATURE REVIEW.....	5
2.1 Review of papers .....	5
2.2 Related Theory.....	6
CHAPTER THREE: METHODOLOGY.....	16
3.1 Proposed Scheme .....	16
3.2 Overview .....	17
3.3 Simulation Tool .....	18
3.4 Development of nonlinear load.....	18
3.5 Inside Nonlinear load subsystem.....	19
3.6 Development of Grid Connected PV with MPPT .....	19
3.7 PV MPPT subsystem.....	20
3.8 PV Inverter Hysteresis Control subsystem.....	21
3.9 Development of Micro Hydro Plant.....	22
3.10 Development of Discrete Resistance ELC .....	22
3.11 Development of Shunt Active Power Filter model .....	23
3.12 Overall model.....	24
CHAPTER FOUR: RESULT AND DISCUSSION.....	25
4.1 Nonlinear Waveform Current Output .....	25
4.2 PV Array Characteristic Curve .....	25
4.3 PV System Output Waveforms model .....	26
4.4 Output waveforms of MHP model.....	26

4.5 DC link Capacitor Voltage .....	28
4.6 Output waveforms of Overall model Without SAPF.....	28
4.7 Output waveforms of Overall model with SAPF .....	29
4.8 THD Analysis of Source Current Without SAPF.....	30
4.9 THD Analysis of Source Current With SAPF .....	30
CHAPTER FIVE .....	31
CONCLUSION .....	31
References .....	32
APPENDIX.....	33
APPENDIX A: Perturbation and Observation Algorithm .....	33
APPENDIX B: MATLAB function code for MPPT.....	34

## LIST OF FIGURES

Figure 1. 1 MHP Plant and its daily load curve .....	1
Figure 2. 1 Current vs voltage graph for non-linear load .....	6
Figure 2. 2 Block Diagram Showing Reference current generation using P-Q theory.....	11
Figure 2. 3 Block diagram of PQ theory.....	11
Figure 2. 4 Control logic of Hysteresis Band Current Control technique .....	14
Figure 3. 1 Proposed scheme .....	16
Figure 3. 2 Schematic diagram shunt active power filter based on instantaneous P-Q theory .....	16
Figure 4. 1 Non-Linear Load System .....	18
Figure 4. 2 Non-Linear Load Subsystem.....	19
Figure 4. 3 Voltage and Current Waveform of Non-Linear Load .....	25
Figure 4. 4 PV with Perturbation and Observation based MPPT Algorithm.....	19
Figure 4. 5 MPPT Subsystem .....	20
Figure 4. 6 Perturbation and Observation Flowchart.....	33
Figure 4. 7 Inverter hysteresis control logic .....	21
Figure 4. 8 PV system output waveforms.....	26
Figure 4. 9 Simulation model of micro-hydro plant .....	22
Figure 4. 10 Simulation model of Electronic Load Controller .....	22
Figure 4. 11 Output voltage waveform of MHP .....	26
Figure 4. 12 Output power waveform of MHP.....	27
Figure 4. 13 Output waveform of rotor speed of MHP .....	27
Figure 4. 14 Shunt Active Power Filter model .....	23
Figure 4. 15 DC link capacitor voltage.....	28
Figure 4. 16 Overall model .....	24
Figure 4. 17 Output waveforms of Overall model Without SAPF .....	28
Figure 4. 18 Output waveforms of Overall model with SAPF .....	29
Figure 4. 19 THD Analysis of Source Current Without SAPF.....	30
Figure 4. 20 THD Analysis of Source Current With SAPF.....	30

## **LIST OF SYMBOLS AND ABBREVIATIONS**

ELC	Electronic load controller
MHP	Micro hydro plant
MPPT	Maximum power point tracking
PCC	Point of common coupling
PV	Photo voltaic
PWM	Pulse Width Modulation
SAPF	Shunt active power filter
SG	Synchronous generator

# CHAPTER ONE: INTRODUCTION

## 1.1 BACKGROUND

In context of Nepal, hydro power plants ranging from capacity of 10 kW to 100kW are classified as Micro Hydro Power (MHP) plant.

As grid extension to rural areas with few populations is not economical due to high cost of transmission line and power loss in the line, the concept of MHP plant is very popular in Rural areas of Nepal for electrification.

Generally, MHP plant is an isolated plant used in rural area where there is no power supply from national grid. Electronic Load Controller (ELC) is used for speed control instead to conventional speed governor to reduce the cost of plant.

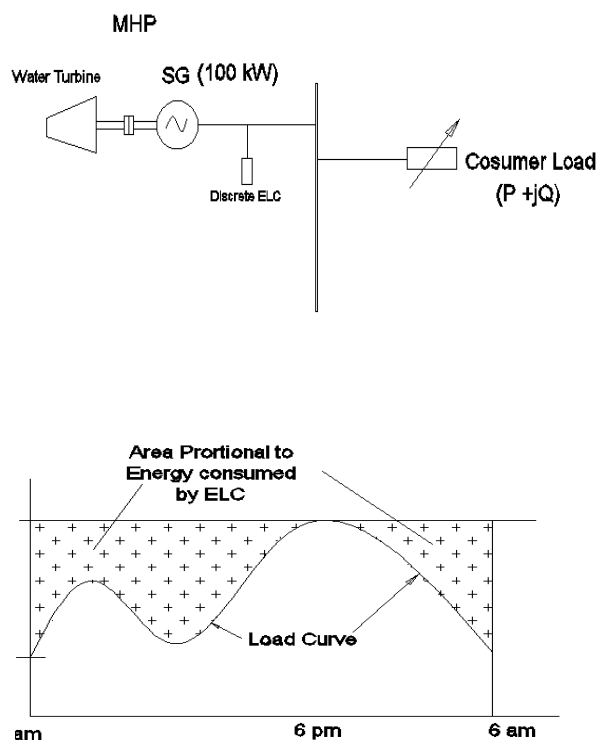

Figure 1. 1 MHP Plant and its daily load curve

So that:  $P_{\text{SynchGen}} = P_{\text{Load}} + P_{\text{ELC}}$  all the time and speed remain constant.

The shaded area represents the energy wasted in the dump load. As all the energy that can be supplied by the MHP plant is not fully utilized, the load factor of such plant is very low. The load factor can be increased by encouraging rural industry during day time. If the sum of maximum demand of rural industry and consumers load at day time is greater than the capacity of existing MHP, PV plant can be added to supply extra power as shown in fig below:

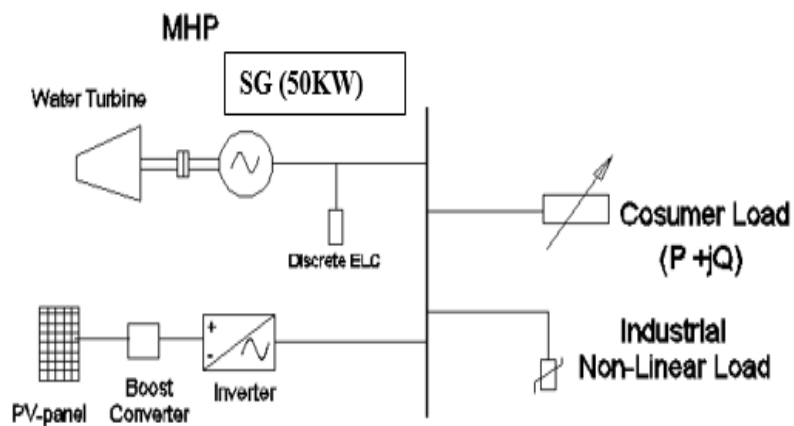

Figure 1.2 MHP Plant with PV source connected to consumer and non-linear load

The industrial load could be inductive as well as non-linear.

Non-linear load draws current in abrupt short pulses. These short pulses distort the current waveform which in turn generates Harmonics

Harmonics create problems such as:

- a) Poor power factor
- b) Overheating of devices
- c) Low efficiency
- d) Nuisance tripping of Circuit breakers
- e) Subsequent current interruptions.

In a PV micro hydro grid system, the PV source alone is not be capable of handling the reactive power and harmonic currents produced by non-linear loads because of its PV systems typically have limited capability to provide reactive power support. Therefore, a synchronous generator is often employed in such systems to address these power quality issues. It operates in parallel with the PV source and works as a supplementary power source. It actively generates reactive power to compensate for the reactive power demand of the load. Additionally, the synchronous generator can help counteract the harmonic currents drawn by the non-linear load, ensuring a more stable and sinusoidal power supply.

## **1.2 Problem Statement**

- The reactive and non-linear load in the PV-Hydro combined system affects the power quality of isolated plant.
- If the load consumes significant reactive power, the synchronous generator is bound to generate the reactive power at the expense of reduction in active power generation so that VA burden does not exceeds the rating of generator's capacity.
- If the load draws significant number of harmonic currents, the winding of the generator gets overheated due to skin effect and overall power factor of the system becomes poor.

## **1.3 Objective**

- To develop the simulation model of PV-Hydro isolated Micro-grid system and simulation model of combined reactive power and harmonic current compensator for the compensation of reactive power and harmonic current drawn by a non-linear load.

## **1.4 Scope and Limitation**

- Maintain the quality of the grid.
- Investigate potential applications of the developed system in various micro-hydro plants.
- Develop an innovative PQ theory-based controller that can improve the working and efficiency of system.
- Evaluate the performance through simulation results.

## 1.5 Report organization

- This project constitutes five chapters. The first chapter covers the statement of the problem, objective of this project, scopes and its limitations.
- Chapter two of the project encompasses a comprehensive literature review, focusing on theoretical frameworks, scholarly articles, publications from IEEE conferences or transactions, and notable books published by major publishers. The aim of this review is to gather existing information and previous research outcomes conducted by other researchers in the field. By examining the available literature, the project seeks to build upon the existing knowledge and contribute to the body of research in a meaningful way.
- Chapter three of the project presents the methodology employed for the implementation of the PQ theory algorithm and hysteresis band control logic. The primary objective is to utilize these approaches for compensating reactive power and harmonic current. The chapter serves as a guide to understanding the practical aspects of the proposed approach and how it addresses the issues of compensation for reactive power and harmonic current.
- Chapter four presents the simulation results as well as the discussion of the compensated system
- Chapter five concludes the result.

## CHAPTER TWO: LITERATURE REVIEW

### 2.1 Review of papers

The increased utilization of power electronics devices by end users, thanks to advancements in semiconductor technology, has introduced a range of challenges. These challenges include issues such as generation of harmonic, low power factor, system efficiency reduction, potential disruptions to consumers, and device overheating. The widespread adoption of power electronics devices has given rise to these problems, highlighting the need for effective solutions to mitigate their adverse effects on power systems and ensure optimal performance and reliability. The utilization of non-linear loads, which generate harmonics, is a significant factor contributing to power quality issues in distribution systems. These non-linear loads can introduce disturbances and fluctuations in the electrical waveform, leading to problems such as voltage distortion, increased losses, reduced system efficiency, and interference with sensitive equipment. Addressing these power quality issues is of paramount importance, as they have the potential to escalate and become more pronounced in the future. Recognizing the significance of this issue, it becomes imperative to implement effective measures to mitigate harmonics and ensure a high-quality power supply for various applications. To mitigate power quality issues, there are primarily two methods that can be employed. The first approach is load conditioning, which aims to make the equipment immune to harmonics and power disturbances, but its feasibility and practicality may vary depending on the specific circumstances and constraints. Power line conditioning, as an alternative solution, involves the installation of a line conditioning system at the point of common coupling (PCC) to mitigate power quality issues caused by harmonics and power disturbances when load conditioning is not feasible or practical. Harmonic production and problems with reactive power disturbance were traditionally addressed by the use of passive filters. However, they had significant problems such resonance issues, big size, fixed compensating features, source impedance effects on performance, etc., making this approach less appealing. Sasaki and Machida later introduced the idea of an active power filter in 1971. [1] Shunt active power filters operate as current sources, injecting harmonic components generated by the load with

a phase shift of  $180^\circ$  to mitigate the effects of harmonics on the power system. By injecting these opposing harmonic components, the shunt active power filter effectively cancels out the harmonic currents, reducing or eliminating their impact on the power system. This approach ensures a cleaner and more stable power supply by actively compensating for the harmonics generated by non-linear loads. [2]

Renewable energy is the key contributor of the emerging technology. Power quality aspect plays a significant role in grid connected system. [3] The development and implementation of a SAPF specifically designed for a three-phase four-wire system with a balanced and undistorted supply voltage can significantly contribute to improving power quality problems in electrical systems. This technology enables compensation for harmonic currents, reactive power, and zero sequence currents, ensuring a higher level of power quality and reliability in the electrical system. [4]

## 2.2 Related Theory

### 2.2.1 Non-linear load

If a load's impedance varies depending on the voltage applied, it is known to be non-linear. Even when coupled to a sinusoidal voltage, the non-linear load's current draw won't be sinusoidal due to the fluctuating impedance. These harmonic currents in these non-sinusoidal currents interact with the power distribution system's impedance to produce voltage distortion, which can impact both the distribution system's hardware and the loads connected to it. [5]

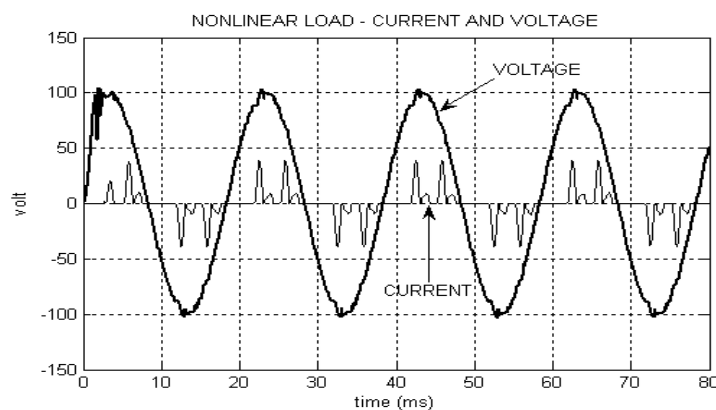

Figure 2. 1 Current vs voltage graph for non-linear load

### 2.2.2 Active Power Filters

Active power filters generate harmonic currents that are equal in magnitude but phase-shifted by  $180^\circ$  compared to the harmonic currents produced by the load, allowing for effective compensation and cancellation of harmonics. [1] One of the notable advantages of active filters is their inherent ability to automatically adapt to variations in the network conditions and load fluctuations, ensuring continuous and efficient compensation of power quality issues. This adaptability is crucial in maintaining effective harmonic and reactive power compensation in dynamic electrical systems. Unlike passive filters, which are typically designed to target specific harmonic frequencies, active filters can address a wide range of harmonic orders. Moreover, active filters exhibit minimal susceptibility to major changes in network characteristics, thereby mitigating the risk of resonance between the filter and network impedance. This characteristic enhances the overall stability and effectiveness of the power quality compensation process. [6]

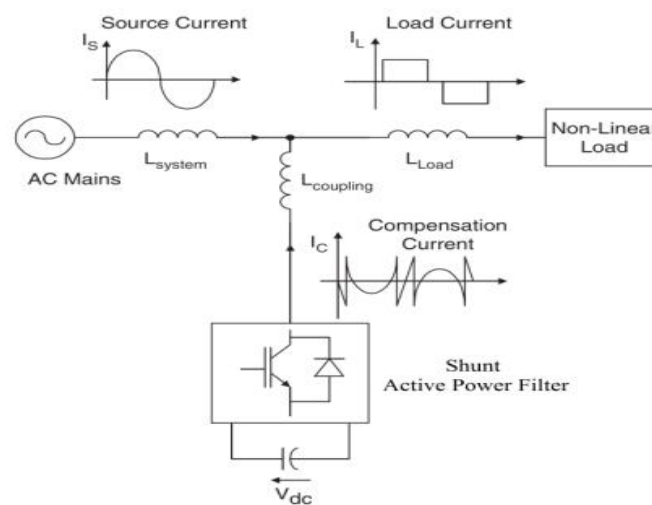

Figure 2. 2 A basic scheme of SAPF

The shunt active power filter functions as a current source, actively generating and injecting harmonic currents that are equal in magnitude but opposite in phase to the harmonic currents produced by the load, effectively compensating for the harmonics and improving power quality.

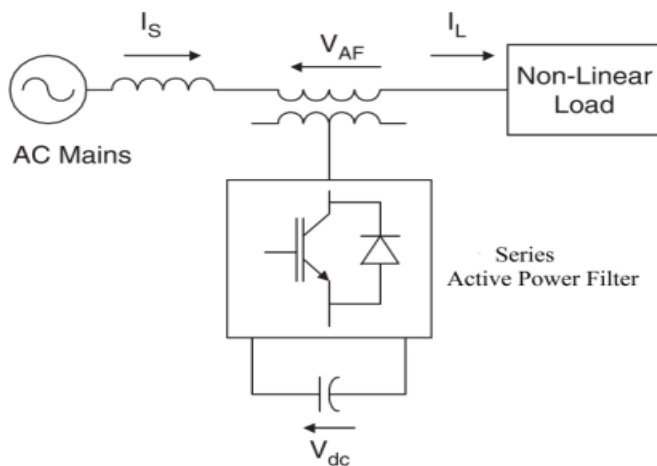

Figure 2. 3 Basic scheme of series active power filter

The series active filter operates as a controlled voltage source, injecting a compensating voltage in series with the supply voltage. By doing so, it regulates the voltage, compensates for voltage variations such as sags and swells, and mitigates harmonic components, resulting in improved power quality within the electrical system.[1]

### 2.2.3 MPPT (Maximum Power Point Tracking)

Maximum Power Point Tracking (MPPT) is a technique commonly used with variable power sources, such as solar panels, to optimize energy extraction as conditions change. The MPPT method involves modifying the load characteristic as the environment changes. It focuses on adjusting the operating conditions of the power source itself to maximize energy extraction. The MPPT controller monitors the voltage and current output of the solar panel and continuously calculates the optimal operating parameters necessary to achieve the maximum power output. By dynamically adjusting the operating conditions, the MPPT controller ensures that the solar panel operates at its peak efficiency, maximizing the power generation from the available sunlight. The simplicity and efficiency of the Perturb and Observe (P&O) method make it popular for MPPT applications. [7].

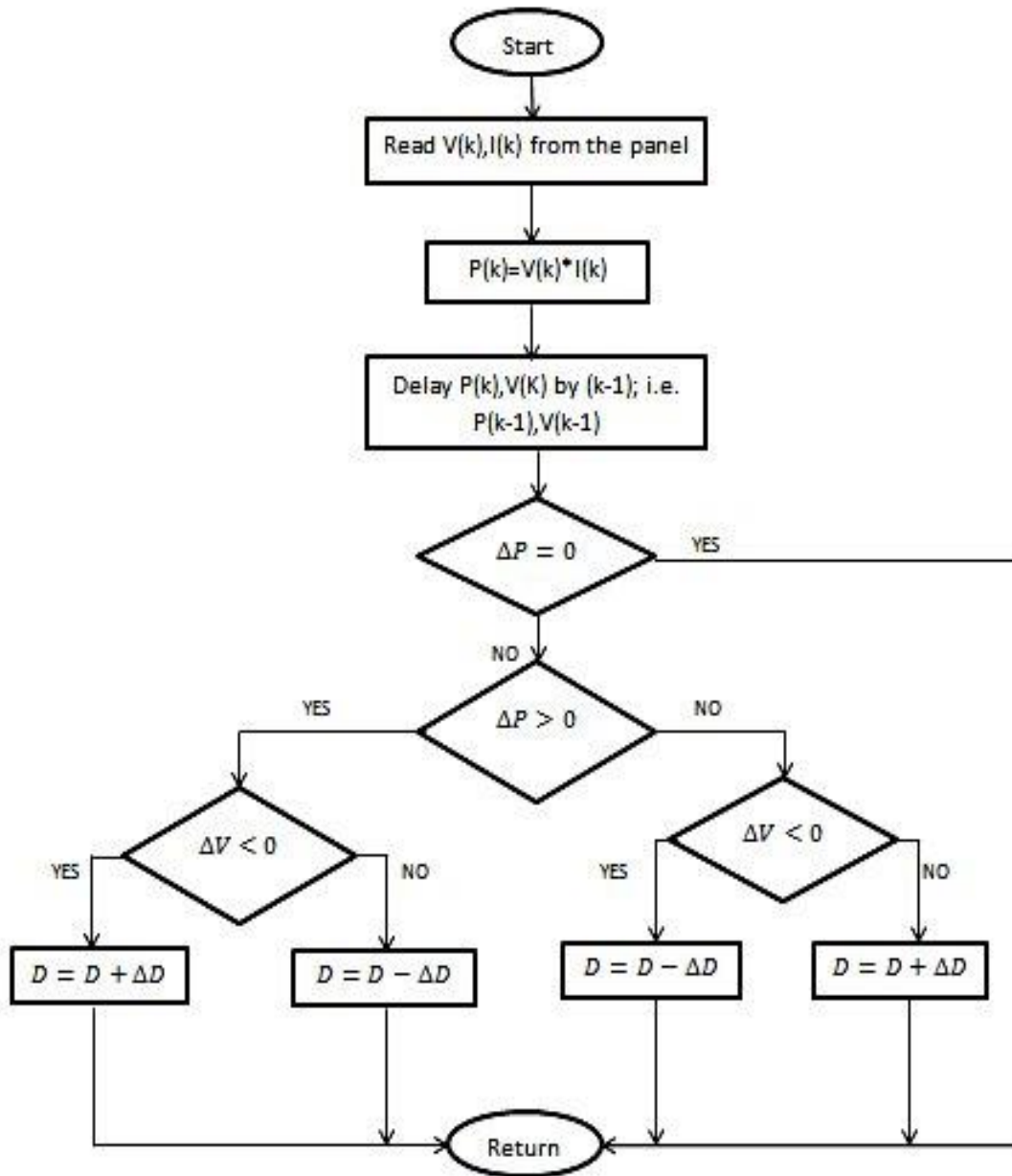

Figure 2.4 Flowchart of identifying MPP

Above figure shows the algorithm for MPPT system. Here  $D$  is the reference voltage for which power is calculated and then increased or decreased to get to MPP. The loop of the system continues till the MPP is tracked and continuously works to keep power output at maximum point.

## 2.2.4 Three Phase Voltage Source Inverter (VSI)

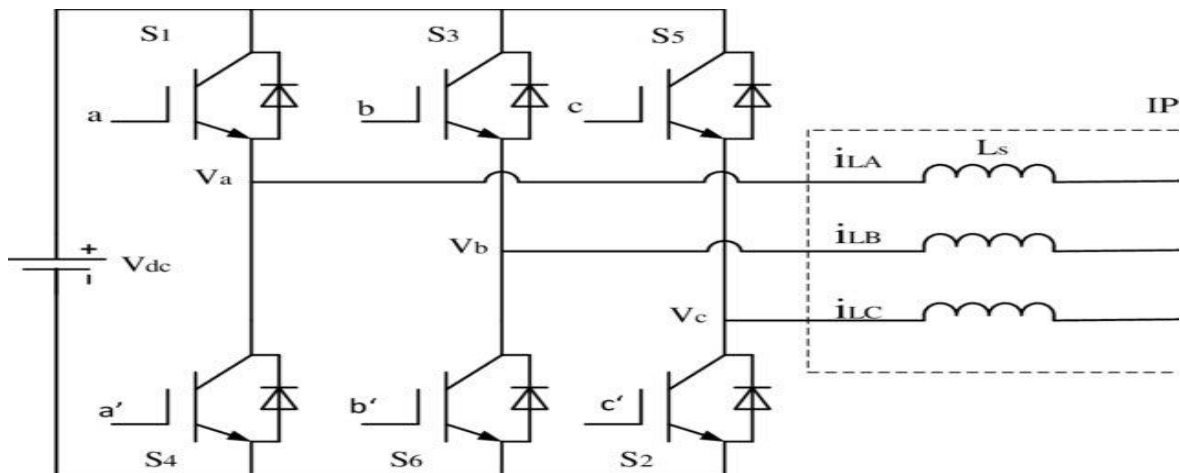

Figure 2. 5 Three Phase VSI with L-filter

A three-phase voltage source inverter (VSI) is a power electronic device that converts DC voltage into AC voltage with variable frequency and magnitude. It is used in applications such as motor drives, renewable energy systems, and grid-tied inverters. The use of IGBTs or MOSFETs in the VSI provides high-speed switching capability and efficient operation. These semiconductor devices have low conduction losses and can handle high currents, making them suitable for various applications.

The output waveform of a three-phase VSI is typically a pulse-width modulated (PWM) waveform. PWM is a modulation technique that allows the control of the output voltage magnitude by adjusting the switching frequency and duty cycle of the semiconductor switches. The three-phase output voltage of the VSI can be either sinusoidal or non-sinusoidal depending on the type of modulation technique used. A three-phase VSI plays a crucial role in enabling the conversion of DC voltage generated by a PV array into AC voltage that can be fed into the grid, facilitating the utilization of solar energy for grid-connected applications. The VSI provides better control over the output waveform, allowing the system to operate at optimal levels and minimizing the impact of grid disturbances. The VSI is highly efficient and can handle high power levels, making it suitable for large-scale PV systems.

### 2.2.5 Instantaneous PQ THEORY

"The Generalized Theory of the Instantaneous Reactive Power in Three-Phase Circuits" is commonly known as the Instantaneous P-Q theory. It is a theoretical framework that provides a comprehensive analysis of reactive power and power quality in three-phase electrical systems. The theory was developed to extend the concepts of active and reactive power to three-phase systems, allowing for a more accurate and detailed assessment of power flows and power quality issues. It is based on the concept of instantaneous power, which provides a more accurate representation of power characteristics. [8]

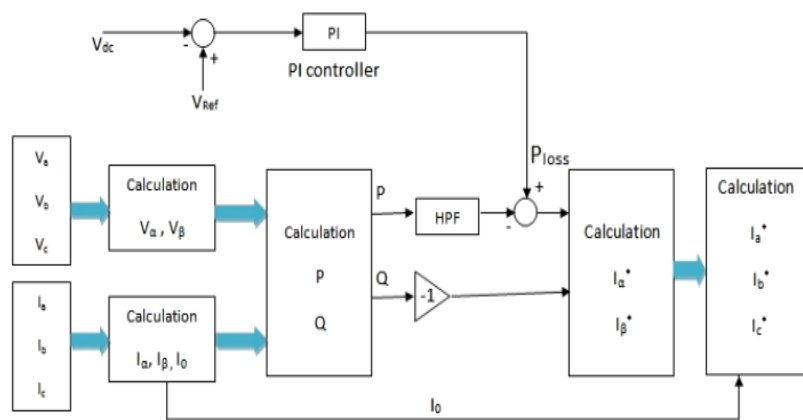

Figure 2. 6 Block Diagram Showing Reference current generation using P-Q theory

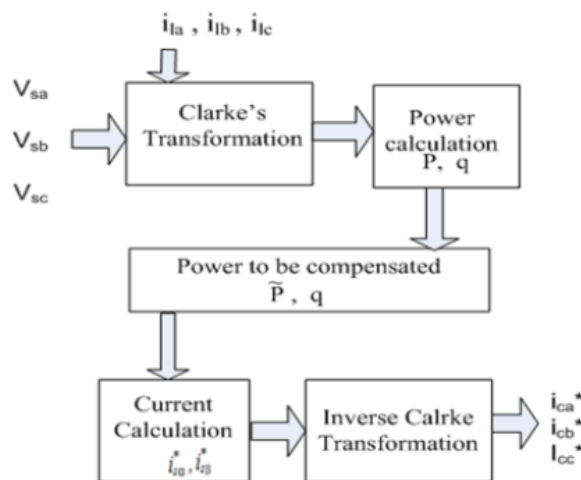

Figure 2. 7 Block diagram of PQ theory

Clarke's transformation, also known as the Clarke transformation or the  $\alpha\beta 0$  transformation, is a technique that allows the conversion of the three-phase quantities (a-b-c) into a two-coordinate reference frame known as the  $\alpha\beta$  frame. This transformation simplifies the subsequent analysis and control of the three-phase system. The  $\alpha\beta 0$  axis are calculated by using equations (1) and (2).

$$\begin{bmatrix} V_0 \\ V_\alpha \\ V_\beta \end{bmatrix} = \sqrt{\frac{2}{3}} \begin{bmatrix} \frac{1}{\sqrt{2}} & \frac{1}{\sqrt{2}} & \frac{1}{\sqrt{2}} \\ 1 & -\frac{1}{2} & -\frac{1}{2} \\ 0 & \frac{\sqrt{3}}{2} & -\frac{\sqrt{3}}{2} \end{bmatrix} \begin{bmatrix} V_a \\ V_b \\ V_c \end{bmatrix} \quad - (1)$$

$$\begin{bmatrix} I_0 \\ I_\alpha \\ I_\beta \end{bmatrix} = \sqrt{\frac{2}{3}} \begin{bmatrix} \frac{1}{\sqrt{2}} & \frac{1}{\sqrt{2}} & \frac{1}{\sqrt{2}} \\ 1 & -\frac{1}{2} & -\frac{1}{2} \\ 0 & \frac{\sqrt{3}}{2} & -\frac{\sqrt{3}}{2} \end{bmatrix} \begin{bmatrix} I_a \\ I_b \\ I_c \end{bmatrix} \quad - (2)$$

Load side instantaneous active and reactive power components are calculated by using  $\alpha\beta 0$  frame as given in equation (3)

$$\begin{bmatrix} p_0 \\ p \\ q \end{bmatrix} = \sqrt{\frac{2}{3}} \begin{bmatrix} V_0 & 0 & 0 \\ 0 & V_\alpha & V_\beta \\ 0 & -V_\beta & V_\alpha \end{bmatrix} \begin{bmatrix} I_0 \\ I_\alpha \\ I_\beta \end{bmatrix} \quad - (3)$$

Under balanced and undistorted conditions, the  $\alpha$  coordinate corresponds to the 'a' phase quantity, while the  $\beta$  coordinate is derived by combining the 'a', 'b', and 'c' phases. The 0 coordinate represents the zero-sequence component, which should ideally be zero in a balanced system

$$\begin{bmatrix} p \\ q \end{bmatrix} = \sqrt{\frac{2}{3}} \begin{bmatrix} V_\alpha & -V_\beta \\ V_\beta & V_\alpha \end{bmatrix} \begin{bmatrix} I_\alpha \\ I_\beta \end{bmatrix} \quad - (4)$$

The instantaneous active and reactive power components consist of both DC and AC components. By filtering out the low-frequency components, the high-pass filter helps to isolate the dynamic variations in the power signal, which are then utilized to calculate the reference current.

$$\begin{bmatrix} I_{\alpha}^{ref} \\ I_{\beta}^{ref} \end{bmatrix} = \frac{1}{V_{\alpha}^2 + V_{\beta}^2} \begin{bmatrix} V_{\alpha} & -V_{\beta} \\ V_{\beta} & V_{\alpha} \end{bmatrix} \begin{bmatrix} -p + p_{loss} \\ -q \end{bmatrix} \quad - (5)$$

Using the reverse Clarke's transformation, we get

$$\begin{bmatrix} I_a \\ I_b \\ I_c \end{bmatrix} = \sqrt{\frac{2}{3}} \begin{bmatrix} 1 & 0 \\ -\frac{1}{2} & \frac{\sqrt{3}}{2} \\ -\frac{1}{2} & -\frac{\sqrt{3}}{2} \end{bmatrix} \begin{bmatrix} I_{\alpha} \\ I_{\beta} \end{bmatrix} \quad - (6)$$

This is the reference current ( $I_a, I_b, I_c$ ) to be drawn by the SAPF inverter for harmonic currents and reactive power compensation drawn by the non-linear load. [9]

### 2.2.6 Hysteresis Band Current Control

The Hysteresis Band Current Control Logic is employed in shunt active power filters to generate gate signals for the inverter. This control strategy ensures that the inverter current closely follows the reference currents within a predefined hysteresis band. By maintaining the current within this band, the non-linear load is effectively compensated, and power quality is improved.

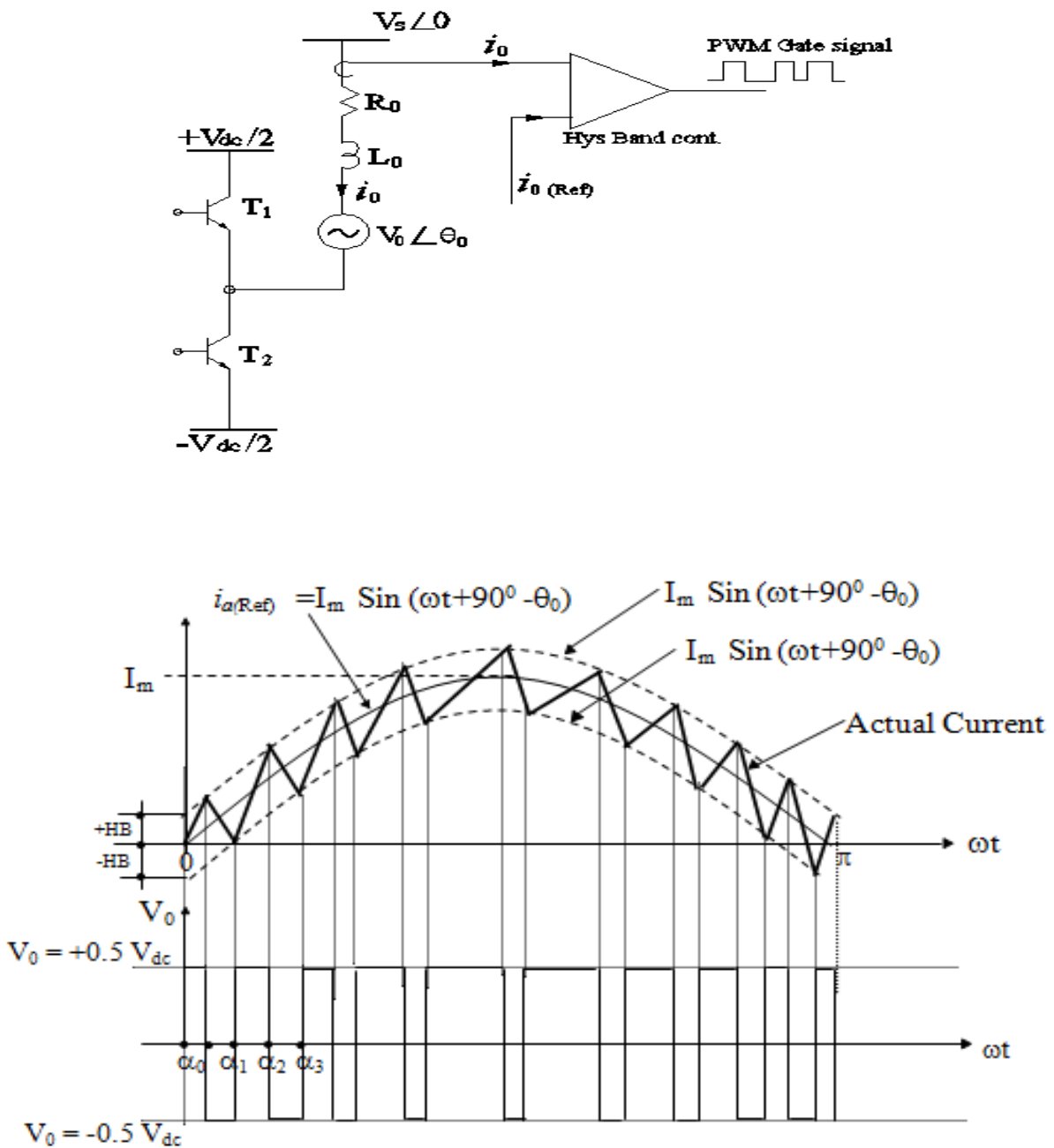

Figure 2. 8 Control logic of Hysteresis Band Current Control technique

The controller in the system compares the instantaneous injected current ( $I_o$ ) from the inverter with the generated reference current ( $I_{ref}$ ). Based on this comparison, the controller creates and adjusts the hysteresis band of the current, defining the permissible range within which the actual current should fluctuate.

- When the T1 is turn ON, the current ( $i_o$ ) builds up through inductive circuit ( $L_o R_o$ ), when it hits the upper band, T1 turns Off and T2 turns On.
- When the T2 is turn ON, the current ( $i_o$ ) decays through inductive circuit ( $L_o R_o$ ), when it hits the lower band, T2 turns Off and T1 turns On and so on and accordingly PWM gate signal is generated for phase-a and the inverter currents tracks the Ref current.
- Similarly, the gate signal for phase b and phase c is generated.

The use of a hysteresis current controller in the control of a grid-tied VSI provides several advantages. Firstly, the hysteresis current controller ensures that the output current of the VSI follows the reference current closely, minimizing the impact of grid disturbances and ensuring the stability of the grid. Secondly, the hysteresis current controller provides fast response times, allowing the system to respond quickly to changes in the output current. Finally, the hysteresis current controller is a simple and robust method of control, requiring minimal computational resources and offering high reliability [10]

# CHAPTER THREE: METHODOLOGY

## 3.1 Proposed Scheme

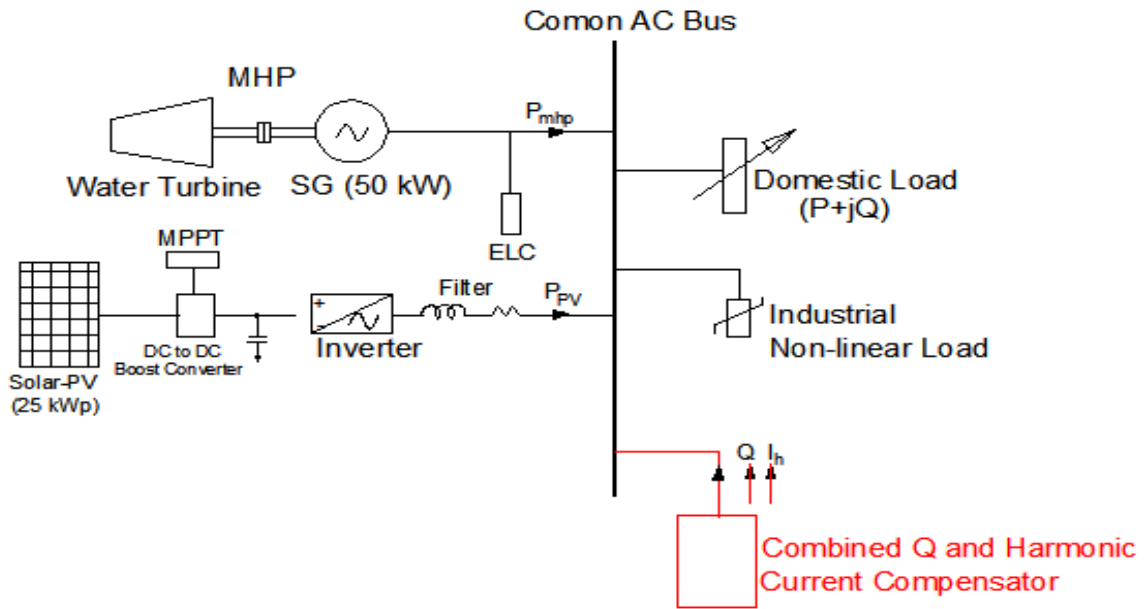

Figure 3. 1 Proposed scheme

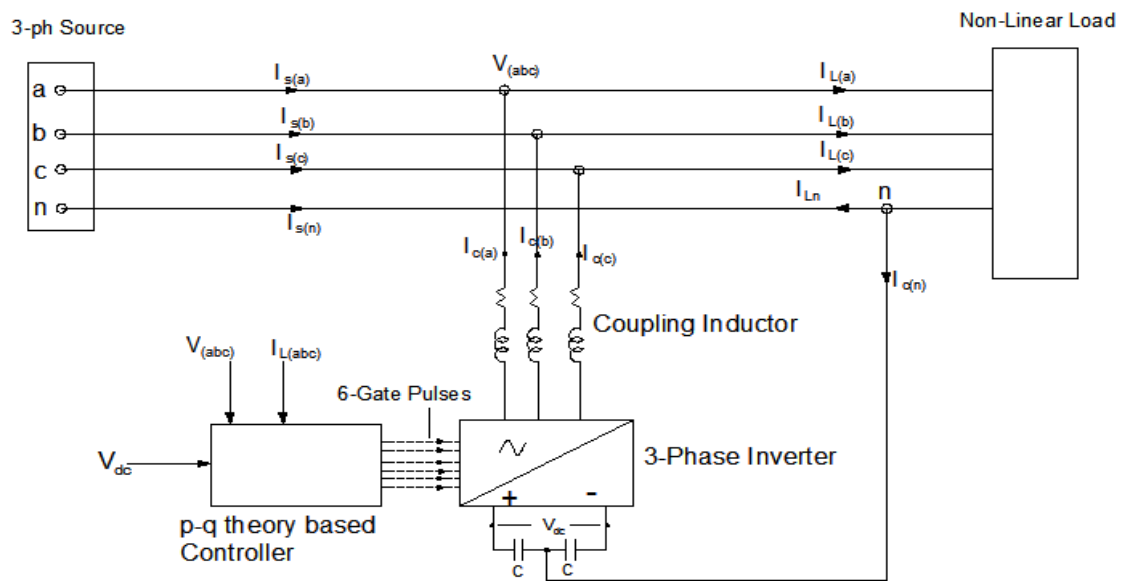

Figure 3. 2 Schematic diagram shunt active power filter based on instantaneous P-Q theory

The inverter employed in the SAPF is regulated to inject current into the AC bus, compensating for the harmonic current and reactive power consumed by the non-linear load. The PQ algorithm allows for the selection of the power to be compensated, and from this, the reference current is derived. The reference current, obtained from the previous steps, is input to the closed-loop hysteresis band controller, which serves as a current controller. The controller compares the reference current with the actual current provided by the filter and generates the appropriate gate signal for the inverter circuit based on this comparison. This gate signal controls the switching of the semiconductor devices in the inverter, enabling it to generate the desired current to compensate for the harmonics and reactive power of the non-linear load. By continuously monitoring the current and adjusting the gate signals, the controller ensures that the inverter provides the necessary compensation to keep the current within the desired range, effectively mitigating the effects of harmonics and reactive power caused by the non-linear load. Two dc link capacitors act as the energy storing device and, gets charged and discharged during one cycle of load current.

## **3.2 Overview**

The overall methodologies of the project are mentioned below:

Step-1: Study of literature and basic theories related to project topics

Step-2: Problem identification

Step-3: Non-linear load simulation modeling.

Step-4: Grid connected PV- system Simulation modeling

Step-5: Micro-hydro plant Simulation modeling

Step 6: Electronic load Controller Simulation modeling

Step 7: Run the PV and Micro-Hydro in parallel with local household and industrial load

Step-8: Calculation of  $I_{ref}$  using instantaneous PQ theory

Step-9: Use of hysteresis band control logic

Step-10: Development of a simulation model of a grid connected PV-system with shunt active power filter.

### 3.3 Simulation Tool

For modeling of our PV system and simulation is done in MATLAB/SIMULINK (2021a). MATLAB is a proprietary programming language and computational environment that is widely used for engineering and scientific applications. It is a high-level language that has evolved over time to become a powerful and versatile tool. MATLAB is particularly well-suited for specialized engineering and scientific tasks, offering a range of features. In recent years, MATLAB has made significant advancements in its graphics capabilities, particularly in the realm of object-oriented graphics. This has allowed users to create visually appealing and interactive Graphical User Interfaces (GUIs) for their applications. [11].

On top of MATLAB, Simulink is constructed. Simulink provides an interactive and user-friendly environment for modeling and simulating dynamic systems. It offers the convenience of graphical block diagram modeling, real-time visualization of simulation results, and the ability to customize and expand the simulation environment to meet specific application needs.. [12]. The seamless integration between Simulink and MATLAB allows for efficient model development, simulation, and analysis, making it an ideal tool for engineers and scientists working on various engineering and scientific applications.

### 3.4 Development of nonlinear load

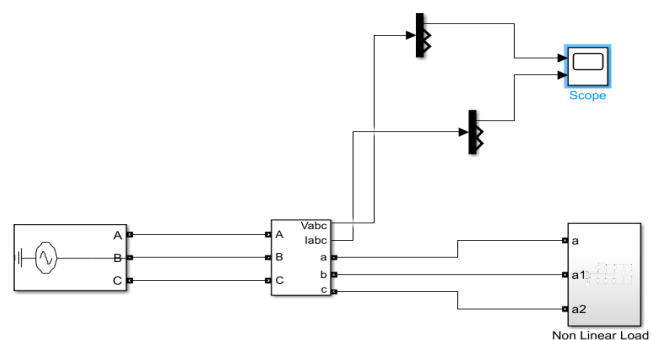

Figure 3.3 Non-Linear Load System

This model is inside the subsystem Non-Linear load of figure 4.1. In this system we have use three phase source, voltage measurement block and a subsystem non-linear load. The subsystem is explained below.

### 3.5 Inside Nonlinear load subsystem

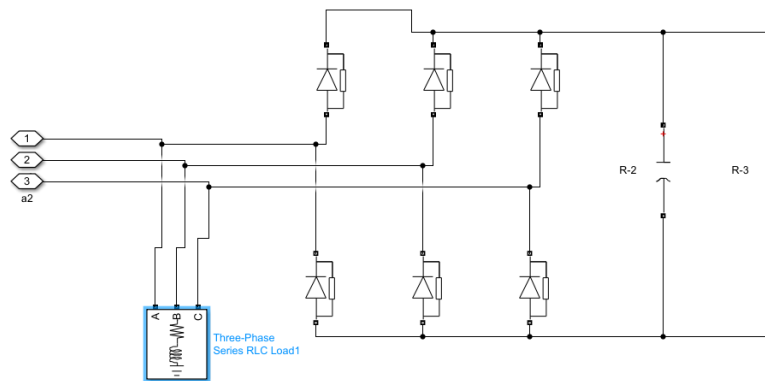

Figure 3.4 Non-Linear Load Subsystem

This is the subsystem of non-linear load. This system contains a rectifier circuit which acts as a non-linear load by consuming non-sinusoidal current. Here we have used diodes as our circuit elements, resistor of 10 ohms and capacitance value of 5000 microfarad.

### 3.6 Development of Grid Connected PV with MPPT

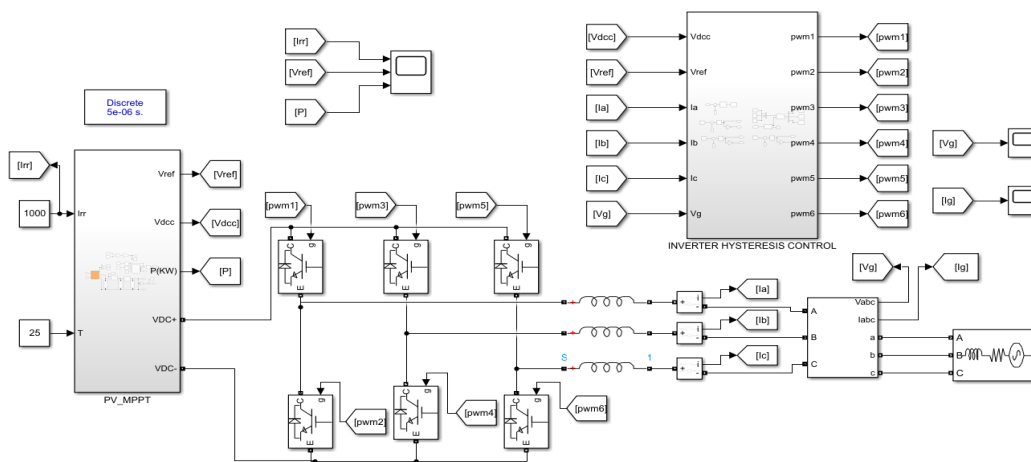

Figure 3.5 PV with Perturbation and Observation based MPPT Algorithm

This circuit is the demonstration of PV with MPPT. This circuit contains PV panel with boost converter which is to be fed to inverter circuit.

### 3.7 PV MPPT subsystem

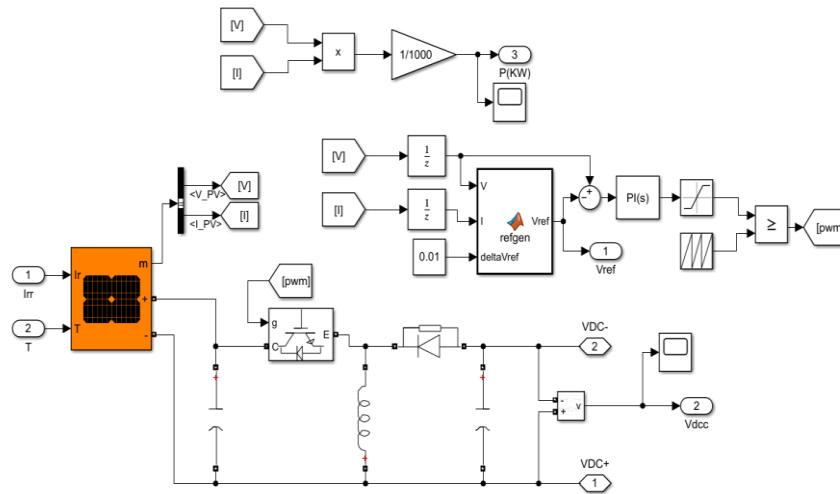

Figure 3.6 MPPT Subsystem

This subsystem helps to track the MPP of the PV. The MPPT is performed by the Perturbation and Observation algorithm. The PV system measures the voltage and current from the PV source, which are then input to the MPPT function block. The MPPT function block tracks the optimal operating point of the PV system and generates the appropriate reference voltage ( $V_{ref}$ ). Once  $V_{ref}$  is determined, it is compared with the actual voltage ( $V$ ) and a signal is generated, The PWM signal is utilized to control the gate switch of the Buck-Boost Converter. The converter ensures that the DC link capacitor maintains the voltage at  $V_{ref}$ , thus enabling the maximum power to be tracked and extracted from the PV source. By regulating the voltage through the converter, the system can operate at the point where maximum power is achieved, maximizing the efficiency and output of the PV system.

### 3.8 PV Inverter Hysteresis Control subsystem

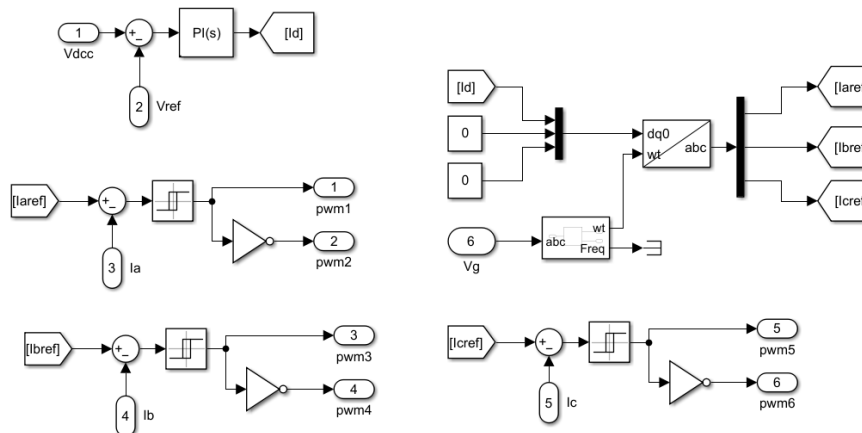

Figure 3.7 Inverter hysteresis control logic

The direct relationship between the voltage across the DC link capacitor ( $V_{dcc}$ ) and the active power flow in the system can be observed. The voltage across the capacitor increases proportionally with an increase in active power, and conversely, it decreases when the active power decreases. This interdependency enables efficient control and regulation of power flow within the system, ensuring optimal performance and stability. The voltage across the capacitor, along with the reference voltage ( $V_{ref}$ ), undergoes a comparison process, and the resulting error is then fed into a PI controller. The output corresponds to the direct current ( $I_d$ ) within the dq0 frame. The grid voltage ( $V_g$ ) undergoes processing through a Phase Lock Loop block to extract the angular frequency ( $\omega t$ ) of the grid. The extracted angular frequency is subsequently employed to convert the  $I_d$  value from the dq0 frame to the abc frame. The current in the abc frame acts as a reference for the current generated by the inverter. By comparing the reference current ( $I_{ref}$ ) with the current in the abc frame ( $I_{abc}$ ), the system calculates and determines the error between the two. The error is subsequently employed to generate PWM gate pulses, which regulate the switching of the inverter. This control mechanism ensures that the actual current aligns with the desired reference current. The closed-loop control mechanism plays a crucial role in achieving accurate and precise current regulation within the system. It ensures that the system operates optimally, maintaining the desired current levels and enabling precise control.

### 3.9 Development of Micro Hydro Plant

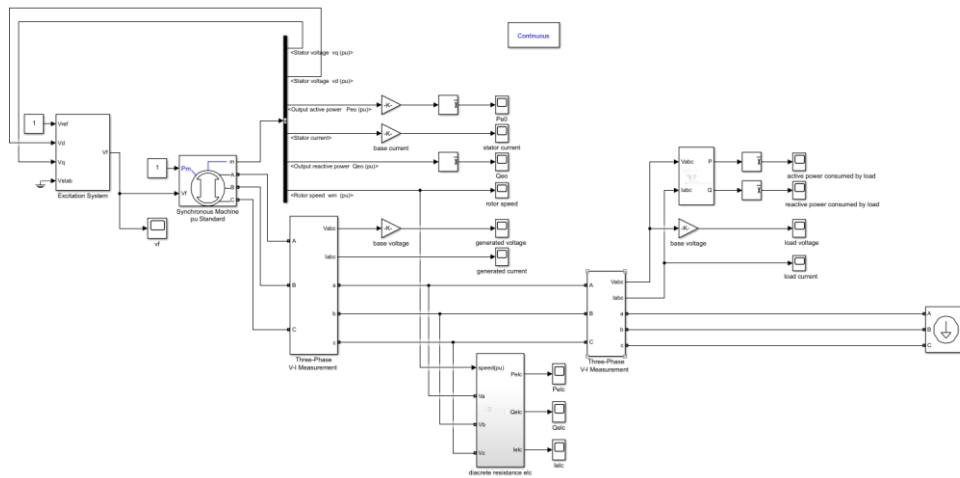

Figure 3. 8 Simulation model of micro-hydro plant

This is the Simulink model of Micro Hydro Plant with Synchronous generator and Electronic Load Controller.

### 3.10 Development of Discrete Resistance ELC

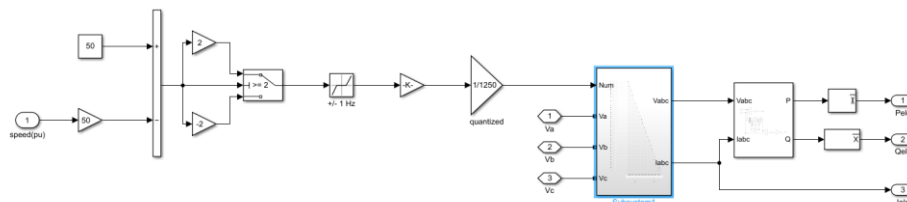

Figure 3. 9 Simulation model of Electronic Load Controller

This is the Simulink model of Electronic Load Controller based on discrete resistance mechanism. By activating the dump load in response to speed deviations, the ELC ensures that the rotor speed remains close to the desired value, or 1pu (per unit). This control mechanism helps stabilize and maintain the operation of the system within the desired speed range. The Simulink model provides a visual representation of the ELC control system, allowing for simulation and analysis of its performance under different conditions.

### 3.11 Development of Shunt Active Power Filter model

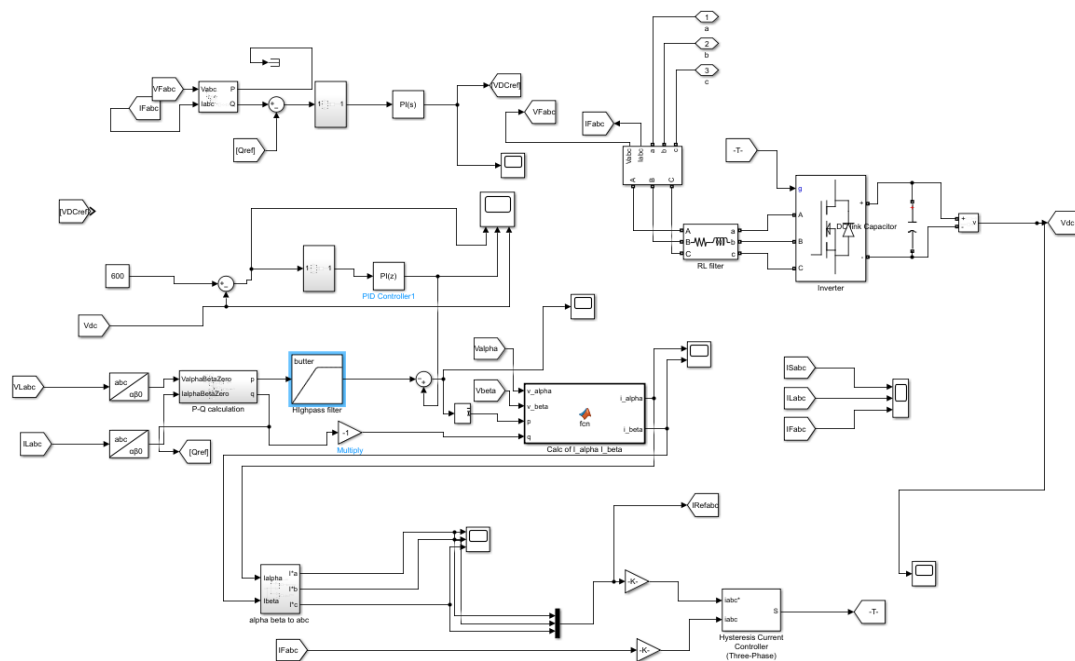

Figure 3.10 Shunt Active Power Filter model

This is the model of our shunt active power filter which consists of the following components and operations. The SAPF generates the three-phase current output,  $I_{fabc}$ , through the inverter. The DC link capacitor provides the DC source for the inverter operation. The voltage and current measurements,  $V_{abc}$  and  $I_{abc}$ , are taken from the PV-Micro grid and fed into the system. These measurements are then transformed from the abc (phase) coordinates to the  $\alpha\beta$  coordinates using The PQ theory is applied to calculate the instantaneous active and reactive power based on the transformed voltage and current signals. This information is used for further control and calculation purposes. The DC link voltage is compared to the reference voltage, and the internal losses in the compensator are determined. This information helps in optimizing the overall performance and efficiency of the system. The instantaneous power is passed through a high pass filter to extract the power losses (Ploss), as well as the voltage components  $V_\alpha$  and  $V_\beta$ . These values are utilized to calculate the reference current in the  $\alpha\beta$  frame. The inverse Clarke transformation is applied to convert the reference current from the  $\alpha\beta$  frame back to the abc frame. The inverter generates the necessary current to compensate for the harmonics and reactive power caused by the nonlinear load. This helps in improving the overall power quality and reducing disturbances in the system.

### 3.12 Overall model

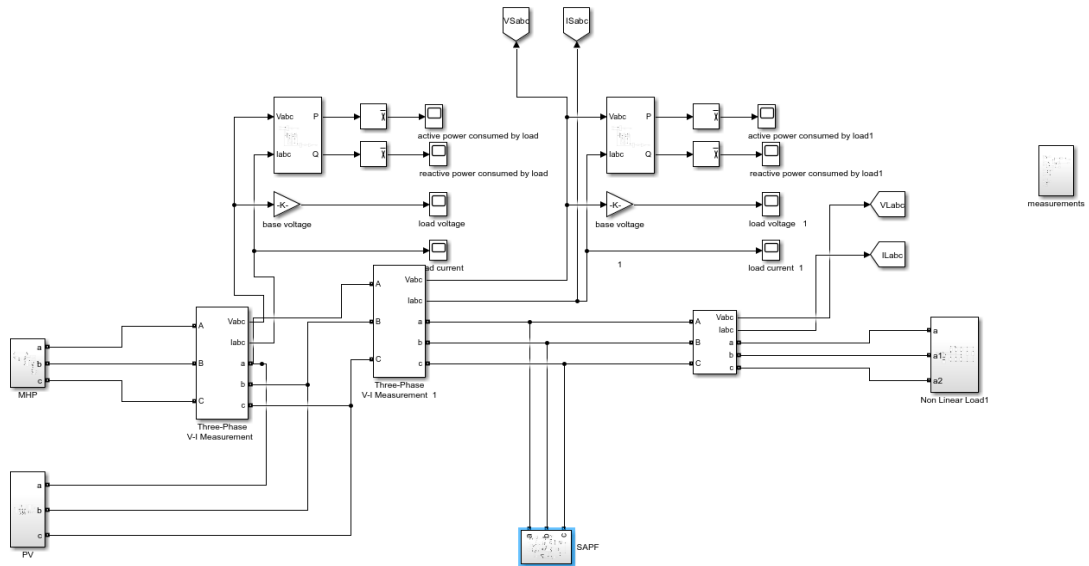

Figure 3.11 Overall model

The complete model integrates a micro hydro power plant (MHP), a photovoltaic (PV) plant, a shunt active power filter (SAPF), and a nonlinear load. The SAPF is interconnected with the MHP and PV systems in parallel to address the impact of the nonlinear load. By utilizing the model, it becomes possible to monitor and assess the behavior of load current, source current, and compensator current in two different scenarios: with the presence of the SAPF and in its absence. This allows for a comprehensive analysis of the SAPF's effectiveness in improving the system's performance and mitigating the impact of the nonlinear load.

# CHAPTER FOUR: RESULT AND DISCUSSION

## 4.1 Nonlinear Waveform Current Output

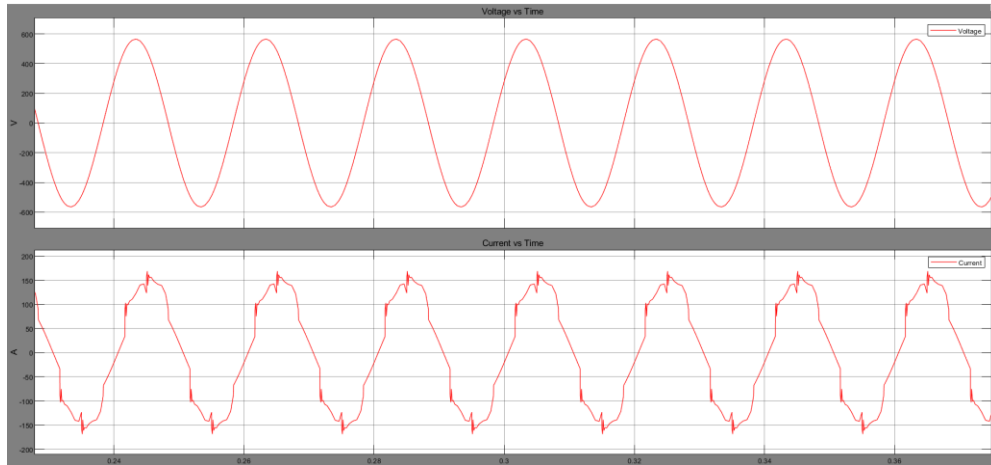

Figure 4. 1 Voltage and Current Waveform of Non-Linear Load

We can observe the distortion in the waveform of non- linear load in comparison to a sinusoidal input.

## 4.2 PV Array Characteristic Curve

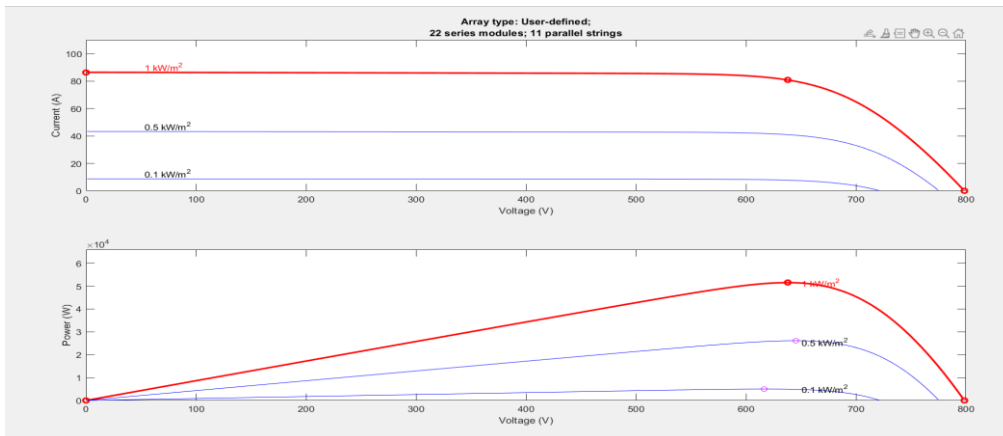

Figure 4. 2 I-V and P-V characteristics of PV system at different irradiance level

This is the characteristic curve of the PV module that we selected. From the above curve we can conclude that the maximum power point lies when Voltage is 638V at 1000 Irradiance.

### 4.3 PV System Output Waveforms model

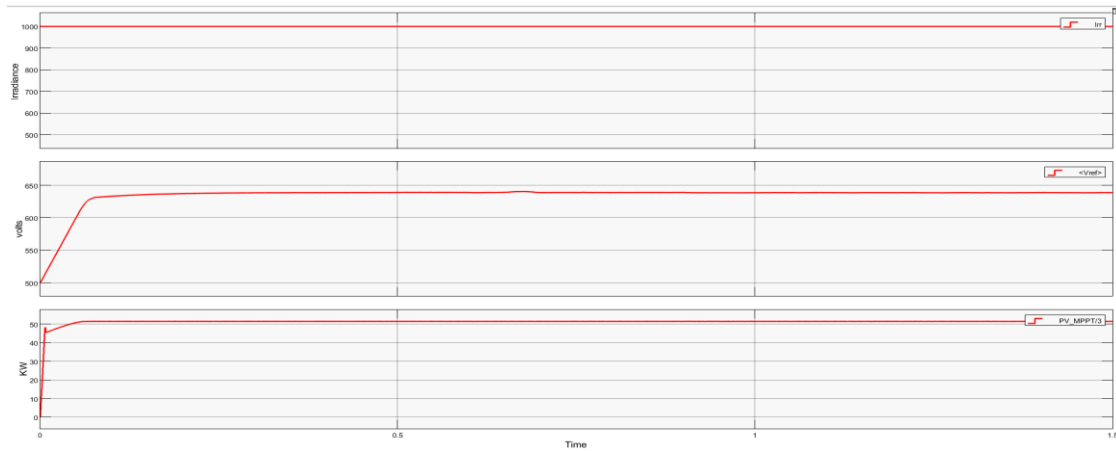

Figure 4. 3 PV system output waveforms

The waveform shows the output of the PV system module. The waveform is between irradiance and time, voltage and time, and power and time.

### 4.4 Output waveforms of MHP model

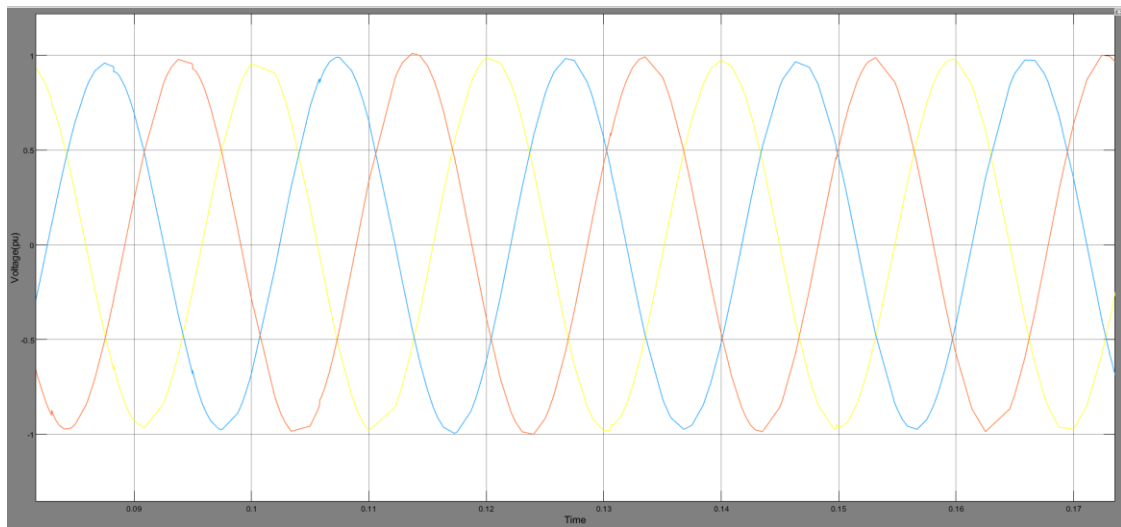

Figure 4. 4 Output voltage waveform of MHP

According to our model the MHP was successfully able to generate 1pu voltage at varying load conditions.

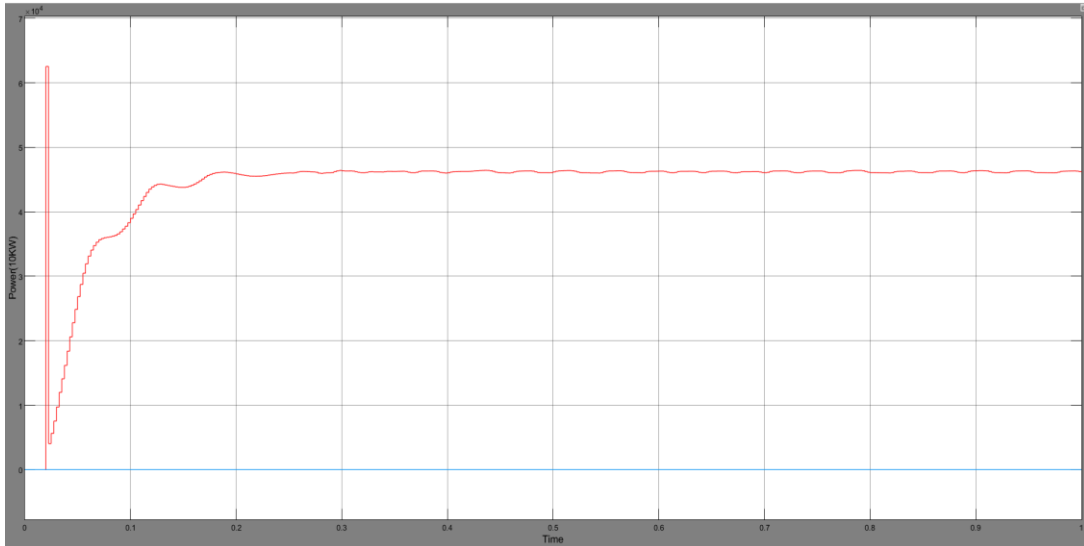

Figure 4. 5 Output power waveform of MHP

The power generated by the MHP is observed to be approximately 50kw.

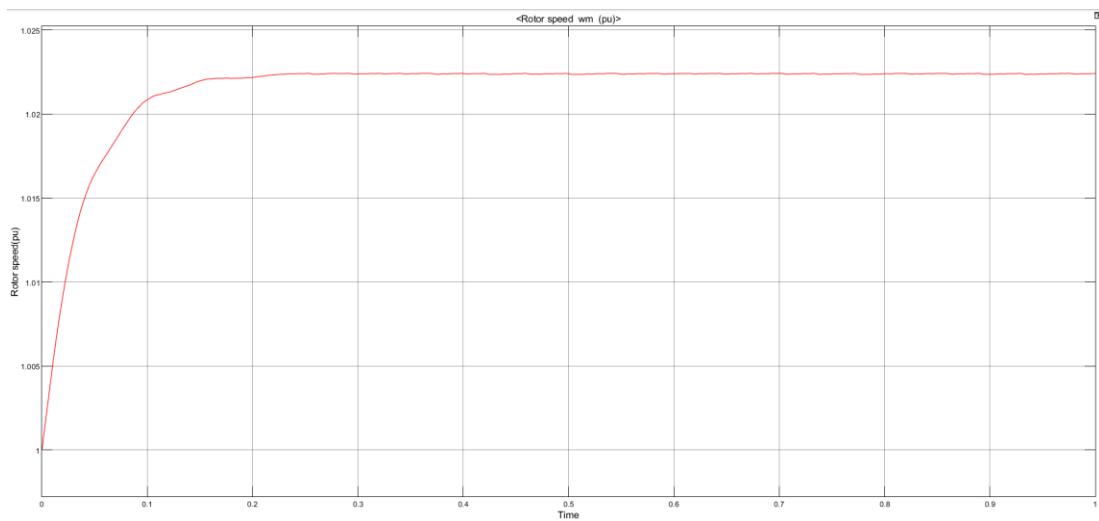

Figure 4. 6 Output waveform of rotor speed of MHP

Here, we can observe that the fluctuation in load doesn't affect the rotor speed due to the excess power being dumped in the ELC. In this way the speed control of the MHP was preformed successfully.

## 4.5 DC link Capacitor Voltage

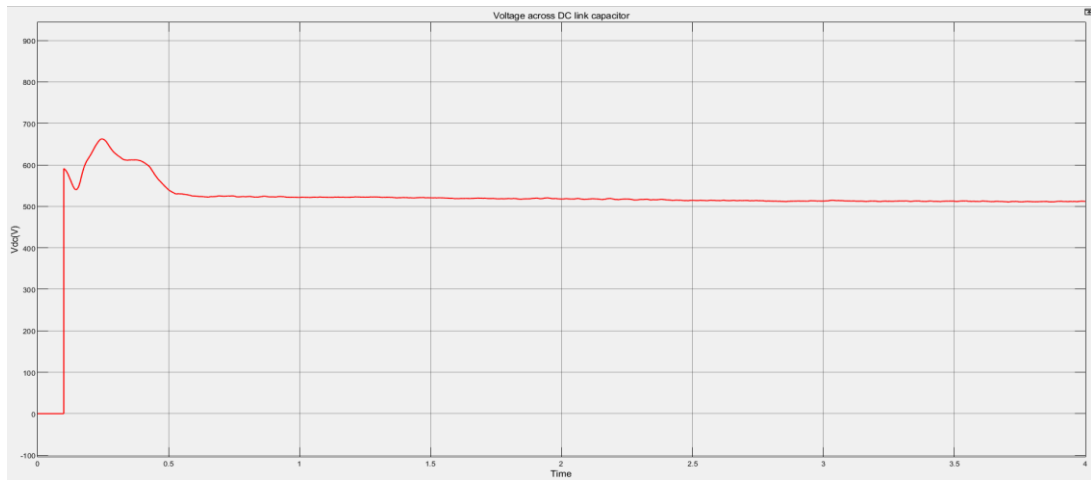

Figure 4. 7 DC link capacitor voltage

The DC link capacitor voltage with respect to time is plotted in above figure. The PI controller is successfully tuned to get a constant DC voltage.

## 4.6 Output waveforms of Overall model Without SAPF

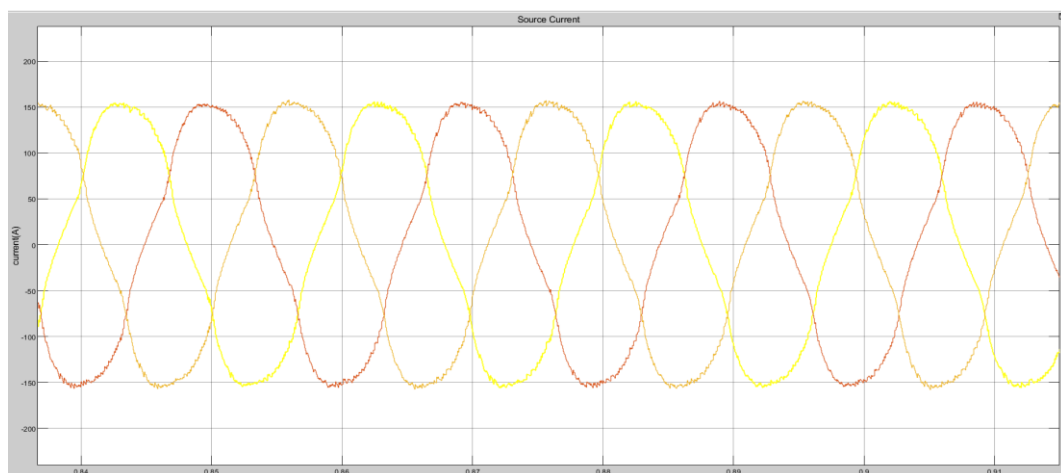

Figure 4. 8 Output waveforms of Overall model Without SAPF

As we can see from the above waveform, the source current supplied by the MHP and PV plant is nonlinear. This can hamper the windings of the generator, as well as the inverter of the PV plant. It can also cause heating to transformers and switchgears.

## 4.7 Output waveforms of Overall model with SAPF

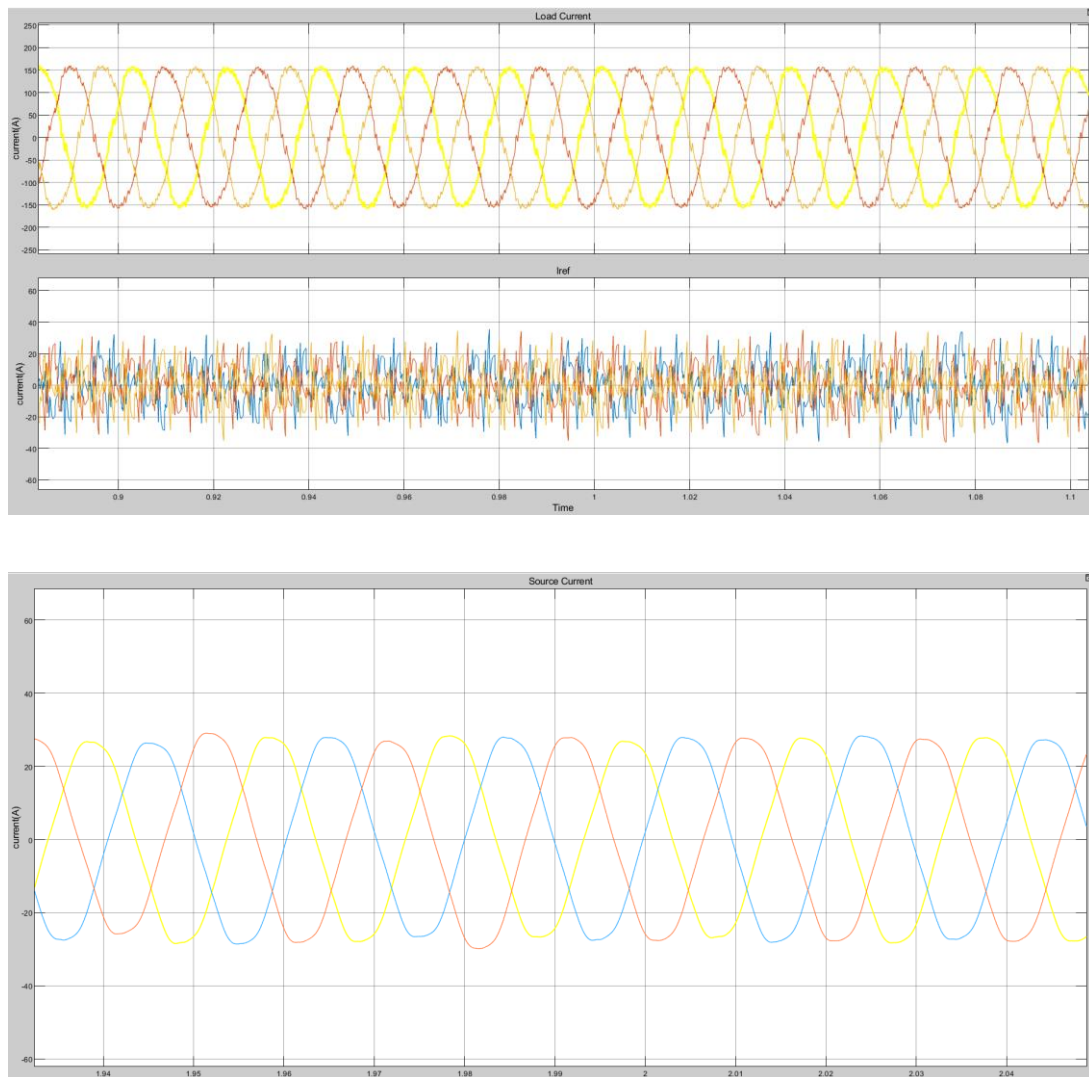

Figure 4. 9 Output waveforms of Overall model with SAPF

By connecting the SAPF we observed the load current, current from SAPF and source current. The result is shown respectively in the above figure. The source provides exclusively sinusoidal current, while the inverter of the SAPF supplies the nonlinear component of the load current.

## 4.8 THD Analysis of Source Current Without SAPF

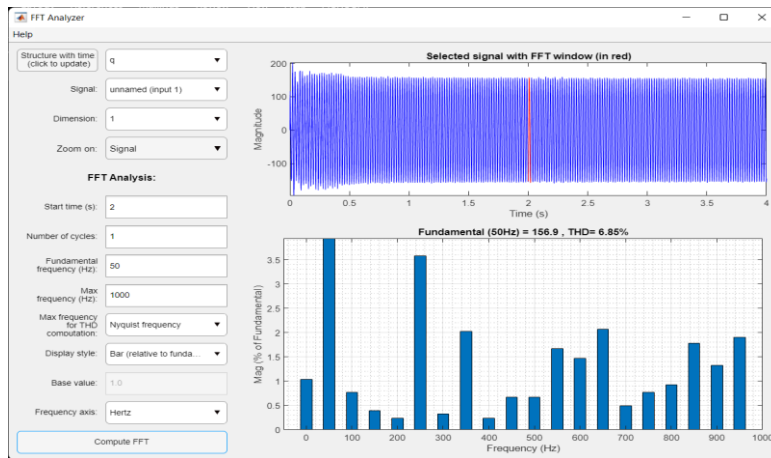

Figure 4. 10 THD Analysis of Source Current Without SAPF

As depicted in the preceding figure, the Total Harmonic Distortion (THD) of the source current, in the absence of the SAPF, measures approximately 7%. By increasing the nonlinear property of the load, it can be varied and can be more in practical load.

## 4.9 THD Analysis of Source Current With SAPF

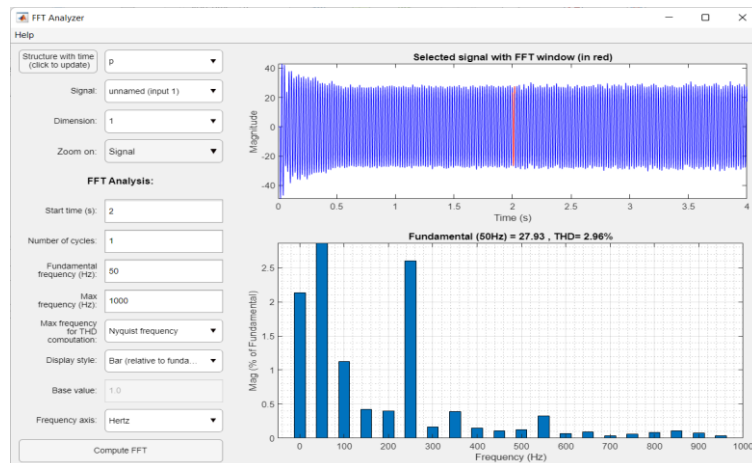

Figure 4. 11 THD Analysis of Source Current With SAPF

The utilization of SAPF results in a reduction of the Total Harmonic Distortion (THD) of the source current, bringing it down to approximately 2.96%. When load with higher nonlinear property is used the SAPF also works properly reducing THD accordingly.

## **CHAPTER FIVE**

### **CONCLUSION**

The study focuses on addressing the challenges associated with reactive power and harmonic current in a PV micro hydro grid using a SAPF and hysteresis band current control logic. In order to assess the reliability and adaptability of the proposed method, two different types of loads are taken into consideration. By considering multiple load scenarios, the performance and effectiveness of the system can be evaluated across various operating conditions. This approach provides a comprehensive analysis of the proposed method's applicability and robustness in handling different load characteristics.

The total harmonic distortion (THD) of the source current is observed to decrease from approximately 7% to 2.96% when the SAPF is employed. The Total Harmonic Distortion (THD) of the source current is significantly reduced, resulting in a cleaner and more stable power supply.

These findings highlight the significant reduction in harmonic content achieved by the shunt active power filter. The simulation validates the capability of the SAPF to effectively compensate for harmonic distortions, thereby improving the overall power quality of the system.

## References

- [1] A. Shah, "Shunt active power filter for power quality improvement in distribution system".
- [2] J. L. Alfonso, M. Aredes, J. S. Martins and E. Watanabe, "Shunnt Active Filter for Quality Improvement," p. 691, 2000.
- [3] S. Bagi, s. bagwadi and f. Kudchi, "Power Quality Improvement Using a Shunt Active Power Filter," India, 2020.
- [4] Y. T. Tan and D. S. Kirschen, "A Model of PV Generation: suitable for stability analysis," 2004.
- [5] Intenational, Mirus, "Power Quality blog".
- [6] M. Rashid, "Power Electronics Handbook : Devices , Circuit and Application," Butterworth Heinemann , 2011.
- [7] A. Y. A. A. Y. A. Ahmed M Atallah, "Implementation of perturb and observe MPPT of PV system withdirect control method using buck and buck boost converters," pp. 31-44, 2014.
- [8] H. Akagi, Y. Kanazawa and A. Nabae, "Generalized Theory of Instantaneous Reactive Power and its application," University of Nakoga, 1983.
- [9] T. Sapkota, S. Poudel, R. Subedi and S. Gyawali, "Three Phase Four Wire Shunt Active Filter," Lalitpur, 2014.
- [10] M. B. H. Ahmed, "Adaptive observer based grid synchronization and sequence extraction techniques for renewable energy systems," 2021.
- [11] The Mathworks Inc., "MATLAB : High performance Numeric computation and visualization software," 1993.
- [12] Thw Mathworks Inc, "SIMULINK: The Dynamic System Simulation software User's Guide," 1993.
- [13] A. Kulkalrni, "grid connected Single phase pv inverter harmonics".
- [14] C. Singh and A. Haddad, "A Review of active filter for power quality improvement".
- [15] F. kuhaid, "Harmonic in single phase pv inverter".
- [16] H. M. ., M. E. A. K.Boudaraia, "Modeling and control of three phases grid connected photovoltaic system," *International renewable and sustainable energy conference*, pp. 812-816, 2016.

# APPENDIX

## APPENDIX A: Perturbation and Observation Algorithm

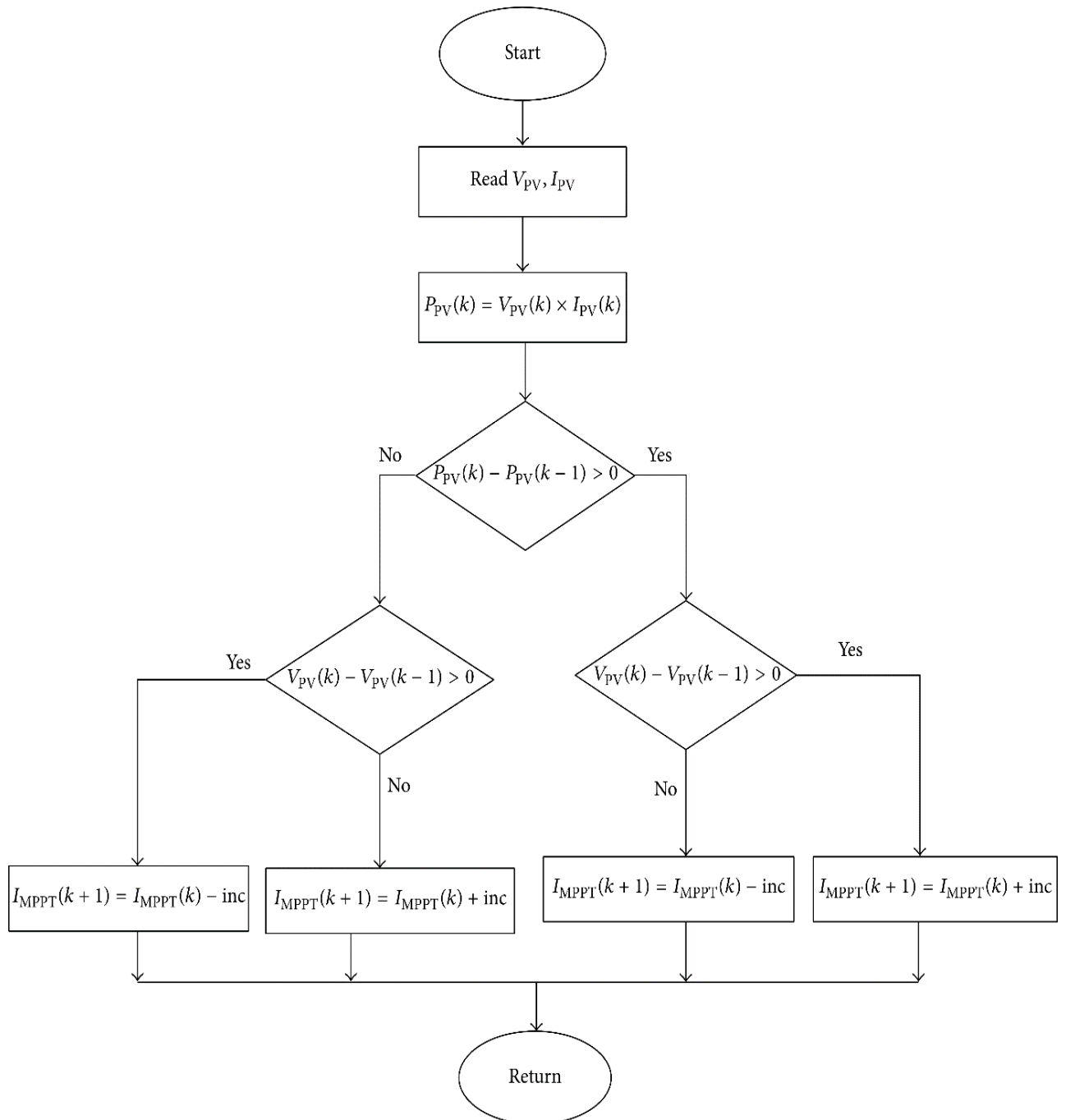

Figure 4. 1 Perturbation and Observation Flowchart

## APPENDIX B: MATLAB function code for MPPT

```
function Vref = refgen(V,I,deltaVref)
Vrefmax = 800;
Vrefmin = 0;
Vrefinit = 500;

persistent Vold Vrefold Pold;

if isempty (Vold)
    Vold = 0;
    Pold = 0;
    Vrefold = Vrefinit;
end

P = V*I;
dV = V - Vold;
dP = P - Pold;

if dP ~= 0
    if dP < 0
        if dV < 0
            Vref = Vrefold + deltaVref;
        else
            Vref = Vrefold - deltaVref;
        end
    else
        if dV < 0
            Vref = Vrefold - deltaVref;
        else
            Vref = Vrefold + deltaVref;
        end
    end
else
    Vref = Vrefold;
end
if Vref >= Vrefmax || Vref < Vrefmin
    Vref = Vrefold;
end

Vrefold = Vref;
Vold = V;
Pold = P;
end
```



# Last aba na garne

---

## ORIGINALITY REPORT

---

17%

SIMILARITY INDEX

---

### PRIMARY SOURCES

---

1	<a href="http://www.researchgate.net">www.researchgate.net</a> Internet	98 words — 2%
2	<a href="#">Lecture Notes in Electrical Engineering, 2015.</a> Crossref	91 words — 2%
3	<a href="http://1library.net">1library.net</a> Internet	66 words — 1%
4	<a href="http://manualzz.com">manualzz.com</a> Internet	51 words — 1%
5	<a href="http://etd.auburn.edu">etd.auburn.edu</a> Internet	26 words — < 1%
6	<a href="http://ethesis.nitrkl.ac.in">ethesis.nitrkl.ac.in</a> Internet	26 words — < 1%
7	<a href="#">Devi Prasad Acharya, Subhashree Choudhury, Niranjana Nayak. "Photovoltaic Cell Based Shunt Active Filter and Power Quality Improvement Using Hybrid Optimization Technique", 2019 International Conference on Intelligent Computing and Remote Sensing (ICICRS), 2019</a> Crossref	25 words — < 1%
8	<a href="http://doi.org">doi.org</a> Internet	25 words — < 1%

- 
- 9 noexperiencenecessarybook.com 25 words — < 1%  
Internet
- 
- 10 Akagi. "The Instantaneous Power Theory", 20 words — < 1%  
Instantaneous Power Theory and Applications to  
Power Conditioning, 02/02/2007  
Crossref
- 
- 11 dspace.dtu.ac.in:8080 19 words — < 1%  
Internet
- 
- 12 Shreya Parmar, Nikunj Prajapati, Anand 17 words — < 1%  
Panchbhai. "Optimum Solution for Power  
Conditioning in DC Motor Drives Using Shunt Active Power  
Filter", 2018 4th International Conference on Electrical Energy  
Systems (ICEES), 2018  
Crossref
- 
- 13 www.ijser.org 17 words — < 1%  
Internet
- 
- 14 Alsharif, Bandar S.. "The Influence of Loading and 16 words — < 1%  
Voltage Supply Conditions LV Feeder on  
Harmonic Emission", King Fahd University of Petroleum and  
Minerals (Saudi Arabia), 2023  
ProQuest
- 
- 15 S.J. Chiang, J.M. Chang. "Parallel operation of 15 words — < 1%  
shunt active power filters with capacity limitation  
control", IEEE Transactions on Aerospace and Electronic  
Systems, 2001  
Crossref
- 
- 16 dspace.cvut.cz 15 words — < 1%  
Internet

---

17 Luis Morán, Juan Dixon, Miguel Torres. "Active Power Filters", Elsevier BV, 2018 14 words — < 1%  
Crossref

---

18 Pratap Sekhar Puhan, Pravat Kumar Ray, Gayadhar Panda. "Development of Real Time Implementation of 5/5 Rule based Fuzzy Logic Controller Shunt Active Power Filter for Power Quality Improvement", International Journal of Emerging Electric Power Systems, 2016 14 words — < 1%  
Crossref

---

19 Dai, Hang. "Investigation of Current Source Inverter Using Wide Bandgap Devices for Integrated Motor Drive Applications", The University of Wisconsin - Madison, 2023 12 words — < 1%  
ProQuest

---

20 Virmani, Rahul, Purna Gaur, Himanshu Santosi, A.P. Mittal, and Bhim Singh. "Performance comparison of UPQC and Active Power Filters for a non-linear load", 2010 Joint International Conference on Power Electronics Drives and Energy Systems & 2010 Power India, 2010. 12 words — < 1%  
Crossref

---

21 [garuda.ristekdikti.go.id](http://garuda.ristekdikti.go.id) 12 words — < 1%  
Internet

---

22 Jiansong Zhang, Xu Yang, Wenjie Chen, Hongwei Zhou, Jie Luo. "A Multifrequency Small-Signal Model for the MLCL-Filtered Grid-Connected Inverter Considering the FCE of Nonlinear Inductors", IEEE Transactions on Industrial Electronics, 2023 11 words — < 1%  
Crossref

---

23 Kakoli Bhattacharjee. "Harmonic mitigation by SRF theory based active power filter using 11 words — < 1%

adaptive hysteresis control", 2014 POWER AND ENERGY SYSTEMS: TOWARDS SUSTAINABLE ENERGY, 2014

Crossref

---

24 mafiadoc.com 11 words — < 1%

Internet

---

25 oaktrust.library.tamu.edu 11 words — < 1%

Internet

---

26 "Advances in Smart Grid and Renewable Energy", Springer Science and Business Media LLC, 2018 10 words — < 1%

Crossref

---

27 Abdusalam, M.. "New digital reference current generation for shunt active power filter under distorted voltage conditions", Electric Power Systems Research, 200905 10 words — < 1%

Crossref

---

28 Karthik D, , Sheik Barideen S, and Palanisamy K. "Power Quality improvement using 3-phase Unified Power Quality Conditioner with minimum VA rating", 2014 International Conference on Advances in Electrical Engineering (ICAEE), 2014. 10 words — < 1%

Crossref

---

29 M. Kadjoudj, M.E.H. Benbouzid, C. Ghennai, D. Diallo. "A Robust Hybrid Current Control for Permanent-Magnet Synchronous Motor Drive", IEEE Transactions on Energy Conversion, 2004 9 words — < 1%

Crossref

---

30 S.J. Chiang, K.T. Chang, C.Y. Yen. "Residential photovoltaic energy storage system", IEEE Transactions on Industrial Electronics, 1998 9 words — < 1%

Crossref

- 
- 31 [easyreport.in](http://easyreport.in)  
Internet 9 words — < 1%
- 
- 32 [etd.lib.metu.edu.tr](http://etd.lib.metu.edu.tr)  
Internet 9 words — < 1%
- 
- 33 [ijccts.org](http://ijccts.org)  
Internet 9 words — < 1%
- 
- 34 [www.mdpi.com](http://www.mdpi.com)  
Internet 9 words — < 1%
- 
- 35 Almeida, Raul Fernando Silva. "Desenvolvimento de um Filtro Ativo Paralelo Monofásico Compacto e Didático Utilizando MOSFETs", Universidade do Minho (Portugal), 2023  
ProQuest 8 words — < 1%
- 
- 36 Anastasis Charalambous, Lenos Hadjidemetriou, Marios Polycarpou. "A Sensorless Asymmetric and Harmonic Load Compensation Method by Photovoltaic Inverters Based on Event-triggered Impedance Estimation", IEEE Transactions on Industrial Electronics, 2022  
Crossref 8 words — < 1%
- 
- 37 Chen, Zhe. "Modeling, Analysis, and Control of Grid-Forming PV Sources for Use in Mixed-Source Microgrids and Other Distribution Power System Applications", The University of Wisconsin - Madison, 2023  
ProQuest 8 words — < 1%
- 
- 38 Matototo, Séraphin Kasemuana. "Assessing the Contribution of Harmonics at the Point of Common Coupling in Networks", University of Johannesburg (South Africa), 2023  
ProQuest 8 words — < 1%

- 
- 39 Srinivasarao Kamala, B. Dastagiri Reddy, Binita Sen, Sanjib K. Panda, Gehan Amaratunga. "Improvement of power quality and reliability in the distribution system of petrochemical plants using active power filters", 2018 IEEE International Conference on Industrial Technology (ICIT), 2018  
Crossref 8 words — < 1%
- 
- 40 TARIQ, Mohd and YUVARAJAN, S.. "Simulink based modeling, analysis and simulation of self excited induction generator for use in remote areas", İstanbul Üniversitesi, 2013.  
Publications 8 words — < 1%
- 
- 41 [core.ac.uk](http://core.ac.uk)  
Internet 8 words — < 1%
- 
- 42 [digitalcommons.fiu.edu](http://digitalcommons.fiu.edu)  
Internet 8 words — < 1%
- 
- 43 [dlibrary.univ-boumerdes.dz:8080](http://dlibrary.univ-boumerdes.dz:8080)  
Internet 8 words — < 1%
- 
- 44 [hdl.handle.net](http://hdl.handle.net)  
Internet 8 words — < 1%
- 
- 45 [scholarsmine.mst.edu](http://scholarsmine.mst.edu)  
Internet 8 words — < 1%
- 
- 46 [www.researchtrend.net](http://www.researchtrend.net)  
Internet 8 words — < 1%
- 
- 47 B.K. Bose. "An adaptive hysteresis-band current control technique of a voltage-fed PWM inverter for machine drive system", IEEE Transactions on Industrial Electronics, 1990  
Crossref 7 words — < 1%

---

48 H. Rudnick, J. Dixon, L. Moran. "Delivering clean and pure power", IEEE Power and Energy Magazine, 2003 7 words — < 1%  
Crossref

---

49 A. Nabae, T. Tanaka. "A new definition of instantaneous active-reactive current and power based on instantaneous space vectors on polar coordinates in three-phase circuits", IEEE Transactions on Power Delivery, 1996 6 words — < 1%  
Crossref

---

50 Green Energy and Technology, 2015. 6 words — < 1%  
Crossref

---

51 Puhan, Pratap Sekhar, Pravat Kumar Ray, and Gayadhar Panda. "A comparative analysis of shunt active power filter and hybrid active power filter with different control techniques applied for harmonic elimination in a single phase system", International Journal of Modelling Identification and Control, 2015. 6 words — < 1%  
Crossref

---

52 Xiaorui Sun. "A shunt active power filter with control method based on neural network", PowerCon 2000 2000 International Conference on Power System Technology Proceedings (Cat No 00EX409) ICPST-00, 2000 6 words — < 1%  
Crossref

---

EXCLUDE QUOTES  ON

EXCLUDE BIBLIOGRAPHY  ON

EXCLUDE SOURCES  OFF

EXCLUDE MATCHES  OFF