



**TRIBHUVAN UNIVERSITY
INSTITUTE OF ENGINEERING
PULCHOWK CAMPUS**

THESIS NO: M-349-MSREE-2018-2022

**Impact in Substation Power Transformer Due to Injection of Non-linear
Load**

by

Sujit Tiwari

A THESIS

**SUBMITTED TO THE DEPARTMENT OF MECHANICAL AND
AEROSPACE ENGINEERING IN THE PARTIAL FULFILLMENT OF THE
REQUIREMENTS FOR THE DEGREE OF MASTER OF SCIENCE IN
RENEWABLE ENERGY ENGINEERING**

DEPARTMENT OF MECHANICAL AND AEROSPACE ENGINEERING

LALITPUR, NEPAL

SEPTEMBER, 2022

COPYRIGHT

The author has agreed that the library, Department of Mechanical and Aerospace Engineering, Pulchowk Campus, Institute of Engineering may make this thesis freely available for inspection. Moreover, the author has agreed that permission for extensive copying of this thesis for scholarly purpose may be granted by the professor(s) who supervised the work recorded herein or, in their absence, by the Head of the Department wherein the thesis was done. It is understood that the recognition will be given to the author of this thesis and to the Department of Mechanical and Aerospace Engineering, Pulchowk Campus, Institute of Engineering in any use of the material of this thesis. Copying or publication or the other use of this thesis for financial gain without approval of the Department of Mechanical and Aerospace Engineering, Pulchowk Campus, Institute of Engineering and author's written permission is prohibited.

Request for permission to copy or to make any other use of the material in this thesis in whole or in part should be addressed to.

Head

Department of Mechanical and Aerospace Engineering

Pulchowk Campus, Institute of Engineering

Lalitpur, Kathmandu

Nepal

TRIBHUVAN UNIVERSITY
INSTITUTE OF ENGINEERING
PULCHOWK CAMPUS

DEPARTMENT OF MECHANICAL AND AEROSPACE ENGINEERING

The undersigned certify that they have read, and recommended to the Institute of Engineering for acceptance, a thesis entitled **“Impact in Substation Power Transformer Due to Injection of Non-linear Load”** submitted by Sujit Tiwari in partial fulfillment of the requirements for the degree of Masters of Science in Renewable Energy Engineering.

Supervisor, Assoc Prof. Mahammad Badrudoza

Head of Department, Department of Electrical Engineering

Pulchowk Campus, IOE

External Examiner, Er. Dhupendra Kumar Jha

Deputy Manager

Nepal Electricity Authority

Committee Chairperson, Assoc. Prof. Dr. Surya Prasad Adhikari

Head of Department, Department of Mechanical and Aerospace Engineering

Pulchowk Campus, IOE

Date: September 18, 2022

ABSTRACT

In electrical power system transformer is consider as one of the mostly used major component. The thermal condition of transformer is considered as a critical case while operating in abnormal conditions such as harmonic loading is the main focus of the study. In this thesis, 22.5 MVA, 66/11 kV, ONAF power transformer thermal behavior analysis is carried by using IEEE standard C57.91 model for the study of influence due to nonlinear load and impact on its life which is simulated by using MATLAB software and analyzed. The transformer considered in the study shows the significant life reduction while non-linear loads is injected above 15% of the transformer capacity rating for both winter and summer season. It concluded that higher the harmonic load current there will be additional losses towards transformer windings along with core which cause raise in temperature of transformer higher than the standard operating temperature. This indicates that hot spot temperature increases by 2°C for every 1% increase of non-linear loading of rated capacity of transformer along with 2% increase in size of transformer for the case of winter whereas the increase in temperature is 2.7°C and size increase by 3% in case of summer.

The ambient temperature will directly affect the winding hot spot temperature along with the load current. The worst-case scenario for hottest day of 32°C with average annual load shows exponential behavior in loss of life after 8% of harmonic loading in transformer of its rated capacity. The time for cooling and heat dissipation rate of transformer will also affect in rising of winding hot spot temperature. So, awareness of the effect on increasing non-linear load must be considered while inserting large number of non-linear loads in feeder and designing the next generation of transformer.

ACKNOWLEDGEMENT

I would like to express my deep sense of gratitude to my thesis supervisor Assoc Prof. Mahammad Badrudoza for continuous supervision, consistent support and motivation throughout this work. This research would have never been its way without his guidance and valuable insights. I am sincerely grateful for his steady serenity, understanding and engagement throughout the learning process of this master's thesis.

I would like to thank Associate professor Dr. Surya Prasad Adhikari, Head of Department of Mechanical and Aerospace Engineering, Pulchowk Campus for his support and guidance throughout my time. I would also like to thank the rest of the faculty members of the Department of Mechanical and Aerospace Engineering, for their valuable input and for taking the time to review my thesis.

My special thank Dr. Hari Bahadur Darlami program coordinator of M.Sc. in Renewable Energy Engineering, Pulchowk campus for his feedback, suggestions, comments and advice in this thesis.

I would like to thank Nepal Electricity Authority, Lainchaur Substation for helping me to provide feeder data.

Last but not least, I would like to express my deepest appreciation to my family and my friends for their never-ending love and constant support.

Sujit Tiwari

074/MSREE/019

TABLE OF CONTENTS

COPYRIGHT.....	ii
ABSTRACT.....	iv
ACKNOWLEDGEMENT	v
TABLE OF CONTENTS.....	vi
LIST OF TABLES	viii
LIST OF FIGURES	ix
LIST OF SYMBOLS	xi
LIST OF ABBREVIATIONS.....	xiii
CHAPTER ONE: INTRODUCTION	1
1.1 Background.....	1
1.2 Statement of the Problem.....	2
1.3 Scope of Work	3
1.4 Objectives	3
1.5 Limitation.....	4
1.6 Thesis Organization	4
CHAPTER TWO: LITERATURE REVIEW.....	5
2.1 Background.....	5
2.2 Literature Survey	5
2.3 Distribution System	8
2.4 Transformer.....	9
2.4.1 Types of Transformers	9
2.4.2 Cooling of Transformer.....	13
2.5 Types of Losses in a Transformer.....	15
2.6 Thermal Modelling of Transformer	17
CHAPTER THREE: RESEARCH METHODOLOGY	22

3.1	General	22
3.2	Methodology	22
3.2.1	Top oil transformer temperature model	24
3.2.2	Hot spot temperature model.....	26
3.2.3	Power (Loss) due to non-linear load model	27
3.2.4	Simulation of Transformer Loss of life model	27
CHAPTER FOUR: RESULTS AND DISCUSSION.....		28
4.1	General	28
4.2	Transformer Parameter and Load Profile	28
4.3	Case 1: Results of Power Transformer for Winter Season	30
4.4	Case 2: Results of Power Transformer for Summer Season.....	33
4.5	Case 3: Result for Average Annual Load of Power Transformer.....	35
4.6	Analysis of the Effects for Loading on Loss of Life	37
4.7	Analysis of Hotspot Temperature Towards Non-linear Load.....	40
4.8	Analysis of Non-Linear Loading Towards Sizing of Transformer.....	42
CHAPTER FIVE: CONCLUSIONS AND RECOMMENDATIONS.....		45
5.1	Conclusions.....	45
5.2	Recommendations.....	45
REFERENCES		46
APPENDIX A: TEMPERATURE DATA.....		51
APPENDIX B: SLD OF LAINCHAUR SUBSTATION		52
APPENDIX C: MATLAB CODE		53
APPENDIX D: ANNUAL LOAD DATA.....		60
APPENDIX E: MONTHLY LOAD DATA		61

LIST OF TABLES

Table 2.1 Dynamic Transformer Reading as per IEC 60076-7	21
Table 3.1 Components used for temperature equation (IEEE, 2012)	25
Table 4.1 Rated thermal parameter of 22.5 MVA 66/11 KV transformer with losses	28
Table 4.2 Load Cycle of Transformer.....	29

LIST OF FIGURES

Figure 2.1 Types of Losses in the Transformer	15
Figure 3.1 Simplified diagram for HST with loss of life	23
Figure 4.1 Daily Load Curve for Winter Season	30
Figure 4.2 Cumulative Hot spot Temperature as per Base Load Condition of Power Transformer.....	31
Figure 4.3 Loss of life curve for Winter of Power Transformer.....	31
Figure 4.4 Per unit Life versus hot spot temperature curve for Winter of Power Transformer.....	32
Figure 4.5 Aging acceleration factor curve for Winter of Power Transformer	32
Figure 4.6 Load curve for Summer of Power Transformer	33
Figure 4.7 Cumulative Hot spot Temperature for Summer of Power Transformer.....	33
Figure 4.8 Loss of Life for Summer of Power Transformer.....	34
Figure 4.9 Per unit life versus hot spot temperature for Summer of Power Transformer	34
Figure 4.10 Aging acceleration factor curve for Summer of Power Transformer.....	35
Figure 4.11 Average Annual load curve	35
Figure 4.12 Cumulative Hot spot Temperature for Annual Average Load	36
Figure 4.13 Loss of Life for Annual Average Load of Power Transformer.....	36
Figure 4.14 Effect of Non-linear Loading on Transformer Life (Winter).....	37
Figure 4.15 Effect of Non-linear Average Loading on Transformer Life (winter)	38
Figure 4.16 Effect of Non-linear Average Loading on Transformer Life (Summer)..	38
Figure 4.17 Effect of Non-linear Average Loading on Transformer Life (Summer)..	39
Figure 4.18 Effect of Non-linear Annual Average Loading on Transformer Life	39
Figure 4.19 Effect on hot spot temperature rise due to harmonic loads (Winter)	40
Figure 4.20 Effect on hot spot temperature rise towards harmonic loads (Summer) ..	41

Figure 4.21 Effect on hot spot temperature rise due to harmonic loads for annual average load	41
Figure 4.22 Effect on sizing of transformer in different non-linear loading condition (winter).....	42
Figure 4.23 Effect on sizing of transformer in different non-linear loading condition (Summer)	43
Figure 4.24 Effect on sizing of transformer in different non-linear loading condition for Annual Average Load	44

LIST OF SYMBOLS

Symbol	Description	Unit
A	Constant related to material insulation	[-]
B	Breadth of the transformer	[m]
C	Absolute speed of bubbles	[m/s]
D	Diameter of the conservator	[m]
E	Heat energy	[J]
F_{AA}	Aging Acceleration Factor	[-]
F_{EQA}	Equivalent aging factor	[-]
kV	Kilo Volt	[kV]
kVA	Kilo-Volt Ampere	[kVA]
m	Exponent	[-]
n	Exponent	[-]
P_e	Eddy Current Loss	[W/kW]
P_w	Power loss	[W/kW]
Symbol	Current Density	[A/mm ²]
t	Time interval	[seconds]
VA	Volt – Ampere	[VA]
Δt	Time interval	[seconds]
θ_A	Average ambient temperature during load cycle	[⁰ C]
θ_{amb}	Ambient temperature for transformer	[⁰ C]
θ_{f1}	Top oil rise temperature of transformer	[⁰ C]
θ_H	Winding hot spot temperature of transformer	[⁰ C]
θ_{hs}	Hot spot temperature of transformer	[⁰ C]

θ_{moil}	Bottom oil temperature	[$^{\circ}\text{C}$]
$\theta_{\text{tmoil-moil}}$	Temperature difference between top oil and bottom oil	[$^{\circ}\text{C}$]
θ_{top}	Top oil temperature	[$^{\circ}\text{C}$]
θ_{u}	Hot spot temperature rise	[$^{\circ}\text{C}$]
$\theta_{\text{uhs-toil}}$	Temperature difference between hot spot oil and top oil	[$^{\circ}\text{C}$]
τ_{hst}	Hot spot time constant	[seconds]
$\Delta\theta_{\text{H}}$	Hot spot temperature over top oil raise temperature	[$^{\circ}\text{C}$]
$\Delta\theta_{\text{Hi}}$	Initial hot spot raise temperature	[$^{\circ}\text{C}$]
$\Delta\theta_{\text{Hu}}$	Ultimate hot spot raise temperature	[$^{\circ}\text{C}$]
$\Delta\theta_{\text{Toil}}$	Top oil raise temperature over ambient temperature	[$^{\circ}\text{C}$]
μ_{pu}	Viscosity of oil	

LIST OF ABBREVIATIONS

Abbreviations	Description
AC	Air Conditioners
DR	Demand Response
DTR	Dynamic Transformer Reading
EHV	Extra High Voltage
EV	Electric Vehicles
IEC	International Electro-Technical Commission
IEEE	Institute of Electrical and Electronics Engineers
LDT	Large Distribution Transformer
MATLAB	Matrix Laboratory
MDT	Medium Distribution Transformer
ODAF	Oil Directed Air Forced
ODWF	Oil Directed Water Forced
OFAF	Oil Forced Air Forced
ONAF	Oil Natural Air Forced
ONAN	Oil Natural Air Natural
PF	Power Factor
SDT	Small Distribution Transformer
SMPS	Switch Mode Power Supply
THD	Total Harmonic Distortion
UHV	Ultra High Voltage

CHAPTER ONE: INTRODUCTION

1.1 Background

In modern years, large number of non-linear loads are being connected to the power grid. Transformer is considered as expensive and major component of power system networks. As, it is always in continues operation so, the attempts are always made to prevent it from failure. For power system networks and its operations, reliability of transformer is critical issue as well as its efficiency in order to prevent system from blackouts and economical losses. Normally, insulation breakdown is the common cause for transformer failure. Traditionally, operation of transformers is considered under sinusoidal wave form where electromagnetic, electrical and mechanical aspects and its parameters are estimated within such conditions. The life span of the transformer is mainly estimated by its remaining life of windings insulation level that is directly affected by losses in the transformer. But transformers nominal life span is basically depended on condition of sinusoidal wave form. The main problem of non-sinusoidal waves of current experienced in the modern electric devices are from nonlinear loads as electronic and electrical equipment have built-in feature with electronic components that is used for control mechanism and to make efficient use of energy (McBee, Rudraraju, and Chong 2019; Mohsenzadeh et al. 2016). The examples of commonly used nonlinear loads are personal computers, uninterrupter power supplies, power electronic equipment's, variable speed drives, electric vehicle battery charger, arc and induction furnaces.

These days there is increase of the harmonic loads which adds stresses on the electrical transformers by increasing their built-in losses and consequently the devices have to go through premature aging or even failure (Cazacu, Petrescu, and Ionita 2017). Due to increase in nonlinear loads non-sinusoidal currents will pass through the network which will generate harmonics in the power system. Harmonics in the system increase the losses of transformer leading to temperature rise. The hot spot temperature rise affects the insulation level of transformer leads to insulation breakdown.

Aging of transformer insulation is in close relationship with humidity level, temperature and the percentage of oxygen level contain in the air. These days, change in design and construction of transformer has terminated the impact of oxygen and moisture level on the oil of transformer. Therefore, the dominance of these factors can be ignored due to

which transformer life is reduced. The unsettled factor is temperature due to which the transformer life is affected severely (Fuchs, Lin, and Martynaitis 2006). The temperature distribution of transformer in overall surface is not uniform so in order to identify the prominent temperature in transformer part which adds in the transformer loss of life i.e., highest temperature part called as hotspot of the transformer is used. There are lots of factors which affect temperature so that the reduction in service life of transformer cannot be identified correctly even if it is considered under constant and controlled or uncontrolled and conditions (Yildirim and Fuchs 2000). The hot spot winding temperature and insulation level of transformer are considered as basic factor which limit the transformer loading capacity. So, the loading capacity of transformer is totally dependent on the temperature of winding hot spot of the transformer. Therefore, the change in temperature of transformer will influence in the capacity of loading.

The generated heat in the transformer because of the losses should have to be transferred into the oil of transformer and from the oil to the environment. The extrinsic conditions like ambient temperature, velocity of wind and the solar heating direction will affect in the dissipation of heat from the transformer. The ambient and hot spot temperature are the key factor in identifying the rate of transformer aging whereas different loading level will affect the aging of winding insulation. Hence, for normal condition the nature of load with their respective loss is the major factor in winding hot spot temperature rise and potentially life loss of transformer.

1.2 Statement of the Problem

The transformer has crucial role and it is considered as the major part of the electrical system network because of many reasons such as, it is so costly and it has direct effect on operation of network. So, it must be protected from failure otherwise will affect the electrical network and result into blackout condition. The oil temperature rise is considered as main reason for transformer failure. The rating of transformer is determined by winding temperature which limits the transformer loading therefore, the oil of transformer must remain in its standards as per manufacture. The whole winding temperature of the transformer is not uniform. Therefore, the standard value is identified by the highest temperature of the transformer winding section. This temperature of the winding insulation represents the major factor for aging of transformer. The rise in ambient temperature and the temperature increases due to loading experience the greater loss of life percentage in transformer (Afifah et al. 2019),

(Sönmez and Komurgoz 2018). As, non-linear loads are being increased continuously which will supplement hot spot temperature rise of transformer (Sönmez and Komurgoz 2018). It is important to understand behavior of temperature rise in the transformer with the changes in harmonic loading, and how these changes have effect in the transformer lifespan. So, a designed model is expected to calculate the winding hot spot temperature of transformer on different non-linear loading, ambient temperature and the impact in sizing of the transformer.

1.3 Scope of Work

To explore a comprehensive model for power transformer in which thermal behavior of transformer is studied in a feeder system is the scope of this thesis. The main aim of this thesis is to develop a relationship between the hot spot temperature raise due to nonlinear loading. Furthermore, the injection of non-linear load in feeder are studied in this project by finding the maximum limits of non-linear load injection in order to determine winding hot spot temperature of transformer and identify the nominal age of the transformer along with the change in rating capacity.

In the analysis process we need to collect the real time data properly. In case of hot spot temperature calculation, the ambient temperature should be noted accurately with the cooling fans status either on or off. The IEEE Standard C57.91 model is used in this thesis with the help of MATLAB software to study impact of nonlinear load on transformer.

1.4 Objectives

In this thesis a model is designed and the thesis main objective is to analyze the hot spot temperature of transformer on different percentage of non-linear loading, ambient temperature conditions and the impact in sizing of the transformer.

To achieve the aim objective several specific objectives have been defined, which is listed below

- To calculate the transformer loss of life due to non-linear load
- To calculate the winding hot spot temperature rise of transformer due to non-linear loading
- To calculate the increase in transformer rating capacity due to non-linear loading

1.5 Limitation

This dissertation discusses on the transformer temperature rise effect on the aging of the distribution feeder transformer but limited to technical operation of transformer in variant temperature. It does not consider size of transformer, manufacturing techniques and initial loading effect. It only provides information about the impacts of hot spot temperature variation on operating range. It will not specify the required system for protection which could be used for transformer in coordination with grid system. The percentage of tapping and initial loading effect of transformer are not discussed in this dissertation.

1.6 Thesis Organization

The dissertation consists of five chapters and the other parts of the thesis are as follows:

Chapter 1 presents a brief introduction of power system along with transformer and nature of loads. The problems are also stated and presents the main and specific objectives of this dissertation along with scope and limitation of the work.

Chapter 2 presents a literature review on background of transformer in distribution feeder system, transformer types and cooling techniques of transformer. Mathematical modelling on thermal effect of transformer with nonlinear loads are also presented based on IEEE standard.

Chapter 3 proposes the methodology for the study of impact on distribution feeder transformer due to percentage of nonlinear loading. The methodological tools and paradigm are also presented.

Chapter 4 In this chapter, demonstration of results presented for the transformer loss of life due to nonlinear loads in substation power transformer of Nepalese case.

Chapter 5 provides the conclusion and summary of outcomes with recommendations on the future works.

CHAPTER TWO: LITERATURE REVIEW

2.1 Background

In the electric power network system, it includes generation, transmission and distribution of energy. The reliability of power system is the ability of power system to addresses the issues of service interruption along with power supply loss. It is mandatory of electricity authority to maintain the reliable supply system when it leads to concern of security and adequacy.

Different types of loads are being used by consumers in day-to-day life for the comfortable and easy life. The consumption of energy by every household are being increasing everyday where different locality has their own consumption pattern. The installing capability of different electrical devices and gadgets depends on earning. Rich people commonly use luxury and expensive system like washing equipment, air conditioners, water Geyser etc. In country like Nepal, power is consumed by household only for conventional types of lighting loads which are generally single-phase power supply. The impact of loads due to consumption by all households in the distribution system can be analyzed by utilizing load templates which helps to determine the system parameters like power, PF, THD and energy requirements. In residential area, different types of loads are being used by different household in which most of are lighting loads and inductive loads like water pump, fan, AC, washing machine etc. At the consumer end use of large number of solid-state devices are the reasons for a power quality issue which is known as harmonics which distort the sinusoidal wave of power supply due to nonlinear nature of load (Abbas and Saqib 2007)(Tan et al. 2012). Nonlinear loads draw current while appliances are in on state where it does not obey ohms law and the impedance of the circuit is not linear. Because of this reason non-sinusoidal currents will be introduced in the system. The increasing trends of latest nonlinear loads such as, induction cooking, LED lamps, PEVs etc. has negative impacts in the nominal life span of numerous assets of the distribution network like transformer, conductors, protection systems, etc. (Caicedo, Romero, and Zini 2017).

2.2 Literature Survey

Ming -Yin Chan conducted a case study in an office building in which lots of computers are being as a major source of harmonics. The study highlights on the effects of harmonic distortion due to load current and voltages on distribution systems. It also

recommends that the proper planning and designing in electrical systems could reduce the harmonic-related problems (Chan, Lee, and Fung 2007).

Fang Z. Peng presented over the characteristics of the harmonics due to non-linear loads which are characterized into two types of harmonic sources, namely current source non-linear loads and voltage source non-linear loads. These types of harmonic sources are completely distinctive and exhibit dual properties and characteristics based on which the current-source nonlinear loads and voltage-source nonlinear loads have their own suitable filter configurations. The personal computers which draw non-sinusoidal current with odd harmonics has effect on power system more significantly. The distribution networks is severely affected due to flow of generated harmonics at the time of the operation of electronic load and also lowers the power quality (Peng 2001).

Gruzs discusses on the survey that shows across the computer sites in U.S. which results 22.6% of those sites having neutral current crossing the full-load of phase currents because of the non-linear character of the load. Nowadays in computer systems, due to use of line-to-neutral type SMPS devices, there is increase in the percentage of high neutral current in comparison with older computer systems. Also, larger number of neutral currents being observed even if there are balanced phase currents. This is the reason which cause overloaded transformers and feeders along with distortion of voltage and common mode noise in the system (Gruzs 1990).

A.C. Liew demonstrated larger neutral current are caused due to three major components, i.e., third harmonic currents which is caused due to saturation of inductive ballasts of fluorescent lamps, 50-Hz unbalance system, and nonlinear nature of lamp arc. The due to presence of third harmonic distortion of voltage waveform in the phase voltage will cause more value of third harmonics distortion level in current waveform (Liew 1989).

M. Sharifian studied the non-linear load will affects the system due to intake of non-periodic or non-sinusoidal currents, like semiconductor devices, induction furnaces electrical furnaces, welding machines and so on. The study also concludes that the effects is reason for overload of the system and also the cause for reduction in the performance of the system along with its efficiency. It can have devastating effects on the neighborhood load of such types of non-linear loads (Sharifian, Ali-abbasi, and Pourazar n.d.).

W. Abbas explore that nonlinear load shows higher effect in distribution system regarding THD at different voltage levels. It also explains that the concentration of nonlinear load at lower voltage system has maximum impact of harmonics in lower bus voltage system. The increase rate of THD in the system is more significant in lower bus system rather than in higher voltage bus. (Abbas and Saqib 2007).

S. Shrestha organizes paper in which high EV penetration in a medium voltage distribution system has greater impact when EVs are under uncoordinated charging practice will create a new load peak within the system and creates the condition of undervoltage problems of the local grid (Shrestha and Hansen 2016).

T. A. Abdul-Hameed observed the system to be unstable with the existence of large nonlinear loads in the network of distribution system which remarkably introduce harmonics distortion into the network. The level of distortion in percentage due to the harmonics i.e., THD is 112.04% at maximum which is a major deviation from the IEEE standard 519-1992 specification of 5% maximum for distribution network below 69KV (Abdul-Hameed et al. 2019).

G. Eduful introduced a harmonic suppressor which have capability to reduce the harmonic energy losses however it is noticed to increase in the level of harmonic voltage distortion. This is a drawback of suppressors because high voltage THDs will lead to an abnormal condition of electronic devices (Eduful and Atanga 2017).

A. Collin presented a simulation for a real scenario of mixed-type low and high-power SMPS equipment connected in the low-voltage system network having impedance values of typical system and results in higher effects of harmonic cancellation are in the case of mixed-type. The effects of voltage waveform distortions due to harmonic cancellation include the investigation of harmonic voltage wave propagation towards higher system voltage levels are still the issue of future work (Collin, Cresswell, and Djokić 2010).

X. Yijun studied harmonic effects in the electric vehicle loading and its impacts on the distribution system suggested that charging of EV battery in higher state of charge will cause less negative impact to the system and the battery. Paper also informs that the locations of EVs charging station have to be chosen far away from the transformers and the charging stations should be close to the industrial areas as well as renewable energy source, which is itself a source of harmonic, have limitation on the number of EVs.

Underground cable is more susceptible to impact of EV harmonics rather than in the overhead line (Xu et al. 2015).

B. Salvatierra concluded that the modified SPWM modulation presents best performance for heating applications induction as the modified SPWM modulation presents a lower harmonic content than that presented with trapezoidal modulation (Salvatierra et al. 2017).

2.3 Distribution System

The electrical power distribution system provides the power supply to every individual consumer premises which is transmitted through lower voltage level comparison to power transmission over larger distances (i.e., long transmission lines). Distribution networks system is used for distribution of electric power. Distribution networks includes the following system:

1. Distribution substation
2. The primary distribution feeder
3. Distribution Transformer
4. Distributors
5. Service mains

The transmission of electric power system is stepped down on the substations for primary distribution feeder used for distribution purposes. Transmission of voltage, Protection and switching, Regulation of voltage, Metering etc. are the basic functions of distribution substation.

The primary distribution system consists of feeders coming out from the substation and supplying power to several secondary distribution systems. The overhead primary distribution feeders are being hold up mainly by supporting poles in which the strand aluminum conductors are placed on the arms by the help of pin insulators in the pole. Generally, in the crowded places, underground power cables may be used in primary distribution.

Distribution transformers mainly consist of pole mounted type with 3 phase system. The low voltage side of transformer is connected to distributors to fed electric power by the help of service mains which may be three phase or single phase (one phase from the single-phase feeder and a neutral).

The service mains are being tapped out from different points of the distributors which can also be known by distributors and sub-distributors. The distributors have direct connection to the secondary of distribution transformers but sub-distributors are being tapped out from distributors. Depending upon the position and agreement of consumers service mains line of the consumers are connected to the distributors or the sub-distributors.

2.4 Transformer

2.4.1 Types of Transformers

In the power system, various kinds of an electrical transformers can be seen installed, according to their applications. Despite their constructional differences, all transformer works on the same basic law of electromagnetic induction (McLyman and William 2011; Turowski and Turowski 2014), discovered by Michael Faraday in the 19th century. One of the basic classifications is done according to their construction design and can be categorized into core type transformer and shell type transformer (Heathcote 2007; Vecchio et al. 2018).

Core type Construction

In core-type construction, the limbs are surrounded concentrically by the main winding (Heathcote 2007). The magnetic circuit is surrounded by the windings having legs formed with two common yokes (Anon 2002). Since, the transformer is typically arranged to create an overlapping point with an extra pair of lamination to make for an accurate core thickness (Turowski and Turowski 2014), core type has the advantage of preventing condensed flux leakage and iron loss (McLyman and William 2011). But the major benefit of constructing in core type is its constructional cost. For single phase core type, only a pair of limbs and a pair of yokes are required while for conventional three-phase, only three limbs and a pair of yokes are required (Kulkarni and Khaparde 2017). The lower core volume also means its core loss i.e. hysteresis loss and eddy current loss (Ziger, Trkulja, and Stih 2018) are also reduced, as both losses depend upon core weight. This also lowers higher operating efficiencies. Apart from cost reduction, the core type has also better cooling abilities since the core is more open to free circulating oil (Ziger et al. 2018). Despite the core type possessing higher benefits, it also has some limitations. It is less mechanically strong as compared to shell-type construction (Vecchio et al. 2018). When the size of three phase transformer increases,

the height of the limb also increases. This possesses lots of logistic challenges. To reduce overall transformer height, a five-limb core type construction is done (Heathcote 2007).

Shell type Construction

In shell-type construction lamination containing the core of iron, surrounds the part of windings which normally enclose a larger portion of them (Anon 2002). Unlike in core type, where low voltage winding and high voltage winding are wound concentrically, shell type construction has high voltage and low voltage stacked side by side (Vecchio et al. 2018). This gives sandwich structure but most importantly, the leakage flux is reduced considerably (McLyman and William 2011) and consequently lowers the reactive power consumption (Ziger et al. 2018). This lower the number of turns of coils and consequently reduces the magnetizing reactance of the transformer (Hurley and Wölfle 2013; McLyman and William 2011). Since the low voltage and high voltage winding are stacked alternately side by side, they have higher mechanical, and dielectric strength and higher short-circuit strength (Kulkarni and Khaparde 2017). Additionally, they also have considerable seismic-withstand abilities therefore, they can hold out against difficult transportation demands. So, transformers could be shipped throughout different medium, like as air, sea, and land they could be transported from one site to other considering the dimensional limitations (Vecchio et al. 2018). Although power transformers are mostly core type constructed, shell forms are very common on the distribution side of the power system (Heathcote 2007; Vecchio et al. 2018; Ziger et al. 2018).

According to power rating, the transformers can also be categorized into power transformers and distribution transformers (Anon 2002; Heathcote 2007; Vecchio et al. 2018).

Power transformer

Any transformer that transfers electrical power between the generator terminal circuit and the distribution primary circuits are considered a power transformer (Anon 2002). The power transformers are being constructed based on the application, having the prominence on the custom design becoming essential as the rating of power or size of the transformer increases (Harlow 2012). Power transformers are being available for the step-up operation, where it is mainly used at the generator side and also used for

generator step-up (GSU) by the transformers, and for the purpose of step-down operation, mostly used to in distribution circuits. The power transformers are being available as single or three phase apparatus. *Harlow, H.J* (Harlow 2012) writes loosely grouped the power transformer into three basic segments based on output power rating. Those capable of 500-7500 kVA are kept in small power transformer categories while 7.5-100 MVA-rated transformers are grouped into medium and above 100 MVA-rated transformers are considered large power transformers. Additionally, the power transformer is subjected to a higher voltage level (Anon 2013). GSU stepped up the generator terminal voltage of about 11-20 kV to transmission voltage level ranging from 220 kV and above. As such transient overvoltage protection became critical to keep insulation within the permissible limit. According to transformer manufacturer, ABB, GSU up to 1100 MVA ratings have been so far constructed (Anon 2013). The power transformer can be constructed in either three phases or a single phase. The choice of using either a single one of the three-phase transformer or separate three units of single-phase transformer largely depends upon operating efficiency, cost of installation, reliability, and logistic challenges (Anon 2013; Harlow 2012; Hurley and Wölfle 2013; Ziger et al. 2018). The use of a three-phase transformer incurred lower operating core loss and required lower installation investment, but with reduced reliability. Meanwhile where logistic challenges are to become a limiting factor, single-phase transformers are used (Anon 2013).

Distribution Transformer

Distribution transformers transfer electrical power from the primary distribution system to a secondary distribution system or the consumer's service part (Anon 2002). Unlike the power transformer, the distribution transformers are constructed by the manufacturer according to standard power ratings and voltage ratings (Anon 2013; Harlow 2012). Just like power transformers, the distribution transformer can also be sub-classified into various types. *ABB* classified transformers having a power rating of 5000 kVA and above with primary voltage up to 72.5 kV as Large Distribution Transformer (LDT), 400-5000 kVA rating with up to 36 kV primary voltage as Medium Distribution Transformer (MDT), and those up to 315 kVA rating and a primary voltage of up to 36 kV as Small Distribution Transformer (SDT) (Anon 2013). The American and European standards differ in power distribution systems. Even though both American and European employ the same three-phase primary distribution system, the

American system installed a single-phase secondary distribution transformer ranging from 10-250 kVA rating while European system has three-phase secondary distribution transformer ranging from 30-500 kVA rating (Anon 2013). The distribution transformer always stepped lower down the transmission level of voltage to lower the distribution voltage level and mostly has three-phase construction (Harlow 2012; Heathcote 2007; Vecchio et al. 2018). Unlike the power transformers which are operated either fully ON or fully OFF to reduce high core loss, the distribution transformers are operated continuously (Anon 2013; Harlow 2012). Since distribution transformers are operated under various loading conditions, they are constructed in such a way so that they incurred lower core loss (Hurley and Wölfle 2013). The performance of either of the transformer largely depends upon the environmental aspects and the cooling system they employ (Anon 2002; Ziger et al. 2018).

From the fundamental law of electromagnetic induction, the voltage induced is directly dependent upon the number of turns of the coil (McLyman and William 2011; Turowski and Turowski 2014). As the voltage level of the power transformer increases, so does number of the turns in the winding part. Constructing high voltage power transformer with isolated primary and secondary winding increases lots of expensive copper costs and not to mention the bulkier size of an already logistically challenged power transformer. Literature (Anon 2013; Harlow 2012) suggests using the single winding transformer as an alternative solution to the cost escalation problem.

Autotransformer

An autotransformer is the electrical transformer where a common section have minimum two windings (Anon 2002; Anon 2013). This means an autotransformer has a single part of winding transformer with a portion of same winding acting as both the part of winding of the transformer (Kulkarni and Khaparde 2017; Turowski and Turowski 2014). With only one winding, the autotransformer is smaller in size, cost less, and is lighter to transport (Anon 2013). Autotransformer is always had shell-type construction and their winding are wound on a central limb thus it has lower leakage reactance (Vecchio et al. 2018). Autotransformer also has lower losses since the copper loss is reduced considerably as compared to two-winding transformers (Ziger et al. 2018). Additionally, it also has a lower value of excitation current and the increased VA rating for a selected size and mass (Anon 2013). Literature (Heathcote 2007) states autotransformer is more economical as compared to both winding transformer to the

voltage of ratio 3:1. Autotransformer does have a limitation, with a major drawback being autotransformer not able to give electrical isolation (Harlow 2012). When used in a three-phase power system, it also has limitations for incapable of suppressing the harmonic currents and instead acting as if another source of the ground fault currents (Kulkarni and Khaparde 2017).

Against all odds, autotransformers are being used in the power systems extensively. In extra-high voltage (EHV) system and those in ultra-high voltage (UHV) system power transmissions, only autotransformers are installed (Anon 2013; Harlow 2012). The autotransformer's drawback of not isolating the electrical circuits is protected by the use of fast-acting circuit breaker (Anon 2013). Variable autotransformers e.g. variac, are used in industry and laboratories to provide variable voltage as per requirement (McLyman and William 2011). Another type of autotransformer known as zigzag transformer which is used for providing grounding on the three-phase systems otherwise they have no connection to the ground. A zigzag transformer helps to provides an appropriate path for the zero sequence component of the current (Harlow 2012; Vecchio et al. 2018).

2.4.2 Cooling of Transformer

The life of the transformer depends upon the life of the insulating paper used inside it. The insulating paper undergoes thermal degradation undue course of time and is greatly influenced by the operating temperature (Feng, Wang, and Jarman 2014). Hence, effective cooling is necessary to ensure that its insulation survives the predicted lifespan. Literature (Anon 2002) suggested following transformer cooling classes which are practiced to date.

Oil Natural Air Natural (ONAN)

In this class, the transformer's core and windings are immersed in the mineral oil or the synthetic insulating fluid having a fire point value of less than or equal to 300°C (Feng et al. 2014). The cooling is done by effective natural circulation of air over the cooling surface i.e., tank.

Oil Natural Air Force (ONAF)

In this class, the insulating fluid or mineral oil has a value of fire point less than or equal to 300°C. The circulation of oil inside the transformer's tank occurs naturally while the

transformer's tank surface and radiating fins are provided with a cooling fan. The cooling fan pumps the cold ambient air, thus giving forced circulation of air (Feng et al. 2014). Generally, the transformers are manufactured with ONAN/ONAF functionality. When the lower rating of the transformer is required, cooling is done via natural air circulation while for a higher rating of transformer, forced air circulation is performed. This class of transformer has a higher rating as compared to ONAN class and is used in power transformers of substations (Feng et al. 2014).

Oil Forced Air Forced (OFAF)

This class of transformer also has an oil temperature limit of 300°C. The cooling of the transformer core is achieved by the forced circulation of the insulating fluid used as non-directed flow (Feng et al. 2014). The insulating fluid is cooled by the external insulating fluid-to-air heat transfer equipment used for forced circulation of the air over in its surface for cooling. This class of transformer has a higher rating and is more compact in construction than ONAF class.

Oil Directed Air Forced (ODAF)

This class of transformer also has an oil temperature limit of 300°C. The cooling of the transformer core is achieved due to forced circulation of the insulating fluid used for directed flow (Feng et al. 2014). The ducts are placed alongside the insulating material between the windings and core, through which the oil flows. Since the oil flows directly through the core and winding, the cooling method is much more effective as compared to OFAF. The insulating fluid is being cooled by external means of insulating fluid-to-air heat transfer equipment used for forced circulation of air over the surface of cooling. This class of transformer has a higher rating and is more compact in construction than OFAF class.

Oil Directed Water Forced (ODWF)

This class of transformer also has an oil temperature limit of 300°C. The cooling of the transformer core is achieved due to forced circulation of the insulating fluid used for directed flow (Feng et al. 2014). Just like in ODAF, the ducts are placed alongside the insulating material between the windings and core, through which the oil flows. The insulating fluid is being cooled by using external insulating fluid-to-water heat transfer equipment used for forced circulation of water on the surface of cooling. The hot water is again cooled by water to the air heat transfer equipment used for forced circulation

of air on surface of cooling. This class of transformer has the highest rating and is more compact in construction than ODAF class.

2.5 Types of Losses in a Transformer

In transformers it includes different types of the losses as iron loss or core loss, the hysteresis loss and eddy current loss, copper loss, stray loss along with dielectric loss. The core losses in the transformer happens due to variation of the magnetization in the transformer core and the copper loss is due to winding resistance of the transformer.

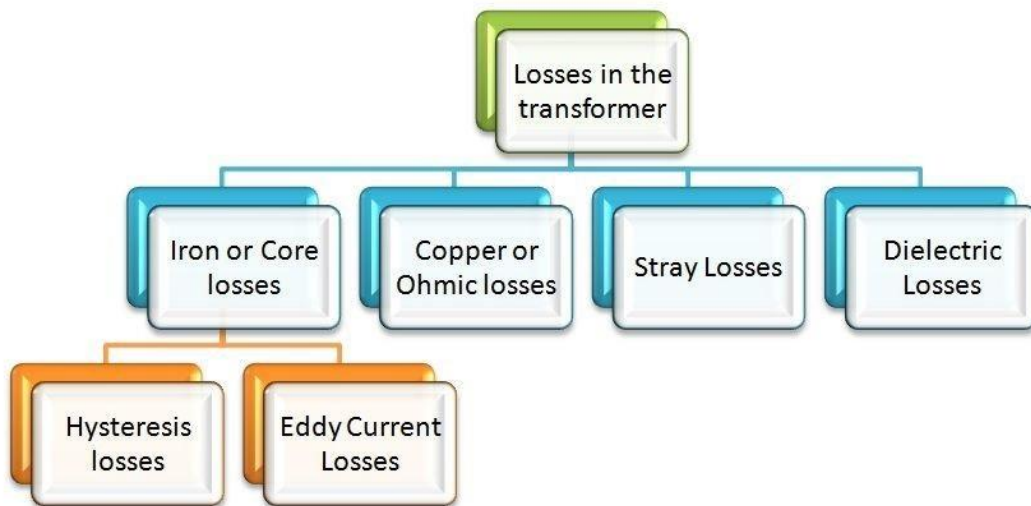

Figure 2.1 Types of Losses in the Transformer

Iron Losses

Iron losses occurs due to the alternating flux in the core of transformer known as core loss. Iron loss is further classified into hysteresis and the eddy current loss.

Hysteresis Loss

As, the transformer core is under the influence of an alternating magnetizing field, for every cycle of emf, a closed loop of hysteresis is traced out and the size of loop determines the power dissipated in the heat form known to be hysteresis loss. The equation for hysteresis loss is given by:

$$P_h = K_\eta B_{max}^{1.6} f V \quad (2.1)$$

Where,

- K_η is proportionality constant which is dependent on the volume and quality of material
- f is the supplied frequency
- B_{max} is the maximum flux density.

The use of material like silicon steel for the core construction of transformer helps to minimize the iron losses.

Eddy Current Loss

When the flux is linked with a closed circuit of any conducting material, an emf is induced which cause current flows within the circuit. The value of current is dependent on the amount of emf induced around the circuit along with its resistance. Since the core is of conducting material due to which induced emf circulate currents within the material part. This circulating currents in the core are known as eddy currents. It happens during a changing magnetic field that is experienced by conductor. These currents are useless and not responsible for doing of any work. It only produces a loss in the magnetic material known to be eddy current loss. This current loss can be reduced by constructing the core having stack of thin laminations. The formula for eddy current loss is obtain by equation (2.2):

$$P_e = K_e B_m^2 t^2 f^2 V \quad (2.2)$$

Where,

- K_e – coefficient for eddy current loss and based on the nature of magnetic material, its resistivity and the thickness of laminated core
- B_m – the maximum flux density of material in wb/m²
- t – thickness of core lamination measured in meters
- f – supply frequency of magnetic field in Hz
- V – the total volume of the material in meter cube

Copper Loss or Ohmic Loss

Copper losses occurs due to dc resistance of the windings in transformer. Therefore, the total copper losses are given by following equation:

$$P_c = I_1^2 R_1 + I_2^2 R_2 \quad (2.3)$$

where value of I_1 and I_2 are the transformer primary and secondary current and R_1 and R_2 are gives dc resistance value for winding of primary and secondary sides then the $I_1^2 R_1$ and $I_2^2 R_2$ respectively gives loss on both the winding sides. These losses varied as per the loading condition of transformer and also known to be variable losses and its losses changes as the square of the current load.

Stray Loss

The stray losses are occurred because of the presence of magnetic field leakage in the transformer. Normally, the part of stray losses is in small value comparison to the core and copper losses. Therefore, it can be ignored in general case.

Dielectric Loss

Dielectric loss in the transformer occurs due to decrease in quality of insulating material that is the oil or the solid insulations. The transformer efficiency gets affected due to deteriorating of oil and solid insulation.

2.6 Thermal Modelling of Transformer

There is a proportional relationship towards operating temperature and the aging rate of transformer is known. For the increase in ambient temperature results in an increase loading of transformer which leads for reduction in the life of transformers and the value of insulation will be decreased because of polymerization. As the ambient temperature increases, it will increase the top oil temperature which results in a decrease in load ability and reliability of the transformers and leads to an increase in winding hot spot temperature. Remaining factors affecting the thermal behavior of the transformers are as follows:

- Nominal life Expectancy loading
- Planned loading
- Long period overloading
- Short period overloading
- Design of transformer
- Rise of temperature at rated load
- Load factor

➤ Time of overload

The ambient temperature and the operation temperature increase will give rise to thermal aging of transformers and need to be control a loaded transformer in order to mitigate the effect of aging. The electricity demand fluctuates at some time of day, week, and months or in different seasons, the balancing of supply and demand of electricity needs to provide the right capacity of electrical power supply in order to match the changes towards demand side (Rudnick et al. 2014). According to the US Department of Energy (U.S. Department of Energy 2013) demand response defines the benefit to power grid and system reliability as well as power quality when system is in balanced condition.

The thermal model design for a transformer is based on the Institute of Electrical and Electronics Engineers (IEEE) and International Electro-Technical Commission (IEC) standards. The IEEE and IEC standards for thermal modeling of transformers are IEEE Standard C57.91, IEC Standard 354, and IEC Standard 60076 are discussed and also used in this thesis.

IEEE Standard C57.91

According to IEEE standard C57.91, the higher limit of ambient temperature for the transformer is 40⁰ Celsius and the ambient temperature have to be below 30⁰ Celsius. The winding hot spot temperature is restricted not be greater than 110⁰ Celsius and the average winding temperature also should not exceed 65⁰ Celsius above the ambient temperature of the environment. The equations for time and life of transformer based on temperature are governed by equation (2.4) and given as (IEEE 2012; Lesieutre, Hagman, and Kirtley 1997; Tylavsky et al. 2000),

$$T_h \frac{d\theta_h}{dt} + \theta_h = \theta_{hu} \quad (2.4)$$

The nominal life loss is given by,

$$LOL = 100t(10^{-[A+\frac{B}{T}]}) \quad (2.5)$$

The average normal life of the transformer is calculated from equation (2.6),

$$F_{EQA} = \frac{\sum_{n=1}^N (F_{AA,n} \Delta t_n)}{\sum_{n=1}^N \Delta t_n} \quad (2.6)$$

In the standard, the change in loading of the transformer because of loading loss, losses towards the winding and naturally changed with the cooling mode is related to and governed by the equation (2.7),

$$T_0 \frac{d\theta_{top}}{dt} = -\theta_{top} + \theta_{amb} + \theta_u \quad (2.7)$$

The winding hot spot temperature derived from heat transfer theory and the thermal dynamic electrical analogy is given by model and is presented in *Tan, L. et al.* (Tan et al. 2012) and is given as in equation (2.8),

$$\theta_{hs} = \theta_{amb} + \theta_{moil} + \theta_{toil-moil} + \theta_{hs-toil} \quad (2.8)$$

In the standard, the effect of load variation, solar radiation and ambient temperature on the heat transferred are considered. The thermal model of a transformer based on the heat transfer theory and it introduces viscosity of oil change and loss variation to decrease the impact of temperature difference. Equation (2.9) shows the relationship between power loss, oil temperature, and viscosity.

$$I^2 P_{W,pu}(\theta_{hst}) (\mu_{pu} \theta_{hst,r})^{\frac{1-n}{n}} = (\theta_{hst} - \theta_{oil})^{\frac{1}{n}} + \tau_{hst,r} (\mu_{pu} \theta_{hst,r})^{\frac{1-n}{n}} \left(\frac{d\theta_{hst}}{dt} \right) \quad (2.9)$$

The transformer top oil temperature change is related to winding hot spot temperature and the ambient temperature (IEEE 2012) and is given in equation (2.10),

$$T_0 \frac{d\theta_{top}}{dt} = -(\theta_{top} - \theta_{amb})^{\frac{1}{n}} + \theta_u \quad (2.10)$$

According to the *IEEE guide* (IEEE 2012), and *Jauregui-Rivera, L et al* (Jauregui-Rivera and Tylavsky 2008), these are appropriate for oil forced and air forced cooling but not practical for the oil natural air natural cooling transformer.

IEC Standard 354

In this standard (Perera and Lucas 2015; Simonson 1998), the transformer of optimum capacity is selected to check the operation of the existing transformer. The hottest spot temperature can be calculated by equation (2.11) and is given as,

$$\theta_h = \theta_a + \Delta\theta_{on} + \Delta\theta_{td} \quad (2.11)$$

The relation for top oil temperature is given by equation (2.12),

$$\Delta\theta_{on} = \Delta\theta_{0(n-1)}(e^{-\tau_0^{-t}}) + \Delta\theta_{0un}(1 - e^{-\tau_0^{-t}}) \quad (2.12)$$

The aging of the transformer towards the loss of life is the basis of aging rate and is calculated from equation (2.13),

$$LOL = \frac{h}{3T} \left(\sum 4V_{odd} + \sum 2V_{even} \right) \quad (2.13)$$

For the stationary equilibrium of natural oil in the transformer, an practical relation between heat exchange and the electric circuit law can be made on the basis of a thermal model including heated conductors, heated capacitors and the heated current sources. The relation between hot spot temperature and top oil temperature for a specific load scenario (Tang, Wu, and Richardson 2004) can be found in the equation (2.14),

$$\theta_{hst} = \theta_{oil-out} + \theta_{amb} + \Delta\theta_h = TOT + \Delta\theta_g K^y \quad (2.14)$$

The equivalent circuit can be used to load current and determine the winding power loss.

IEC Standard 60076

This standard gives a guideline for the specification and percentage loading of the distribution transformers in regard to operating temperature and the thermal aging. Mathematical models are used to calculate percentage loading with different temperatures. The dynamic transformer reading (DTR) algorithm which is based on IEC 60076 standard which used the following inputs and provide the following outputs (Commission 2005) as represented in Table 2.1.

Table 2.1 Dynamic Transformer Reading as per IEC 60076-7

Inputs	Outputs
<ul style="list-style-type: none"> ➤ Load of transformer ➤ Top oil temperature ➤ Ambient temperature ➤ Tapping position ➤ Types of cooling 	<ul style="list-style-type: none"> ➤ Dynamic ratings ➤ Winding hot spot temperature ➤ Loss of life

The insulation of paper will find out the aging rates which is calculated in two different conditions as given in *Jalal T.S. et. al.* (Jalal, Rashid, and Van Vliet 2012),

a) Non-Thermally upgraded paper

$$V = 2^{\frac{(\theta_h - 98)}{6}} \quad (2.15)$$

b) Thermally upgraded paper

$$V = \exp\left(\frac{15000}{373} - \frac{15000}{\theta_h + 273}\right) \quad (2.16)$$

Similarly, the algorithm is used to predict different pre-loading and overloading conditions. However, different technical challenges will occur in this algorithm for applying to all types of power transformers in the system network and the accuracy of measured or the transformer winding hot spot temperature (Jalal et al. 2012).

Arrhenius chemical reaction rate law can be applied for calculating the relationship for the thermal aging characteristics of insulation materials. This method is applied for the logarithm time of the physical property of used insulation material.

CHAPTER THREE: RESEARCH METHODOLOGY

3.1 General

Various thermal models are being used for the estimating winding hot spot temperature character. So, lots of equipment are used for measurements of temperature inside and outside of the transformers. These actuators used for several tasks like detecting for the loss in cooling system and alarm system with trip function helps the operator and engineers for identifying the insulation life and loss of devices. The real time remote system for temperature monitoring and contact resistance for temperature of circuit breaker and connection points will provide system for automation. The methodology follows the IEC and IEEE standards C57.91 equations for thermal modelling.

3.2 Methodology

Several methods and models are used to calculate the thermal characteristics of the power and distribution transformer. The most common model used in the calculation relevant to transformer is IEEE standard C57.91. The methods and model deals with the different loading of transformer and the thermal estimation of oil immersed type transformers where the thermal properties have been used such as bottom oil raise, top oil raise and the average winding temperature for calculating the loss of life. The methods and model is unbiased understanding the fact where overall temperature rise in the transformer is due to the losses increased by increasing in the current by loading of transformer (IEEE, 2012). In the model, the upper limit of ambient temperature for the transformer is considered as 40⁰ Celsius and the average winding temperature is limited to 30⁰ Celsius. Similarly, the maximal value for winding hot spot temperature must not cross 110⁰ Celsius and the average winding temperature must be less than 65⁰ Celsius.

The factor for acceleration of aging is defined as the rate at which transformer insulation aging for a given hot spot temperature compared with the aging rate of transformer at a reference hot spot temperature. The point of reference for hot spot temperature is 110⁰ Celsius whereas for average winding temperature raise of 65⁰ Celsius and 95⁰ Celsius for 55⁰ Celsius winding temperature rise of the transformer. Percentage for life loss is defined as the overall equivalent aging at the point of reference hot spot temperature over the time divided by the total life of insulation at the reference hot spot temperature.

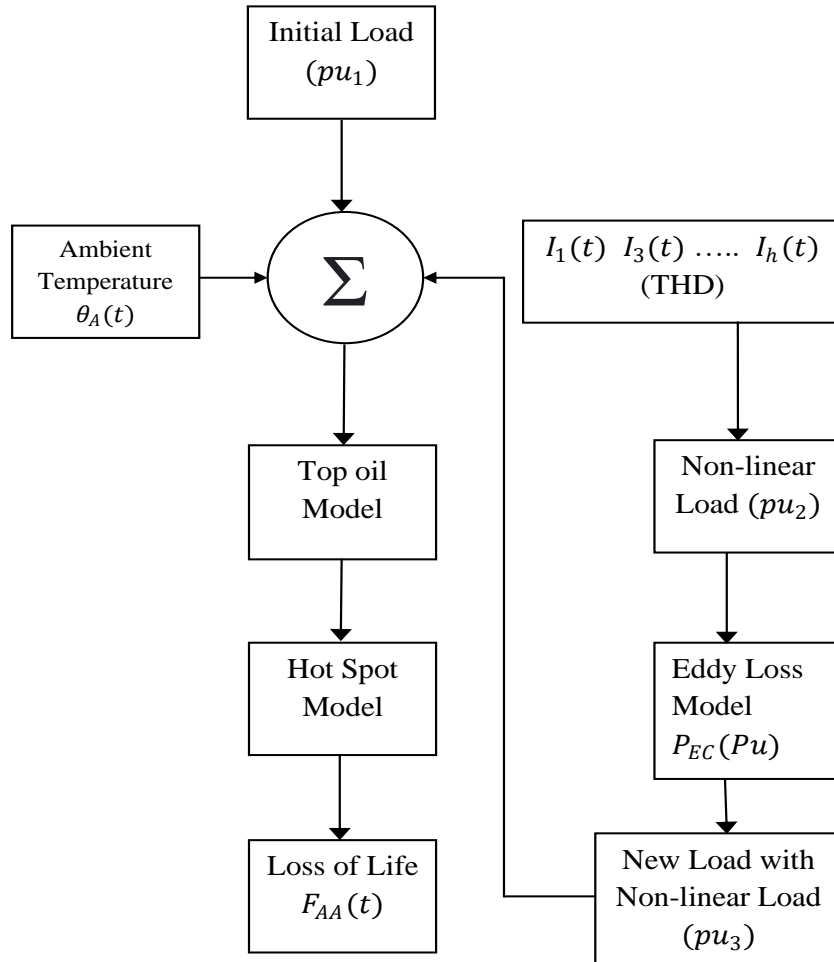

Figure 3.1 Simplified diagram for HST with loss of life

The Figure 3.1 shows all the step-to-step procedure for calculating the loss of life in the transformer by insertion of non-linear load to existing load of Lainchaur substation transformer. Real time data has been taken form lainchaur substation transformer of 22.5 MVA, 66/11 kV system having tap position at 15 number to acquire the daily load of winter and summer seasons along with average annual load in the time interval of hourly loading. Lainchaur Substation located at Lainchaur, Kathmandu feeds power to Keshar Mahal, Samakushi, Lazimpat, Gairidhara, Kingsway, Thamel, Royal Palace and K2 switching station. In this study the transformer used has a 20 year of life time based on the IEEE standards where average ambient temperature for winter season was 6°C and for summer it was 24°C along with 32°C also considered for average annual load. The other required parameter of transformer for IEEE standards simulation was taken from name plate of transformer.

The pu_1 loading of 22.5 MVA transformer in summer and winter seasons with ambient temperature is taken. The non-linear load pu_2 containing THD is inserted into the model in order to calculate total load pu_3 including winding eddy current losses. Therefore, overall load the sum of pu_1 and pu_3 is taken for top oil and hot spot model to calculate final winding temperature of hot spot. Loss of life factor is being calculated by the using aging acceleration factor $F_{AA}(t)$ at every hour which is the function of hot spot model.

3.2.1 Top oil transformer temperature model

The methods and model for overall increase in the temperature is due to temperature rise of top oil over the ambient temperature which shows an increase of losses in the transformer is due to its loading current of the device. The change in temperature of transformer is dependent within the overall thermal time constant. The mass of core, coils, and oil are the factors that is dependent upon the heat capacity of the transformer and also the rate at which heat is transferred out of transformer. So, temperature change is a function of time which has been modeled as exponential response of first-order that change from the initial state temperature to its final state of temperature is in the equation (3.1) (Gouda et al., 2012).

$$\Delta\theta_{TOil} = [\Delta\theta_{TO,u} - \Delta\theta_{TO,i}] \left[1 - e^{-\frac{t}{T_{TO}}} \right] + \Delta\theta_{TO,i} \quad (3.1)$$

Where, $\Delta\theta_{TO,i}$ represents initial temperature rise, $\Delta\theta_{TO,u}$ represents final temperature rise, T_{TO} represents the top oil time constant also t is time refers to change of time in loading and $\Delta\theta_{TOil}$ gives temperature rise of top oil over the ambient temperature value. Equation (3.1) is the first-order differential equation solution.

$$T_{TO} \frac{d\theta_{TOil}}{dt} + \theta_{TO,u} = \theta_{TO,i} \quad (3.2)$$

From IEEE standards, the final state of temperature rise is dependent on the existing load of transformer and obtained by the equation (3.3) (IEEE, 2012):

$$\Delta\theta_{TO,u} = \Delta\theta_{TO,R} \left[\frac{K_u^2 R + 1}{R + 1} \right]^n \quad (3.3)$$

Where, $\Delta\theta_{TO,u}$ gives the rated load temperature for top oil rise over the ambient temperature. R gives ratio of full load losses to no-load loss. Also, K represents the ratio of the particular load to full load where, $K = \frac{I}{I_{rated}}$ and n is value of exponent which is dependent on method of cooling. It is recommended to use n = 0.8 value for natural air convection and n from 0.9 to 1.0 for air forced system of cooling for transformer. Equations (3.1) and (3.3) are the thermal model for the IEEE top oil rise temperature. The time constant of the top oil at particular load is given by equation (3.4) (IEEE, 2012):

Table 3.1 Components used for temperature equation (IEEE, 2012)

Types of Cooling System	m	n
ONAN	0.8	0.8
ONAF	0.8	0.9
Non-directed OFAN or OFWF	0.8	0.9
Directed ODAF or ODWF	1.0	1.0

$$T_{TO} = \frac{C_{th-oil} \times \Delta\theta_{TO,R}}{q_{tot,rated}} \quad (3.4)$$

Where, T_{TO} represents the rated top oil time constant taken in hours, $\Delta\theta_{TO,R}$ gives the rated rise in top oil temperature, $q_{tot,rated}$ measured in watts (W) gives total losses, which is load at rated and the thermal capacitance represented as C_{th-oil} for the transformer oil (Watt-hours/ °C). Finally, for thermal capacitance of the transformer oil can be obtain from the equations (3.5) (Gouda et al., 2012).

$$C_{th-oil} = 0.48 \times M_{oil} \quad (3.5)$$

M_{oil} represents the weight of oil on the transformer measured in kilograms (kg). The equation is on the basis of heat run tests which is intrinsically taken into consideration with the impact in the metallic parts which is also recommended to use only when the information for fluid mass of transformer is known.

3.2.2 Hot spot temperature model

By increase in transformer losses because of loading is the effect of current increase which will increase the temperature of oil and the winding of transformer (IEEE, 2012). The transformer temperature state change from initial state to final state of the winding hot spot temperature rise is the exponential response of first order equation, calculated as.

$$\Delta\theta_H = [\Delta\theta_{Hu} - \Delta\theta_{Hi}] \left[1 - e^{-\frac{t}{T_H}} \right] + \Delta\theta_{Hi} \quad (3.6)$$

Where, $\Delta\theta_{Hi}$ represents initial temperature rise, $\Delta\theta_{Hu}$ represents final temperature rise, T_H represents transformer hot spot time constant also t is referred time to change in loading of transformer and $\Delta\theta_H$ gives winding temperature for hot spot rise. The first-order differential equation solution represents equation (3.6).

$$T_h \frac{d\theta_h}{dt} + \theta_h = \theta_{hu} \quad (3.7)$$

$$\Delta\theta_{Hu} = \Delta\theta_{H,R} [K_u]^{2m} \quad (3.8)$$

Where, $\Delta\theta_{H,R}$ gives rated hot spot temperature rise and m used for exponent value depending to the methods of cooling. Also, hot spot time constant of transformer winding, is calculated as in equation (3.9) (IEEE, 2012):

$$T_H = 2.75 \times \frac{\Delta\theta_{H,R}}{(1 + P_e) \times S^2} \quad (3.9)$$

Where, T_H represents the time constant of winding for rated load measured in minutes; P_e gives relative winding eddy losses of transformer; S gives value for current density measured in A/mm² for rated loading of transformer.

Finally, by the addition of the ambient temperature with rise in top oil temperature and the rise in hot spot temperature of transformer is calculated in equation (3.10).

$$\theta_H = \theta_A + \Delta\theta_H + \Delta\theta_{Toil} \quad (3.10)$$

Where, θ_A represents ambient temperature and θ_H represents temperature of hot spot.

3.2.3 Power (Loss) due to non-linear load model

For the transformer having rated current greater than 1000A, the eddy current losses (power) in pu are given by equations (M. B.B. Sharifian et al., 2003) (3.11) and (3.12) which is required for equivalent power loss of transformer during non-linear loads.

$$P_{EC}(Pu) = \frac{2.8P_{EC-R}}{3I_2^2 R_L} \quad (3.11)$$

Where, P_{EC-R} is pu winding eddy current losses at rated load and the location of hot spot. The I²R loss for the rated load is 1 pu in the assumption that all of the stray losses are being equal to winding eddy current losses of the transformer.

$$I_{max}(pu) = \left[\frac{1 + P_{EC-R}(pu)}{1 + (K)P_{EC-R}(pu)} \right]^{1/2} \quad (3.12)$$

Where, K is factor which value is equal to one during rms current for the load equals to transformer rated current.

3.2.4 Simulation of Transformer Loss of life model

At each instant of time frame the temperature of hot spot is the result of sum of three components ambient θ_A , top oil rise $\Delta\theta_{Toil}$ and hot spot rise temperature $\Delta\theta_H$ represented by equation (3.10). Additional heat generated $P_{EC}(Pu)$ by harmonics loads is given by equation (3.11) and (3.12). Finally, for the loss of life factor it is calculated by using aging acceleration factor $F_{AA}(t)$ at every hour which is the function of hot spot model and given by equation (3.13).

$$F_{AA} = \exp \left[\frac{15000}{383} - \frac{15000}{\theta_H + 273} \right] \quad (3.13)$$

The model equations are being solved by the use of MATLAB Software to obtain top oil and hot spot temperature model along with equation (3.13) is utilized to determine loss of life of the transformer by harmonic loading.

CHAPTER FOUR: RESULTS AND DISCUSSION

4.1 General

In previous chapter, regarding the modeling of the transformer using real data available from Lainchaur Substation is discussed. The real data of weather and load are being used to calculate the winding hot spot temperature for 22.5 MVA (Lainchaur) transformer on the basis of IEEE standard C57.91. Different percentage of loading due to different Feeders has been considered for the calculation to study the effect due to insertion of non-linear load on the power transformer nominal insulation life and the aging acceleration factor.

4.2 Transformer Parameter and Load Profile

In this study, 22.5 MVA 66/11 kV, ONAF power transformer of Lainchaur Substation is considered. The transformer rated parameters, input of model parameter and the loss of the transformer are given in Table 4.1.

Table 4.1 Rated thermal parameter of 22.5 MVA 66/11 KV transformer with losses

Parameters	Specification
Rated Primary Voltage(kV)	66
Rated Secondary Voltage(kV)	11
Rated Primary Current(A)	218.69
Rated Secondary Current (A)	1180.9
Oil Temperature Alarm($^{\circ}$ C)	85
Hot spot temperature alarm($^{\circ}$ C)	95
Hot spot temperature Trip($^{\circ}$ C)	105
Oil temperature Trip ($^{\circ}$ C)	95
Rated Top oil raise over ambient temperature ($^{\circ}$ C)	38.3
Rated Hot spot raise over top oil Raise temperature ($^{\circ}$ C)	23.5
Hot spot time constant (min)	7
Top oil time constant (min)	114
Exponent (n)	0.9
Exponent (m)	0.8
Total loss at rated	104700
Ratio of load loss to no load loss	5

In order to determine the winding hot spot temperature, the aging acceleration factor with loss of life from nominal life and sizing of rated capacity the load profile corresponding to Lainchaur Substation transformer is taken. The MATLAB software program has been used in simulation for input loading, ambient temperature and

required transformers data to obtain the winding hot spot temperature and temperature of top oil of the transformer. Different percentage Loading of Feeders with nonlinear load has been used during a 24 hours cycle. Results and required calculation are on the basis of IEEE standard C57.91 for winter and summer season of loading including different percentage of nonlinear load injection in Feeders are presented. The results were then utilized for calculating the aging acceleration factor, transformers loss of life and final sizing of transformer.

In this study the power transformer used has a 20 year of life time based on the IEEE standards where average ambient temperature for winter season was 6°C and for summer it was 24°C along with 32°C for average annual load. The other required parameter of transformer for IEEE standards simulation was taken from name plate of transformer. In the study it is considered that for load factor equals to 1 the maximum loading will be 540MWh per day of energy. So, percentage of loading per day is considered in the analysis of result in both winter and summer seasons respectively. For the worst case, loading of peak hour was taken in order to calculate winding hot spot temperature and transformer loss of life. Non-linear loading has been added on the simulation model in order to determine the effect of harmonic loading on winding hot spot temperature and transformer loss of life from its normal life.

Table 4.2 Load Cycle of Transformer

Time (24 Hours)	Date: 2021-12-17		Date: 2021-07-01	
	Power (MW)		Power (MW)	
	Substation	Feeder	Substation	Feeder
01:00:00	6.5	1.5	3.6	1.4
02:00:00	6.5	1.5	3.6	1.4
03:00:00	6.5	1.5	3.6	1.4
04:00:00	6.5	1.5	3.6	1.4
05:00:00	6	1.8	4.2	1.4
06:00:00	8	2.3	5.5	1.5
07:00:00	10	3.2	6	1.9
08:00:00	11.5	3.7	6.2	1.9
09:00:00	13	4.3	7	2.1
10:00:00	13.7	5	7.8	2.4
11:00:00	14.7	5	7.8	2.4
12:00:00	12	4.7	7.8	2.4
13:00:00	13	4.2	7.8	2.4
14:00:00	13	4.2	7.8	2.5

15:00:00	12.5	4	7.8	2.5
16:00:00	12.5	4.1	7.8	2.5
17:00:00	13	4.1	7.6	2.4
18:00:00	13.5	4.5	7	2.2
19:00:00	13.5	4.4	7	2.2
20:00:00	12	2.8	7	2.2
21:00:00	12	4.1	6.5	2
22:00:00	10.5	3.5	5.8	1.8
23:00:00	10	3	5.5	1.7
00:00:00	7.8	2.4	5	1.6

4.3 Case 1: Results of Power Transformer for Winter Season

In this study, the daily load curve and the ambient temperature of substation power transformer were taken at the interval of every hour. Then, the peak load is determined from the daily load curve. Also, the percentage of non-linear loads were inserted in the simulation model to calculate winding hot spot temperature along with the aging acceleration factor.

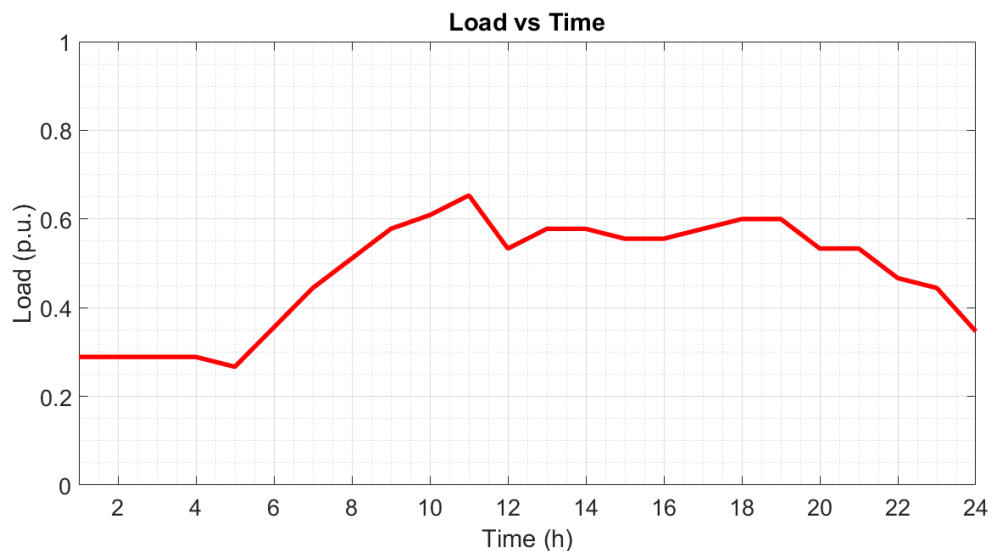

Figure 4.1 Daily Load Curve for Winter Season

In the Figure 4.1 daily load curve reached peak demand at 11 AM which is 0.65 pu loading of transformer. At the time ambient temperature was 6°C recorded at peak hour. For average loading it was around 258 MWh per day of energy. The average loading was near about 0.47 pu.

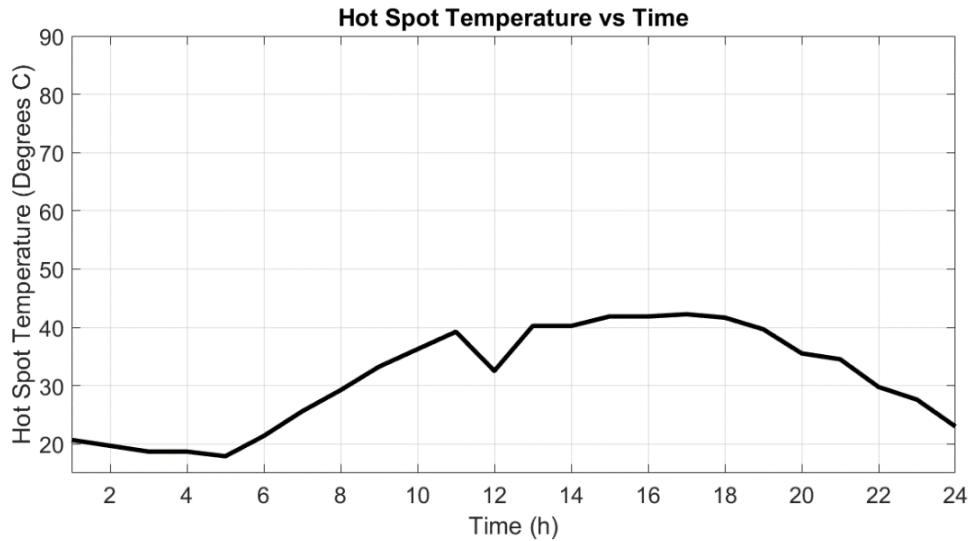

Figure 4.2 Cumulative Hot spot Temperature as per Base Load Condition of Power Transformer

In this case, at peak load the hot spot temperature of the transformer was 39.2°C given by IEEE standards model. The Figure 4.2 shows the hot spot temperature of transformer at base load condition at recorded ambient temperature. In hot spot temperature versus time graph the hot spot temperature is rising after 12 PM sharply because of rise in ambient temperature from 7°C to 12°C even if pu loading is decreased. This shows that winding temperature of the hot spot is dependent towards ambient temperature too.

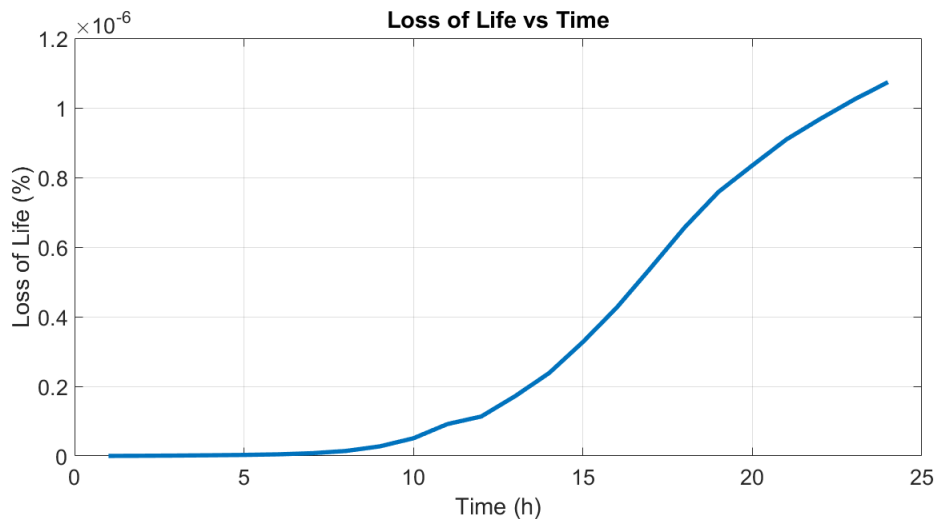

Figure 4.3 Loss of life curve for Winter of Power Transformer

The loss of life is shown in the Figure 4.3 it is known that there is rapid change and greater value of loss of life during peak temperature rise which occurs at 11 AM.

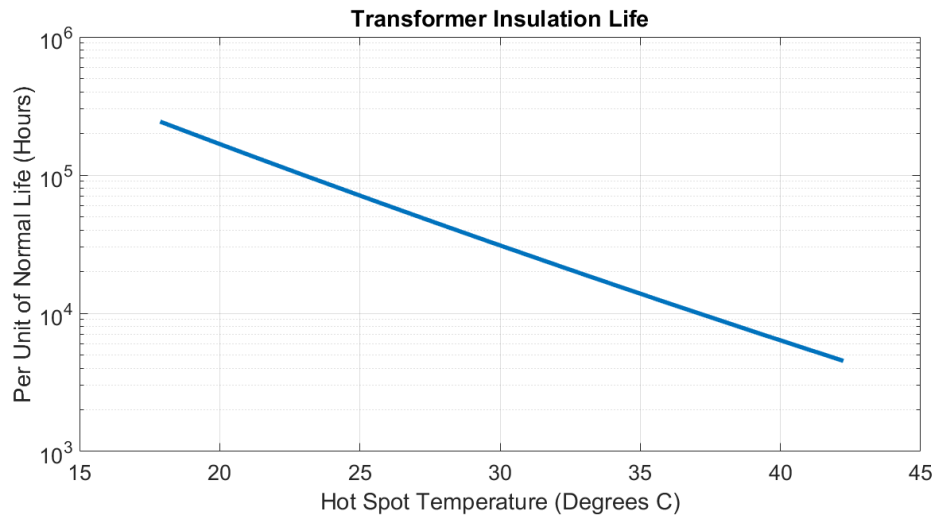

Figure 4.4 Per unit Life versus hot spot temperature curve for Winter of Power Transformer

In the Figure 4.4 it shows that below 20°C hot spot temperature the life of transformer is more than 20 years. As, winding hot spot temperature keeps on rising the per unit life of transformer will decrease.

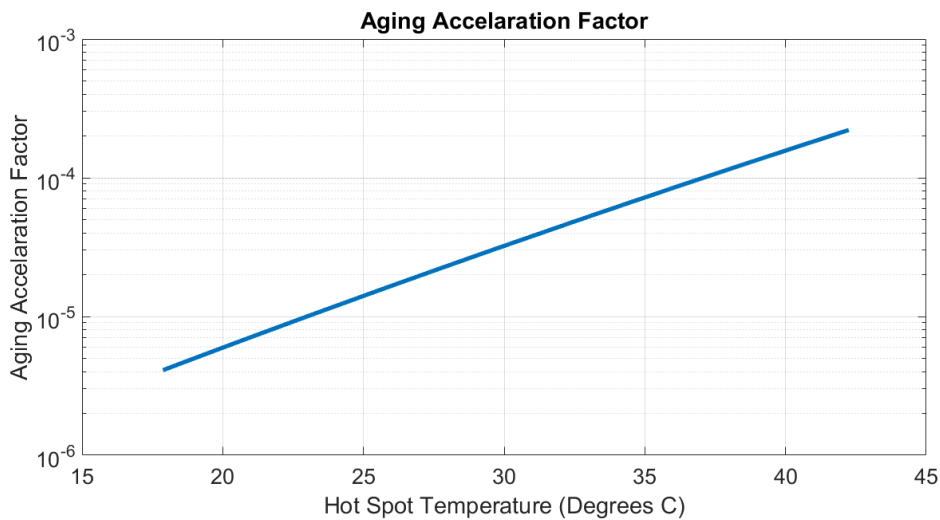

Figure 4.5 Aging acceleration factor curve for Winter of Power Transformer

From Figure 4.5 it indicates that higher the winding hot spot temperature will lower the life of transformer. F_{AA} is a function of the winding hot spot temperature in which hot spot temperature will occurs a change in F_{AA} . As per IEEE standard C57.91, if F_{AA} value is greater than 1 it indicates that HST exceeds reference temperature set by the standard 110⁰ Celsius. In winter case, HST has values between 20.01⁰C to 45.18⁰C and

F_{AA} changes between 0.00000141 to 0.000221. This helps to show F_{AA} is in relation with winding hot spot temperature based on the case of winter.

4.4 Case 2: Results of Power Transformer for Summer Season

The load curve presented in Figure 4.6 shows low load at starting and increases during morning time.

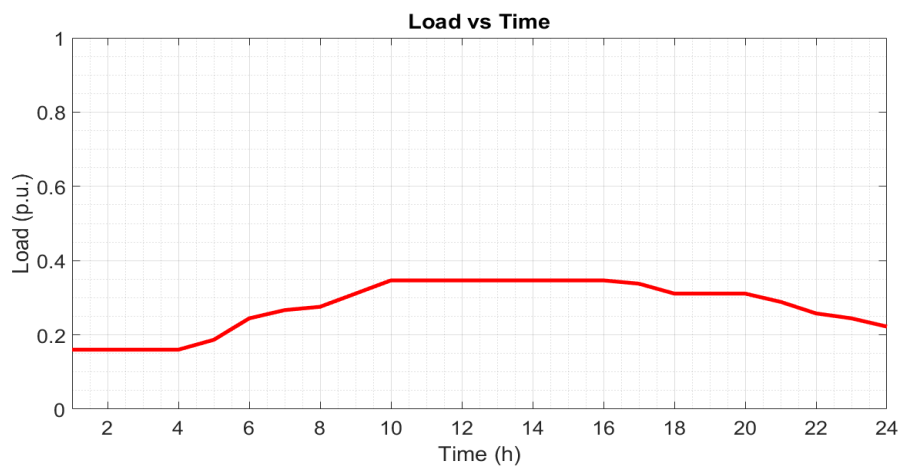

Figure 4.6 Load curve for Summer of Power Transformer

The loads have constant loading during daytime and rapid rise during 8 AM to 10 AM. The load curve shows maximum load of 0.346 pu and minimum load of 0.16 pu and the peak load occurs at day time. At the time ambient temperature was 24°C recorded at peak time. For, average loading it was around 150 MW hour per day of energy. The load varies dynamically at every instant of time.

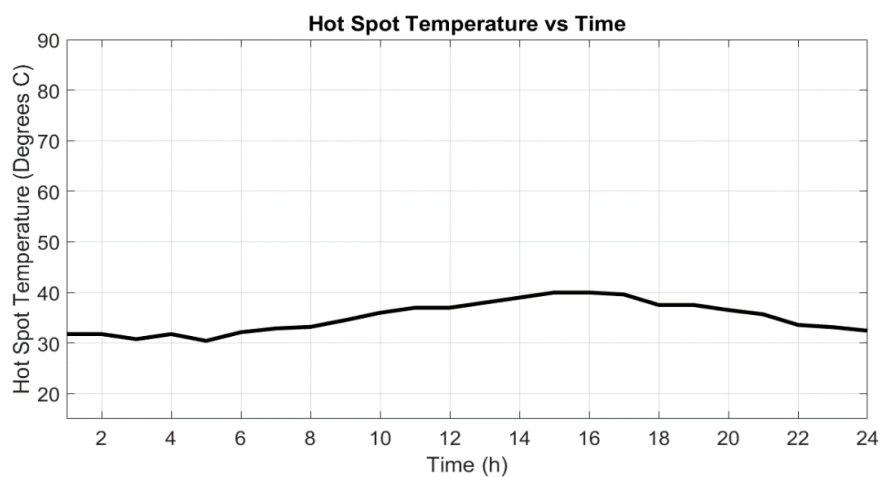

Figure 4.7 Cumulative Hot spot Temperature for Summer of Power Transformer

The curve in the Figure 4.7 shows the highest temperature in the transformer during the peak demand of normal condition reaches 39.9 Degree Celsius. The higher temperature will lead to decline in the insulation level and hence decreased the transformer life.

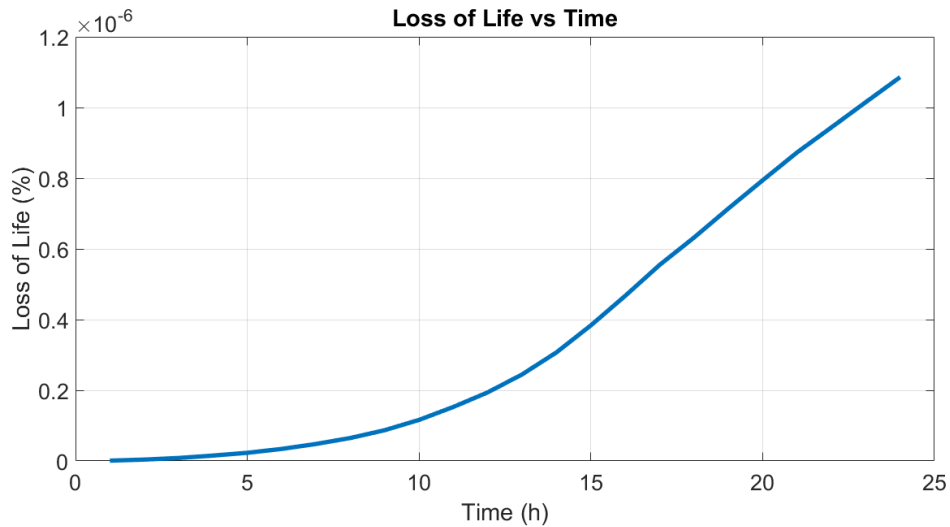

Figure 4.8 Loss of Life for Summer of Power Transformer

The loss of life is shown in Figure 4.8 and it is seen that there is gradual change and greater value of loss of life during peak temperature rise. The loss in life of transformer is lesser at lower temperature or small differential loading time but there is gradual increase in percentage loss of life as change in ambient temperature and loads.

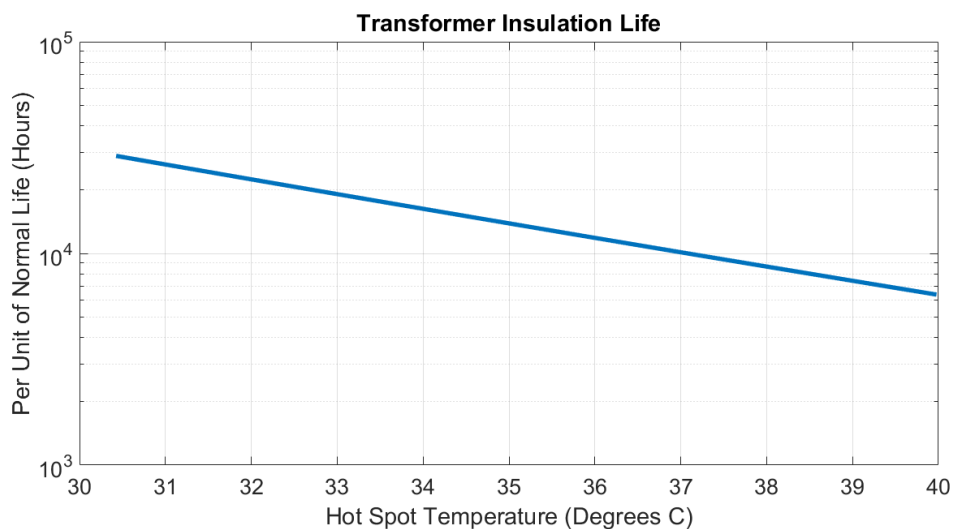

Figure 4.9 Per unit life versus hot spot temperature for Summer of Power Transformer

From Figure 4.9 it shows the higher the winding hot spot temperature will cause decline in the life of transformer. The per unit life at lower temperature is greater because the

slope of curve has greater value but at higher temperature, the slope is smaller so it shows the life becomes smaller during higher temperature.

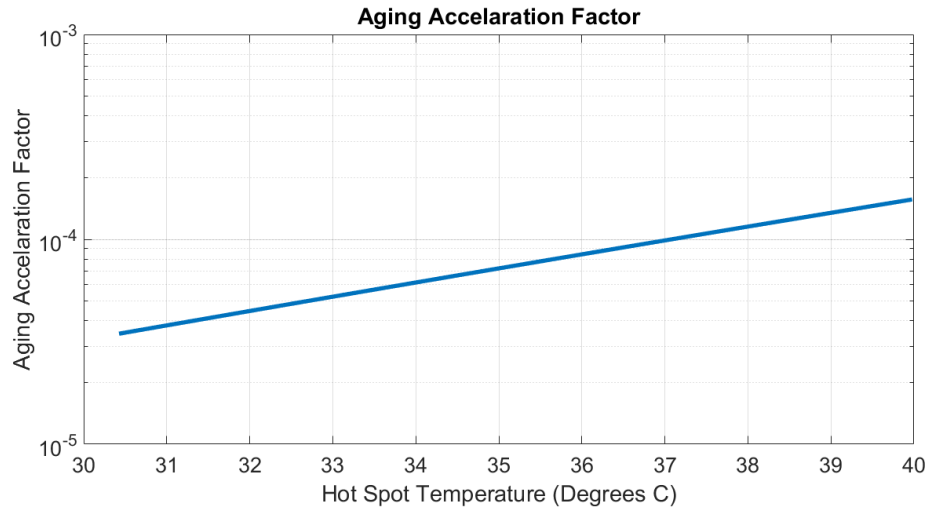

Figure 4.10 Aging acceleration factor curve for Summer of Power Transformer

In the Figure 4.10 ageing acceleration factor has minimum value of 0.0000046 pu and maximum value of 0.000157 pu. As, ambient temperature is increased it will directly increase the winding hot spot temperature also the aging factor for transformer will increased sharply. This shows the deterioration rate of insulation of transformer.

4.5 Case 3: Result for Average Annual Load of Power Transformer

The load curve presented in Figure 4.11 shows low load at starting and increases during morning time and flat curve over day time.

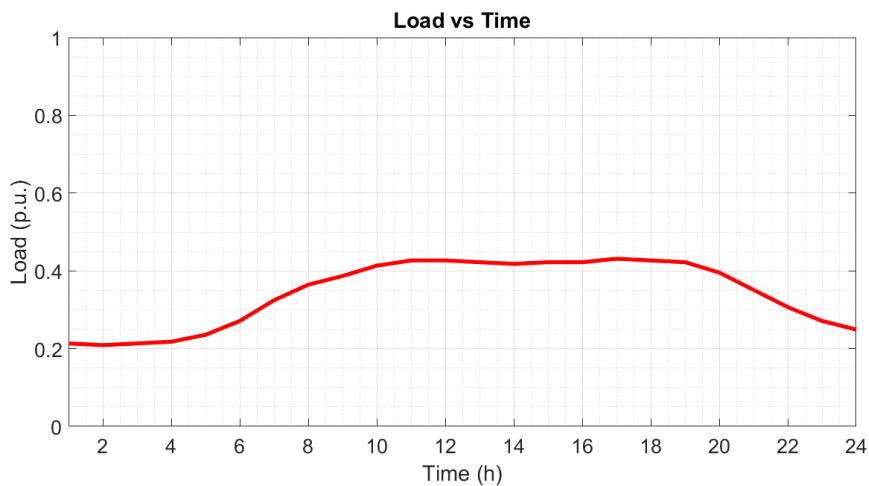

Figure 4.11 Average Annual load curve

The loads have constant loading during daytime and rapid rise during 6 AM to 10 AM. The load curve shows maximum load of 0.42 pu and minimum load of 0.20 pu and the peak load occurs at day time. At, the time ambient temperature was 32°C recorded at peak time. For, average loading it was around 185 MW hour per day of energy. The load varies dynamically at every instant of time.

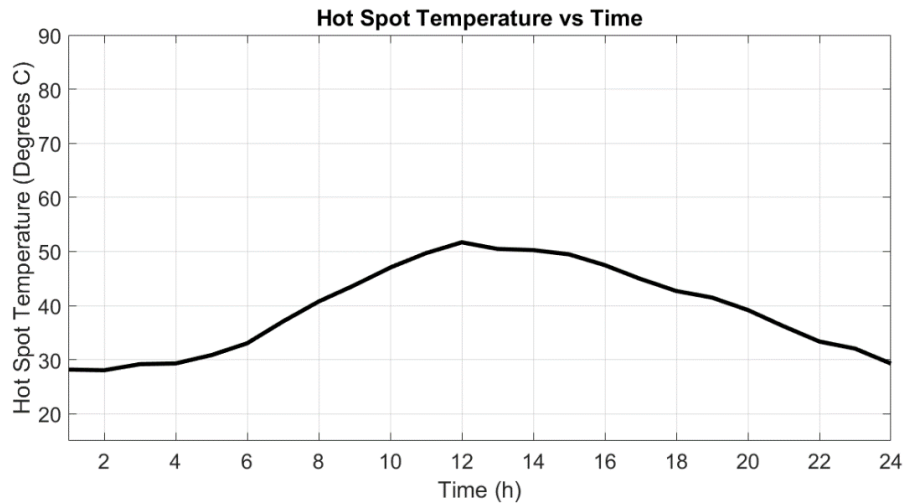

Figure 4.12 Cumulative Hot spot Temperature for Annual Average Load

The curve in the Figure 4.12 shows the highest temperature for the transformer during the peak demand towards normal condition reaches 51.6 Degree Celsius. At, peak there is only 0.42pu of load but the hot spot temperature is relatively higher due to ambient condition which was 32 °C. The higher winding temperature leads to the declination of the insulation level and hence decreased the life of transformer.

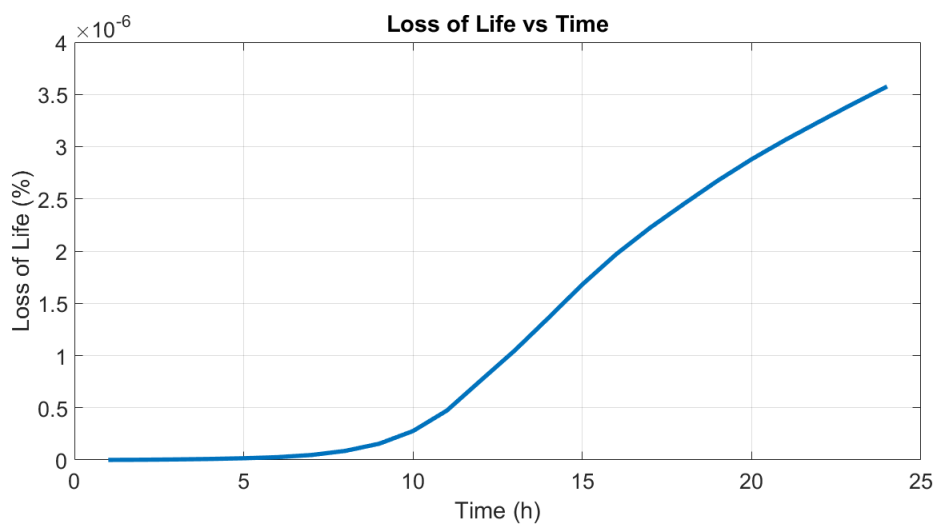

Figure 4.13 Loss of Life for Annual Average Load of Power Transformer

The loss of life is shown in Figure 4.13 and it is seen that there is gradual change and greater value of loss of life during peak temperature rise. The loss in life of transformer is less at lower temperature or small differential loading time but there is gradual increase in percentage loss of life as change in ambient temperature and loads.

4.6 Analysis of the Effects for Loading on Loss of Life

The case of winter and summer are analyzed in order to calculate the percentage of non-linear loading effect in loss of transformer nominal life by the significant values. As, ambient temperature and load of transformer keeps on changing every time. So, the worst-case scenario during peak hour and a whole day of 24 hours parameter has taken in the study to maintain reliability of the result.

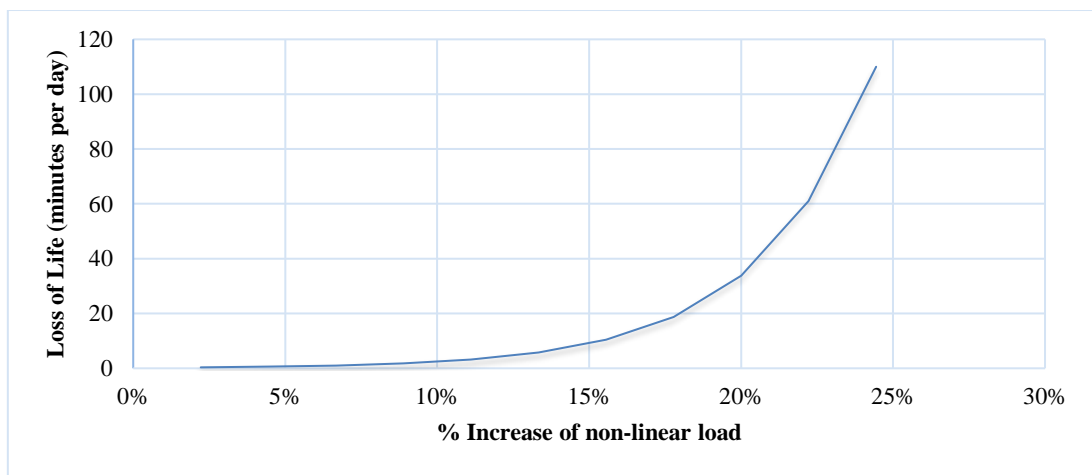

Figure 4.14 Effect of Non-linear Loading on Transformer Life (Winter)

The Figure 4.14 shows the exponential pattern for loss of life of transformer by insertion of non-linear load in the distribution system. The non-linear load is being inserted in simulation model by certain percentage of the transformer capacity. The hot spot temperature at the time of peak load is used in different percentage loading for calculation of the aging acceleration factor of transformer. So, the factor for aging acceleration is utilized for calculating loss of life per day if loading will be 24 hours for a day. It came to understand that after 15% of non-linear loading the loss of life will sharply increase. When the non-linear loads increase above 15% the harmonic current will also rise. This will add up eddy current loss to generated additional heat. Hence, hot spot temperature increases with increase in the value of aging acceleration factor and consequently for the loss of life of transformer is significantly increases.

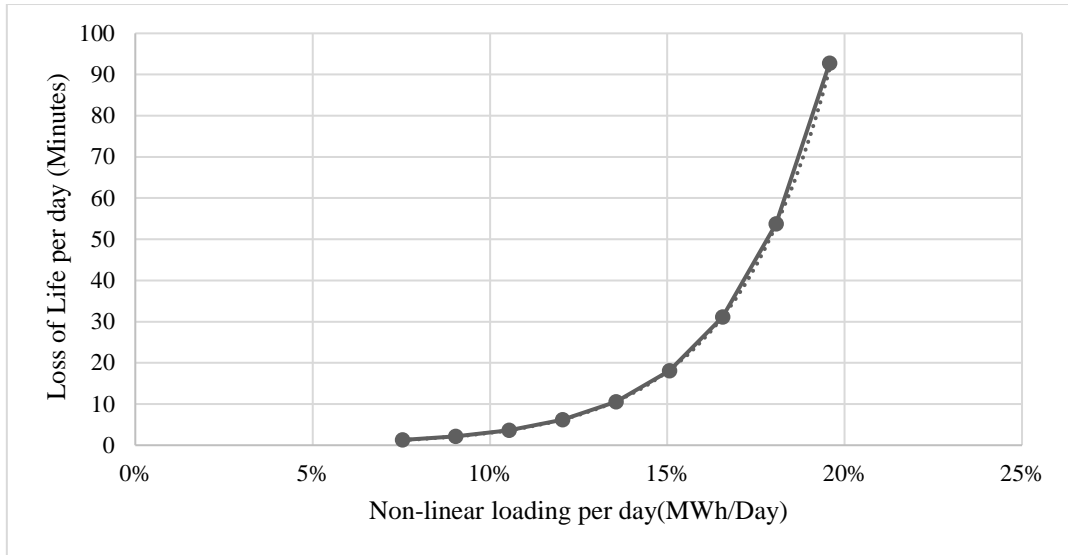

Figure 4.15 Effect of Non-linear Average Loading on Transformer Life (winter)

As, the ambient temperature is changed frequently and the winding hot spot temperature is also the function of the ambient temperature where transformer life is dependent on the temperature of hot spot. For better understanding towards loss of life of transformer, the cumulative aging acceleration factor of 24 hour is taken in model. This will give aging acceleration factor of every hour. Finally, the cumulative factor will provide the better information about transformer loss of life shown in Figure 4.15.

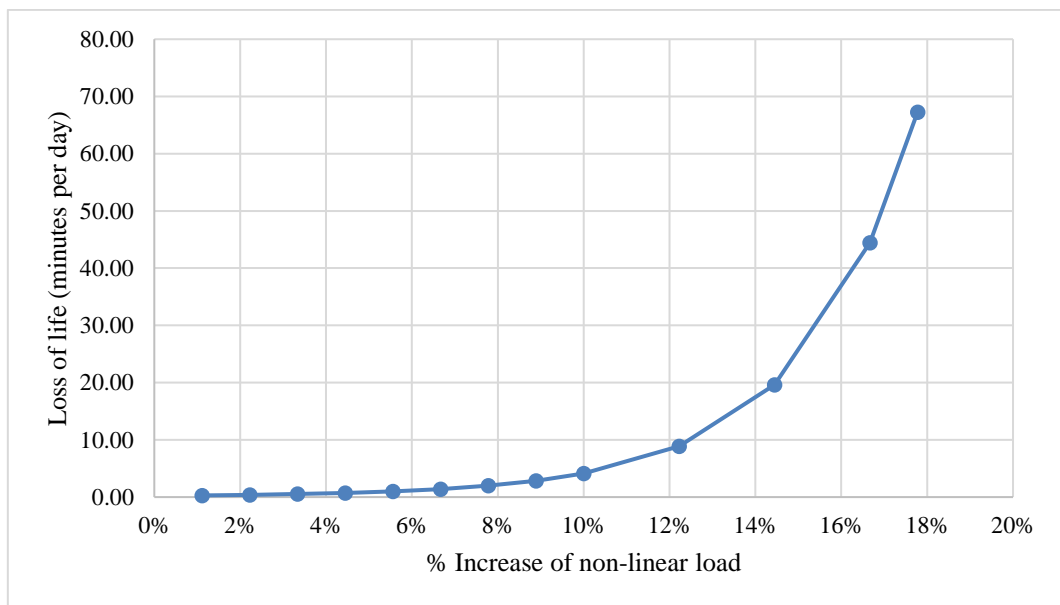

Figure 4.16 Effect of Non-linear Average Loading on Transformer Life (Summer)

As, comparing to winter condition of ambient temperature and pattern of load curve are different from summer but the from Figure 4.16 it is clear that for greater than 15% of non-linear loading there will be significant loss of life in transformer.

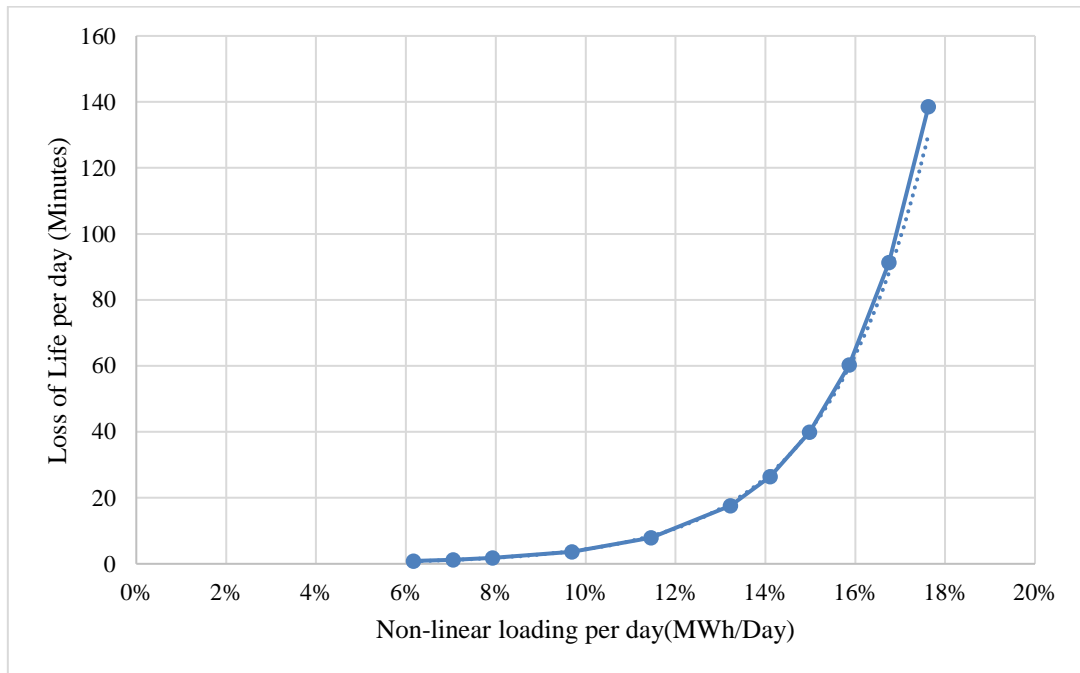

Figure 4.17 Effect of Non-linear Average Loading on Transformer Life (Summer)

From Figure 4.17 it shows the loss of life of transformer from cumulative 24 hours of age accelerating factor by insertion of non-linear loads. Even though the pu loading of transformer is less than in case of winter due to ambient temperature the hot spot temperature reaches like in case of winter.

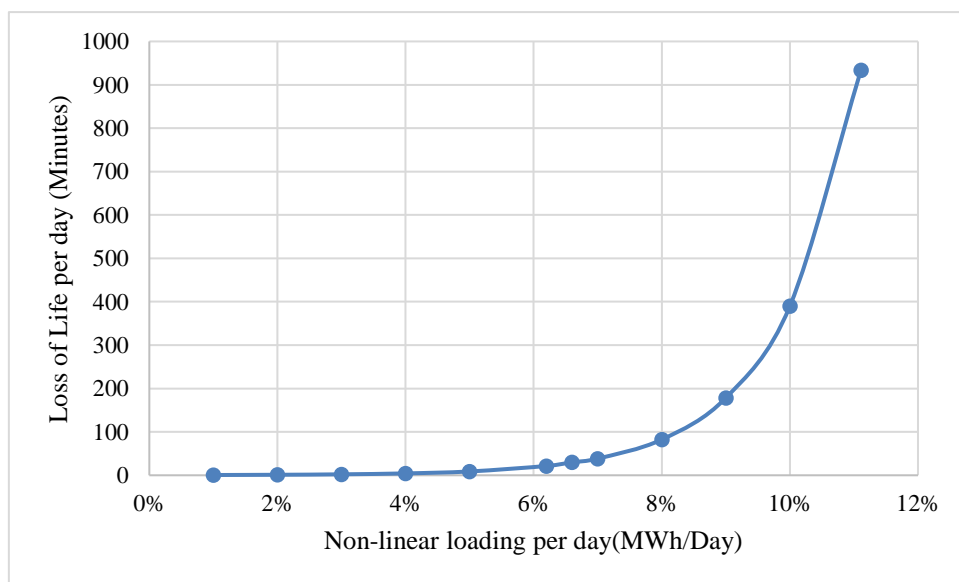

Figure 4.18 Effect of Non-linear Annual Average Loading on Transformer Life

The Figure 4.18 shows the exponential pattern for loss of life of transformer by insertion of non-linear load in the power transformer of substation during consideration of annual average load. The average ambient temperature of 32°C has been considered for worst case for transformer life loss. The hot spot temperature is used in different percentage loading for calculating the aging acceleration factor for the transformer. So, the factor for aging acceleration is used to calculate loss of life per day for the loading of 24 hours in a day. It came to understand that after 8% of non-linear loading the loss of life will sharply increase. When the non-linear loads increase above 8% the harmonic current will also rise. This will add up winding eddy current loss to generate additional heat. Hence, hot spot temperature increases with increase in the aging acceleration factor and consequently towards loss of life of transformer is significantly increases.

4.7 Analysis of Hotspot Temperature Towards Non-linear Load

We know that, when transformer is at 65% loading the hot spot temperature was 39.4°C at ambient temperature of 6°C. It shows that hot spot temperature rises by less than 1°C for every 1% load increase. But in case of harmonic loading the pattern is different from linear loads. The Figure 4.19 shows the hot spot temperature rise for non-linear loading.

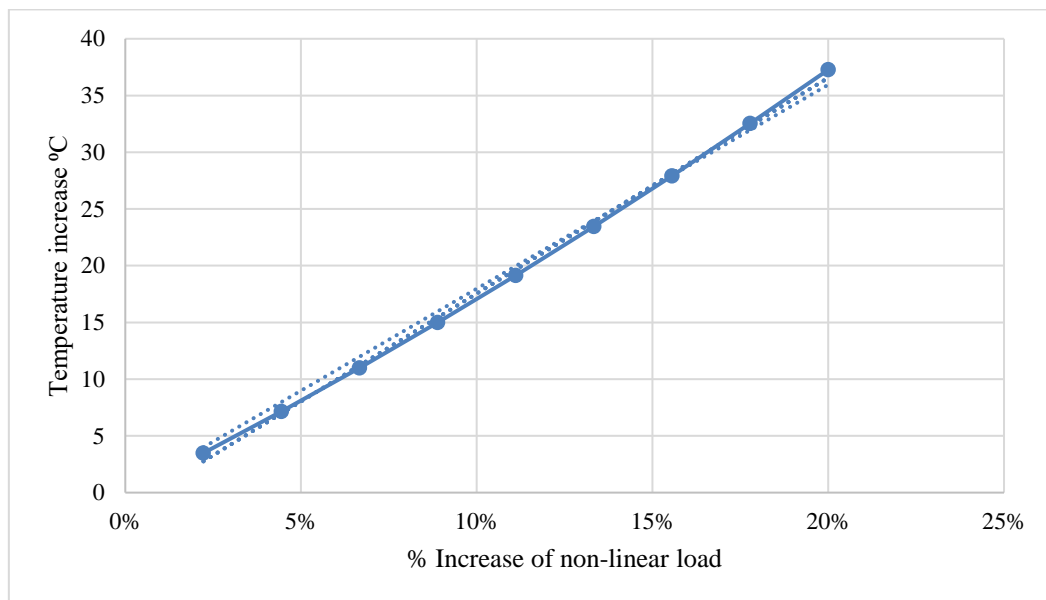

Figure 4.19 Effect on hot spot temperature rise due to harmonic loads (Winter)

It shows the increase in temperature of hot spot with the increase in percentage loading of non-linear load. It shows for every 1% increase in non-linear load the hot spot temperature rises by 2°C. As we know that the hot spot temperature can go up to 110°C

maximum after that the winding insulation of transformer will degrade sharply and leads to failure.

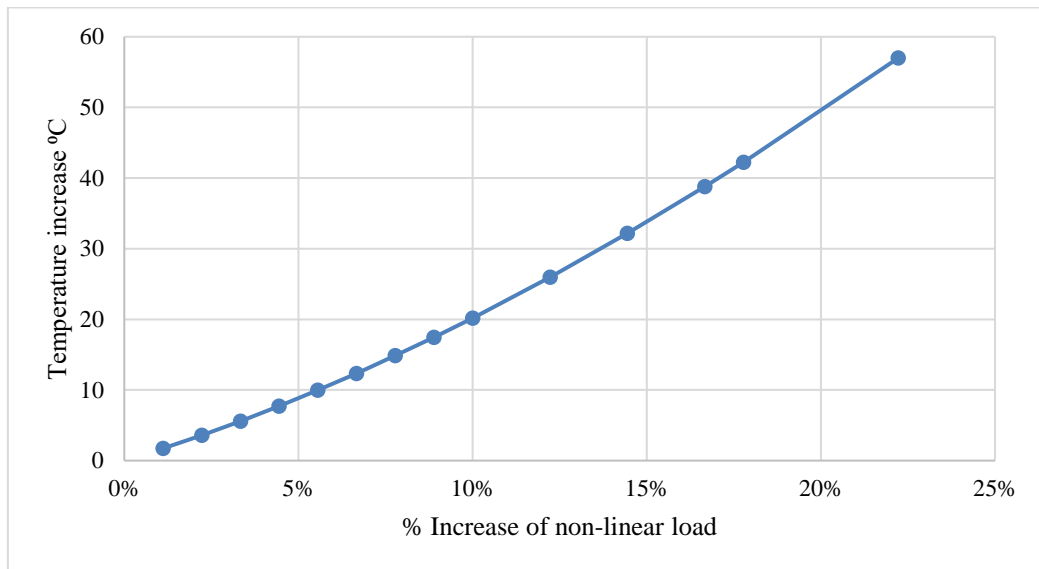

Figure 4.20 Effect on hot spot temperature rise towards harmonic loads (Summer)

The Figure 4.20 also shows the effect on hot spot temperature rise because of harmonic loads in case of summer. In this case up to 10% of harmonic loading for every percentage rise in non-linear load the hot spot temperature rises by 2°C maximum. But when the harmonic loading is increased above 13%, for every percentage loading of harmonic loading the hot spot temperature rises by greater than 2°C. In this case ambient temperature was already at 24°C. So, that increasing the harmonic loading the effect of ambient temperature also come into play.

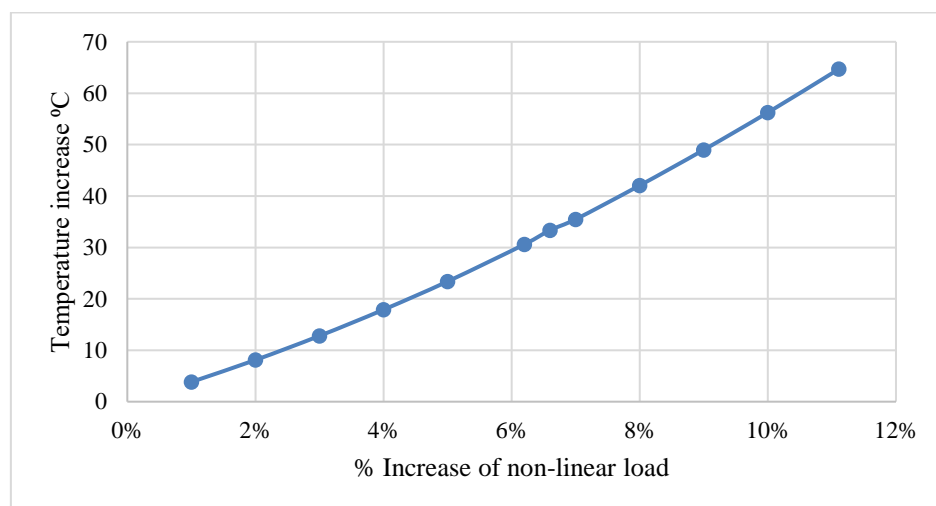

Figure 4.21 Effect on hot spot temperature rise due to harmonic loads for annual average load

The Figure 4.21 also shows the effect on hot spot temperature rise due to harmonic loads in case of annual average loading and worst summer ambient temperature. In this case up to 6% of harmonic loading for every percentage rise in non-linear load the hot spot temperature rises by 5°C maximum. But when the harmonic loading is increased above 8%, for every percentage non-linear loading the hot spot temperature rises greater than 5°C. In this case ambient temperature was already at 32°C. So, that increasing the harmonic loading the effect of ambient temperature also come into play.

4.8 Analysis of Non-Linear Loading Towards Sizing of Transformer

The rated capacity of the transformer is confined by the temperature of hot spot of the transformer at rated load. As, per design consideration and IEEE standards normally the maximum hot spot temperature for transformer is 110°C. If the load of transformer is increased then the heat is generated inside transformer due to currents flowing through windings along with eddy current loss. This will cause to increase in hot spot temperature. The Figure 4.22 shows the effect on sizing of transformer due to non-linear loads.

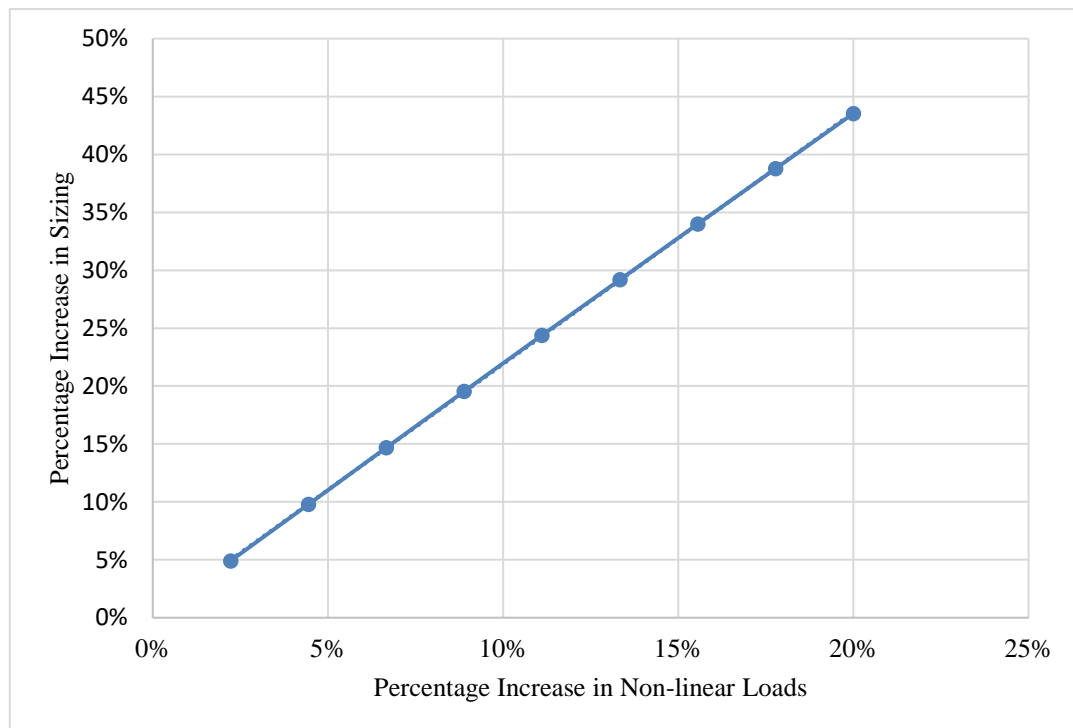

Figure 4.22 Effect on sizing of transformer in different non-linear loading condition (winter)

It shows the linear relationship for percentage increase of size of transformer as per percentage increase in harmonic loading. For, every 1 % increase in harmonic loading the size of transformer increases by 2 percentage. This is because the company standards transformer had already declared the value for rise in hot spot temperature for specific loading condition in case of linear load. But due to harmonic loading there will be extra losses in transformer due to eddy current loss which will increase the hot spot temperature before actual loading conditions. Finally, transformer will be in more loading than it was actually loaded. The ambient temperature come in to play when hot spot temperature is determined so, in sizing of transformer ambient temperature will affect.

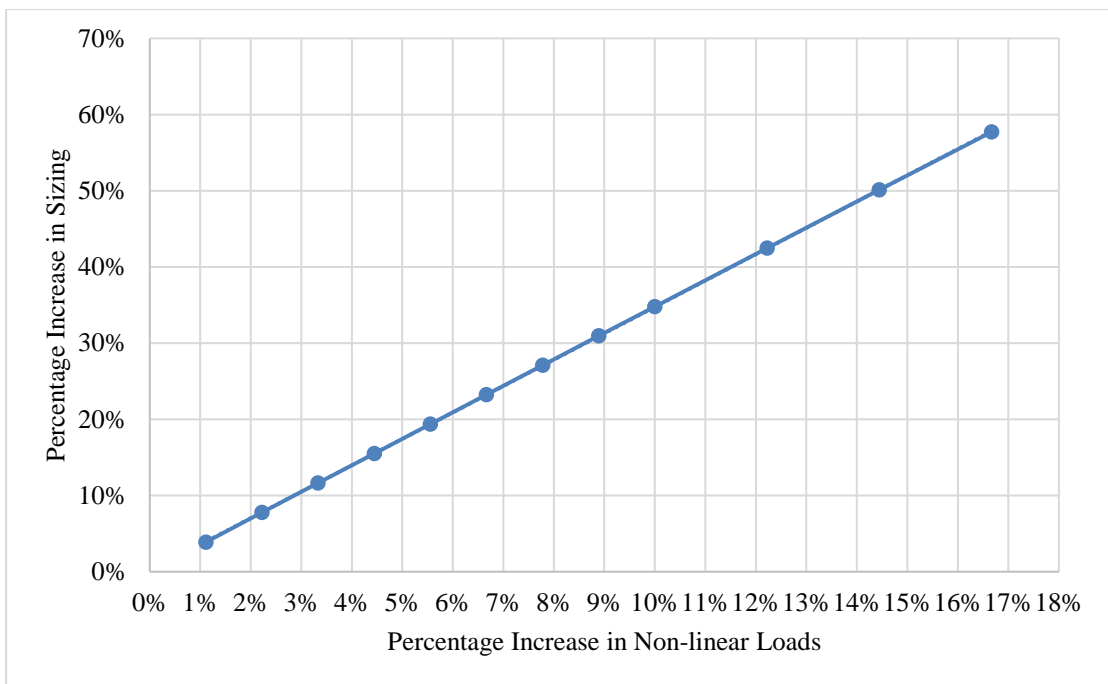

Figure 4.23 Effect on sizing of transformer in different non-linear loading condition (Summer)

The Figure 4.23 shows the effect of ambient temperature in sizing of transformer when non-linear load is inserted. It makes clear that for every 1% increase in harmonic loading the sizing of transformer will increase by 3%. The ambient temperature will come in to play in order to increase hot spot temperature along with winding eddy current losses.

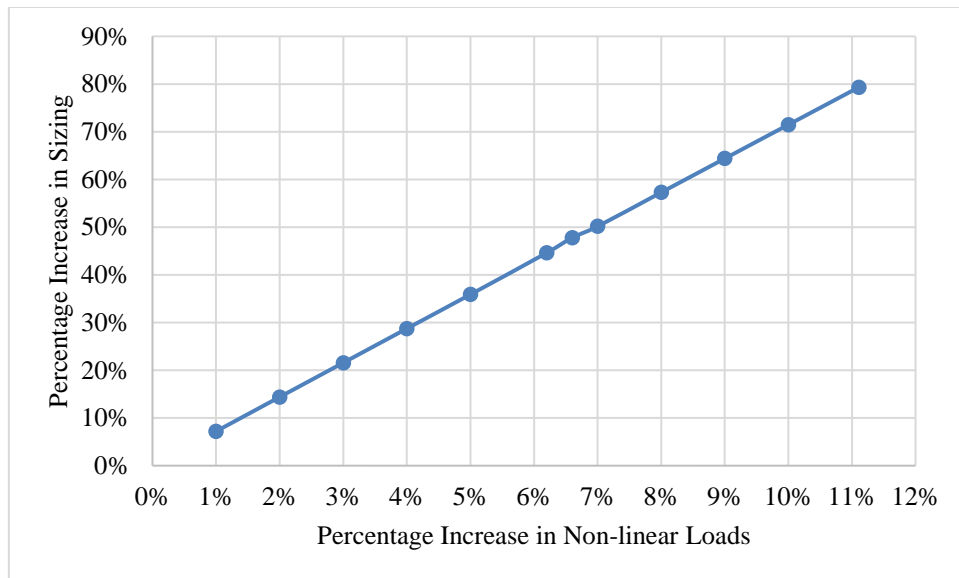

Figure 4.24 Effect on sizing of transformer in different non-linear loading condition for Annual Average Load

The Figure 4.24 shows the effect of ambient temperature in sizing of transformer when non-linear load is inserted by considering annual average load. It makes clear that in every 1% increase in harmonic loading regarding the capacity of transformer the sizing of transformer will increase by 5%. The ambient temperature will come in to play in order to increase hot spot temperature along with winding eddy current losses. Also, while considering annual average load with 32°C of average ambient temperature the transformer will not able to dissipate heat properly. Hence, the hot spot temperature will keep on rising continuously.

Ambient temperature is being consumed by the transformer due to which there is increase in temperature of the transformer which can be further increased by heating of the transformer because of continuous use. For validation of the study (Cazacu et al., 2018) demonstrated the aging acceleration factor of 1 at load factor of pu 0.646 by operating 250 kVA oil type transformer under nonlinear loads condition.

CHAPTER FIVE: CONCLUSIONS AND RECOMMENDATIONS

5.1 Conclusions

Following conclusions have been drawn from the study:

- The 22.5 MVA power transformer considered in the study shows the significant life reduction while non-linear loads are injected above 15% of the transformer capacity rating for both winter and summer season. But, for the worst case of annual average loading with 32°C of average ambient temperature significant life losses occur after crossing 8% of harmonic loading by showing exponential nature. It indicates higher the harmonic load of the transformer; nominal life will sharply decrease such that the transformer will be failure abruptly.
- After the injection of non-linear loads in the MATLAB simulation the harmonic load current of higher frequency will contribute for additional losses towards transformer windings along with core heating which will cause raise in temperature of transformer higher than the standard operating temperature. It is found that hot spot temperature increases by 2°C for every 1% increase of non-linear loading of rated capacity of transformer for winter seasons where as hot spot temperature increases by 2.7°C during summer.
- An increase in ambient temperature due to seasonal variation the hot spot winding temperature of transformer increases which will limit the operating capacity of the transformer and its capacity will be derated. The study concluded that the size of transformer is increased by 2% of its rated capacity for every 1% increase in nonlinear loading for winter season whereas sizing increased by 3% during summer.

5.2 Recommendations

Following recommendations have been drawn from the study:

- For reducing the significant effect in transformer life due to injection of non-linear loading application, derating of transformer capacity is recommended.
- Study area can be enlarged by considering the effect of unbalanced loading in transformer due to insertion of nonlinear load along with higher order current harmonics.

REFERENCES

- Abbas, Waseem, and Muhammad A. Saqib. 2007. "Effect of Nonlinear Load Distributions on Total Harmonic Distortion in a Power System." *2007 International Conference on Electrical Engineering, ICEE* 3–8.
- Abdul-Hameed, T. A., M. F. Akorede, Y. Abdulrahman, and O. M. Tijani. 2019. "An Investigation of the Harmonic Effects of Nonlinear Loads on Power Distribution Network." *Nigerian Journal of Technology* 38(2):401.
- Afifah, Sarah, Jannus Maurits Nainggolan, Gunawan Wibisono, and Chairul Hudaya. 2019. "Prediction of Power Transformers Lifetime Using Thermal Modeling Analysis." *2nd IEEE International Conference on Innovative Research and Development, ICIRD 2019*. doi: 10.1109/ICIRD47319.2019.9074661.
- Anon. 2002. *Terminology for Power and Distribution Transformers*. Vol. 2010.
- Anon. 2013. *Transformer Handbook*. Switzerland.
- Caicedo, Joaquín E., Andrés A. Romero, and Humberto C. Zini. 2017. "Evaluación de La Distorsión Armónica En Sistemas de Distribución Residencial: Revisión Literaria." *Ingenieria e Investigacion* 37(3):72–84. doi: 10.15446/ing.investig.v37n3.64913.
- Cazacu, Emil, Lucian Petrescu, and Valentin Ionita. 2017. "Derating of Power Distribution Transformers Serving Nonlinear Industrial Loads." *Proceedings - 2017 International Conference on Optimization of Electrical and Electronic Equipment, OPTIM 2017 and 2017 Intl Aegean Conference on Electrical Machines and Power Electronics, ACEMP 2017* 90–95. doi: 10.1109/OPTIM.2017.7974953.
- Chan, Ming Yin, Ken K. F. Lee, and Michael W. K. Fung. 2007. "A Case Study Survey of Harmonic Currents Generated from a Computer Centre in an Office Building." *Architectural Science Review* 50(3):274–80.
- Collin, Adam J., Charles E. Cresswell, and Saša Ž. Djokić. 2010. "Harmonic Cancellation of Modern Switch-Mode Power Supply Load." *ICHQP 2010 - 14th International Conference on Harmonics and Quality of Power*.
- Commission, International Electrotechnical. 2005. "IEC 60076-7:2005 - Loading

- Guide for Oil-Immersed Power Transformers.” doi: 10.1016/j.polymertesting.2008.08.004.
- Eduful, George, and Kingsford J. A. Atanga. 2017. “Evaluating the Performance of Harmonic Neutral Blocking Filter in ECG Electric Power Distribution System.” *Lecture Notes in Engineering and Computer Science* 2229:363–66.
- Feng, Dongyin, Zhongdong Wang, and Paul Jarman. 2014. “Evaluation of Power Transformers’ Effective Hot-Spot Factors by Thermal Modeling of Scrapped Units.” *IEEE Transaction on Power Delivery* 29(5):2077–85.
- Fuchs, Ewald F., Dingsheng Lin, and Jonas Martynaitis. 2006. “Measurement of Three-Phase Transformer Derating and Reactive Power Demand under Nonlinear Loading Conditions.” *IEEE Transactions on Power Delivery* 21(2):665–72. doi: 10.1109/TPWRD.2005.858744.
- Gruzs, Thomas M. 1990. “A Survey of Neutral Currents in Three-Phase Computer Power Systems.” *IEEE Transactions on Industry Applications* 26(4):719–25.
- Harlow, James H. 2012. *Electric Power Transformer Engineering*. 3rd Editio. edited by L. L. Grigsby. New York: CRC Press.
- Heathcote, Martin J. 2007. *The J & P Transformer Book*. 13th Editi. Burlington: Elseveier.
- Hurley, W. G., and W. H. Wölfle. 2013. *Transformers and Inductors for Power Electronics: Theory, Design and Applications*. United Kingdom: John Wiley & Sons ltd.
- IEEE. 2012. *IEEE Guide for Loading Mineral- Oil-Immersed Transformers and Step-Voltage Regulators*. Vol. 2011.
- Jalal, Thahirah Syed, Numan Rashid, and Ben Van Vliet. 2012. “Implementation of Dynamic Transformer Rating in a Distribution Network.” *2012 IEEE International Conference on Power System Technology, POWERCON 2012* 2–6. doi: 10.1109/PowerCon.2012.6401328.
- Jauregui-Rivera, Lida, and Daniel J. Tylavsky. 2008. “Acceptability of Four Transformer Top-Oil Thermal Models - Part II: Comparing Metrics.” *IEEE Transactions on Power Delivery* 23(2):866–72. doi:

10.1109/TPWRD.2007.905576.

- Kulkarni, S. V., and S. A. Khaparde. 2017. *Transformer Engineering Design, Technology, and Diagnostics*. 2nd Editio. New York: CRC Press.
- Lesieutre, B. C., W. H. Hagman, and J. L. Kirtley. 1997. "An Improved Transformer Top-Oil Temperature Model for Use in an Online Monitoring and Diagnostic System." *IEEE Power Engineering Review* 17(1):50. doi: 10.1109/MPER.1997.560690.
- Liew, Ah Choy. 1989. "Excessive Neutral Currents In Three-Phase Fluorescent Lighting Circuits." *IEEE Transactions on Industry Applications* 25(4):776–82.
- McBee, K. D., P. Rudraraju, and J. Chong. 2019. "Transformer Rating Due to High Penetrations of PV, EV Charging, and Energy Storage." *2019 IEEE Power and Energy Society Innovative Smart Grid Technologies Conference, ISGT 2019*.
- McLyman, T., and Colonel William. 2011. *Transformer and Inductor Design Handbook*. 4th ed. New York: CRC Press.
- Mohsenzadeh, Amin, Mohammad Heidari Kapourchali, Chengzong Pang, and Visvakumar Aravinthan. 2016. "Impact of Smart Home Management Strategies on Expected Lifetime of Transformer." *Proceedings of the IEEE Power Engineering Society Transmission and Distribution Conference 2016-July*.
- Peng, Fang Z. 2001. "Harmonic Sources and Filtering Approaches." (August).
- Perera, K. B. M. I., and Rohan Lucas. 2015. "By." (July).
- Rudnick, Hugh, Rodrigo Palma-Behnke, Andrea Rudnick, and Carlos Benavides. 2014. "Restless Waters: Fossil Fuel Emissions Conditioning a Reduction in Hydroelectric Resources in Chile." *IEEE Power and Energy Magazine* 12(5):50–60. doi: 10.1109/MPE.2014.2331897.
- Salvatierra, B., K. Coyago, D. Chacón, and Juan P. Inga. 2017. "Inverter Resonant Control by Modified SPWM and Trapezoidal Modulation for Induction Cooking." *2016 IEEE International Autumn Meeting on Power, Electronics and Computing, ROPEC 2016 (Ropec)*.
- Sharifian, M. B. Bannae, K. Banan Ali-abbasi, and S. S. Pourazar. n.d. "Study and Testing of Large Non-Linear Loads Effects on the Distribution Networks."

- Shrestha, Sadhana, and Timothy M. Hansen. 2016. "Distribution Feeder Impacts of Electric Vehicles Charging in an Integrated Traffic and Power Network." *NAPS 2016 - 48th North American Power Symposium, Proceedings* 0–5.
- Simonson, Edward. 1998. "Transformer Ratings and Transformer Life." *IEE Colloquium (Digest)* (510). doi: 10.1049/ic:19981011.
- Sönmez, Olus, and Guven Komurgoz. 2018. "Determination of Hot-Spot Temperature for ONAN Distribution Transformers with Dynamic Thermal Modelling." *2018 Condition Monitoring and Diagnosis, CMD 2018 - Proceedings*. doi: 10.1109/CMD.2018.8535752.
- Tan, Li, Hualong Li, Xiaohui Yan, Jun Tian, and Jiangtao Li. 2012. "An Improved Thermal Model for Power Transformers with Dynamic Loading." *Asia-Pacific Power and Energy Engineering Conference, APPEEC*. doi: 10.1109/APPEEC.2012.6307663.
- Tang, W. H., Q. H. Wu, and Z. J. Richardson. 2004. "A Simplified Transformer Thermal Model Based on Thermal-Electric Analogy." *IEEE Transactions on Power Delivery* 19(3):1112–19. doi: 10.1109/TPWRD.2003.822968.
- Turowski, Janusz, and Marek Turowski. 2014. *Engineering Electrodynamics*. New York: CRC Press.
- Tylavsky, Daniel J., Qing He, Gary A. McCulla, and James R. Hunt. 2000. "Sources of Error in Substation Distribution Transformer Dynamic Thermal Modeling." *IEEE Transactions on Power Delivery* 15(1):178–85. doi: 10.1109/61.847248.
- U.S. Department of Energy. 2013. *U.S. Energy Sector Vulnerabilities to Climate Change and Extreme Weather*.
- Vecchio, Robert M. Del, Poulin Bertrand, Pierre T. Feghali, Dilipkumar M. Shah, and Rajendra Ahuja. 2018. *Transformer Design Principles*. Third Edit. New York: CRC Press.
- Xu, Yijun, Yunshan Xu, Zimin Chen, Fei Peng, and Mohammed Beshir. 2015. "Harmonic Analysis of Electric Vehicle Loadings on Distribution System." *Proceedings - 2014 IEEE International Conference on Control Science and Systems Engineering, CCSSE 2014* 145–50.

- Yildirim, Deniz, and Ewald F. Fuchs. 2000. "Measured Transformer Derating and Comparison with Harmonic Loss Factor (FHL) Approach." *IEEE Transactions on Power Delivery* 15(1):186–91. doi: 10.1109/61.847249.
- Ziger, Igor, Bojan Trkulja, and Zeliko Stih. 2018. "Determination of Core Losses in Open-Core Power Voltage Transformers." *IEEE Access* 6:29426–35.

APPENDIX A: TEMPERATURE DATA

Time	Date:	Date:
Hours	2021-12-17	2021-07-01
	Temp(⁰ C)	Temp(⁰ C)
01:00:00	7	22
02:00:00	6	22
03:00:00	5	21
04:00:00	5	22
05:00:00	5	20
06:00:00	5	20
07:00:00	5	20
08:00:00	5	20
09:00:00	5	20
10:00:00	6	20
11:00:00	6	21
12:00:00	7	21
13:00:00	12	22
14:00:00	12	23
15:00:00	15	24
16:00:00	15	24
17:00:00	14	24
18:00:00	12	23
19:00:00	10	23
20:00:00	10	22
21:00:00	9	22
22:00:00	8	21
23:00:00	7	21
00:00:00	7	21

APPENDIX B: SLD OF LAINCHAUR SUBSTATION

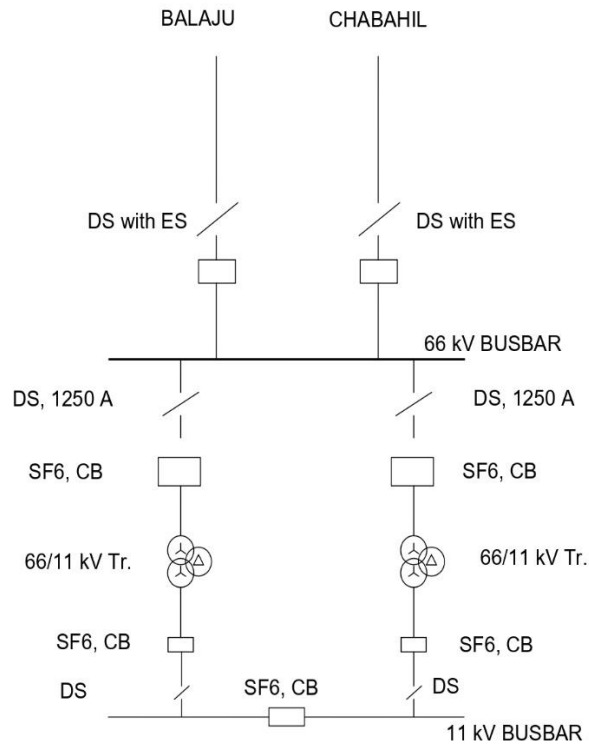

APPENDIX C: MATLAB CODE

Hot Spot temperature

```
function PUL_new=HOT_calc(P_loading)
    %%% Identifying the constants for the model
    t = 1:24;
    TOT_rated =38.3; % Initial Temperature Rise
    TOT_fl = 85; % Full-load Temperature Rise
    Tau = 24; % Time Constant for increase in temp
    R = 5; % Ratio of the load losses at full rated load to no-load loss
    n = 0.9; % Forced Cooling of Transformer
    Tau_Rated = ((5184*38.3)/104700); %Rated Time Constant for temp increase
    PF = 1;
    P_rated = PF*22.5e6; % Rated Power of transformer in MW
    V=11.00e3; % 11.00 KV
    I_Rated=1180.9; % Ampere
    P_t = P_loading;
    P_t=P_t*10^6;
    I=P_t/(sqrt(3)*PF*V);
    K_t= I/I_Rated;
    %save KT.mat K_t
    %K= P_t/P_rated
    % Calculation of initial TOT
    [~,c] =size(K_t);
    TOT_initial_t= zeros(1,c);
    TOT_initial_t_new= zeros(1,c);
    For i=1:c
    TOT_initial_t(1,i)= TOT_rated*((K_t(1,i)^2*R+1)/(R+1))^n;
    end
    for i=1:c
    if i ==1
    TOT_initial_t_new(1,1) =TOT_initial_t(1,1);
    else
    TOT_initial_t_new(1,i)=TOT_initial_t(1,i-1);
    end
    end
    % Calculation of ultimate TOT
    TOT_ult_t = TOT_rated * ((K_t.^2*R+1)/(R+1)).^n;
    % Calculation of Top Oil Temp of Transformer
```

```

Delta_TOT=((TOT_ult_t)-(TOT_initial_t_new(1,i)))*(1-exp(-(
(Tau/Tau_Rated)))+ TOT_initial_t_new (1,i);
%%%%%%%%%%%%%%%%%%%%%%%%%%%%%%%%%%%%%%%%%%%%%%%%%%%%%%%%%%%%%%%%%%%%%%%%
% HST_Int= 60; % Initial HotSpot Temp
HST_Rated= 23.5; % HST Temp for Rated-load
% HST_Int= 55; % Initial HotSpot Temp
% HST_Rated= 59; % Rated load HotSpot Temp
T_HST =7; % HotSpot Time Constant
m= 0.8; % Forced Cooling for transformer
Tau_H =2.75 *((HST_Rated)/(1+11350)*2.5^2); % Rated T C
%%%%%%%%%%%%%%%%%%%%%%%%%%%%%%%%%%%%%%%%%%%%%%%%%%%%%%%%%%%%%%%%%%%%%%%%
% Calculation of initial HST
HST_initial_t= zeros(1,c);
HST_initial_t_new= zeros(1,c);
for i=1:c
HST_initial_t(1,i)= HST_Rated *((K_t(1,i)^2*R+1)/(R+1))^n;
end
for i=1:c
if i == 1
HST_initial_t_new(1,1)= HST_initial_t(1,1);
else
HST_initial_t_new(1,i) = HST_initial_t(1,i-1);
end
end
% Calculation of ultimate HST
HST_ult_t= HST_Rated *(K_t.^(2*m));
% Calculation of Hot Spot Temp for Transformer
Delta_HST=(HST_ult_t-HST_initial_t_new)*(1-exp(-(Tau/Tau_H))
+HST_initial_t_new;
%%%%%%%%%%%%%%%%%%%%%%%%%%%%%%%%%%%%%%%%%%%%%%%%%%%%%%%%%%%%%%%%%%%%%%%%
% For Ambient Temp
% Ambient_Temp = [22 22 21 22 20 20 20 20 20 20 21 21
22 23 24 24 24 23 23 22 22 21 21 21]; %Summer
Ambient_Temp = [7 6 5 5 5 5 5 5 5 5 6 6 7 12
12 15 15 14 12 10 10 9 8 7 7]; %winter
% Ambient_Temp = [22 22 21 22 20 20 20 20 20 20 21 21
22 23 24 24 24 23 23 22 22 21 21 21]*1.25; %Summer
% Ambient_Temp = [17 17 18 18 19 20 22 24 26 28 30 32
31 31 30 28 25 23 22 21 20 19 19 17];%highest summer
%%%%%%%%%%%%%%%%%%%%%%%%%%%%%%%%%%%%%%%%%%%%%%%%%%%%%%%%%%%%%%%%%%%%%%%%
% The Cumulative Temp for Thermal Model
Cumulative_Temp = Ambient_Temp+Delta_HST+Delta_TOT;

```

```

%%%%%%%%%%%%%%%%%%%%%%%%%%%%%%%%%%%%%%%%%%%%%%%%%%%%%%%%%%%%%%%%%%%%%%%%
[~,c]=size(Cumulative_Temp);
Faa = zeros(1,c);
FAA_Cum = zeros(1,c);
Feqa = zeros(1,c);
LOL = zeros(1,c);
% Calculation for the Aging Acceleration Factor
for i=1:c
Faa(1,i) =(exp((15000/383)-(15000/(Cumulative_Temp(1,i)+273))));
end
[CT_sort,id] =sort(Cumulative_Temp, 'ascend');
% Sort for eigenvector
Faa_new =Faa(:,id);
% Calculation for Cumulative Aging Hours
for i=1:c
if i ==1
FAA_Cum(1,1) =Faa(1,1);
else
FAA_Cum(1,i)=FAA_Cum(1,i-1)+Faa(1,i);
end
end
% Calculation for the Equivalent Aging Factor
for i=1:c
Feqa(1,i)=FAA_Cum(1,i)/24;
end
% Calculation for the Percent Loss of Life
for i=1:c
LOL(1,i)=((Feqa(1,i)*(i)*100)/180000);
end
% Calculation for the Transformer Isolation Loss of Life
for i=1:c
PUL(1,i)=(9.80*(10^-18))*(exp((15000/(273+Cumulative_Temp(1,i)))));
end
[CT_sort,id]=sort(Cumulative_Temp, 'ascend');
% Sort of eigenvector
PUL_new=PUL(:,id);
%%%%%%%%%%%%%%%%%%%%%%%%%%%%%%%%%%%%%%%%%%%%%%%%%%%%%%%%%%%%%%%%%%%%%%%%
Faa(1,c)
FAA_Cum(1,c);
Feqa(1,c)

```

```

LOL(1,c)
PUL (1,c);
%% Graph plots
%%%%%%%%%%%%%%%%%%%%%%%%%%%%%%%%%%%%%%%%%%%%%%%%%%%%%%%%%%%%%%%%%%%%%%%%
figure
plot(t,K_t,'r','LineWidth',4);
hold on
grid on;
axis([1,24,0,1]);
xlabel ('Time (h)');
ylabel ('Load (p.u.)');
title ('Load vs Time');
grid minor
set (gca,'FontSize',20)
%%%%%%%%%%%%%%%%%%%%%%%%%%%%%%%%%%%%%%%%%%%%%%%%%%%%%%%%%%%%%%%%%%%%%%%%
figure
plot(t,Delta_TOT,'r','LineWidth',4);
% legend (Delta-TOT)
hold on
grid;
axis([1,24,8,60]);
xlabel ('Time (h)');
ylabel ('Top Oil Rise Temperature (Degree C)');
title ('Top Oil Temperature vs Time');
set(gca,'FontSize',20)
% %%%%%%%%%%%%%%%%%%%%%%%%%%%%%%%%%%%%%%%%%%%%%%%%%%%%%%%%%%%%%%%%%%%%%%%%%
figure
plot (t,Delta_HST,'b','LineWidth',4);
% legend (Delta-HST)
hold on
grid;
axis([1,24,2,40]);
xlabel ('Time (h)');
ylabel ('Hot Spot Rise Temperature (Degrees C)');
title ('Hot Spot Rise Temperature vs Time');
set (gca,'FontSize',20)
%%%%%%%%%%%%%%%%%%%%%%%%%%%%%%%%%%%%%%%%%%%%%%%%%%%%%%%%%%%%%%%%%%%%%%%%
figure
plot( t,Cumulative_Temp,'k','LineWidth',4);
% legend (Cumulative-Temp)

```

```

grid;
axis ([1,24,15,90]);
xlabel ('Time (h)');
ylabel ('Hot Spot Temperature (Degrees C)');
title ('Hot Spot Temperature vs Time');
set (gca, 'FontSize',20)
%%%%%%%%%%%%%%%%%%%%%%%%%%%%%%%%%%%%%%%%%%%%%%%%%%%%%%%%%%%%%%%%%%%%%%%%
figure
plot (t,LOL, 'LineWidth',4)
% legend (Loss of life)
grid;
xlabel ('Time (h)');
ylabel ('Loss of Life (%)');
title ('Loss of Life vs Time');
set (gca, 'FontSize',20)
%%%%%%%%%%%%%%%%%%%%%%%%%%%%%%%%%%%%%%%%%%%%%%%%%%%%%%%%%%%%%%%%%%%%%%%%
figure
semilogy (CT_sort,PUL_new, 'LineWidth',4)
% legend (Per Unit life)
grid;
xlabel ('Hot Spot Temperature (Degrees C)');
ylabel ('Per Unit of Normal Life (Hours)');
title ('Transformer Insulation Life');
set (gca, 'FontSize',20)
%%%%%%%%%%%%%%%%%%%%%%%%%%%%%%%%%%%%%%%%%%%%%%%%%%%%%%%%%%%%%%%%%%%%%%%%
figure
semilogy(CT_sort,Faa_new, 'LineWidth',4)
% legend (Aging Accelaration Factor)
grid;
xlabel ('Hot Spot Temperature (Degrees C)');
ylabel ('Aging Accelaration Factor');
title ('Aging Accelaration Factor');
set (gca, 'FontSize',20)
fname=strcat ('my', datestr(now, 'yyyymmddTHHMMSS' ));
xlswrite(fname, [{'Time (h)', 'Load (p.u.)', 'HST (Degrees C)' ,
'FAA(p.u.)', 'Cumulative age hours (h)'}]);
xlswrite (fname,[t', K_t', Cumulative_Temp', Faa', FAA_Cum'],
'A2:E25');
end

```

Harmonics Loading

```
I_factor = [100 15.42 5.58 4.56]*0.01;
H_factor = [1 3 9 15];
K_factor = (H_factor.^2).*(I_factor.^2);
K_factor = sum(K_factor);
load_increment = [0,2.025,2.475];

% B_load_gairidhara =
[1.4,1.4,1.4,1.4,1.4,1.5,1.9,1.9,2.1,2.4,2.4,2.4,2.4,2.5,2.5,2.5,2.4,
2.2,2.2,2.2,2,1.8,1.7,1.6]; % Summer

% B_load_Other_gairidhara =
[2.2,2.2,2.2,2.2,2.8,4,4.1,4.3,4.9,5.4,5.4,5.4,5.4,5.3,5.3,5.3,5.2,4.
8,4.8,4.8,4.5,4,3.8,3.4];% summer

% B_load_gairidhara =
[1.5,1.5,1.5,1.5,1.8,2.3,3.2,3.7,4.3,5.0,5.0,4.7,4.2,4.2,4,4.1,4.1,4.
5,4.4,2.8,4.1,3.5,3,2.4]; % WINTER

% B_load_Other_gairidhara =
[5,5,5,5,4.2,5.7,6.8,7.8,8.7,8.7,9.7,7.3,8.8,8.8,8.5,8.4,8.9,9,9.1,9.
2,7.9,7,7,5.4]; % WINTER

% B_load_gairidhara =
[1.5,1.5,1.5,1.5,1.8,2.3,3.2,3.7,4.3,5.0,5.0,4.7,4.2,4.2,4,4.1,4.1,4.
5,4.4,2.8,4.1,3.5,3,2.4]; % W

% B_load_Other_gairidhara =
[1,1,1,1,1,1,1,1,1,1,1,1,1,1,1,1,1,1,1,1,1]; % W

B_load_gairidhara =
[1,1,1,1,1,1,1,1,1,1,1,1,1,1,1,1,1,1,1,1,1]; % Summer

B_load_Other_gairidhara =
[3.8,3.7,3.8,3.9,4.3,5.1,6.3,7.2,7.7,8.3,8.6,8.6,8.5,8.4,8.5,8.5,8.7,
8.6,8.5,7.9,6.9,5.9,5.1,4.6];% summer

increment=1;% in MVA

% for i=1:length(B_load_gairidhara)
% B_load_gairidhara(i)=B_load_gairidhara(i)+increment;
% end

for i=1:length(load_increment)
new_load_garidhara= (1+load_increment(i))*B_load_gairidhara;
for j=1:length(new_load_garidhara)
temp=new_load_garidhara(j);
if temp>15
new_load_garidhara(j)=15.0;
end
end

Load(i).increment = load_increment(i)*100;
Load(i).Gairidhara = new_load_garidhara;
Load(i).Other_Gairidhara = B_load_Other_gairidhara;
```

```

        Load(i).system = new_load_garidhara+B_load_Other_gairidhara;
    end
    LV_winding_R = 0.0250;
    Eddy_loss = 22.7*10e3;
    Voltage = 11000;
    for i=1:length(load_increment)
        current = 1000000*(Load(i).system)/(1.7321*Voltage);
        for j=1:length(current)
            P_c(j)=
0.93*Eddy_loss/((current(j).*current(j))*LV_winding_R);
            I_max_pu(j) = sqrt((1+P_c(j))/(1+(P_c(j)*K_factor)));
            equiv_MVA(j) = I_max_pu(j)*22.5;
            equiv_HM_MVA(j)=22.5-equiv_MVA(j);
        end
        Load(i).HM = equiv_HM_MVA*load_increment(i);
        Load(i).system_HM = Load(i).system+Load(i).HM;
    end
    save loadingdata.mat Load

```

Main File Run

```

clear all;
close all;
clc;
har;
clear all;
clc;
load('loadingdata.mat');
for i=1:length(Load)
    a = HOT_calc(Load(i).system_HM);
end

```

APPENDIX D: ANNUAL LOAD DATA

FY-2078/79

Time Period (Hours)	Shrawan (MW)	Bhadau (MW)	Ashwin (MW)	Kartik (MW)	Mangsir (MW)	Poush (MW)	Magh (MW)	Falgun (MW)	Chaitra (MW)	Baishakh (MW)	Jestha (MW)	Ashadh (MW)	Annual Average Load (MW)
1	4.2	4.0	4.2	4.6	4.6	4.9	5.0	5.5	5.1	5.0	4.9	4.9	4.8
2	4.2	4.0	4.2	4.6	4.7	5.0	5.0	5.5	5.0	5.0	4.9	4.9	4.7
3	4.2	4.0	4.2	4.6	4.7	5.0	5.3	5.5	5.2	5.0	5.0	4.7	4.8
4	4.3	4.1	4.3	4.7	4.7	5.2	5.5	5.6	5.2	5.0	5.0	4.9	4.9
5	4.7	4.5	4.7	5.1	5.4	6.0	5.7	6.1	5.5	5.4	5.4	5.3	5.3
6	5.4	5.4	5.7	6.0	6.4	6.9	6.6	6.6	6.2	6.0	6.3	5.9	6.1
7	6.4	6.0	6.7	7.0	7.9	8.9	8.5	7.6	7.2	7.0	7.4	6.9	7.3
8	7.0	6.8	7.3	7.6	8.7	10.1	10.2	8.6	8.1	7.7	8.0	7.9	8.2
9	7.3	7.2	7.7	7.9	8.7	10.9	10.9	9.0	8.5	8.3	8.9	8.6	8.7
10	8.1	7.8	8.3	8.1	8.9	11.8	11.8	9.6	9.1	9.0	9.5	9.9	9.3
11	8.5	8.1	8.4	8.2	9.4	12.0	12.4	9.6	9.3	9.3	9.7	10.6	9.6
12	8.6	8.1	8.4	7.9	9.3	11.9	12.3	9.6	9.5	9.5	9.8	10.4	9.6
13	8.5	8.2	8.3	7.8	9.0	11.4	12.1	9.3	9.4	9.5	10.1	10.0	9.5
14	8.4	8.1	8.3	7.9	8.9	11.1	11.8	9.3	9.5	9.6	10.1	10.2	9.4
15	8.4	7.8	8.2	7.9	8.8	11.2	11.8	9.2	9.6	10.0	10.4	10.3	9.5
16	8.3	7.9	8.4	8.1	8.8	11.4	11.6	9.3	9.6	9.9	10.4	10.1	9.5
17	8.2	7.7	8.1	8.6	9.1	11.7	11.4	9.3	9.5	9.7	12.8	9.9	9.7
18	7.9	7.8	8.2	9.2	9.6	12.4	12.0	9.6	9.6	9.4	9.9	9.3	9.6
19	8.0	7.9	8.6	8.8	9.4	12.1	11.9	9.7	9.8	9.5	9.5	9.3	9.5
20	7.2	7.0	7.9	8.1	9.1	11.2	11.1	9.1	8.8	8.9	9.1	8.8	8.9
21	6.5	6.2	7.1	7.2	7.8	10.0	9.9	8.1	8.0	8.1	8.1	8.1	7.9
22	6.0	5.7	6.1	6.3	6.9	8.4	8.5	7.2	7.0	7.0	7.4	6.8	6.9
23	5.2	4.8	5.4	5.7	5.9	7.3	7.1	6.3	6.5	6.5	6.4	6.2	6.1
24	4.7	4.6	5.0	5.1	5.2	6.6	6.2	5.9	6.4	5.7	5.8	5.5	5.6

APPENDIX E: MONTHLY LOAD DATA

2078 Shrawan Load(MW) per day																																		
	Day	Day	Day	Day	Day	Day	Day	Day	Day	Day	Day	Day	Day	Day	Day	Day	Day	Day	Day	Day	Day	Day	Day	Day	Day	Day	Day	Day	Day	Day	Day	Day	Day	Day
Hours	1	2	3	4	5	6	7	8	9	10	11	12	13	14	15	16	17	18	19	20	21	22	23	24	25	26	27	28	29	30	31	32		
1	4.0	4.8	4.0	4.0	4.8	4.0	3.6	4.8	3.5	3.8	4.8	3.5	3.6	4.0	4.6	4.0	4.8	4.0	4.0	4.8	4.4	4.0	4.0	4.0	4.5	4.4	4.4	4.0	4.0	4.0	4.0	4.8		
2	4.0	4.8	4.0	4.0	4.8	4.0	3.6	4.8	3.5	3.8	4.8	3.5	3.6	4.0	4.6	4.0	4.8	4.0	4.0	4.8	4.4	4.0	4.0	4.0	4.5	4.8	4.4	4.0	4.0	4.0	4.0	4.8		
3	4.0	4.8	4.0	4.0	4.8	4.0	3.6	4.8	3.5	3.8	4.8	3.5	3.6	4.0	4.6	4.0	4.8	4.0	4.0	5.0	4.4	4.0	4.0	4.0	4.5	4.8	4.4	4.0	4.5	4.0	4.0	5.0		
4	4.0	4.8	4.0	4.0	4.8	4.0	3.6	5.0	3.5	3.8	5.0	3.5	3.6	5.0	4.6	4.0	5.0	4.0	4.0	5.2	4.4	4.0	4.5	4.0	4.5	5.0	4.4	4.0	4.6	4.0	4.0	5.0		
5	4.0	5.0	4.5	4.6	5.0	4.5	4.2	5.0	4.0	4.2	5.2	4.0	4.0	5.4	4.5	4.4	5.5	4.8	4.5	5.8	5.0	4.0	4.5	4.0	6.2	5.5	5.2	4.5	4.7	4.4	4.5	5.0		
6	5.0	5.5	5.0	5.2	5.0	5.5	5.2	5.8	5.0	5.2	6.0	5.0	5.0	6.0	3.0	3.0	6.0	5.2	5.5	6.2	5.4	6.8	5.0	5.2	6.5	6.5	5.6	5.5	5.2	5.4	5.5	5.8		
7	6.0	5.8	7.0	6.2	6.2	6.0	6.0	6.0	6.0	6.2	6.8	6.0	6.4	6.5	6.0	6.0	6.5	6.6	7.0	7.0	6.0	7.0	6.0	6.0	6.5	7.1	6.2	6.5	6.5	7.0	7.0	6.5		
8	7.0	6.2	7.0	6.6	7.0	6.5	7.0	7.0	5.5	7.0	6.8	7.0	7.0	7.0	7.5	6.0	7.0	7.0	8.0	7.0	7.0	7.5	6.5	7.0	7.0	7.5	7.0	7.0	7.0	7.0	7.5	7.5		
9	6.8	6.3	7.0	7.0	7.0	7.0	7.6	7.5	6.0	7.5	7.5	7.5	7.4	7.5	7.5	6.0	7.2	8.0	8.0	8.5	7.2	8.0	6.8	7.2	8.0	8.8	7.0	6.5	8.0	7.0	7.5	7.8		
10	6.8	6.5	8.0	8.0	8.5	7.0	8.0	9.0	6.0	8.4	8.2	8.0	9.0	8.8	8.0	6.0	8.0	9.0	9.0	9.0	8.1	9.0	6.8	8.2	8.0	9.8	9.4	7.0	9.0	7.0	8.5	8.5		
11	7.0	5.2	8.1	8.0	9.0	8.0	9.0	9.5	6.0	9.0	8.8	9.0	9.0	9.0	9.0	6.0	9.0	9.8	8.5	9.0	8.8	9.6	7.0	9.5	9.6	10.0	10.0	7.8	9.0	7.0	8.4	8.5		
12	7.0	6.0	8.5	8.0	8.8	8.0	9.0	9.2	6.0	9.0	8.8	9.0	9.0	9.2	9.0	7.2	9.0	9.8	9.2	9.0	8.8	9.4	7.0	9.5	9.0	10.0	10.0	8.9	9.0	7.0	8.4	9.5		
13	8.0	6.0	8.5	8.0	8.6	8.0	9.0	9.2	7.0	9.0	8.8	9.0	9.2	9.0	9.0	7.2	9.0	9.8	9.2	9.0	8.8	9.4	6.0	4.5	9.6	9.5	10.0	10.0	9.0	6.8	9.0	9.0		
14	8.0	6.0	8.5	8.0	8.2	8.0	8.8	8.8	7.0	9.0	8.5	8.5	9.0	8.8	9.0	7.0	9.0	5.3	9.2	9.0	9.0	9.4	6.0	9.0	9.6	9.5	10.0	9.0	9.0	6.8	9.0	9.0		
15	7.8	6.0	8.5	8.0	8.0	8.0	8.8	9.0	7.0	9.0	7.8	8.5	9.0	9.0	9.0	7.0	9.0	9.3	9.2	9.0	9.2	8.4	6.0	8.6	9.0	9.5	10.2	9.2	8.0	6.8	9.0	9.0		
16	7.6	6.0	8.0	8.0	8.0	8.0	8.8	8.6	0.0	9.0	8.8	8.5	9.0	8.8	8.5	7.0	9.0	9.3	9.2	9.0	9.2	8.4	7.0	8.8	9.3	9.5	10.0	9.5	9.0	6.8	9.0	8.5		
17	7.4	6.0	8.0	8.5	8.0	8.0	8.2	8.0	7.0	9.0	8.5	8.0	7.5	8.6	8.0	7.0	9.0	8.8	9.0	8.0	8.6	8.7	7.0	9.0	9.2	9.0	9.0	9.1	9.0	7.0	8.4	9.0		
18	6.0	5.5	7.0	7.8	7.5	7.6	7.8	8.0	7.0	8.2	8.5	8.0	8.8	7.0	8.0	7.0	8.5	8.0	8.0	8.0	8.3	8.7	7.8	8.8	8.6	8.5	8.4	8.0	8.0	7.0	8.0	9.0		
19	7.5	7.0	7.0	7.8	7.5	7.8	7.8	8.0	6.4	8.0	8.5	8.0	8.5	8.8	8.0	7.8	8.0	8.0	8.2	8.2	8.5	8.0	7.2	8.0	8.5	8.0	9.0	8.0	8.0	8.0	8.5	8.4		
20	7.0	7.2	7.0	7.5	7.0	7.4	7.6	7.5	7.0	6.8	7.0	6.0	7.2	4.0	7.6	7.5	7.4	8.0	7.8	6.4	7.5	7.8	6.2	8.0	7.8	7.0	7.5	7.5	7.0	7.5	7.8	7.8		
21	6.5	6.5	6.0	6.2	6.0	6.6	6.8	7.0	7.0	6.2	6.5	6.5	6.2	4.0	6.8	6.8	6.6	6.0	6.8	6.4	7.0	6.8	6.0	7.5	7.0	7.0	7.0	6.8	6.8	7.0	6.8	6.0		
22	8.5	5.5	6.0	5.8	5.0	6.0	6.0	6.0	6.0	5.8	5.5	5.4	6.0	4.0	6.0	6.0	8.4	6.0	5.8	6.0	6.0	7.8	5.0	7.0	5.8	5.8	6.0	5.8	5.4	6.0	5.8	5.4		
23	5.0	5.5	6.0	5.0	5.0	4.2	5.5	5.0	3.8	5.0	5.5	8.0	5.4	4.0	5.0	5.0	5.0	5.5	5.0	5.0	6.0	6.0	4.0	6.0	5.5	4.6	5.0	5.0	4.2	6.5	5.0	4.6		
24	4.8	5.0	6.0	4.8	5.0	4.0	5.4	5.0	3.8	4.8	5.0	3.6	5.0	4.0	5.0	4.5	4.8	4.0	4.8	4.4	5.0	4.8	4.0	5.0	5.4	4.4	4.5	4.8	4.0	6.5	5.0	4.6		

2078 Bhadra Load(MW) per day																																	
	Day	Day	Day	Day	Day	Day	Day	Day	Day	Day	Day	Day	Day	Day	Day	Day	Day	Day	Day	Day	Day	Day	Day	Day	Day	Day	Day	Day	Day	Day	Day	Day	Day
Hours	1	2	3	4	5	6	7	8	9	10	11	12	13	14	15	16	17	18	19	20	21	22	23	24	25	26	27	28	29	30	31		
1	4.0	4.0	3.0	3.8	4.5	4.8	3.8	4.0	4.8	4.0	4.0	4.0	4.0	4.0	4.0	3.8	4.0	4.5	4.2	4.0	3.8	3.8	4.0	4.6	4.0	4.0	4.0	3.8	4.0	4.0	4.2		
2	4.0	4.0	3.0	3.8	4.5	4.8	3.8	4.0	4.8	4.0	4.0	4.0	4.0	4.0	4.0	3.8	4.0	4.5	4.2	4.0	3.8	3.8	4.0	4.0	4.0	4.0	4.0	3.8	4.0	4.0	4.2		
3	4.0	4.5	3.0	3.8	4.5	4.8	3.8	4.0	4.8	4.0	4.0	4.0	4.0	4.0	4.2	3.4	4.0	4.5	4.2	4.0	3.8	3.8	4.0	4.0	4.0	4.0	4.0	3.8	4.0	4.2	4.2		
4	4.0	4.5	3.0	3.8	4.5	5.0	3.8	4.0	4.8	4.0	4.0	4.0	4.0	4.0	4.5	4.2	4.0	4.6	4.2	4.0	4.0	3.8	4.0	4.8	4.0	4.0	4.5	3.8	4.0	4.4	4.2		
5	4.4	4.5	3.8	4.6	5.0	5.2	4.2	4.8	5.0	5.0	4.0	4.5	4.6	5.0	5.0	5.0	4.0	4.8	4.6	4.5	4.0	4.4	4.0	4.5	4.4	4.5	4.8	4.0	4.5	4.6	4.6		
6	5.2	5.5	5.4	5.6	6.5	5.2	5.0	5.2	5.5	5.4	5.0	4.5	5.0	5.0	5.5	6.0	9.0	5.0	4.8	5.5	5.5	5.2	4.4	5.0	5.0	5.5	5.2	5.2	5.5	5.8	5.2		
7	6.4	6.5	6.5	7.0	7.0	6.0	5.4	5.4	6.5	6.0	5.5	5.8	5.0	6.0	5.8	6.2	4.5	6.0	5.2	7.0	5.8	6.0	6.0	6.0	5.6	5.5	6.8	6.6	6.5	6.8	5.8		
8	7.0	8.5	7.2	7.0	6.5	6.8	6.0	7.2	7.5	7.8	6.5	6.0	6.0	6.5	6.8	6.4	5.5	7.0	6.0	7.0	6.8	6.0	6.0	6.8	6.4	5.5	7.2	7.8	7.5	7.8	7.6		
9	8.0	9.0	7.5	7.8	6.5	7.0	6.0	7.4	7.8	8.0	7.0	6.0	6.0	7.5	6.8	6.8	6.5	7.0	6.5	7.5	7.8	6.1	7.5	7.0	7.0	6.0	8.0	8.0	7.5	8.0	7.8		
10	9.0	9.0	9.0	9.0	6.5	7.2	7.8	7.4	8.5	9.0	7.3	6.0	6.0	7.5	8.0	8.0	7.5	7.0	6.5	8.0	7.8	6.1	8.0	7.2	8.0	6.5	9.0	9.4	7.5	9.2	9.0		
11	9.8	8.8	8.8	9.6	7.0	7.0	8.0	9.2	9.0	9.5	7.4	6.0	7.2	7.5	8.0	8.0	8.4	7.5	6.5	8.0	7.5	8.2	8.2	7.0	8.2	7.0	9.0	10.0	7.5	9.5	9.0		
12	9.5	8.4	10.0	9.5	6.8	6.0	8.0	9.0	9.0	9.5	7.4	6.0	7.1	7.5	8.0	8.0	8.0	8.0	6.2	8.0	7.5	8.2	8.2	7.0	8.2	7.4	9.0	9.5	9.6	9.0	9.0		
13	9.5	8.4	10.8	9.2	6.8	6.0	8.0	9.0	9.0	8.8	8.0	6.0	7.1	7.0	7.8	8.0	8.4	8.0	6.5	8.0	8.0	8.2	8.2	7.0	8.0	7.2	9.5	10.1	9.6	9.0	9.0		
14	9.3	8.4	9.5	9.0	6.8	6.0	7.5	9.0	9.0	8.8	7.0	6.0	7.0	6.0	7.8	8.2	8.4	8.0	6.0	8.2	8.0	8.2	8.5	7.0	8.0	7.0	9.5	10.0	9.6	9.0	9.5		
15	4.5	8.4	9.5	7.8	6.8	6.0	6.8	9.0	9.0	9.0	7.0	6.0	7.0	6.0	7.5	8.2	8.4	8.0	6.0	8.2	8.0	8.2	8.2	7.0	7.8	7.0	9.5	9.8	9.6	9.0	9.0		
16	9.0	8.0	9.5	8.5	6.8	6.0	7.0	9.0	9.0	9.0	7.0	5.0	7.0	6.0	7.5	8.0	8.0	8.0	6.0	8.2	8.0	8.0	8.0	7.0	7.8	7.0	9.0	9.5	9.6	9.0	9.0		
17	8.8	8.0	9.5	8.1	6.8	6.0	7.8	8.7	9.0	8.6	6.0	5.0	7.0	6.5	8.0	7.5	8.0	8.0	6.0	7.8	8.0	7.8	7.6	6.5	7.5	6.8	8.0	9.0	9.0	9.0	9.0		
18	8.5	7.6	9.0	9.0	6.8	6.0	8.0	8.4	9.0	8.8	6.0	7.0	7.0	7.0	7.8	7.5	8.0	7.5	6.0	6.4	8.0	7.8	7.6	6.5	7.5	7.2	8.0	9.0	9.8	9.0	9.0		
19	8.5	6.2	8.4	8.0	8.0	6.0	8.0	8.3	8.6	9.0	7.8	7.0	7.5	7.5	7.1	7.5	8.0	8.0	7.5	7.8	7.8	7.5	8.0	7.2	7.5	8.8	9.0	9.0	9.2	9.0	8.5		
20	8.5	5.6	7.0	7.0	7.2	7.0	7.0	7.6	7.6	8.0	6.5	6.2	7.0	6.8	6.0	7.0	7.0	7.8	7.5	7.5	7.4	7.0	7.5	6.6	6.5	8.2	8.0	8.0	2.0	7.8	7.0		
21	8.5	6.2	6.6	7.0	6.0	6.4	6.0	6.0	6.2	6.0	6.0	5.0	6.0	5.8	5.0	6.0	6.0	7.0	6.0	6.2	6.5	7.0	6.5	6.0	6.0	0.0	7.4	7.0	6.0	7.4	7.0		
22	7.0	5.6	6.0	6.5	5.8	5.6	5.2	5.8	5.4	6.0	8.2	4.0	6.0	5.0	5.0	5.0	5.0	5.0	5.5	6.0	6.0	5.5	5.5	5.0	4.5	6.0	6.2	6.0	6.0	5.8	6.0		
23	4.0	4.2	4.6	6.0	5.3	3.8	4.0	5.0	4.6	6.0	4.5	4.0	6.0	4.5	4.2	5.0	5.0	4.0	5.0	5.5	5.0	5.5	4.8	4.0	4.5	5.8	7.2	5.5	5.3	5.0	5.5		
24	4.0	4.0	3.8	6.0	5.8	3.0	4.0	4.8	4.0	5.5	4.5	4.0	5.5	4.0	4.0	5.0	4.8	4.2	4.5	5.0	3.8	5.0	4.4	4.6	4.0	4.8	4.0	5.0	6.0	4.6	5.0		

		2078 Ashwin Load(MW) per day																														
	Day	Day	Day	Day	Day	Day	Day	Day	Day	Day	Day	Day	Day	Day	Day	Day	Day	Day	Day	Day	Day	Day	Day	Day	Day	Day	Day	Day	Day	Day	Day	Day
Hours	1	2	3	4	5	6	7	8	9	10	11	12	13	14	15	16	17	18	19	20	21	22	23	24	25	26	27	28	29	30	31	
1	4.0	1.0	4.8	4.5	4.8	4.4	4.0	4.0	4.0	4.0	5.0	4.0	5.0	4.0	4.4	4.5	4.5	4.4	4.0	2.8	4.4	4.5	4.8	3.6	4.5	4.8	3.8	4.5	4.8	5.0	4.0	
2	4.0	1.0	4.8	4.5	4.8	4.4	4.0	4.0	4.0	4.0	5.0	4.0	5.0	4.0	4.4	4.5	4.5	4.4	4.0	2.8	4.4	4.5	4.8	3.6	4.5	4.8	3.8	4.5	4.8	4.5	4.0	
3	4.0	1.2	4.8	4.5	4.8	4.0	4.0	4.0	4.0	4.0	5.0	4.0	5.0	4.8	4.4	4.5	4.5	4.4	4.0	2.8	4.4	4.5	4.8	3.6	4.5	4.8	3.8	4.5	4.8	4.5	4.0	
4	4.0	1.4	4.8	4.5	5.0	4.0	4.0	4.0	4.0	4.0	5.2	4.0	5.0	5.5	4.4	4.5	4.6	4.4	4.0	2.9	4.4	4.5	5.0	3.6	4.5	4.8	3.8	4.5	4.8	4.5	4.0	
5	5.0	1.5	5.0	5.0	5.3	4.8	4.0	4.2	5.0	5.0	5.4	5.4	5.5	5.0	5.2	4.5	4.8	5.0	6.0	3.0	4.8	5.0	5.5	3.6	5.0	5.0	4.4	4.5	4.9	4.5	5.0	
6	6.0	1.8	5.4	6.0	6.0	5.4	7.0	5.0	6.0	5.5	6.0	6.4	6.5	6.0	6.6	5.0	5.5	6.0	6.0	6.1	5.0	6.5	5.8	6.0	6.5	5.8	5.8	5.0	5.2	4.8	5.0	
7	7.1	6.5	6.0	7.0	7.0	6.4	7.0	7.0	7.0	7.0	7.4	7.0	7.0	7.0	7.0	7.0	7.5	8.0	7.5	7.8	7.4	8.0	6.8	7.2	7.0	6.2	6.0	6.0	6.0	5.0	6.0	
8	7.1	7.0	7.0	8.0	8.0	8.0	8.0	7.5	7.0	8.0	8.0	8.0	7.0	8.0	8.0	7.0	7.5	8.0	8.0	7.5	7.8	7.4	8.0	6.8	7.4	7.2	6.8	6.2	6.0	6.0	5.8	6.0
9	8.0	7.0	7.2	8.5	8.1	8.2	8.0	8.1	8.0	9.0	8.1	8.2	9.0	8.1	8.5	7.5	8.0	8.0	8.0	8.0	8.0	9.0	6.5	8.0	8.0	7.0	6.0	6.0	6.0	6.0	6.5	
10	9.0	7.5	8.0	9.0	9.0	8.0	9.0	9.0	8.0	9.0	9.5	9.4	9.0	9.0	9.2	7.5	8.5	9.0	9.5	9.0	8.0	9.0	7.8	8.8	9.0	7.0	6.2	6.5	6.0	6.2	7.5	
11	9.0	7.5	8.5	9.8	9.8	8.1	9.0	9.5	8.0	9.2	9.5	9.8	9.0	9.0	9.0	7.4	9.0	9.8	9.5	9.5	8.8	9.5	7.8	9.2	8.0	7.0	6.8	5.4	5.0	6.0	7.0	
12	9.0	7.5	8.2	9.8	9.6	8.1	9.0	9.5	8.0	9.2	9.5	8.5	9.2	9.8	9.4	7.0	9.0	8.0	9.5	9.5	8.5	9.5	8.0	9.2	9.0	7.0	6.8	6.4	5.0	6.0	7.0	
13	8.6	6.0	7.8	10.0	9.8	9.0	9.0	9.5	7.2	9.2	9.5	9.1	9.2	9.8	9.4	7.0	9.0	9.4	9.2	9.5	8.4	9.5	8.0	9.2	8.8	6.0	6.5	6.4	5.0	5.8	7.2	
14	8.6	6.0	7.8	10.0	9.8	9.0	9.0	9.8	7.5	9.0	9.0	9.2	9.2	9.8	9.2	7.0	9.0	9.0	9.2	9.5	8.4	9.5	8.0	9.5	8.0	6.0	6.5	6.4	5.0	5.8	7.2	
15	8.6	6.0	7.8	10.0	9.8	9.0	9.0	9.5	7.5	9.0	9.0	9.0	9.2	9.0	4.1	7.8	9.0	9.8	9.2	9.5	8.6	9.7	8.0	9.2	8.0	7.0	6.5	6.4	5.3	6.0	7.2	
16	8.0	6.5	9.0	9.6	9.8	9.0	9.0	9.5	7.2	8.8	9.0	9.0	9.0	9.0	9.0	7.6	9.0	9.6	9.2	9.5	8.6	9.5	8.0	9.2	9.0	7.0	6.5	6.4	5.3	6.2	7.0	
17	8.0	6.0	8.0	9.6	9.3	9.0	9.0	9.5	7.8	8.8	2.0	9.0	9.0	9.0	8.2	7.4	9.0	8.0	9.2	9.5	9.0	9.2	8.5	9.1	9.0	7.0	6.8	6.0	6.4	6.2	7.2	
18	8.8	7.0	8.8	9.6	9.0	9.0	9.8	9.5	8.0	9.0	2.0	8.8	9.2	9.5	9.5	8.0	10.0	8.9	9.4	10.0	9.5	9.4	9.0	9.0	9.0	8.0	7.0	6.4	6.6	0.0	7.8	
19	8.0	8.6	9.0	9.0	9.0	9.0	9.0	9.0	9.0	9.5	9.0	9.0	9.3	9.0	9.5	9.0	8.2	9.0	9.6	9.6	8.0	9.8	9.0	9.0	9.0	8.0	7.0	7.0	6.0	6.8	7.8	
20	7.8	7.8	8.5	8.0	8.0	8.0	7.3	8.4	8.0	8.1	8.0	9.0	8.0	8.4	9.0	8.0	8.0	8.0	8.0	8.4	6.5	9.0	8.4	9.0	8.5	7.6	7.0	6.8	6.0	6.8	6.8	
21	7.0	7.0	7.5	7.0	7.0	6.5	7.3	7.4	8.0	7.2	7.4	8.0	7.3	7.8	7.5	7.0	7.0	7.0	7.6	7.0	5.5	8.0	7.4	8.0	7.5	6.0	6.5	6.2	6.0	6.5	6.6	
22	6.0	6.4	6.5	6.3	7.0	5.0	6.5	6.0	6.0	6.0	6.2	7.0	6.0	7.4	6.5	6.0	5.8	6.0	6.2	6.0	5.4	6.0	6.0	6.6	6.0	5.0	6.5	6.0	5.4	6.0	5.8	
23	5.8	5.8	6.0	5.8	4.8	5.0	6.0	5.0	5.5	5.1	4.4	5.0	5.8	5.4	6.0	5.8	4.8	5.3	5.8	5.0	5.0	5.8	4.8	6.5	6.0	4.4	5.0	5.4	5.0	5.5	5.0	
24	5.5	4.8	6.0	5.5	4.8	4.5	5.8	4.0	5.0	5.0	4.0	5.0	5.5	4.4	5.5	9.5	4.4	5.0	4.0	4.4	4.0	5.5	4.0	5.0	5.8	3.8	4.0	4.5	5.0	5.0	4.8	

2078 Kartik Load(MW) per day																														
	Day	Day	Day	Day	Day	Day	Day	Day	Day	Day	Day	Day	Day	Day	Day	Day	Day	Day	Day	Day	Day	Day	Day	Day	Day	Day	Day	Day	Day	Day
Hours	1	2	3	4	5	6	7	8	9	10	11	12	13	14	15	16	17	18	19	20	21	22	23	24	25	26	27	28	29	30
1	4.8	4.4	4.0	4.8	4.6	4.5	4.8	4.4	4.0	4.8	4.4	4.5	4.0	4.0	4.0	4.8	4.8	4.5	4.8	4.8	5.0	4.8	4.8	4.5	4.8	4.8	5.0	5.0	5.0	4.5
2	4.8	4.4	4.0	4.8	4.6	4.5	4.8	4.4	4.0	4.8	4.4	4.5	4.0	4.0	4.0	4.8	4.8	4.5	4.8	4.8	5.0	4.5	4.8	4.5	4.8	4.8	5.0	5.0	5.0	4.5
3	4.8	4.4	4.0	4.8	4.6	4.5	4.5	4.4	4.0	4.0	4.0	4.5	4.0	4.0	4.0	4.8	4.8	4.5	5.0	4.8	5.0	4.8	4.8	4.5	4.8	4.8	5.0	5.0	5.0	4.5
4	4.8	4.4	4.0	5.0	4.6	4.5	5.0	4.4	4.0	5.8	4.4	4.5	4.0	4.0	4.0	5.0	4.8	4.5	5.2	4.8	5.0	4.8	4.8	4.5	5.0	4.8	5.0	5.2	5.0	4.5
5	5.0	5.0	4.5	5.0	5.0	5.0	5.0	5.0	4.5	6.0	5.4	5.0	4.6	4.8	5.8	5.0	5.4	5.0	5.2	5.4	5.2	5.0	5.4	5.0	5.5	5.4	5.0	5.5	5.4	5.0
6	5.5	6.0	6.0	5.8	5.6	5.5	5.5	6.2	5.5	7.1	6.0	6.0	5.6	6.0	6.0	5.8	6.4	6.5	6.0	6.0	5.0	6.0	6.4	6.5	6.0	6.2	6.0	6.0	6.0	6.5
7	6.1	6.8	6.5	6.8	6.4	6.0	5.5	7.0	8.0	8.0	7.2	8.0	6.4	7.2	7.0	7.5	7.8	7.0	6.8	7.0	6.0	6.8	6.8	7.0	7.3	7.0	6.5	7.8	7.2	8.0
8	6.8	7.0	7.0	7.5	7.6	7.0	7.5	7.6	8.0	8.0	8.0	8.0	7.2	7.6	8.0	8.0	7.8	7.5	7.0	7.0	6.2	7.8	7.2	7.8	8.0	8.0	8.0	8.5	8.1	8.5
9	7.2	7.0	8.0	7.8	8.0	7.5	7.8	8.0	8.0	8.2	8.0	9.0	7.6	8.0	8.0	8.0	8.0	7.5	7.0	7.0	7.0	7.8	7.8	8.0	8.0	8.2	8.0	7.8	8.8	9.0
10	7.5	7.2	8.0	8.5	8.2	7.0	8.0	8.0	8.5	8.2	8.5	9.0	7.8	8.0	8.5	8.2	8.4	7.5	7.0	7.0	7.0	8.1	8.2	8.0	8.5	8.6	8.0	8.8	9.0	9.0
11	7.8	8.0	8.0	8.5	8.5	7.0	8.5	8.8	8.5	8.2	9.0	8.5	7.8	8.5	9.0	8.0	9.0	7.5	6.5	6.0	7.0	9.0	8.8	8.0	8.5	9.0	7.8	9.0	9.2	9.2
12	7.6	7.8	8.2	8.5	8.1	7.0	8.5	8.8	8.2	8.0	8.5	8.5	7.5	8.2	9.0	8.5	8.8	7.0	6.5	5.2	7.5	9.0	8.1	8.0	9.0	9.0	7.2	9.0	4.0	9.2
13	7.6	7.8	8.2	8.5	8.2	7.0	8.5	8.8	8.2	8.0	8.6	8.5	6.0	8.2	9.0	8.5	8.8	7.0	6.5	5.0	6.2	8.5	8.0	7.4	9.0	8.6	7.2	9.0	4.0	9.2
14	7.3	7.8	8.2	9.0	8.3	7.0	8.3	8.8	8.5	8.0	8.6	8.0	6.0	8.0	9.0	8.5	8.6	7.0	6.5	5.0	6.4	8.0	8.0	7.4	9.0	8.6	7.2	9.0	9.0	9.2
15	7.3	7.8	8.2	7.5	8.1	7.0	9.0	8.8	8.4	8.0	8.8	8.5	6.5	8.2	8.0	8.5	8.4	7.0	6.5	5.0	6.8	8.0	8.1	7.4	9.0	8.5	7.2	9.0	9.0	9.2
16	7.0	7.0	8.2	7.5	8.1	7.2	9.0	9.8	8.4	8.3	8.8	8.5	7.0	8.5	9.0	8.5	8.8	7.0	6.5	5.5	7.0	8.0	8.5	8.0	9.0	8.5	7.2	9.0	9.0	9.2
17	7.5	8.4	8.2	9.0	8.5	8.0	9.0	8.5	8.8	8.3	9.1	9.0	8.0	8.5	9.2	9.5	8.5	8.0	8.0	6.0	8.0	9.0	8.6	8.4	9.0	9.8	8.0	9.0	9.5	10.0
18	8.5	8.5	9.0	9.0	9.0	8.8	9.0	9.0	8.8	9.6	9.0	9.8	8.5	9.8	9.4	9.5	9.8	9.6	9.0	7.2	8.6	9.0	9.8	9.2	10.0	10.0	9.2	9.5	10.3	9.8
19	7.8	8.0	8.6	8.4	8.5	8.0	8.8	9.0	7.8	8.8	8.4	9.0	8.4	9.0	9.0	9.0	9.5	9.8	9.0	8.0	8.0	9.0	9.5	9.1	9.2	9.0	9.0	9.8	9.5	8.8
20	7.2	8.8	7.5	8.0	8.0	7.0	7.8	8.0	8.2	7.0	8.0	7.8	7.8	9.0	8.5	8.5	9.0	9.0	8.0	7.5	7.5	7.8	8.5	8.2	8.0	8.5	8.0	9.0	9.0	7.8
21	6.0	5.8	7.0	7.0	7.5	6.8	7.0	8.0	9.0	7.0	8.5	7.4	6.4	7.0	7.0	7.2	6.0	8.5	7.5	7.5	7.0	7.0	8.0	7.0	7.0	8.0	7.2	7.8	8.0	6.0
22	5.4	5.8	6.0	6.0	6.0	5.8	6.0	5.8	6.8	6.0	8.5	6.0	6.0	6.0	5.8	6.0	6.0	8.0	7.0	6.0	6.0	6.2	8.0	6.0	6.4	7.0	6.0	6.6	7.0	6.0
23	4.8	5.5	5.0	5.4	6.0	5.8	5.0	5.3	6.0	5.0	6.0	5.0	5.0	6.5	5.0	5.2	6.0	7.5	5.4	5.5	5.5	5.4	7.5	6.0	5.0	6.5	5.5	5.8	6.5	5.8
24	4.4	5.5	4.8	4.6	5.3	5.5	4.4	4.5	4.8	4.4	6.0	4.0	4.0	5.5	4.5	4.8	6.0	7.0	4.8	5.5	5.0	4.8	6.0	5.8	4.8	6.0	5.0	5.0	6.0	5.5

2078 Mangsir Load(MW) per day																														
	Day	Day	Day	Day	Day	Day	Day	Day	Day	Day	Day	Day	Day	Day	Day	Day	Day	Day	Day	Day	Day	Day	Day	Day	Day	Day	Day	Day		
Hour	1	2	3	4	5	6	7	8	9	10	11	12	13	14	15	16	17	18	19	20	21	22	23	24	25	26	27	28	29	
1	5.8	5.8	5.5	4.8	4.8	4.5	4.8	4.8	4.0	4.0	4.0	4.0	4.0	5.1	5.0	4.8	4.5	4.5	4.8	4.8	4.5	4.8	4.8	4.5	4.5	4.4	4.5	4.5	4.0	
2	5.8	5.8	5.5	4.8	4.8	4.5	4.8	4.8	4.0	4.0	4.0	4.0	4.5	5.1	5.0	4.8	4.5	4.5	4.8	4.8	4.5	4.8	4.8	4.5	4.6	4.4	4.5	4.5	4.0	
3	5.8	5.8	5.5	4.8	4.8	4.5	4.8	4.8	4.0	4.2	4.0	4.0	4.5	5.1	5.0	4.8	4.5	4.5	5.0	4.8	4.5	4.8	4.8	4.5	4.8	4.4	4.5	4.5	4.0	
4	6.0	5.8	5.5	5.8	4.8	4.5	4.0	4.8	4.5	4.4	4.0	4.0	5.0	5.1	5.0	5.0	4.5	4.5	5.0	4.8	4.5	3.0	5.0	4.5	5.0	4.4	4.5	4.8	4.0	
5	6.0	5.8	6.0	5.0	5.8	6.5	5.0	6.0	6.5	5.0	5.0	5.0	5.5	5.1	5.0	5.5	5.5	5.0	5.8	5.4	5.0	3.5	5.5	5.0	5.5	4.8	5.5	4.8	5.2	
6	6.0	6.0	6.5	5.4	7.0	7.5	5.8	7.0	8.0	6.8	6.0	6.5	6.5	5.1	6.5	6.5	6.0	6.0	6.0	6.2	6.0	6.0	6.0	8.0	6.8	5.5	7.0	5.0	7.0	
7	8.0	7.8	8.0	7.0	7.4	7.0	8.0	7.8	8.0	8.0	7.0	8.0	8.0	6.2	9.0	8.0	8.0	7.5	7.5	8.4	7.5	7.8	7.5	9.0	7.8	7.5	9.0	8.5	9.6	
8	8.8	9.0	9.0	8.0	7.4	8.5	8.4	8.2	8.0	8.5	8.0	8.0	9.0	8.0	9.0	9.0	9.0	8.0	8.8	9.0	9.0	8.3	9.0	9.5	8.8	8.4	9.5	10.0	10.0	
9	8.8	9.2	8.0	8.2	8.0	8.5	8.2	8.2	9.0	9.8	8.5	9.0	9.0	9.0	9.0	9.0	9.5	9.0	8.1	8.0	9.0	4.5	8.5	9.5	9.0	9.2	10.0	9.8	10.2	
10	9.0	9.5	9.0	8.1	8.1	8.5	8.3	9.0	9.2	9.0	8.5	9.0	4.5	9.0	9.0	9.5	10.0	9.0	9.0	9.5	9.5	4.0	10.0	9.5	9.0	9.6	11.0	9.8	10.2	
11	9.5	10.0	9.2	8.0	8.8	8.4	9.0	9.0	9.0	9.5	8.0	9.2	10.0	9.3	9.5	9.5	10.0	8.5	9.5	9.2	9.5	9.5	10.0	10.0	9.2	10.0	10.2	10.8	11.5	
12	9.5	9.8	9.2	7.5	8.2	8.4	8.3	8.8	9.0	10.0	8.0	9.0	10.0	10.0	9.2	9.5	9.8	8.0	9.0	9.2	9.0	9.5	9.8	10.0	8.0	9.8	10.2	11.0	11.0	
13	9.0	10.0	9.2	6.0	8.0	8.4	8.5	8.5	9.0	9.5	8.6	9.0	9.5	9.5	9.0	9.0	9.8	7.5	9.0	8.5	9.0	9.0	9.0	10.0	7.5	9.6	9.8	11.0	10.5	
14	9.0	9.8	9.0	7.0	8.0	8.4	8.5	8.5	9.0	9.5	7.2	8.8	9.5	9.5	9.0	9.0	9.1	7.0	9.0	9.0	9.0	9.0	9.0	9.0	9.0	7.5	9.6	9.8	10.0	10.0
15	9.0	9.8	9.0	7.0	8.0	8.0	8.5	8.2	9.0	9.5	7.2	9.0	9.0	9.0	9.0	9.0	9.0	7.0	9.0	9.5	9.0	9.0	9.0	9.0	9.0	7.1	9.6	9.8	10.0	10.0
16	9.0	9.8	9.2	7.0	8.0	7.0	8.5	8.5	9.2	9.5	6.0	9.0	9.0	9.0	9.0	9.0	9.8	7.0	9.0	9.0	9.0	9.0	9.0	9.0	7.5	9.0	9.8	10.0	10.2	
17	10.0	8.6	9.8	8.0	8.0	8.0	9.5	9.0	9.2	9.0	8.0	9.0	9.5	9.0	9.5	9.0	10.1	7.8	9.5	9.5	9.5	9.0	4.8	10.0	9.0	10.0	10.4	10.0	10.8	
18	10.0	9.1	9.5	8.0	4.5	7.8	9.2	9.8	9.8	10.0	4.1	10.0	10.0	10.2	10.5	10.0	10.5	8.4	10.0	10.0	10.2	10.5	10.5	10.6	10.0	11.0	11.5	10.5	11.5	
19	9.6	10.0	4.1	10.0	0.0	9.8	9.0	9.0	9.0	10.0	9.2	9.8	10.0	10.5	10.0	9.5	10.0	9.1	9.6	9.5	9.8	10.4	10.0	10.6	9.8	11.0	11.0	11.5	11.0	
20	8.4	9.0	8.8	8.2	9.0	8.8	8.0	8.5	8.0	9.2	8.5	9.5	9.6	9.5	9.5	9.5	9.0	8.8	8.4	9.0	9.0	9.5	9.0	9.2	9.8	10.0	10.0	10.6	11.0	
21	8.0	8.0	7.2	8.0	7.5	8.0	7.0	7.0	7.8	8.4	8.0	8.5	8.0	8.0	8.0	8.0	8.0	7.2	7.4	7.5	7.8	8.0	9.0	8.6	8.4	8.3	8.2	10.0	9.5	
22	7.0	7.0	6.5	6.0	6.5	7.3	5.4	6.5	7.0	8.0	6.5	8.0	6.5	7.0	6.8	6.0	7.0	7.0	6.2	7.0	5.2	6.5	7.5	7.0	7.8	8.0	7.0	8.0	7.5	
23	6.1	6.0	6.0	5.2	6.5	6.0	5.2	5.5	6.8	6.0	5.0	6.8	5.5	6.0	6.0	6.0	6.5	6.5	5.4	6.5	5.0	5.5	5.0	5.8	4.8	6.0	6.8	6.0	6.5	
24	5.8	6.0	5.0	4.8	6.0	4.8	4.8	4.0	6.0	4.0	5.0	5.8	5.5	5.5	5.0	5.0	6.0	6.0	4.8	6.0	4.2	4.8	4.8	5.0	4.5	5.0	6.0	4.8	6.0	

2078 Poush Load(MW) per day																																
	Day	Day	Day	Day	Day	Day	Day	Day	Day	Day	Day	Day	Day	Day	Day	Day	Day	Day	Day	Day	Day	Day	Day	Day	Day	Day	Day	Day	Day	Day	Day	Day
Hour	1	2	3	4	5	6	7	8	9	10	11	12	13	14	15	16	17	18	19	20	21	22	23	24	25	26	27	28	29	30		
1	4.5	4.8	4.8	5.0	4.8	4.8	5.0	4.8	4.8	4.8	4.8	4.8	5.0	4.8	4.8	6.5	4.8	4.8	5.5	4.0	4.8	5.5	5.1	5.4	5.2	4.8	4.8	5.5	4.5	4.6		
2	4.5	4.8	4.8	5.0	4.8	4.8	5.0	4.8	4.8	4.8	4.8	4.8	5.0	4.8	4.8	6.5	4.8	4.8	5.5	4.0	4.8	5.5	5.5	5.4	5.2	4.8	4.8	5.5	4.5	4.6		
3	4.5	4.9	4.8	5.0	4.8	4.8	5.0	4.8	4.8	5.0	5.0	4.8	5.0	5.0	4.8	6.5	4.8	4.8	5.5	5.0	4.8	5.5	6.0	5.4	5.2	4.8	4.8	5.5	4.6	4.6		
4	5.5	5.0	4.8	5.0	5.0	4.8	5.1	4.9	4.8	5.2	5.8	4.8	5.0	5.0	4.8	6.5	5.0	4.8	5.5	5.5	5.4	5.5	6.2	5.4	5.0	5.2	4.8	5.5	5.0	4.6		
5	6.0	5.2	5.6	5.5	6.0	6.0	6.5	6.2	5.2	5.5	6.0	5.6	6.0	5.8	5.4	6.0	5.0	8.8	6.0	6.0	7.6	6.5	6.5	6.2	6.5	5.8	5.2	6.0	5.5	5.2		
6	7.0	5.8	6.8	7.0	7.5	7.2	7.1	6.5	6.0	6.0	6.5	6.8	7.5	5.8	7.6	8.0	6.0	8.0	7.5	6.0	9.0	8.0	7.0	7.0	7.0	7.8	6.4	7.0	6.0	6.2		
7	9.0	9.0	8.4	9.0	9.0	8.0	9.5	8.5	9.0	7.5	9.0	9.0	9.5	7.0	9.0	10.0	10.0	8.6	10.0	9.5	11.0	9.0	9.8	8.0	7.0	9.0	8.0	9.0	8.5	8.0		
8	9.5	10.5	9.0	9.5	11.0	10.8	11.0	10.0	9.0	9.0	10.5	10.2	11.0	10.5	11.0	11.1	10.5	10.8	10.5	9.1	11.5	10.0	11.0	9.6	9.5	10.1	10.4	10.5	10.1	7.0		
9	10.5	10.5	9.8	9.5	11.1	11.0	11.0	10.1	10.2	9.0	10.8	11.0	12.0	12.0	11.6	13.0	11.0	11.0	11.0	11.0	13.0	11.0	11.0	10.0	10.0	11.0	11.0	11.0	10.8	12.0		
10	11.0	11.5	9.6	10.0	12.0	11.6	11.5	11.5	11.2	9.0	12.0	13.0	12.0	13.4	13.0	14.0	11.1	13.0	12.0	11.8	13.8	12.0	12.2	10.2	10.5	12.0	11.0	12.0	12.5	13.0		
11	11.0	10.0	9.5	9.0	12.0	12.1	12.0	12.0	11.8	8.4	13.0	13.2	12.0	13.0	14.0	15.0	11.0	13.0	14.0	11.1	13.5	12.0	13.0	10.0	11.5	13.0	11.1	12.4	13.0	14.0		
12	11.0	11.0	9.0	9.0	11.5	11.8	12.0	11.5	11.5	7.0	13.0	12.2	14.8	13.0	14.0	12.0	10.0	12.5	13.0	12.0	12.5	13.8	14.0	10.0	12.0	12.5	11.1	12.4	12.0	13.5		
13	11.0	10.0	8.3	9.0	11.0	11.5	9.4	11.0	10.8	8.0	12.0	9.0	14.8	13.0	11.0	13.0	9.0	12.7	12.5	12.0	13.1	12.0	13.0	10.0	12.0	12.5	12.0	13.0	11.5	12.8		
14	7.3	10.0	8.0	9.0	11.0	11.0	9.8	11.0	10.5	8.4	12.0	11.9	14.4	12.5	13.0	13.0	9.0	12.0	12.2	12.1	13.8	12.0	13.0	4.0	12.0	12.0	11.8	13.4	9.3	12.2		
15	10.0	10.5	8.0	8.0	11.0	11.0	10.0	11.0	10.2	8.4	12.0	13.0	14.0	13.0	13.0	12.5	9.0	12.1	12.6	12.5	13.2	12.0	12.3	4.1	12.0	12.0	11.5	13.4	10.5	11.8		
16	10.0	10.0	7.0	9.4	11.5	11.0	9.6	11.0	9.0	9.0	12.5	12.6	14.0	13.0	13.0	12.5	9.5	12.5	12.6	12.5	13.2	12.0	13.0	9.8	12.0	12.0	11.5	13.0	11.5	11.8		
17	10.4	11.0	7.5	10.4	12.0	11.5	11.0	11.0	9.8	10.0	13.0	13.0	14.0	12.0	13.1	13.0	10.0	12.3	12.8	13.0	13.1	12.6	13.0	10.2	12.0	12.0	11.5	12.4	11.5	11.8		
18	12.0	12.0	10.5	11.5	13.0	12.0	11.0	11.0	11.5	10.8	13.0	13.0	14.0	12.5	14.0	13.5	12.0	13.0	13.5	13.5	13.8	12.8	13.0	11.5	12.0	13.0	12.0	12.6	12.3	12.5		
19	10.0	11.0	11.0	11.8	11.6	12.0	11.1	11.0	11.0	11.0	12.5	13.0	13.0	13.2	13.5	13.5	12.5	13.0	13.0	12.1	13.0	12.5	12.0	11.5	12.8	12.0	12.0	12.5	13.0	12.0		
20	9.2	10.2	11.0	10.0	10.4	11.5	10.1	10.6	10.5	11.0	11.4	11.0	12.0	12.5	13.0	12.0	12.2	12.0	12.3	11.0	12.0	11.8	12.0	11.0	12.0	10.0	11.0	11.5	12.0	10.0		
21	9.8	9.0	9.5	9.2	9.8	10.5	9.5	9.9	4.5	10.0	10.0	10.5	11.0	11.4	9.0	12.0	10.4	11.0	11.0	9.4	11.0	10.0	10.4	10.0	11.0	10.0	10.0	9.0	11.0	11.0		
22	8.0	7.6	8.0	7.0	7.2	8.5	8.1	4.4	8.0	9.8	8.0	9.0	8.8	9.8	8.0	10.5	8.4	9.0	10.5	6.4	10.0	8.0	8.0	8.0	10.1	8.4	8.5	8.0	10.0	9.0		
23	7.5	5.2	7.3	6.0	5.1	6.5	7.8	6.6	8.0	4.0	6.0	8.5	8.0	8.0	8.0	10.0	6.0	8.0	10.0	4.8	10.0	7.8	6.4	7.5	8.5	6.6	9.0	7.0	8.2	7.5		
24	7.5	4.8	7.5	6.0	4.8	6.0	7.5	5.4	7.8	5.0	4.2	8.0	7.8	4.8	6.5	7.8	5.0	7.0	9.5	4.8	9.5	7.8	5.4	6.5	6.5	7.8	8.0	5.0	7.0	6.0		

2078 Magh Load(MW) per day																													
	Day	Day	Day	Day	Day	Day	Day	Day	Day	Day	Day	Day	Day	Day	Day	Day	Day	Day	Day	Day	Day	Day	Day	Day	Day	Day	Day	Day	Day
Hours	1	2	3	4	5	6	7	8	9	10	11	12	13	14	15	16	17	18	19	20	21	22	23	24	25	26	27	28	29
1	5.2	4.8	4.8	5.5	4.8	4.8	5.5	4.5	4.5	5.0	4.8	4.8	5.5	1.0	5.4	5.5	4.8	6.0	5.5	5.0	5.0	5.5	5.0	5.5	5.0	5.0	5.0	6.0	
2	5.5	4.8	4.8	5.5	4.8	4.8	5.5	5.0	4.8	5.0	4.8	4.8	5.5	1.0	5.4	5.5	4.0	6.0	5.5	5.0	5.0	5.5	5.0	5.5	5.0	5.0	5.0	6.0	
3	5.5	5.0	4.8	5.5	5.0	4.8	5.5	5.6	4.8	5.0	9.0	4.8	5.5	1.5	5.4	5.5	5.0	6.0	5.5	5.5	5.0	5.5	5.5	5.0	5.5	5.0	5.0	6.0	
4	5.5	5.5	4.8	5.5	5.5	4.8	5.5	6.0	4.8	5.0	9.5	4.8	5.5	2.0	5.4	5.5	5.5	6.0	5.5	5.7	5.0	5.5	5.8	5.0	6.0	5.2	5.0	5.0	8.0
5	5.5	6.0	5.6	6.5	6.0	5.4	6.5	6.0	5.6	6.5	5.0	5.4	6.0	2.5	6.2	6.0	5.8	6.4	6.0	6.0	6.2	6.5	6.0	6.0	6.5	5.3	2.0	6.5	6.2
6	6.0	6.5	7.2	8.0	6.8	5.4	6.0	7.0	6.6	6.5	5.5	7.4	7.5	3.5	7.0	8.0	6.0	7.0	6.5	6.5	7.8	7.0	7.8	7.6	8.0	6.0	2.4	8.0	6.5
7	7.0	8.0	9.0	9.0	8.0	7.4	9.0	8.0	9.0	8.0	8.0	8.0	8.0	8.5	8.0	9.5	8.5	8.2	11.0	8.0	9.0	8.0	8.5	8.8	11.0	8.2	8.6	9.0	7.5
8	8.5	10.0	11.0	10.0	10.0	8.6	10.0	9.8	10.0	10.0	10.5	11.0	10.5	10.0	9.0	10.0	10.2	10.4	11.0	10.8	11.0	10.0	11.5	10.8	11.5	10.0	10.0	9.8	8.8
9	9.5	10.8	11.0	10.5	10.8	11.0	11.0	10.0	10.4	11.0	11.5	11.0	13.0	11.0	10.0	11.0	11.5	11.0	11.0	11.4	12.0	11.0	11.2	11.4	12.0	11.2	10.8	9.8	9.0
10	10.0	11.8	11.0	12.0	11.8	12.0	11.5	10.5	11.0	13.0	12.5	13.0	13.0	12.8	10.0	12.8	12.5	12.0	11.0	13.0	13.0	11.0	12.1	12.4	13.0	12.2	11.8	10.0	9.0
11	10.0	13.0	11.5	12.0	12.0	14.5	12.0	10.0	14.0	13.4	13.0	11.0	13.6	14.0	10.0	12.8	13.3	12.8	11.0	14.0	17.0	10.6	13.0	13.2	13.0	13.0	12.1	11.5	9.0
12	9.0	12.0	12.2	12.0	12.0	14.0	12.0	9.8	14.0	14.0	13.0	15.0	13.6	13.0	9.0	12.4	13.2	13.0	11.0	13.3	17.0	10.0	13.0	13.0	12.0	13.0	11.8	12.0	8.5
13	8.5	12.0	12.0	11.0	12.0	14.4	12.0	9.8	14.0	14.0	13.0	14.8	12.0	12.5	9.0	12.4	12.2	12.6	11.4	12.5	16.5	10.6	12.0	12.5	12.0	13.0	11.5	12.0	8.0
14	8.0	11.5	12.0	11.0	12.0	14.1	13.0	9.8	13.5	14.0	12.5	13.5	11.0	12.5	8.8	12.5	12.2	13.4	11.4	12.5	15.8	10.6	12.0	11.0	12.0	12.0	11.0	11.4	8.1
15	8.0	11.5	12.0	11.0	12.0	14.0	13.0	9.6	12.8	14.0	12.0	13.0	11.0	12.0	8.8	12.5	12.2	14.0	12.6	12.5	14.8	10.6	12.0	12.0	11.6	12.0	11.0	11.0	8.1
16	8.0	11.5	11.8	11.0	11.5	12.0	12.0	11.0	12.5	13.6	12.0	12.5	11.0	12.0	9.5	12.6	12.2	14.0	12.8	13.0	12.8	9.8	12.0	12.0	11.6	10.5	11.0	11.0	8.0
17	8.2	11.0	12.0	11.0	12.0	12.0	12.0	11.0	12.0	12.8	12.0	12.5	12.0	11.5	9.8	12.6	11.8	13.0	12.5	12.5	13.0	9.8	12.0	9.5	11.4	11.0	11.0	10.0	8.5
18	9.8	12.0	12.1	12.0	12.0	13.5	12.5	11.5	12.5	13.0	12.5	12.8	12.2	13.0	10.8	12.8	12.3	13.0	12.5	13.0	13.8	11.5	11.5	12.0	12.0	11.0	11.0	10.4	10.0
19	10.4	12.0	12.3	11.8	11.4	12.0	12.5	11.4	12.5	12.5	11.4	12.8	12.0	12.0	11.5	12.5	12.0	12.0	12.0	12.0	13.0	12.0	11.4	12.0	11.8	11.8	11.5	11.1	10.2
20	11.0	11.0	12.0	10.8	10.0	11.3	11.8	10.6	12.0	11.6	11.0	12.0	11.8	11.6	11.0	11.5	11.0	10.5	11.0	11.0	12.0	11.5	10.4	11.8	11.1	11.0	11.0	10.8	9.0
21	10.8	9.0	11.0	9.5	9.6	9.5	10.2	9.4	10.0	10.5	9.8	11.0	10.0	10.6	11.0	11.8	10.2	10.0	9.8	5.0	11.0	10.0	8.8	10.0	10.0	9.8	10.0	10.0	9.0
22	9.8	8.4	9.5	7.8	7.4	8.0	8.5	7.4	8.5	8.0	8.0	10.0	9.6	8.4	10.0	8.8	9.0	8.0	8.8	7.0	9.0	8.6	7.0	9.0	8.2	7.8	8.0	9.8	7.5
23	8.0	5.4	8.0	6.8	6.4	6.0	7.8	5.2	8.0	7.5	6.0	8.5	8.8	6.6	8.0	5.0	7.5	6.5	8.0	6.6	7.0	8.5	5.0	8.5	9.0	6.0	7.5	7.2	6.0
24	6.5	4.8	6.5	6.5	4.8	5.5	2.0	4.8	7.5	7.5	4.8	8.0	8.2	5.0	8.0	7.5	6.0	6.0	7.5	6.0	6.0	5.0	5.0	8.0	8.5	5.0	6.5	7.0	5.4

2078 Falgun Load(MW) per day																														
	Day	Day	Day	Day	Day	Day	Day	Day	Day	Day	Day	Day	Day	Day	Day	Day	Day	Day	Day	Day	Day	Day	Day	Day	Day	Day	Day	Day	Day	Day
Hours	1	2	3	4	5	6	7	8	9	10	11	12	13	14	15	16	17	18	19	20	21	22	23	24	25	26	27	28	29	30
1	6.0	6.0	5.8	5.8	5.8	5.8	5.8	5.5	5.5	5.8	5.5	4.8	5.0	5.0	5.8	5.8	5.8	6.0	5.0	5.0	5.8	5.8	5.5	4.8	4.8	5.5	5.8	4.8	5.5	5.8
2	6.0	6.0	5.8	5.8	5.8	5.8	5.8	5.5	5.8	5.8	5.5	4.8	5.0	5.0	5.8	5.8	5.8	6.0	5.0	5.0	5.8	5.8	5.5	4.8	4.8	5.5	5.8	4.8	5.5	5.8
3	6.0	6.0	6.0	5.8	5.8	5.8	5.8	5.5	5.5	5.8	5.5	4.8	5.0	5.0	5.8	5.8	5.8	6.0	5.0	5.0	5.8	5.8	5.5	4.8	4.8	5.5	5.8	4.8	5.5	5.8
4	6.0	6.0	6.5	5.8	5.8	6.0	5.8	5.5	6.0	5.8	5.5	5.8	5.0	5.0	6.0	5.8	5.8	6.0	5.0	5.0	6.0	5.8	5.5	4.5	4.8	5.5	5.8	4.8	5.5	5.8
5	7.2	7.5	6.8	6.4	6.0	6.8	6.4	6.0	6.5	6.4	6.5	6.0	6.0	6.0	6.4	6.4	6.0	5.0	6.0	6.2	6.2	6.0	4.8	4.8	6.0	5.4	5.2	6.0	5.8	
6	8.0	7.5	7.0	7.4	6.5	7.0	6.8	7.0	6.8	7.2	7.0	6.8	7.0	6.2	6.0	7.0	6.8	6.8	5.4	6.5	6.5	7.0	6.0	5.8	5.0	7.5	5.9	5.4	6.8	6.0
7	9.0	9.0	8.3	8.6	8.5	8.5	7.4	8.0	8.0	8.0	9.3	8.5	8.0	8.0	7.5	6.8	7.4	7.5	7.8	5.5	6.5	7.6	8.0	5.1	6.8	8.0	6.2	5.7	7.3	6.5
8	9.6	8.5	10.0	9.4	9.2	9.8	8.0	9.0	9.8	9.4	9.5	9.2	9.0	8.5	8.8	9.0	8.0	8.8	8.4	9.0	7.0	8.4	8.5	8.0	8.0	8.0	7.5	6.0	8.0	8.0
9	10.6	9.0	9.8	10.0	10.0	9.8	8.6	9.5	10.0	10.0	10.0	9.2	10.0	7.5	9.0	9.5	8.6	9.5	8.4	9.5	8.0	8.0	8.5	8.0	8.4	8.3	8.0	8.0	8.0	8.0
10	10.6	11.0	11.0	10.4	11.0	10.4	8.6	10.0	11.0	11.0	11.0	10.0	10.0	9.0	9.0	11.0	8.8	10.0	8.6	9.3	8.0	9.0	9.5	8.5	9.0	9.0	8.5	8.0	8.5	8.5
11	10.5	12.0	11.5	11.8	11.0	11.0	8.5	10.0	11.0	11.5	11.5	10.0	11.0	8.0	4.0	11.0	8.5	9.3	9.0	9.0	8.5	9.2	9.0	9.0	9.0	9.0	9.1	7.5	8.8	9.5
12	11.0	11.4	11.0	11.0	10.4	11.0	8.0	10.0	11.0	11.2	11.2	10.5	10.5	8.0	9.0	10.1	7.5	9.3	8.8	9.0	8.5	9.0	9.0	8.3	9.0	9.0	9.0	7.5	8.8	9.5
13	10.5	11.0	11.0	10.0	10.0	9.5	7.8	10.0	10.8	10.8	10.1	10.0	10.5	7.4	9.0	10.0	8.0	9.3	7.0	9.0	8.5	8.8	9.0	8.5	8.8	9.0	9.2	7.5	9.0	9.0
14	10.5	11.0	11.0	10.0	10.0	9.5	7.5	10.0	10.5	10.8	10.2	10.0	10.0	7.0	9.0	9.8	7.6	9.3	8.4	9.0	8.5	8.5	9.0	8.5	9.0	9.0	9.0	7.5	9.0	9.0
15	10.1	10.8	11.0	10.0	10.0	9.5	7.5	10.0	10.3	10.8	10.0	10.0	10.0	7.0	9.0	9.8	7.0	9.3	8.4	9.0	8.0	8.8	9.0	8.5	8.0	9.2	9.0	7.1	9.0	9.5
16	10.8	10.8	11.0	10.0	10.0	9.5	7.5	9.0	11.0	11.5	10.0	10.0	10.0	7.0	9.5	9.8	7.6	9.1	8.4	9.0	7.5	8.8	9.0	8.5	9.2	9.0	9.0	7.1	9.0	9.5
17	10.8	10.8	10.5	10.2	10.0	9.5	7.5	10.0	10.3	11.2	10.0	10.0	10.0	7.8	9.5	9.6	8.0	9.0	8.4	10.0	7.5	8.8	9.0	9.0	9.0	8.5	9.0	7.1	9.0	9.5
18	10.8	11.2	10.8	11.0	10.0	10.0	8.8	10.5	11.0	11.5	10.7	10.0	10.2	8.0	9.3	9.0	9.0	10.0	9.0	10.0	7.5	9.0	9.8	9.0	9.0	9.0	9.0	7.5	9.0	9.5
19	11.0	11.2	10.8	10.0	10.0	10.0	10.0	10.1	10.4	11.3	10.5	10.0	10.3	9.2	10.0	9.5	9.0	9.0	9.8	9.5	8.0	9.5	8.8	8.4	9.5	9.5	9.0	9.0	9.5	9.0
20	10.5	9.8	10.0	10.0	10.0	9.1	9.8	9.5	9.6	10.0	10.8	9.0	9.0	9.0	9.2	8.2	8.0	8.4	9.0	9.0	9.0	9.0	8.0	7.2	8.5	8.8	9.6	8.5	8.5	8.8
21	9.5	9.5	9.0	9.0	8.8	9.0	8.3	9.0	9.0	9.0	8.5	8.0	9.1	7.0	8.0	8.0	7.8	7.4	7.0	8.0	8.0	7.0	7.5	6.6	7.5	7.5	8.4	7.0	7.5	8.5
22	9.5	7.8	8.6	8.0	7.5	7.0	7.0	7.1	7.0	7.5	8.0	7.0	7.0	6.5	7.0	7.2	6.8	6.6	6.5	8.5	7.4	6.5	7.0	5.6	7.0	7.4	7.0	6.0	6.8	7.8
23	7.0	3.6	6.8	6.0	7.0	7.4	6.0	8.0	6.4	6.0	7.5	5.4	6.0	6.6	6.4	6.4	6.0	6.2	6.0	6.0	7.0	6.0	6.5	4.8	6.5	6.0	6.6	6.0	6.8	6.8
24	5.5	7.6	5.8	5.5	6.5	5.8	6.0	6.0	5.8	5.5	4.5	5.0	5.5	5.0	5.8	5.8	5.5	6.0	5.5	6.8	5.8	6.0	6.0	4.8	6.0	6.0	6.8	6.0	6.4	6.4

2078 Chaitra Load(MW) per day																															
	Day	Day	Day	Day	Day	Day	Day	Day	Day	Day	Day	Day	Day	Day	Day	Day	Day	Day	Day	Day	Day	Day	Day	Day	Day	Day	Day	Day	Day	Day	Day
Hours	1	2	3	4	5	6	7	8	9	10	11	12	13	14	15	16	17	18	19	20	21	22	23	24	25	26	27	28	29	30	
1	5.8	5.5	5.0	5.0	4.8	4.8	4.8	4.8	4.4	4.8	5.5	5.0	5.0	5.5	5.5	4.8	4.5	4.5	4.8	4.5	4.8	7.8	4.5	5.8	4.4	5.5	5.8	5.8	5.5	4.8	
2	5.8	5.5	5.0	5.0	4.8	4.8	4.8	4.8	4.4	4.8	5.5	5.0	5.0	5.5	5.5	4.8	4.5	4.8	4.8	4.5	4.8	4.8	4.5	5.8	4.4	5.5	5.8	5.8	5.5	4.8	
3	5.8	5.5	5.0	5.0	4.8	4.8	4.8	4.8	4.4	4.8	5.5	5.0	5.0	5.5	5.5	4.8	4.5	5.6	4.8	4.5	5.0	7.8	4.5	5.8	4.4	5.5	5.8	5.8	5.5	4.8	
4	5.8	5.5	5.0	5.0	5.0	4.8	4.8	4.8	4.4	4.8	5.5	5.0	5.0	5.0	5.4	4.8	4.5	5.2	4.8	4.5	5.5	7.8	4.5	5.8	4.4	5.5	5.8	5.8	5.5	5.5	
5	6.2	6.0	5.1	5.4	5.5	5.0	5.2	5.2	4.4	5.0	6.0	5.5	6.0	5.5	5.8	5.0	5.0	5.5	5.4	5.5	6.0	5.4	6.0	5.4	5.0	5.5	6.0	6.4	6.0	5.8	
6	6.6	7.5	5.5	6.4	6.0	5.8	6.0	6.0	4.8	7.8	7.0	6.0	6.0	5.3	6.0	6.0	5.0	6.0	6.0	6.0	6.8	6.4	7.0	6.0	6.2	6.0	6.0	7.2	6.0	6.8	
7	7.0	8.0	6.0	7.0	6.8	7.2	8.0	8.0	6.0	7.8	7.5	7.0	7.2	5.5	7.0	7.4	8.0	6.8	7.0	7.0	7.5	7.2	8.0	7.8	8.0	6.0	6.8	8.0	8.0	7.5	
8	8.0	8.5	6.6	8.0	6.8	8.0	8.0	8.0	6.8	8.4	8.2	7.5	8.0	8.5	8.2	8.4	8.0	8.0	8.0	8.5	8.2	8.0	9.1	8.5	8.6	8.0	8.0	8.2	9.0	8.8	
9	8.0	8.5	7.0	8.2	7.0	8.0	9.0	8.5	7.2	8.5	8.5	8.0	9.0	9.0	9.0	9.0	9.2	8.5	7.0	9.0	8.8	9.8	8.8	8.8	9.7	8.0	8.2	8.4	9.5	8.8	
10	9.0	9.0	6.1	9.0	8.0	8.8	9.0	9.8	9.2	9.5	9.0	8.0	9.0	9.5	9.5	9.0	9.5	9.0	7.0	9.5	9.8	10.0	10.0	10.0	9.4	8.0	8.5	10.0	11.0	10.4	
11	9.8	9.0	6.1	4.5	7.8	9.3	9.8	9.8	10.0	10.0	9.4	8.0	9.2	9.4	10.0	9.9	9.8	9.0	8.0	9.5	11.0	10.8	10.0	10.5	10.5	8.4	9.0	10.5	10.4	11.0	
12	9.1	9.0	6.1	9.2	7.8	9.3	9.8	9.8	9.8	9.8	9.4	8.0	9.2	9.4	10.0	9.4	9.5	9.5	8.0	9.6	11.0	10.5	10.4	10.5	10.5	8.4	9.3	10.5	10.6	11.0	
13	9.1	8.0	6.0	9.5	7.8	9.3	9.8	8.0	10.0	9.8	9.0	8.0	9.2	9.4	10.0	9.6	9.5	9.5	8.2	9.6	11.0	10.5	10.4	10.0	10.5	8.4	9.5	10.0	10.6	11.0	
14	9.1	9.6	6.0	9.5	7.8	9.3	9.8	8.0	10.0	9.8	9.0	8.0	9.2	10.0	10.0	9.6	9.5	9.5	8.2	10.0	11.0	10.8	10.4	11.0	10.5	8.0	9.5	11.0	10.0	11.0	
15	9.8	9.6	6.0	9.5	7.8	9.3	10.0	8.4	10.0	10.0	9.2	8.0	9.8	10.0	10.0	9.8	9.8	9.5	8.2	10.0	11.0	10.8	10.4	11.0	10.5	8.0	9.5	11.0	11.0	11.0	
16	10.0	9.6	6.0	9.5	7.8	9.0	9.8	8.4	10.0	10.0	9.2	7.0	9.8	10.0	10.0	9.8	9.8	9.5	8.0	10.0	11.0	11.2	10.4	11.0	10.5	8.0	9.5	11.0	11.0	11.5	
17	9.2	9.0	6.8	9.0	7.8	9.3	9.8	8.4	10.0	10.0	9.0	8.0	9.8	9.5	10.0	9.8	9.8	9.5	8.0	9.4	11.0	10.8	10.1	10.5	10.0	8.4	9.0	10.4	11.0	11.5	
18	9.0	9.8	10.0	9.0	9.0	7.8	9.5	8.0	10.0	9.8	9.0	8.0	9.8	10.0	10.0	10.0	9.8	10.0	8.5	10.0	10.5	10.0	10.0	10.5	10.0	9.0	9.5	10.8	10.2	11.0	
19	9.3	9.1	8.0	9.8	9.0	9.2	9.3	8.5	9.6	9.8	10.0	9.0	10.0	9.3	10.0	10.0	10.0	9.0	9.5	9.8	10.4	10.0	10.8	10.7	11.0	9.0	9.6	11.0	10.8	11.0	
20	9.0	8.2	7.4	7.0	8.0	8.4	8.3	7.8	8.4	9.5	9.0	8.2	9.0	7.8	9.6	8.5	9.8	8.0	9.5	8.5	9.6	9.3	9.0	9.0	10.0	8.5	9.0	10.5	10.0	10.0	
21	7.5	8.0	6.8	7.5	7.6	8.0	7.8	5.4	7.6	8.5	8.0	7.0	8.5	7.1	7.6	8.0	8.5	6.6	9.0	8.0	8.0	9.0	8.5	8.4	9.0	7.8	7.6	10.0	8.3	9.0	
22	6.5	6.2	6.0	7.5	7.1	6.8	6.8	6.2	6.4	7.5	8.0	7.0	8.2	6.0	6.4	7.0	5.8	5.4	7.5	7.0	7.0	7.5	7.6	7.4	9.0	7.0	7.2	8.0	7.0	8.0	
23	5.5	5.8	5.0	6.0	6.8	5.2	5.0	6.0	5.4	7.0	7.5	6.0	7.5	6.6	5.2	6.5	7.0	4.8	6.0	7.5	6.0	9.0	7.0	7.4	9.0	7.8	6.4	7.5	6.8	6.0	
24	5.3	9.5	5.0	5.5	6.8	4.8	9.4	5.4	5.0	6.5	7.0	5.0	6.0	5.8	4.8	6.0	6.5	4.8	6.0	7.1	7.8	6.5	6.8	5.8	7.5	6.5	7.8	7.0	6.0	7.8	

2079 Baishakh Load(MW) per day																																	
	Day	Day	Day	Day	Day	Day	Day	Day	Day	Day	Day	Day	Day	Day	Day	Day	Day	Day	Day	Day	Day	Day	Day	Day	Day	Day	Day	Day	Day	Day	Day	Day	Day
Hours	1	2	3	4	5	6	7	8	9	10	11	12	13	14	15	16	17	18	19	20	21	22	23	24	25	26	27	28	29	30	31		
1	4.8	5.8	5.8	4.8	5.5	5.8	5.0	5.0	4.8	4.8	5.5	5.8	4.8	4.0	4.8	4.8	5.5	5.0	5.0	4.8	4.8	4.8	4.0	4.2	4.2	5.0	5.8	4.8	5.0	4.8	4.8		
2	4.8	5.8	5.8	4.8	5.5	5.8	5.0	5.0	4.8	4.8	5.5	5.8	4.8	4.0	4.8	4.8	5.5	5.0	5.0	4.8	4.8	4.8	4.0	4.2	4.2	5.0	5.8	4.8	5.0	4.8	4.8		
3	4.8	5.8	5.8	4.8	5.5	5.8	5.0	5.0	4.8	4.8	5.5	5.8	4.8	4.0	4.8	4.8	5.5	5.0	5.0	5.0	5.0	4.8	4.0	4.2	4.2	5.0	5.8	4.8	5.0	4.8	4.8		
4	4.8	5.8	5.8	4.8	5.5	5.0	5.0	5.0	5.0	4.8	5.5	5.0	4.8	4.0	4.8	4.8	5.5	5.3	5.0	5.0	5.0	4.8	4.0	5.0	4.2	5.0	5.8	4.8	5.0	4.8	4.8		
5	5.4	6.0	5.8	5.8	6.0	5.0	5.6	5.5	5.5	5.4	7.5	5.5	5.0	4.0	5.0	5.2	5.5	5.4	5.0	5.2	6.0	5.4	5.0	5.2	5.0	6.5	5.7	5.2	5.5	4.8	5.2		
6	6.2	6.3	6.0	6.0	7.0	5.2	6.4	7.0	6.0	6.4	8.0	6.0	6.0	5.0	5.0	5.4	6.0	5.6	5.4	6.0	7.0	6.2	5.0	5.8	5.4	6.0	6.0	5.6	6.0	5.0	5.8		
7	7.0	8.5	7.0	7.6	7.5	5.4	7.6	8.0	7.5	6.0	8.5	7.5	7.0	7.0	6.5	6.4	6.0	6.5	7.4	7.0	7.0	7.0	6.0	6.8	7.0	7.0	7.3	6.4	7.0	6.2	6.4		
8	7.2	8.5	8.0	8.4	8.0	8.8	8.0	8.5	8.5	7.0	8.5	8.2	8.2	6.0	7.1	6.4	7.5	6.8	8.0	7.8	9.0	8.0	6.4	7.8	7.8	8.0	7.8	8.2	8.0	6.5	7.0		
9	7.2	9.0	8.5	9.0	8.5	10.0	9.0	9.0	9.5	8.0	10.0	9.0	9.0	5.5	7.8	8.4	8.5	7.8	9.0	8.2	9.1	8.0	6.5	8.0	8.4	8.5	8.5	9.0	8.0	6.8	7.0		
10	5.2	10.0	8.0	9.8	9.0	11.0	9.4	10.0	10.3	8.2	10.2	10.0	10.0	9.0	10.2	9.2	8.5	7.8	9.8	8.6	9.5	8.0	9.0	8.0	9.0	9.5	9.5	9.0	9.0	7.0	8.0		
11	8.0	10.0	8.5	10.2	9.8	11.0	10.4	10.0	10.8	8.5	10.2	10.5	10.8	9.0	11.5	11.8	8.4	9.0	10.0	8.7	9.5	8.5	9.5	8.5	9.8	0.0	10.5	10.4	9.4	7.0	8.0		
12	8.0	10.4	8.5	10.2	9.8	11.0	10.4	10.4	10.0	8.5	10.2	10.5	11.0	9.0	11.0	11.5	7.0	9.0	10.0	8.4	9.5	8.5	9.4	8.5	10.0	10.0	10.5	10.0	9.4	6.5	8.0		
13	8.0	10.4	8.5	10.2	9.8	11.0	10.4	10.4	10.0	8.2	10.2	11.0	11.0	9.2	11.0	10.3	7.0	8.5	10.0	9.0	10.0	10.0	8.2	8.5	9.8	10.0	11.0	10.0	9.4	6.5	8.0		
14	8.0	11.0	8.5	10.2	10.2	11.0	10.4	10.4	10.0	8.5	10.2	11.0	10.0	9.2	11.5	10.2	7.2	8.5	10.0	9.0	10.0	10.0	9.8	8.0	9.8	10.0	11.0	10.0	8.8	6.5	8.0		
15	8.0	10.5	8.3	10.8	10.2	11.0	10.4	11.0	10.0	8.5	10.2	11.0	18.8	9.0	15.5	10.5	7.2	8.5	9.8	9.0	10.5	9.0	9.5	8.0	9.3	10.0	11.0	9.8	9.0	6.2	8.2		
16	8.0	10.4	9.0	10.8	11.0	10.4	10.6	11.0	10.0	8.5	10.2	11.0	18.0	9.0	10.0	10.5	7.8	9.0	9.1	9.0	10.5	10.8	9.5	7.5	9.8	10.0	10.5	9.8	9.0	7.0	8.2		
17	8.0	10.0	9.0	10.5	11.0	11.0	10.6	11.0	10.0	8.5	10.0	11.0	16.5	9.0	9.5	10.1	7.5	9.0	10.0	9.0	10.0	10.0	8.0	7.5	9.6	9.7	10.0	9.5	9.0	7.0	8.2		
18	8.0	11.0	9.2	10.0	10.2	11.0	10.0	10.5	10.0	9.5	10.0	10.5	8.0	9.0	9.5	10.0	8.0	9.0	9.8	9.0	10.0	10.0	9.5	6.0	9.5	9.5	10.0	9.0	9.0	7.4	8.2		
19	9.0	10.0	9.2	10.5	11.0	11.0	10.0	10.5	9.0	9.5	10.0	10.4	9.0	9.2	9.5	9.5	8.8	9.8	9.5	8.0	10.0	10.0	10.0	8.2	10.0	9.8	9.8	8.0	8.3	7.0	9.0		
20	8.6	9.6	9.2	9.3	10.2	11.0	9.5	10.0	8.4	9.3	9.8	10.2	8.0	8.5	8.0	8.5	8.2	9.0	9.0	7.8	8.4	9.5	9.8	8.0	9.5	8.1	9.0	7.5	8.0	7.0	9.0		
21	8.5	7.5	7.1	9.0	9.0	8.4	8.5	9.0	8.4	8.5	8.8	9.6	7.5	7.3	8.0	8.0	7.5	8.4	7.5	7.2	8.4	9.0	8.5	6.8	7.0	8.8	8.5	8.0	7.8	7.7	8.3		
22	8.0	7.0	6.2	7.5	7.8	8.4	7.0	7.5	7.6	7.5	7.0	9.0	6.0	7.3	7.0	7.0	7.0	2.4	6.8	8.5	8.0	7.0	7.0	5.8	6.0	7.5	7.0	6.0	6.2	5.6	8.0		
23	8.0	6.8	5.4	7.0	7.5	6.0	7.5	7.0	5.4	7.0	8.8	6.8	5.5	6.0	8.4	6.3	7.8	6.0	6.4	7.0	6.0	6.2	6.8	4.2	5.5	6.5	6.0	5.0	5.7	4.8	7.4		
24	7.5	6.0	4.8	7.5	7.5	8.8	5.5	0.5	4.8	6.5	5.8	5.0	5.0	6.0	4.8	6.0	6.5	5.0	6.0	5.0	4.8	5.4	6.5	5.0	5.0	6.5	7.8	5.0	5.5	4.2	6.0		

2079 Jestha Load(MW) per day																																		
	Day	Day	Day	Day	Day	Day	Day	Day	Day	Day	Day	Day	Day	Day	Day	Day	Day	Day	Day	Day	Day	Day	Day	Day	Day	Day	Day	Day	Day	Day	Day	Day	Day	Day
Hours	1	2	3	4	5	6	7	8	9	10	11	12	13	14	15	16	17	18	19	20	21	22	23	24	25	26	27	28	29	30	31			
1	4.5	5.8	4.8	5.0	4.8	4.8	4.5	4.8	4.8	5.0	9.8	4.8	4.5	3.8	3.8	4.0	5.0	4.8	4.5	4.8	4.8	4.5	5.8	4.6	5.5	4.8	4.8	4.5	5.8	4.8	4.0			
2	4.5	5.8	4.8	5.0	4.8	4.8	4.5	4.8	4.8	5.0	9.0	4.8	4.5	3.8	3.8	4.0	5.5	4.8	4.5	4.8	4.8	4.5	5.8	4.6	5.5	4.8	4.8	4.5	5.8	4.8	4.0			
3	4.5	5.8	4.8	5.0	4.8	4.8	4.5	5.0	4.8	5.0	9.8	4.8	4.5	4.0	4.0	4.0	5.5	4.8	4.5	5.0	4.8	4.5	5.8	4.6	5.5	4.8	4.8	4.5	5.8	4.8	4.0			
4	4.5	5.8	4.8	5.0	4.8	4.8	4.5	5.0	4.8	5.0	5.8	4.8	4.0	4.5	4.0	4.0	5.8	4.8	5.0	5.5	4.8	5.5	5.8	4.6	5.5	5.0	4.8	4.5	6.0	4.8	5.3			
5	5.0	5.8	5.0	5.5	5.0	5.6	5.0	5.6	5.2	5.0	5.8	5.0	5.5	4.6	4.5	5.5	6.5	5.4	7.0	5.6	4.2	6.0	5.0	5.5	6.0	5.5	5.2	5.0	6.5	5.6	6.0			
6	6.0	6.2	6.0	6.5	6.0	7.0	6.0	5.8	5.6	6.0	6.5	6.0	6.0	5.0	4.8	6.5	7.5	6.0	7.5	5.8	6.2	7.0	5.8	6.7	7.0	6.5	5.8	6.0	7.0	6.8	7.0			
7	7.0	7.0	7.5	8.0	7.8	8.0	7.0	7.0	6.4	7.0	7.2	8.0	8.0	5.8	6.0	8.0	8.8	7.0	8.0	6.8	7.0	8.0	7.0	8.0	8.0	7.2	6.8	7.0	7.5	7.8	8.0			
8	7.5	7.5	7.2	8.5	8.8	8.0	7.5	7.5	5.6	8.0	8.0	8.0	8.0	6.5	8.0	8.5	8.5	8.5	9.0	8.0	8.0	8.0	6.8	9.6	9.0	8.8	5.2	8.0	9.0	8.6	9.0			
9	8.0	8.0	9.0	9.0	9.5	8.0	8.0	7.8	8.6	9.0	9.0	8.8	9.0	6.8	8.5	10.0	10.0	8.5	11.0	10.0	8.2	8.5	8.0	9.6	9.8	9.0	10.0	8.5	9.0	9.2	9.5			
10	8.5	8.5	10.0	10.0	10.8	10.0	8.5	8.0	10.0	9.5	9.8	9.4	9.3	7.0	8.6	10.0	10.0	8.5	11.0	11.0	8.2	9.5	8.8	9.6	11.0	9.6	10.0	9.0	9.8	11.0	11.0			
11	9.0	8.5	10.8	10.4	10.0	11.0	8.3	9.0	8.8	10.0	10.0	10.0	10.0	7.0	8.3	11.0	10.0	0.0	11.0	11.0	9.2	10.0	11.0	10.5	11.4	11.0	11.2	9.0	10.0	11.0	11.0			
12	9.0	9.3	10.8	10.4	10.0	11.0	8.0	9.0	10.3	10.0	10.0	10.0	10.0	7.0	9.0	10.5	11.0	11.0	11.0	11.0	9.0	10.0	11.0	11.0	11.4	10.8	11.2	9.0	10.0	0.0	11.2			
13	8.4	9.3	10.5	10.5	11.0	11.0	8.0	8.3	10.3	10.0	10.0	10.0	10.2	7.0	8.8	11.0	11.0	11.8	11.0	11.0	8.5	9.4	11.0	11.2	10.0	11.0	11.5	8.6	10.0	13.0	11.0			
14	8.4	9.5	10.5	10.4	11.0	11.0	8.0	9.4	10.0	10.0	10.0	10.0	10.2	5.0	8.8	11.0	11.0	11.3	11.0	11.0	8.5	9.4	11.0	11.5	10.6	11.0	11.2	9.4	10.0	12.5	11.4			
15	8.4	9.8	12.0	11.5	11.0	11.0	8.0	9.5	10.0	10.0	10.0	9.8	10.2	8.0	9.2	11.0	10.0	11.3	11.0	11.0	8.8	9.4	12.0	11.5	10.6	11.0	11.2	9.0	11.0	12.5	12.4			
16	9.0	9.5	12.0	11.5	11.0	11.0	8.0	9.5	10.0	10.2	10.0	10.0	10.4	8.0	9.0	11.0	10.0	11.3	11.0	11.0	8.8	9.4	12.0	11.5	10.4	10.0	11.8	9.0	11.0	12.5	12.6			
17	9.0	9.3	12.0	11.5	11.0	11.2	8.0	9.5	10.0	10.2	10.0	9.5	10.4	8.0	9.2	10.0	10.2	11.0	11.0	11.0	8.8	9.6	0.0	11.0	10.2	10.0	11.2	9.0	10.5	12.5	12.5			
18	9.5	9.2	9.6	10.5	10.2	11.0	8.3	9.0	9.5	10.0	9.3	9.0	10.0	8.0	9.5	10.0	9.4	10.5	10.5	11.0	9.0	9.5	11.0	10.5	10.0	10.5	10.0	9.8	10.0	11.8	11.8			
19	9.0	8.2	9.0	10.5	10.0	8.0	9.0	9.5	0.0	9.8	9.5	8.5	10.0	8.6	10.0	10.0	9.0	10.3	10.8	11.0	9.5	10.0	10.0	10.0	10.0	10.2	11.0	10.5	10.2	11.0	11.0			
20	9.0	8.0	10.0	4.5	7.2	7.5	9.5	8.6	9.0	10.0	8.0	8.3	10.5	9.5	9.0	9.8	9.4	10.0	9.8	9.4	9.5	7.1	9.0	9.0	9.8	9.3	10.0	10.5	10.2	11.0	10.0			
21	8.0	6.2	8.3	5.4	6.4	7.0	8.5	8.0	8.0	9.5	7.0	8.0	9.5	9.0	9.0	8.8	8.0	9.0	4.5	9.2	8.5	7.0	8.0	9.0	8.0	9.0	9.0	9.0	9.4	9.0	9.0			
22	6.8	6.0	7.5	4.0	5.4	7.0	7.8	7.0	7.0	8.2	6.0	7.5	9.0	8.8	8.5	7.4	6.4	8.0	7.8	8.0	7.5	5.2	6.8	8.0	7.5	9.0	8.0	8.0	9.0	8.5	8.0			
23	6.4	5.8	7.5	4.0	4.8	6.3	7.0	6.0	6.5	7.0	4.8	6.5	8.5	8.5	7.3	6.8	5.0	7.0	7.0	5.6	7.0	7.0	5.4	7.3	0.0	6.2	7.5	7.8	7.0	8.0	7.5			
24	5.8	5.8	6.5	5.0	4.4	6.0	5.8	5.8	6.0	6.5	4.8	6.0	8.0	4.0	6.5	6.8	4.8	6.5	7.0	1.8	6.0	6.5	4.8	7.0	5.5	5.2	5.5	7.5	4.8	7.5	7.0			

