

Socio-economic Impact of Shivapuri National Park on Local Community: A Case Study of Budhanilkantha Area

By

**Laxmi Karki
Regd. No. 5-1-283-39-96
Exam Roll No: 3228**

**A thesis submitted in partial fulfillment of the requirements for the degree of
Master of Arts in Rural Development**

**Central Department of Rural Development
Faculty of Humanities and Social Sciences
Tribhuvan University, Kirtipur
Kathmandu, Nepal.**

November 2006

Recommendation Letter

This thesis entitled “Socio-economic Impact of Shivapuri National Park on Local Community: A Case Study of Budhanilkantha Area,” has been prepared by Ms. Laxmi Karki, under my direct supervision, in partial fulfillment of the requirements for the Master of Arts degree in Rural Development. I, therefore, recommend for its evaluation and acceptance by the thesis evaluation committee.

Dr. Ek Raj Ojha
Research Supervisor

Approval Letter

This is to certify that the thesis, entitled “Socio-economic Impact of Shivapuri National Park on Local Community: A Case Study of Budhanilkantha Area,” submitted by Ms.Laxmi Karki, has been approved by the Department in the prescribed format of the Faculty of Humanities and Social Sciences.

Evaluation Committee

Prof. Dr. Pradeep Kumar Khadka
(Head of the Department)

Dr. Ek Raj Ojha
Research Supervisor

External Examiner

Abstract

Shivapuri National Park was established in 2002. Earlier, Shivapuri was the main source of fuelwood, fodder and timber for the local people. In 1975, Government of Nepal tried to check the problem of deterioration of Shivapuri ecosystem and established development project under the guidance and supervision of Shivapuri Development Board. Again the area was gazetted as Shivapuri Watershed and Wildlife Reserve (SWWR) in 1983. In February 2002, the reserve was declared as National Park. Hence, the practices of local people for years and their access to natural resources of Shivapuri have been undermined.

Keeping in mind the above-mentioned situation, Budhanilkantha area inside the Shivapuri National Park was selected for the study. The general objective of the study is to assess the socio-economic impact of the Shivapuri National Park on the livelihoods of the people living nearby. The specific objectives of the study are to examine the socio-economic condition of the local people, to estimate the demand and supply of firewood in Budhanilkantha Area, to find out the components of conflicts between the local people and National park. The descriptive research design has been adopted. Primary and secondary data have been equally used. A sample of 103 households has been taken using the purposive sampling method under non-probability sampling design. A questionnaire using both closed and open-ended types of question was prepared and administered in Nepali language.

It has been concluded that the majority (93%) of the respondents are satisfied with the establishment of the Shivapuri National Park but the local people living in and around the Shivapuri National Park have no legal access to all available and required natural resources which are although in good condition and in reasonable distance for resource collection.

Livestock rearing is one of the main sources of income of the local people. Although, fodder/grass collection and grazing have been banned by the Park, Sixty- two percent of the respondents still collect fodder/grass from the farm land. The local people's demand for firewood for the energy purpose is not fulfilled by the Park and sometimes the people steal required the firewood and the fodder/grass from the Park.

The better way to solve the above problem could be the creation of buffer zone, which could provide resources to the local people and help minimize the present resource related conflict. Moreover, the local people should be involved in all processes of the conservation strategy.

Acknowledgements

I am grateful to my supervisor, Dr. Ek Raj Ojha, a faculty member at the Central Department of Rural Development, T.U., Kritipur, for his valuable advice, support and encouragement without which it could have been difficult for me to complete this thesis.

I gratefully acknowledge my thanks to Prof. Dr. Pradeep Kumar Khadka, Head of the Central Department of Rural Development, Mr. Suman Baskota, Lecturer of Rural Development, and Mr. Tulasi Sharan Sigdel, Assistance Lecturer of Rural Development, T.U., for their valuable guidance, suggestion and support.

I am very much indebted and would like to dedicate this work to my parents, who always nurtured and supported me with their encouragement including Master's degree I am now going to receive.

I owe a debt of gratitude to my brother T.B. Karki, for being my source of encouragement and invaluable support. I am also thankful to my Brother Rupesh Khadka and Sister Anita Karki to complete this thesis.

My special thanks go to all my friends: Roshani Maharajan, Tejaswi Narayan Vaidya, Shree Krishna Shrestha, Shyam Thapa, Janak Raj Pathak, Sagar Shrestha, Sharmila Ranabhat, Govind Singh, Pallavi Dahal, Jubin Parajuli, Sanjay Acharya, Bikash Kandel, Ambir Balami, Rishi Ram Bimali, Santosh Sharma and Bijay Raj Pant for their valuable support without which I could not be successful to complete my thesis.

I am indebted to all the respondents who responded to my questions and to all known and unknown authors whose works were used to get insights without which it could have been difficult to complete this task.

I would like to thank the entire library and administrative staff T.U. for their continuous support to complete this work.

Last but not the least, Mr. Kumar Karki, MD of Landmark Educational Consultancy Center (P) Ltd., deserves thanks for his continuous support in providing computer facility.

Laxmi Karki

October, 2006

Table of Contents

	Page
Recommendation Letter	i
Approval Letter	ii
Abstract	iii
Acknowledgements	iv
List of Tables	viii
List of Figures and Box	ix
Abbreviations and Acronyms	x
1. Introduction	1-5
1.1 General Background and the Concept of National Park	1
1.2 Statement of Problem	2
1.3 Significance of the Study	3
1.4 Objectives of the Study	3
1.5 Conceptual Framework	4
1.6 Limitations of the Study	5
2. Literature Review	6-27
2.1 Terms and Concepts	6
2.2 Forests	8
2.2.1 National Forestry Plan	8
2.2.2 Community Forestry	11
2.2.3 Effective Afforestation	11
2.2.4 Forests in Kathmandu Valley	11
2.2.5 Distribution of Forests	12
2.3 Issue and Context	14
2.4 Status of wildlife Conservation in Nepal	17
2.5 Hindus Speculation of Wildlife in Pre-history	17
2.6 Conservation	17
2.7 Declaration of Protected Areas and Sustainable Management	18
2.8 Sustainable Management Problem: Park and People Conflict	21
2.9 Concepts for Sustainable Protection against Natural Hazards	22
2.10 The Forestry Sector	23
2.11 Review of the Related Studies	26
3. Research Methodology	28-30
3.1 The Shivapuri National Park	28
3.2 Rationale of the Selection of Study Area	29
3.3 Research Design	29
3.4 Nature and Sources of Data	29
3.5 Sampling Procedure	29

3.6	Techniques and tools of data collection	30
3.6.1	Techniques	30
3.6.1.1	Household survey	30
3.6.1.2	Observation	30
3.6.1.3	Key Informant Interview	30
3.6.1.4	Focus Group Discussion	30
3.6.2	Tools	30
3.7	Data Processing and Analysis	30
4.	The Study Area	31-34
4.1	Short Profile of Budhanilkantha Area	31
4.2	Physical Features	31
4.3	Vegetation	32
4.4	Fauna and Flora	32
4.5	Water Resources	32
4.6	Culture and Religion	32
4.7	Tourist Attraction	33
4.8	Watershed	33
4.9	Watershed Management	33
4.10	Fuelwood Management	33
4.11	Park's Regulations	34
5.	Data Presentation and Analysis	35-61
5.1	Demographic and Socio-economic Conditions	35
5.1.1	Gender of the Respondents	35
5.1.2	Family Structure and Size	36
5.1.3	Religion of Respondents	37
5.1.4	Education	38
5.1.5	Occupation of the Respondents	39
5.1.6	Land holding	40
5.1.7	Income Source	41
5.1.8	Livestock/ Animal Husbandry	42
5.2	Natural Resources Accessibility	44
5.2.1	Collection of Fodder\Grass	44
5.2.2	Local Forest before Establishment of National Park	45
5.2.3	Energy Sources	46
5.2.4	Wood Used for Cooking Purpose per Day	47
5.2.5	Collection of Firewood	47
5.2.6	Convenient to Get Firewood after Establishment of SNP	48
5.2.7	Selling Firewood\ Timber in the Market	49
5.3	Perception of Respondents about the National Park	50
5.3.1	Living Condition Improved after the Establishment of SNP	50
5.3.2	Tourist Amenities	51

5.3.3	Local Economy after Establishment of SNP	52
5.3.4	Income Level after Establishment of SNP	53
5.3.5	Satisfied with Present Condition of SNP	54
5.3.6	Firewood Fulfilled by the Park	55
5.3.7	About the Park's Rules	56
5.4	Areas of Conflict	57
5.4.1	Crops Damaged by Wild Animal	57
5.4.2	Grazing Problem	58
5.4.3	Opinion of the Respondents Regarding to Close the National Park	59
5.4.4	Park's Rule	60
6.	Summary, Conclusion and Recommendations	62-65
6.1	Summary	62
6.2	Conclusion	64
6.3	Recommendations	64
6.3.1	Recommendations for Planning	64
6.3.2	Recommendations for Further Research	65
Reference		66-70
Appendixes		
Appendix - I	Photographs	71-73
Appendix - II	Questionnaire	74-76

List of Tables

		Page
Table 2.1	Poverty, Pollution and Protected Areas of Some Countries	10
Table 2.2	Total Revenue from Forest Products, FY, 2057\2058 to 2060\2061	12
Table 2.3	Protected Areas of Nepal's National Parks, Wildlife Reserves, Hunting Reserves, Conservation Areas and Buffer Zone	13
Table 2.4	Forest user Group National Level Database, (Till 9 March, 2005)	14
Table 2.5	Status of Protected Areas of Nepal	20
Table 2.6	Distribution of Nepal's Natural Forests (ha)	24
Table 5.1	Distribution of Respondents by Gender	35
Table 5.2	Distribution of Respondents by Family Size	36
Table 5.3	Ethnic Composition of the Respondents	37
Table 5.4	Educational Attainment of Respondents	38
Table 5.5	Distribution of the Respondents by Occupation	39
Table 5.6	Distribution of Respondents by the Land holding Size	40
Table 5.7	Distribution of Respondents by their Monthly Income (Rs)	41
Table 5.8	Distribution of Respondents by Livestock Keeping	43
Table 5.9	Distribution of Respondents by Collection of Fodder\Grass	44
Table 5.10	Situation of Local Forest	45
Table 5.11	Fuel Used for Energy Purpose	46
Table 5.12	Respondents Used Wood for Cooking Purpose	47
Table 5.13	Collection of Firewood per Day from Park	48
Table 5.14	Firewood after Establishment of SNP	49
Table 5.15	Respondents Selling Firewood in the Market	50
Table 5.16	Distribution of Respondents about the Living Condition	51
Table 5.17	Increased in Tourists Number after the Establishment of Park	52
Table 5.18	Respondents' Perception about the Local Economy	53
Table 5.19	Respondents' Level of Income after Establishment of SNP	53
Table 5.20	Respondents Level of Satisfaction with Park	54
Table 5.21	Firewood Fulfilled by the Park	55
Table 5.22	Respondents Know the Park's Rules	56
Table 5.23	Crops Damaged by the Wild animals	57
Table 5.24	Problem Faced by the Respondents	58
Table 5.25	Respondents' Opinion to Close the National Park	59
Table 5.26	Respondents Disobey of the Park's Rule	60

Abbreviations and Acronyms

BZ	:	Buffer Zone
BZUG	:	Buffer zone users group
CBOs	:	Community Based Organization
CBS	:	Central Bureau of statistics
CFUG	:	Community Based Forest Users Group
DFID	:	UK Department for International Development
DFO	:	District Forest Office
DNPWC	:	Department of National Parks and Wildlife Conservation
FAO	:	Food and Agriculture Organization of UN
FINNIDA	:	Finnish International Development Agency
FSP	:	Forest Sector Policy
GOV	:	Government of Nepal
HHs	:	Household
ICIMOD	:	International Centre for Integrated Mountain Development
INGOs	:	International Non Governmental Organizations
LPG	:	Liquid Petroleum Gas
IUCN	:	International Union for Nature Conservation
MFSC/MoFSC	:	Ministry of Forest and Soil Conservation
MPFS	:	Master Plan for the Forestry Sector
NGOs	:	Non Government Organizations
NRs/ Rs	:	Nepalese Rupees
NTFPs	:	Non Timber Forest Products
NWFPs	:	Non Wood Forest Products
RBNP	:	Royal Bardia National Park
RCNP	:	Royal Chitwan National Park
SNV	:	Netherlands Development Project
SNP	:	Shivapuri National Park
SP	:	Species
SWWR	:	Shivapuri Watershed Wildlife Reserve
T.U.	:	Tribhuvan University
UG	:	Users Group
UNDP	:	United Nation Development Programme
VDC	:	Village Development Committee
WWF	:	World Wildlife Fund

Chapter - One

INTRODUCTION

1.1 General Background

The earliest model of today's protected areas, e.g. national parks and strict nature reserves originated within the traditions of mid-to-late industrial civilization. As a reaction to destruction of nature caused by industrial development, these early models, attempted to protected areas, were established in non-industrial and industrializing countries of the world during the early parts of the 20th century. Tradition as it is in non-industrialized countries achieved a balance between resource use and conservation through a complex array of social practices guided by myths and legends. The success of model of protected area management advocating a strict legal separation of resource use and conservation within the traditional and cultural context of industrialized countries was bound to be time limited.

Nepal started impressive initiative to protect its unique biodiversity since 1973 by promulgating the National Park and Wildlife Reserve Conservation Act 1972, (2029 B.S.) parallel with the establishment of Royal Chitwan National Park as the first protected area of the country. At present, under the Department of National Parks and Wildlife Conservation an authorized government organization to the parks and protected areas in Nepal, have nine National Parks, three Wildlife Reserves, three Conservation Areas and one Hunting Reserve covering a total area of 26,696 square kilometer or 18.14 percent of the country total land. Experience drawn from the protected area management has shown that the sustainable development for long- run survival of the protected area will be very difficult without the cooperation of people living around it. As such, participatory management concept has been introduced by forming the protected areas management through the promulgation of the Buffer Zone Act 1992 with subsequent Regulation in 1996. The Act clearly advocates that 30-50% of the revenue generated from each protected area should be spent on the buffer zones of the respective protected areas for Buffer Zone community development through user group management approach. Currently, 5 National Parks have Buffer Zones, which cover 3432sq.km area of Nepal. They are operating under the Buffer Zones Management Guidelines 1999. The Shivapuri National Park, which adjoining the present study area, was established in 1975.

The Concept of National Park

In the context of Nepal, according to DNPWC Act 2029 B.S, National Park means an area set aside for conservation, management and utilization of animals, vegetation and landscape together with the natural environment.

A National Park is a relatively large area where;

- One or several ecosystems are not materially altered by human exploitation and occupation, where plant and animal species, geomorphological sites and habitats are of special scientific educative and recreative interest, or which contains a natural landscape of great beauty;
- Competent authority of the country has taken steps to prevent or eliminate as soon as possible, the exploitation or occupation in the whole area and to enforce effectively the respect of ecological, geomorphological or aesthetic features which have led to its establishment; and
- Where visitors are allowed to enter, under special conditions for the inspirational, educative, cultural and recreative purposes.

Hence, it is now a global concept that the national parks are legally designated areas in where natural or cultural phenomena of national significance are protected from the exploitation for private gains so that they can be enjoyed by the public.

1.2 Statement of the Problem

The subsistence economy of the local people requires even more accessibility to the resources from the nearby forests. Resources required for the subsistence economy include seasonal access to the forests for fodder and firewood, edible fruits and vegetables, medicinal plants or their parts, fishing, hunting and collection of young animals for meats and eggs, and the grazing of livestock in the forests and grasslands. Most of the local forests are now protected inside the park, thus conflicts with people over resources are inevitable. Allowing people in harvesting thatch grasses, banding materials, tall tress and some firewood to fulfill their subsistence needs provide only a partial answer. The whole issue of the subsistence requirements must be examined in a more holistic way and policies that are finely simplified between local people's subsistence and the long-term conservation goals of the National Park should be developed and implemented. This approach includes socio-economic condition of the local people and strengthening the institutional capabilities (Nepal and Weber, 1993).

1.3 Significance of the Study

The following are the important points about the explanation of the research study area.

- Socio-economic condition is the important parameter in order to analyze their life standard and relation with Shivapuri National Park.
- Firewood is increasing problem in all over the world due to the actual shortage of fossil fuel.
- If firewood is only used for cooking and continues the practice in near future it will create problems for environment as well as health.
- Due to lack of education most of the local people have no positive idea about the environment, biodiversity and protection of SNP.
- There is no clear understanding and proper communication between the SNP and local people.
- Livestock is the source of income and they are dependent on the park resources.

1.4 Objectives of the Study

The main objective of the research is to assess the socio-economic impact of the Shivapuri National Park on the livelihoods of the people living nearby. The specific objectives are:

1. To examine the socio-economic condition of the local people.
2. To estimate the demand and supply of firewood in Budhanilkantha Area.
3. To find out the component of conflicts between the local people and National Park.

1.5 Conceptual Framework

To access the impact of park area upon the livelihood of local people, the conceptual framework has been designed as follows (figure 1.1). The conceptual framework based on DFID.

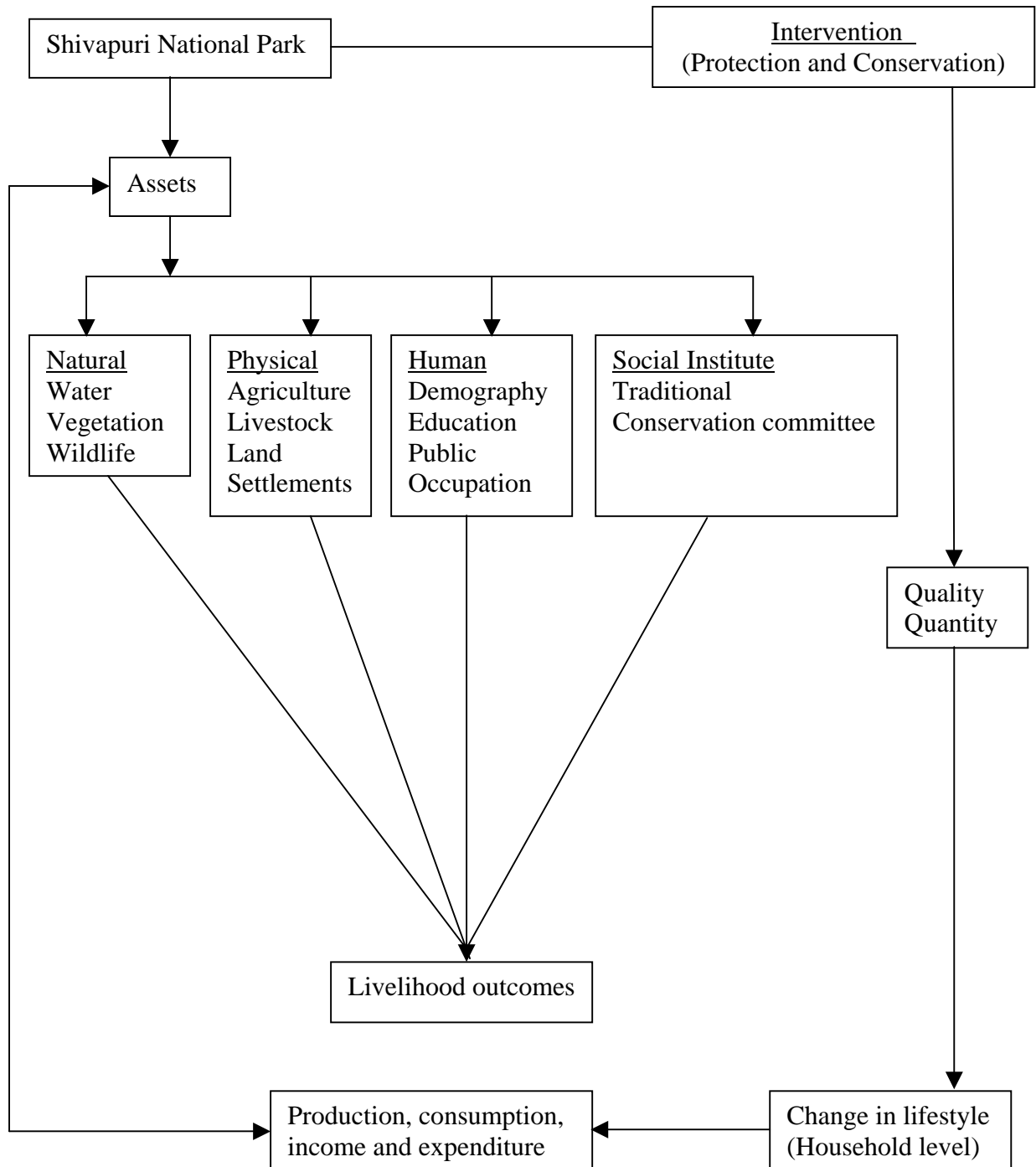

1.6 Limitation of the Study

1. The findings of the study are limited in the selected sample units.
2. Since, this study is concern with the people living within and around Shivapuri National Park; it may not represent the relationship between the people and parks in other places of the country.
3. The variables in present study are operationally defined in view of the general characteristics of the study and therefore they are applicable only to the present context.
4. Other constraints of this study include limited time for field survey and resource limitation.

Chapter - Two

LITERATURE REVIEW

2.1 Terms and Concepts

Biodiversity: The variety of life in all its forms, levels and combinations. This includes ecosystem diversity, species diversity and genetic diversity

Buffer Zone: An area on the edge of a protected area that has land use controls that allow only activities compatible with the objectives of the protected area; appropriate activities might include tourism, forestry, and agroforestry. The objective of such zone is to give added protection to the protected area, and to compensate local people for the loss of access to the biodiversity resources of the reserve.

Conservation: The management of human use of organisms or ecosystems to ensure such use is sustainable. Besides sustainable use, conservation includes protection, maintenance, rehabilitation, restoration and enhancement of populations and ecosystems

Ecodevelopment: Economic and social development being undertaken in a manner, which is ecologically sensitive, that is compatible with and takes advantage of natural systems.

Ecological Sustainability: A society is ecologically sustainable if it (i) conserves ecological life-support systems and biodiversity, (ii) ensures that uses of renewable resources are sustainable and minimizes the depletion of non-renewable resources, and (iii) keeps within the carrying capacity of supporting ecosystems.

Ecosystem: The totality of factors of all kinds that make up a particular environment; the complex of biotic community and its abiotic, physical environment, functioning as an ecological unit in nature.

Ecotone: A transition area between two adjacent ecological communities (as the park and the agricultural area in its vicinity) usually exhibiting competition between organisms common to both.

Ecotourism: Traveling to and visiting relatively undisturbed or uncontaminated natural areas with the specific purpose of studying, admiring and enjoying the

scenery, its flora and faunas, as well as existing cultural manifestations found in these areas.

Farmer: One who resides in a village and cultivates the farmland that he holds as the major source of living.

Household: A group of individuals related to each other by blood, marriage, or co-operation, living in one and the same residential unit, contributing to and/ or sharing the group's material and financial resources, and partaking of meals prepared at the same fire place or stove, or from one kitchen with a single fire place or stove.

Indigenous: Having originated in and being produced, growing or living naturally in a particular region or environment; native.

Local People: Individuals living within the same political boundary of the study area.

National Parks: Relatively large area of national or international significance that are not to be materially altered by human beings. Access is controlled, but visitors are encouraged to use the areas for recreation and study.

Protected Area: Any area of land that is, subject to legal measures limiting human use of its plants and animals. Protected areas include national parks, game reserves, multiple-use areas, and biosphere reserves among others.

Sustainable Development: The ability to maintain the production of goods and services from system overtime. In this way, present day needs are met without foreclosing future options for meeting future needs. It is associated with the scale and style of resources use over time.

World Heritage Site: An area protected for its natural features for which it is considered to be of outstanding universal importance. Incorporated into a select list of the worlds, unique natural and cultural sites nominated by countries that are partly to the World Heritage Convention.

Zoning: Land use zoning; the demarcation of a planning are by ordinance into zones and the establishment of regulations to govern their use.

2.2 Forests

Forests come to existence as the result of natural growth or of the afforestation made by man. Forests are very much exploited for forest products. A forest is aptly described as a plant society of arborescent and shrub species both of which are of economic importance. Forests greatly affect the climate, the river system, the conservation of soil and the ecology existing between trees and animals.

Thus, the main purpose behind developing the forests of Nepal lies in the need for maintaining an ecological balance so as to meet the average requirement of timber, fuel-wood, fodder, minor forest products, soil protection, water conservation, wildlife recreation and aesthetic values.

Since time immemorial, Nepal has been very rich in forests. There is an old Nepalese proverb saying '*Hariyo ban Nepal ko dhan*' which means green forests are the wealth of Nepal. It was in earlier days that the Terai area of Nepal was full of forests and there the malarious climate prevailed.

The forests of Nepal are greatly depleted mainly owing to one factor, as fuel wood is the single biggest item with 86.7 percentage of the total energy consumption. As a result of overdependence on a single resource the forests resources are fastly dwindling.

2.2.1 National Forestry Plan

Bajracharya (1977) has very concisely described the salient features of National forestry plan on the basis of an integrative outlook on Nepalese Forest Eco-system. Besides, two mimeographed references published by the Ministry of Forest, H.M.G., are also available under the caption "*People Participation in Forest Protection and Production*" and "*New Revolution in Forest Management Part I, Part II 1978*". These two references lay down the rules, regulations and conditions for the new National Forestry Plan.

The National Forestry Plan recognizes the value of forests for the following five reasons.

- To have a renewable resource for producing a number of goods and services.
- To help conserve soil and water.
- To create an environment of scenic beauty with appropriate aesthetic value.
- To provide a medium for recycling wastes.
- To ensure a habitat for preserving faunal and floral wealth.

The National forestry plan has considered 4 types of forests of Nepal.

1. Terai and Bhabar forests.
2. Doon and Inner Terai Forests.
3. Midland Forests.
4. Inner Himalayan Forests.

These 4 types of forests have been recognized as typical for different zones, suited to the skills and attitudes required by particular ethnic groups of people towards a certain kind of forest and forestry and catering for different needs for management in various geographical zones.

2.2.2 Community Forestry

Recently (in 1979) the Government has introduced a scheme of community forest development project to improve and reestablish forests so as to increase the supply of fuel wood, fodder and timber for construction. Subsidiary aims will be to check land erosion, ensure village spring-water supplies and foster the spirit of self-help among villages. The project will cover a five-year period beginning from May 1980 which will be the first time slice of a twenty year community forestry program but in view of urgency for reforestation and the need for immediate pre-project investment. This will be the first project of its kind to be implemented in Nepal jointly by His Majesty's Government, UNDP and FAO. Finance for the project will be provided by the World Bank and His Majesty's Government and technical assistance jointly by UNDP and FAO. About 25 million US dollars are expected to be spent in the first five year phase of the project. By the end of its first five year phase a total of seventeen forest divisions and three hundred and forty village panchayats will be included in the community forestry development project. Under the project, panchayat forests will be established in 11,750 hectares of land and panchayat protected forests in 37,400 hectares of land.

i) Firewood Supply

Firewood is the main product determining the well-being of women and has to be supplied from the local forests. Malla (2000) reported that people do not have sufficient firewood from community forests irrespective of the resources. In some groups firewood is not distributed annually and in a few groups for many years despite the users' desperate need and the existence of harvestable stock in the forests. Forest management is timber-oriented irrespective of demand, and the management principle is positive selection for timber and negative selection for firewood. None of the groups have firewood specific plots. Thus the firewood supply is going to decline.

ii) Forest land-use for Firewood

Firewood was the main source of cooking and heating energy for all countries when they had no alternative sources of energy such as coal, kerosene, gas and electricity. It is also interesting to note that the firewood use is far more environmentally friendly than fossil fuel. Firewood is a good with poorly elastic demand and the availability of the product determines the consumption behavior of households and workload for women. The cash income of households does not impact firewood consumption behaviour. Firewood supply could provide only seasonal employment for people living close to town or transportation facility where firewood is produced sufficiently. Locally produced firewood is far more economical than electricity or imported fossil fuel for most rural people of the world.

iii) Economic Impacts of Protected Areas

According to policies and community practices, it could be argued that all community forests are a form of protected areas in Nepal. In addition, more conservative protection activities and management are expanded to productive forests and even on arable lands. Table 2.1 depicts poverty, pollution and national land area contribution for environment conservation of selected countries.

Table 2.1 Poverty, Pollution and Protected Areas of Some Countries

Country	Access to nutrition and health service		Population % below income		Share of environment conservation resources		Carbon dioxide emission	
	Under-nourished people	Population with access to essential drug (%)	\$ 1/day	\$2/day	Total forest area (%)	Protected area (%)	Per capita (M. ton)	Share of world total
Bangladesh	33	50-79	29.1	77.8	10.2	0.7	0.2	0.1
Bhutan	-	80-94	-	-	64.2	21.4	0.2	..
China	9	80-94	18.8	52.6	17.5	7.1	2.5	12.8
India	23	0-49	44.2	86.2	21.6	4.5	1.1	4.4
Nepal	23	0-49	37.7	82.5	27.3	19**	0.1	...
Pakistan	18	50-79	31	84.6	3.2	4.7	0.7	0.4
SriLanka	23	95-100	6.6	45.4	30	13.3	0.4	...
Australia	0	95-100	0	0	20.6	13.6	17.9	1.4
Canada	0	95-100	0	0	26.5	9.6	15.3	1.9
USA	0	95-100	0	0	24.7	21.2	19.9	22.5
Japan	0	95-100	0	0	66.1	6.9	9	4.7
Denmark	0	95-100	0	0	10.7	32	10.1	0.2
Germany	0	95-100	0	0	30.7	27	10.1	3.4
Switzerland	0	95-100	0	0	30.31	18	5.7	0.2
UK	0	95-100	0	0	11.6	20.4	9.2	2.2

Note: Including all protected forest, wetland, marine and non-forested areas. The inflated figures are due to including marine area or forest areas used in sustainable commercial timber harvesting such as the USA.

Forest area includes only timber forest with above 10 percent crown cover and potential to develop into timber forest in future as defined by the Global Forest Resource Assessment, 2000.

Nepal has increased additional (about 1 percent) in 2004 and planned to increase other in near future

Pollution, nutrition, health and income data are from UN Human Development Report 2002, and forest and protected area from UN Statistics 2004.

These comparative statistics indicate that Nepal has set aside more land for conservation than other countries and neglected utilization of valuable resources for poverty alleviation and nation building.

2.2.3 Effective Afforestation

Campbell (1978) has suggested a scheme for effective afforestation. Experience shows that saplings planted during the early monsoon months grow much better than those planted in November\December. It is also a wise thing to plant 10 trees, which survive to maturity rather than 20 trees and three-fourths of which die due to neglect. This happens in various programs arranged to celebrate various important national occasions.

2.2.4 Forests in Kathmandu Valley

Following species are found in Kathmandu valley:

1. *Pinus roxburghii*(Chirpine)
2. *Alnus nepalensis*(Utis)
3. *Quercus* sp.
4. *Schima wallichii*
5. *Rhododendron* sp.

Fleming (1973) has described the general forest in the midland Nepal. He has given an example of forests of Godavari. According to him, there are various exotic and endemic varieties. Among the indigenous Himalayan tree are Schima and Laurels. Wild apple, Raspberry, Oak, Rhododendron, Bamboo are other plants. Actually there is a mixture of Tropical elements (bamboos) and temperate (oaks) is the theme of forest found in Midland Nepal.

Another very suitable example of Nagarjun forest in the Midland of Nepal has been given by Kanai and Shakya (1973). This forest makes the northwest boundary of the Kathmandu Valley, which consists of 4 types of forests:

1. *Schima wallichii* forest
2. Dry oak forest
3. Mixed broadleaved forest
4. Chirpine forest

According to them, *Schima wallichii* are found on the major part of the hill while mixed broad-leaved forest occurs in north facing slopes. Dry oak forest occupies in a southern or western slopes near the ridge in higher places. Pine forests are found in drier southern slopes of the hill. In the *Schima wallichii* forest, the shrub layer

consists of *Machilus dutheii*, *Phoebe lanceolata*, *Quercus spicata*. Humid places are occupied by *Juglans regia*. In shrub layers *Myrsine semiserrata* is often found.

2.2.5 Distribution of Forests

Stainton (1972) gives some important comments about the distribution of forests in Nepal. According to him, the central Midland forest has almost little or no resemblance with the wet Midland forests which has similarity with those of Kumaon (India). On the other hand, the east midland forest has resemblance with those of Sikkim (India). However, the Sikkimese elements fall rapidly between the Arun and Dudhkosi rivers. The meeting of these forests types is in Pokhara which is exceptionally wet. Ignoring this point, it can be mentioned that in majority parts of central Midlands, the western Forest types are generally present on the south faces and eastern forest types are found on the north faces.

Table 2.2: Total Revenue from Forest Products, FY 2057\2058 to 2060\2061

FY	Forest Products		Revenue (Rs.)	NWFPs	Revenues (Rs.)	Total Revenue
	Timber (CFT)	Fuelwood (Chatta)				
2057/058	2700998.01	4890.18	416023117.40	MAPs, Taxus, Resin, Kahir, Lokta etc.	16082820.57	432105937.97
2058/059	1901617.42	2913.66	358570438.90		63307265.29	42187704.19
2059/060	2215139.89	3329.81	437386477.51		67377248.00	504763725.51
2060/061	1871423.91	2593.20	450586946.33		42235104.90	492822051.23

1 Chatta = (20*5 1984

NWFPs: Non Wood Forest Products

MAPs: Medicinal and Aromatic Plants

Source: National Forest Division, Dept. of Forest.

Table 2.3 Protected Areas of Nepal's National Parks, Wildlife Reserves, Hunting Reserves, Conservation Areas and Buffer Zones

Description	Gazetted years	Area (sq.km).
<u>National Parks</u>		
1) Royal Chitwan National Park	1973	932
2) Sagarmatha National Park	1976	1148
3) Langtang National Park	1976	1710
4) Rara National Park	1976	106
5) Shey-Phoksundo National Park	1984	3555
6) Khaptad National Park	1984	225
7) Royal Bardia National Park	1984	968
8) Makalu Barun National Park	1991	1500
9) Shivapuri National Park	2002	144
Total		10288
<u>b) Wildlife Reserves</u>		
1) Royal Shukla Phanta Wildlife Reserves	1976	305
2) Koshi Tappu Wildlife Reserves	1976	175
3) Parsa Wildlife Reserves	1984	499
Total		979
<u>c) Conservation Area</u>		
1) Annapurna Conservation Area	1992	7629
2) Kanchanjangha Conservation Area	1997	2035
3) Manaslu Conservation Area	1998	1663
Total		11327
<u>d) Hunting Reserve</u>		
1) Dhorpatan Hunting Reserve	1987	1325
Total		1325
<u>e) Buffer Zones (Areas)</u>		
1) Royal Chitwan National Park	1996	750
2) Royal Bardia National Park	1996	328
3) Langtang National Park	1998	420
4) Shey-Phoksundo National Park	1998	1349
5) Makalu Barun National Park	1999	830
6) Sagarmatha National Park	2002	275
Total		395
Grand Total		26,971 (18.33%)

Source: Department of National Parks and Wildlife Conservation

**Table 2.4 Forest user Group National Level Database,
(Till 9 March, 2005)**

Development Region	No of FUG	Total CF area (hec.) handed over	No of Household
Eastern Dev. Reg.	2578	299104	318598
Central Dev. Reg	3250	249040	389094
Western Dev. Reg.	3250	171169	405864
Mid-Western Dev. Reg.	2517	279890	278313
Far-Western Dev. Reg.	1984	139788	182960
Total	13967	1138991	1574829

Source: Community Forestry Division, Dept. of Forest.

2.3 Issue and Context

The Shivapuri National Park, initially established as Shivapuri Watershed Reserve in 1976, Shivapuri Watershed and Wildlife Reserve in 1984, and located 12 kilometers north of the Kathmandu metropolis, was gazetted in 2002. The locals living in and around the park have been complaining that they are being denied access to and use of natural resources. Caught between wildlife (wild boars, porcupines) wreaking havoc with their crops and the army protecting the park, they say they increasingly feel like prisoners. Their mobility has been severely restricted: after sunset, if inside the park, they cannot exit; and if outside, they cannot enter. They have to wait another day. Moreover, the locals, who have depended on the nearby forests for fuel wood and non-timber forest products for generations, can now be detained or/and fined, if caught doing so. Quite clearly, conservation has come to Shivapuri at the expense of the local communities, and with scant regard for the rights of the indigenous peoples living in and around the park

The Shivapuri watershed is one of the main sources of water for the Kathmandu valley residents. Complaints have been lodged against the Shivapuri communities for polluting the source. To protect this water source, one of the options being considered in the new management plan developed by the King Mahendra Trust for Nature Conservation (KMTNC) is relocating the communities living inside the National Park. There is every chance that the government may hand over the management of the national park to private sector. If this happens, this will be deemed a controversial move, given that there is already a call for participatory and co-management approach involving local communities as key stakeholders in park management.

Coincidentally, all this development has come about at a time when conservationists as well as mainstream conservation organizations have come under scathing criticism for their disturbing neglect of the indigenous peoples whose land they are in business to protect.

Sarita Timalisina: "If they (the government) give us basic amenities like drinking water we're better off under their protection. However, it is up to the government to

make a decision regarding village toilets - whether to manage them themselves or to get rid of them."

Chitra Bahadur Gurung: "We will die if we have to relocate. But if the government is willing to provide us with proper housing with safety shutters, we will have to agree to their plan if it ever comes up."

Maya Thapa: "They shouldn't do this to us. Where is the government going to relocate so many of us?"

Dawa Sherpa: "They might relocate us. If they give us no choice as to where we want to relocate, there is nothing we can do. What can we do? We might have to go along. Let them kill us, chop us down. If we decide to stay put against their will, they will throw us out. Let them."

Bhiva Gurung: "I don't want to leave my village. I want to stay right here."

Pulman Gurung: "If we must relocate, we will. But they have to provide us with the kind of amenities we already enjoy here."

Sita Lama: "It's not right to just say: 'I will go.' If all agree to relocate, I will also relocate, if they don't, I will not either."

Sang Tshring Lama: "I don't know whether it is right or wrong to relocate the village(s)."

Kanchhi Maya Gurung: "They [people working for the park] ask for Rs 10 per household in this village and the next; however, they don't spend even Rs 5 for the welfare of these villages. If we don't give, they threaten to imprison us; they say they will send the army after us. We need permission to take our farm-produce to the market. There is restriction on collecting mushroom, and *niuro* (fern-like edible plant). We used to sell wicker baskets and *dokos*, and now there is ban on their sale too."

Experts' Opinion

Surya Bahadur Pandey, Deputy Management Officer, Department of National Parks and Wildlife Conservation: "We provide wood, sand and stone for free to the locals and are prepared to mobilize economic assistance by partnering with development organizations. The locals can visit our department. They can go to Sundarijal range post, army barracks and the national park headquarters. If they submit an application at the headquarters in Panimuhan, we can provide soil and stone for toilet construction

for free. In all national parks, it is common practice to give away materials such as wood, soil and stone as per the submitted estimates."

He further explained: "It is not proper to complain that wild boars or monkeys have destroyed crops, now that this is national park. Management plan is under consideration. Rules and regulations will be formulated, and through people participation appropriate measures will be implemented. The stonewall is there to prevent the locals' livestock from straying into forests, as well as to keep wildlife from straying into people's fields. The wall needs to be repaired. We need to build motor able road as well. All this we will do."

T. C. Lama, on Vishnu Budhanilkantha Village Development Committee: "There is restriction on collecting fodder and wood. How can the villagers cook meal without fuel wood? National park is fine. But they must also assume greater responsibility. It is not enough to make law. The national park has a boundary wall, but it is of no use. Since the establishment of national park, the wildlife population has increased. The wildlife doesn't run away from us. We grow corn, but wild boars destroy it. The farmer cannot protect his corn. We cannot kill wildlife, so the management must repair stonewall to prevent wildlife from venturing into our fields."

Karna Shakya, Tourism Entrepreneur: "When I went to Kenya, I saw a billboard at the airport that read: The Capital Closest to the National Park. It promoted Kenya's national park. Now we have gone Kenya one better. The Shivapuri National Park is only seven kilometers from the international airport. We must likewise publicize this park."

Dr. Siddhartha Bajracharya, Team Leader, Management Plan Unit, and King Mahendra Trust for Nature Conservation: "We are focusing on community-based conservation. There are essentially four aspects to the management plan we're developing: 1) biodiversity conservation; 2) village tourism development; 3) whether it is possible to take conservation and community development hand in hand; and 4) institutionalization of delegation of responsibility to local communities through capacity building or their relocation and seeing how they can benefit from conservation - whether through exposure tours or provision of related education to enhance their organizing capability.

"Shivapuri is and has always been the main source of water for the Kathmandu valley residents. The best option is to relocate the village(s) elsewhere. Another possibility is to develop village tourism so that the communities are able to make income, raise their education and health standards, and thus live better than now. They would then be less likely to pollute the water reservoir. Another option is if they wish, we can provide them skill-development trainings, and if they relocate, this would be an ideal outcome from the point of view of protecting the water source.

2.4 Status of Wildlife Conservation in Nepal

Wildlife and nature object is as old as mankind. In the past man was reared together with the wildlife in the state of nature. Man is now slowly learning to revert back to his inherent old idea to be and become admist once more with nature. Of all the objects of creation man owes nature much; he has an ethical imperative and emotional drive to protect the species of plants and animals that share the hostile planet- “the good earth”. Wildlife gives immense satisfaction and acts as natural or outdoor tranquilizer, which can never compare with any man-made medical tranquilizer. The wild and scenic Nepalese natuescape will be a panacea and provide tranquility to the civilized world. Nepalese wildlife status share much is common with the wildlife of the Asian sub-continent so that to review the status is an important as well as a difficult task.

2.5 Hindus Speculation of Wildlife in Pre-history

The Vedas (2000-5000 BC) mentioned of lion, wild pig, and tiger. Balmiki-Ramayan describes, “I have seen animal passing fair in jungles.” Krishna Charitra describes how the foot of Lord Krishna gave illusion of the ear waving of a deer and evoked a hunter to shoot. Similarly, the Hindu holy Puranas describe the passion and love of king Nriga with “deer” pet and how he himself became a deer in his next birth. Vedavyasa, the Maharshi of antiquity, describes how a deer in mating mood cursed king Pandu.

Many a vivid illustration can be drawn from Siva Puran about the love of Lord Siva in “Ban Bihar” and how this hobby used to restore the mood of the Lord. Siva in hunting mood is described in many epics. Hindu religious instinct has protected diverse groups of animals. The tiger is regarded as the carries of Goddess Durga, elephant as the carrier of Indra, Garuda as the carrier of Lord Vishnu, mouse as carrier of Ganesh, buffalo as the carrier of Yama, dog a carrier of Dharmaraj, swan as carrier of Goddess Saraswati, Owl as the carrier of Lakshmi, Peacock as a carrier of Kartika, etc. it has been mentioned that the eight celestial points were guarded by elephants. Hindu theory of evolution shows cosmic drama of incarnation of Lord Vishnu this earth in the form of transitional “Man-Animal”.

2.6 Conservation

Conservation means not only the preservation and protection of natural resources, but also there wise user. This concept applies to the exploitation of landscapes, animals, plants, soil and water. The form of wildlife conservation has been used to include an ever-widening group of animals-fish, birds, mammals, reptiles, amphibians, anthropoids, mollusks and many economic varieties of plants. Wildlife includes a

broad spectrum of plants and animals that are aesthetically, scientifically and economically important.

Nepal is an agricultural country and our economy depends upon soil, where our water resources, crops, forests and wildlife gain footholds.

(a) Land

Land is the basic resource, which may put to multiple uses. The land serves as a storehouse of minerals, a reservoir of water, a conserver of soil fertility, a producer of vegetative crops, a model house for livestock and wildlife. Furthermore, land serves as record book of historical sites and archaeological remains. A wise land use may thus be beneficial to the national economy.

(b) Water

There is perennial storage of water in porous soil, snow clad mountains and rivers and springs. Grazing in mountain parks and lumbering reduce water retention capacity of the soil, which decreases small furred animals and game birds. The water in streams and lakes supports fish and other aquatic animals and may also be used for irrigation, Hydropower production, etc. in mountain region; water in dry season is so scarce that it may equate to the value of liquid gold. The swampland habit and marsh provide a modest shelter for wetland birds such as wild fowls and fish.

2.7 Declaration of Protected Areas and Sustainable Management

Nepal has a relatively short history of establishment of national parks and wildlife reserves. Nepal faced various political situations under the monarchy system. Under the Rana monarchy from 1846 to 1950 Nepal was not opened to any foreigners except the British. However, some areas in the country had been set-aside as hunting reserves by the Rana Regime (1846 – 1950) the concept of conservation first came into existence during the 1950s and the first wildlife law was promulgated in Nepal in 1957. Since then almost all five-year development plans have stressed the need for conserving wildlife. The Aquatic Animals Protection Act (1959) was passed in 1961, in which the importance of wetlands and aquatic animals was emphasized. The act prohibits the use of poison and explosive materials in water bodies and the destruction of dam, bridge or water system with the intent to catch or kill aquatic organisms. A small rhino sanctuary was established in Chitwan in 1964 to protect the population of one-horned rhinos (*Rhinoceros unicornis*) with the help of a group consisting of soldiers and trained people, and known as Gaida Gasti (Rhino patrol). Subsequently, in 1969, six Royal hunting reserves in the terai and one in the mountain area were gazetted under the Wildlife Protection Act 2015 (1969), but effective management

could not be achieved because of the absence of adequate regulations, organization and staff (HMG, 1988a).

In 1970, His late Majesty the King Mahendra approved in principle the establishment of the Royal Chitwan National Park and Langtang National Park. In 1973, a National Park and Wildlife Conservation (NPWC) Act came into force and a long-term project was begun with the help of the FAO & UNDP. The 1973 Act provided broad legislation for the establishment of National Parks and Reserves to protect areas and species. Since 1973, the act has undergone through its fourth amendment (HMG, 1995).

Four types of protected areas has been described under section 2 of the NPWC Act of 1973, namely National Park, Wildlife Reserve, Hunting Reserve and Conservation Area.. In Nepal at present 16 protected areas exist viz., 8 national parks, 4 wildlife reserves, 3 conservation areas and 1 hunting reserve covering about 16 percent of total land area of the country.

As of 1997, there were 13,321 different parks or equivalent reserves internationally recognized by the World Conservation Monitoring Centre (WCMC), which covered a land area of about 6,145,310 square kilometers (IUCN, 1997). National park is a protected area managed mainly for ecosystem protection and recreation.

Table 2.5 Status of Protected Areas of Nepal

	Protected Areas	Year of Declaration	Area sq.km	Physiographic zone
1	Annapurna Conservation Area	1992	7,629	Middle mountain
2	Dhorpatan Hunting Reserve	1987	1,325	Middle mountain
3	Kanchanjunga Conservation area	1997	2,033	Middle mountain
4	Khaptad National Park	1984	225	Middle hill
5	Koshi Tappu Wildlife Reserve (Ramsar site 1987)	1976	175	Terai
6	Lantang Nation Park	1976	1,710	High mountain
	Lantang Buffer Zone	1997	420	High mountain
7	Makalu Barun Nation Park	1991	1,500	High mountain
	Makalu Barun Buffer Zone	1998	830	High mountain
8	Manaslu Conservation Area	1998	1,663	High mountain
9	Parsa Wildlife Reserve	1984	499	Terai Siwaliks
10	Rara National Park	1976	106	High mountain
11	Royal Chitwan National Park (WHS* 1979)	1973	932	Terai Siwaliks
	Royal Chitwan Buffer Zone	1996	750	Terai
12	Royal Bardia Nation Park	1976/88	968	Terai Siwaliks
	Royal Bardia Buffer Zone	1997	328	Terai
13	Royal Suklaphata Wildlife Reserve	1976	305	Terai
14	Sagarmatha National Park (WHS* 1979)	1976	1,148	High mountain
	Sagarmatha Buffer Zone	2002	225	High mountain
15	Shey Phoksundo National Park	1984	3,555	High mountain
	Shey Phoksundo Buffer Zone	1999	449	High mountain
16	Shivapuri National Park	1984/2002	144	Middle hill
	Total Area (sq. k.m)		26,696	
	Land Covered by Protected areas (%)		18.14%	

*WHS: World Heritage Site Source: DNPWC 2002a

Figure 2.1 Ecological Zones and Protected Areas of Nepal

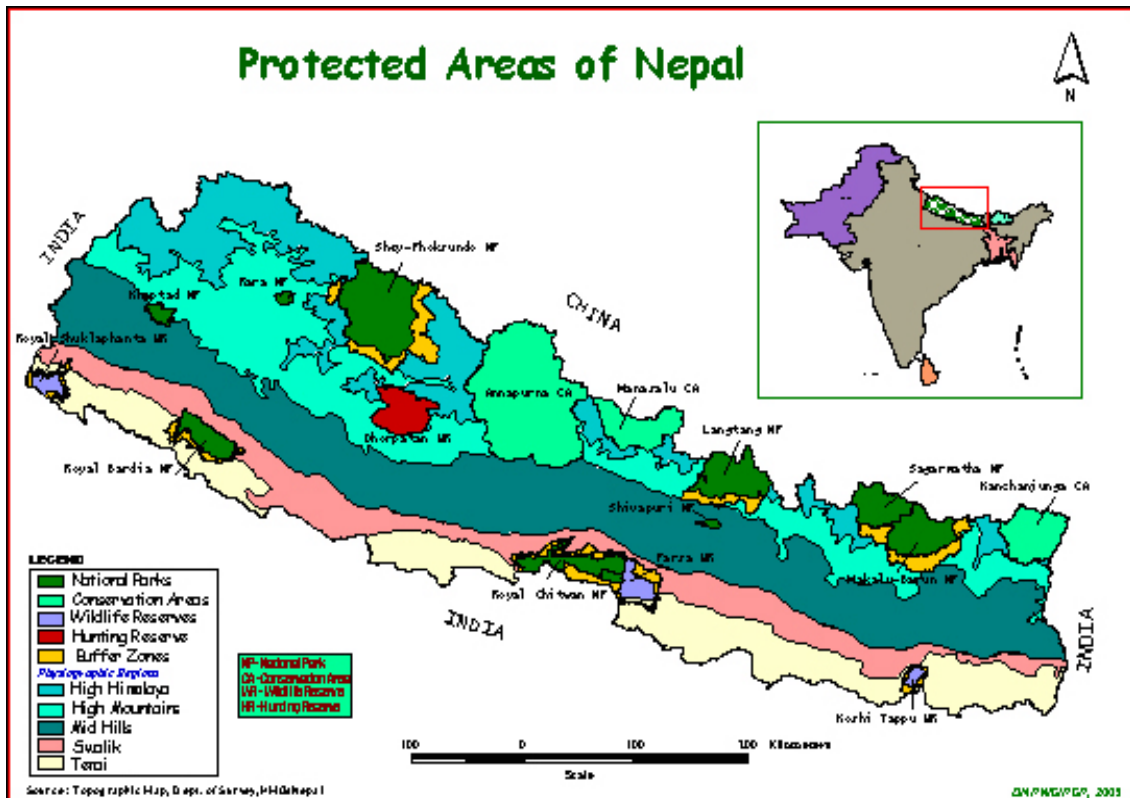

Source: Department of National Parks and Wildlife Conservation 2000.

Map shows the ecological zones and protected areas of Nepal.

The lowland Zone covers a narrow strip of Tarai land along the southern edge of the country. Midland is hill range, steep sided valleys. Nepal has three Main River systems Koshi, Karnali and Gandaki.

2.8 Sustainable Management Problem: Park and People Conflict

Conflict issues are mainly related to people livelihood and are difficult to overcome. Protected Area management is always difficult. The problem is limited resources and population growth. Most of the protected areas were established on the public land but it also covered some of the private land. Even in the public land people used to use that land for their various purposes such as for grazing, fire wood, fodder and for timber or hunting, fishing. Once it converted to the protected area, people have no more right to use those resources. This led to the park people conflict. There is unanswered question, if any particular area was not covered under the protection what would happen? When I asked these questions to the local people related to park, they accept that we might have lost all wildlife and flora and other fauna.

Park people conflict is not particular in Nepal; it can be seen in most of the developing countries. In developed world, nature of conflict is different; however, still there is conflict (Bhandari 1998).

Active conservation of habitats has increased wildlife population within protected areas, which start causing damage outside the park. The relation between park-people is imbalanced when the park animals damage outside and disturb the adjacent settlement. Damage of agricultural crop, human harassment, injuries and death, and livestock depredation are the common causes of this imbalanced relationship (Kasu, 1996).

It is very difficult to villagers to understand why wildlife may damage their crops, while they must not kill any wild animal in return. They are not convinced of the rationale of protecting forests and wildlife, which they have been utilizing for thousands years.

2.9 Concepts for Sustainable Protection against Natural Hazards

Sustainable protection against natural hazards cannot be based on technical measures alone, but must take social and ecological criteria into account, along with economic factors (see figure 2.2). As key sustainability and in the interest of safety it is essential that measure listed in the following for protection against natural hazards be implemented in the listed order of priority:

- Use of areas at risk from natural hazards should be avoided.
- The effect of classified protection forests should be conserved and improved through maintenance and the establishment of new protection forests.
- Rural areas should be maintained through agriculture and forestry, in particular watershed areas that are prone to erosion.
- All land uses should be risk appropriate.
- An increase in the risks arising from intensive land use and the associated increase in values in threatened settlement areas and along transport routes should be avoided.
- Organizational measures, such as early warning, evacuation, road closures etc., should be implemented.
- Flowing water bodies should be revitalized, and additional retention areas created.
- Existing hazard protection structures should be maintained properly.
- New protection structures should be built.

Figure 2.2 Protection Concepts must Provide Integrated Protection against Natural Hazards

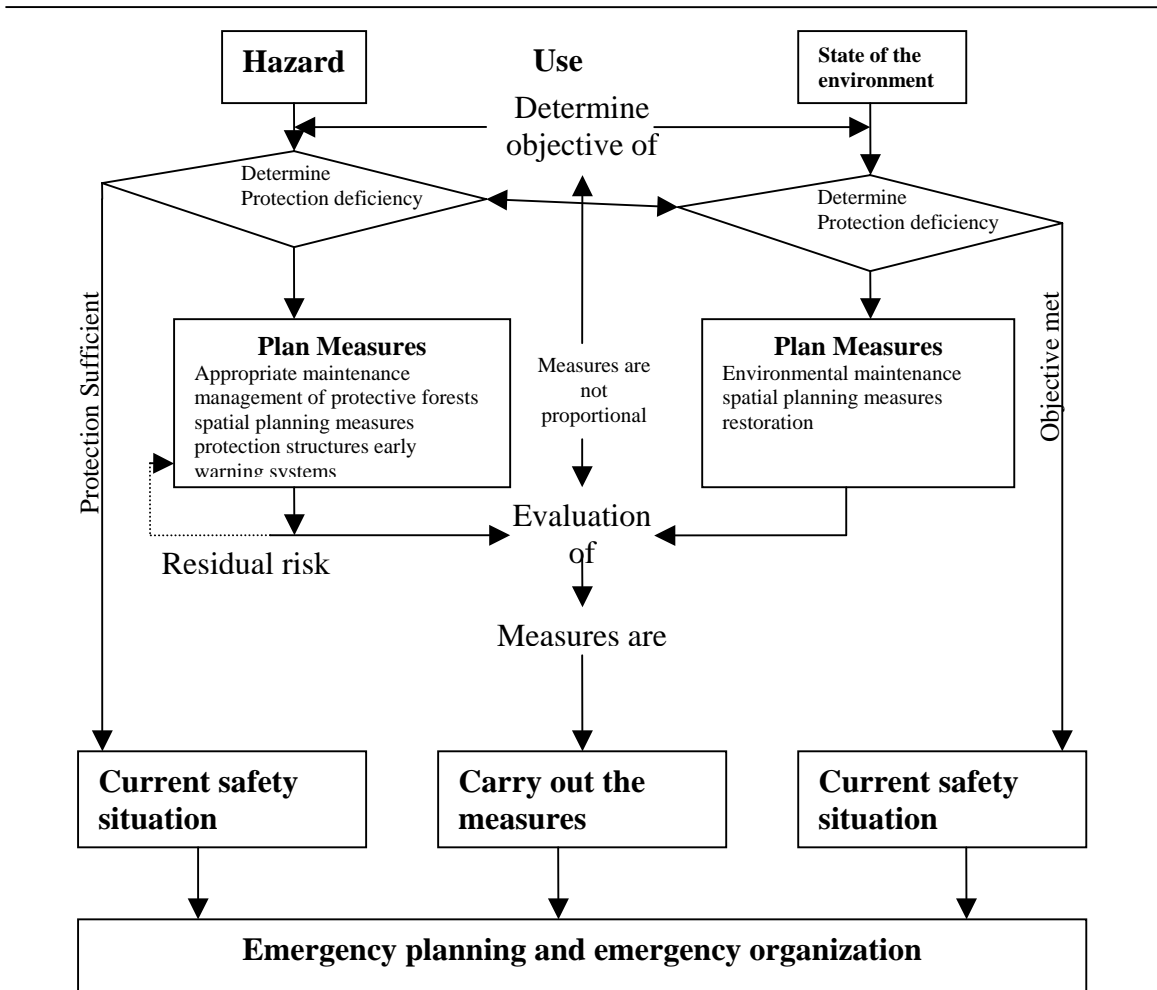

Source: Watershed management case study Nepal

Review and assessment of watershed management strategies and approaches

2.10 The Forestry Sector

Forest resources play a crucial role in the livelihoods of rural populations. The share of forestry in Nepal’s GDP is about 15 percent. As natural forests are not evenly distributed with population density, accessible forests tend to be overused. Linkages between forestry and agriculture are very strong, and can make agriculture more productive and sustainable; 75 percent of the country’s energy requirements are met by fuelwood, and 42 percent of the total digestible nitrogen (TDN) required by Nepal’s forests, which are under heavy pressure, particularly in the hills, supply livestock. Owing to excessive pressure on forests to meet households’ energy, construction and fodder needs to generate household income from forest product commercialization, a number of forests are decreasing in both quantity and quality.

a) Forest cover

Natural forest and shrub formations cover 5.5 million ha, representing 37.4 percent of the country's land area. An additional 15.7 percent of the national territory is shrub lands, grasslands and uncultivated areas that are considered to have good potential for development into forest or pasture. More than a quarter of the forest area is degraded to highly degrade, while 15 percent is in good condition. Almost two-thirds of the natural forest stands are predominantly small-sized timber. Natural forests suffer a lack of regeneration.

Table 2.6 Distribution of Nepal's Natural Forests (ha)

Distribution by crown cover	Conifer	Hardwood	Mixed	Total	Percent
10-40%	230 000	876 000	311 000	1 417 000	26%
40-70%	511 000	1 903 000	772 000	3 186 000	59%
70-100%	186 000	428 000	207 000	821 000	15%
Total	927 000	3 207 000	1 290 000	5 424 000	100%

Source: Adopted from Government of Nepal, ADB and FINNIDA, 1988.

However, in spite of their significantly reduced area, forest lands are still among the most important and valuable natural resources in Nepal.

Forest provides 81% of the total fuel and about 50% of the fodder requirements in Nepal. Wood is the main sources of energy for 99% of the population living in mountains and 80% in the hills. In the hills most farm households are engaged in fodder collection. The practice of buying fodder doesn't exist either in the Terai or in the hills (FAO, 1996).

b) Concept and Definition of Conflicts

The first kind of struggle is common to all people over coming the limits of native and existing technology for example in hunting and gathering society the availability of animals and fruits in the surrounding areas "natural" limit on that society's population and standard of living. Conflicts between two groups got to do with power and authority in our society. All interpersonal conflicts, whether they occur in a family, or between groups have certain elements in common.

One of the popular definitions opined by Coser (1967) asserts that conflict is "a struggle over values and claims to scarce status, power and resources which the aims of opponents are to neutralize, injure or eliminated the rivals."

Burton's (1969) approaches to dealing with conflicts follow from his alternative view of human nature. If basic human needs can be fulfilled in varieties of ways, then give the high costs of destructive conflicts. It would be in the best joint interests of actor persons, groups, organizations, and societies to pursue cooperative resolution of their conflicts.

c) Government Attempts to Solve the Park-People conflict

Numerous successes have been achieved since the coming of the protected area system in the management and protection of biological resources and their diversity, particularly with regard to ecosystems and flagship species. But, while the protected area system came, as a blessing for wildlife there was a price to pay. Strictly restriction and regulations imposed on the people living around these protected areas in the use of forest resources, while, till the coming of the Act, they had ready access to, naturally gave rise to discord between the park management and the local communities. It soon becomes apparent that unless these issues were properly addressed, the government's conservation efforts would not be able to move ahead in a balanced and sustainable manner (www.dnpwc.gov.np).

In recognition this fact, and to rectify the situation, the NPWC Act was amended in 1992 to incorporate provisions for "buffer zones" in the protected area and the sharing of 30-50% of the park\reserve annual with the buffer zones. At round this time, a participatory approach to conservation had already been adopted for the first time by HMGN\DNPWC with the introduction of the conservation area concept in the late 1980s after the Annapurna Conservation Area was established (DNPWC, 2003).

In the Teria parks and reserves as well as, DNPWC gradually started to introduce the participatory approach a forerunner to its buffer zone programme. In nurturing this participatory approach, DNPWC started holding regularly coordination meetings with the local communities and began to exercise a little more flexibility in giving local people access to park \reserve resource use.

Then the buffer zone concept with the amendment of the NPWC Act in 1992. The groundwork for this was laid by DNPWC with the technical and financial support of UNDP through the park people programme (1995-2001). Its achievements are being institutionalized by the participatory conservation programme since 2001. The main objective of establishing buffer zones is to meet the natural resources needs of local communities as well as minimizing human impact on protected areas so as to avoid a contentious situation between the park management and the people. So far, six buffer zones have been declared. These include those at Royal Chitwan National Park, Royal Bardia National Park, Langtang National Park, Shey Phoksundo National Park, Makalu Barun National Park and Sagarmatha National Park (www.dnpwc.gov.np)

With the coming of the buffer zones and proposed buffer zones, the DNPWC, has implemented several programs in different buffer zones with the support of various partner like UNDP, WWF-Nepal Program, IUCN, CARE-Nepal, TAI, DFID, NEDA, and KMTNC. The DNPWC carries out of all buffer zone management activities in close consultation and partnership with the various community-based institutions like user groups, user community, BZMCs and the BZMCs that have been formed (DNPWC, 2003).

2.11 Review of the Related Studies

People's tradition rights to graze cattle, collect fodder, firewood and timber inside the forest have been made illegal since the forested area changed into national park. This has forced the local people to depend on the remaining forest resources outside the national park. Such a situation has to lead to accelerate degradation of the forest patches and growing meadows. At present these areas are seriously encroached by various unpalatable species. Due to lack of alternative resources, local people are forced to graze their livestock in these degraded areas throughout the year. This has become one of the main sources of conflict between the park authority and the local people (Sharma, 1991) cited in (Gyawali, 1994).

The conflict between National Park and local people is rooted in the conception of parks as areas without human habitation. The concept of National Park in the strict sense of "preservation" has thus entangled people in conflict who have traditional use of such areas. Concepts based on intellectual and aesthetic values have little meaning to local villagers who have to struggle day to day out for their existence. If source of next meal is major worry aesthetic or environmental logic for conservation has little relevance to people (Mishra, 1982).

Sharma (1991) found that the main cause of conflict is due to crop and livestock depredation in RCNP. In 1991, he calculated crop damage by two methods i.e interview and Net Area Damage (NAD). He reported that real crop damage was five times less by NAD method than interview. He also reported that paddy is severely damaged followed by wheat, corn, oil seeds, lentils, vegetables and miscellaneous.

Sharma (1980) in his thesis "An Overview of Park-people Interaction in RCNP" takes up the main problems of people arising from park conservation and their resolution. In order to change the villagers habit of forest use Sharma says that they can be encouraged to plant private trees, use of agriculture waste, use of improved stoves, etc. he also suggested that management forest close to villagers that two third area be planted should be managed by park authority as a buffer zone for multiple purpose use including firewood from the park forests should be stopped.

Adhakari (1998) observed the local people's perceptions related to scarcity of firewood and lack of grazing land, fodder scarcity, food deficit, crop damage by wild animals, lack of agricultural land and irrigation, lack of timber, lack of settlement area are the main problems reported by the people. Deaths of animals, fodders and crops disease are other problems.

People's negative perceptions about protected areas are the result of various factors like economic, social and others. Economic factors include prohibition in extraction of wood, fodder and thatch, crop damage, livestock depredation: lack of grazing facilities for animals, and inability to kill animals when they entered the croplands. They have strong feelings that the benefit of the park goes directly to government and foreigners. These are the problems faced in most of the national parks in Nepal. In case of the Lumbini, government did not pay a good price for land when they resettled people. The government promised work to them when they were resettled but later on, it was turned to empty promise. Within the village of RBNP, the villages, indigenous and marginal people and women were found to have been already affected by the park and protected areas. It has been their dominant perceptions for example, in Bardia (BMNP). Tharus are more sensitive to the lack of access to resources in the case of Kakri Bihar, women are more likely to react negatively to protection because they make main responsibility for gathering resources such as fuelwood and fodder. In Lumbini, people with some formal education and people with more than one hectares land are more positive towards the park (Allendorf, 1999).

There are few studies dealing with park-people conflict in SNP.

Ulak (1992) reported that the economic loss of crops (potato, sweet potato, maize, millet etc) in Shivapuri National Park caused by the wild boar (*Sus scrofa*) felt by the local people residing in the park areas since 1987 and attack in the crops is going ahead in an increasing order.

Paudal (1995) reported that on an average, each affected household lost around Rs. 3,132 annually due to crop loss by wild animals in SNP.

Soti (1995) found wild boar as the main crop raider in Shivapuri National Park.

RESEARCH METHODOLOGY

This chapter discusses the research methods employed for the fulfillment of the objectives of the study.

3.1 The Shivapuri National Park

The spatial location of Shivapuri National Park is 27°45'30"-27°50'15" north in latitude 85°16'32"-85°45'30" east, with the elevation range of 1,350m-2,732m. The Shivapuri National Park, a major source of drinking water for Kathmandu, is situated about 12km away from the capital city, on the north part of Kathmandu Valley. The Government removed all small patches of settlements and croplands of local people and built up 114 km long and 2m high stonewall demarcating its boundary and 95km, long motor road inside the Park.

Established in 1976 as a Watershed and Wildlife Reserve, Shivapuri was declared National Park in 2002. It covers an area of 144sq.km and is a true representation of the mid-hills in the protected area system and also meets over 40 percent of the drinking water needs of the Kathmandu Valley. It has a high diversity of forest types (Sal, Terai hardwood, mixed hardwood, chir pine and oak), which occupy 39 percent of the land. A total of 129 species of mushroom, 150 species of butterfly (many endemic and rare), 9 species of birds, which are considered endangered or vulnerable, and 19 species of mammal have been recorded in the park.

While there are 13 trekking routes inside the Reserve itself, the most important is the trekking route to Helambu that passes through Shivapuri. Therefore, it is one of the popular Protected Areas. Its great popularity also comes from its proximity to Kathmandu city. Therefore, after Royal Chitwan National Park, it was the most visited area in 2002, with a tourist influx of 26,652. However, the majority of these visitors were national (MoCTCA, 2002).

The Shivapuri hill is in the top i.e. 2732m, which lies directly to the north of Kathmandu, takes about three hours. The path is alternating level walks through forests and steep inclines. The summit of Shivapuri one of the four pilgrimage peaks on the valley rim. The trail begins behind the shrine of Budhanilkantha (9km, bus and taxi). For the return, you can walk along the ridge that descends south to Boudha where transport is available.

The residents of the study area who are inside and close to the park had been highly dependent on the resources of the forest, such as timber, firewood and fodder. Timber and firewood were the main sources of the income of local people before the establishment of the park. The burden of the park regulations on the use of these resources by the local people results many conflicts between them and the park authority.

3.2 Rationale for the Selection of the Study Area

Budhanilkantha area has been purposively selected for this study. The reasons for selecting these are:

- No similar studies have been carried out in the study area yet.
- The result obtained can be generalized to the entire region.
- Accessibility of the researcher.

3.3 Research Design

The research design of this study has been based on the descriptive and analytical in nature. The study has attempted to assess the socio economic impact of the SNP on the local community of the study area.

3.4 Nature and Sources of Data

Both qualitative and quantitative nature of data has been used to fulfill the research objective. Primary as well as secondary sources of data have been used. Primary source of data has been collected from the selected households and the necessary secondary sources of data have been collected from various related books, journals, research reports, magazines, documentary, publications and related websites from the internet.

3.5 Sampling Procedure

The study has been carried out in Budhanilkantha area of Kathmandu district. Among the wards, sample has been selected through purposive sampling. One hundred three households have been selected as a sample size. The respondents have been selected by purposive sampling method and key informant has been selected purposively.

3.6 Techniques and Tools of Data Collection

3.6.1 Techniques

Following techniques were used in the collection of primary data:

3.6.1.1 Household Survey

Household survey was conducted to assess the knowledge about different aspects of the respondents for the semi-structured questionnaire was administered to the respondents. The questions have been asked to the respondents and answers have been filled up by the researcher herself.

3.6.1.2 Observation

An unobtrusive type of observation was used during the course of field work. Observations were especially focused as socioeconomic setting, settlement pattern, use of fuel wood, collection of fodder etc.

3.6.1.3 Key Informant Interview

Key informant interview was conducted with VDC chairman, social workers. These key informants interviews provided some useful qualitative and quantitative data regarding the National Park and the situation of the park and people, cause of conflict among the park staffs which help to the study of the researcher.

3.6.1.4 Focus Group Discussion

For the purpose of focus group discussion, respondents who came near the park area for the grazing of their livestock were selected for the discussion.

3.6.2 Tools

Primary data is collected using the above techniques. And to fulfill the necessary information for the study of the research schedules and questionnaire have been applied.

3.7 Data Processing and Analysis

Collected data were arranged out, tabulated and processed manually using simple statistical procedures. Data analysis has been done on the basis of the major themes extracted out of the main bulk of data. The statistical measures used were frequency, percentage etc.

KATHMANDU DISTRICT

ZONE : BAGMATI

District Code : 27

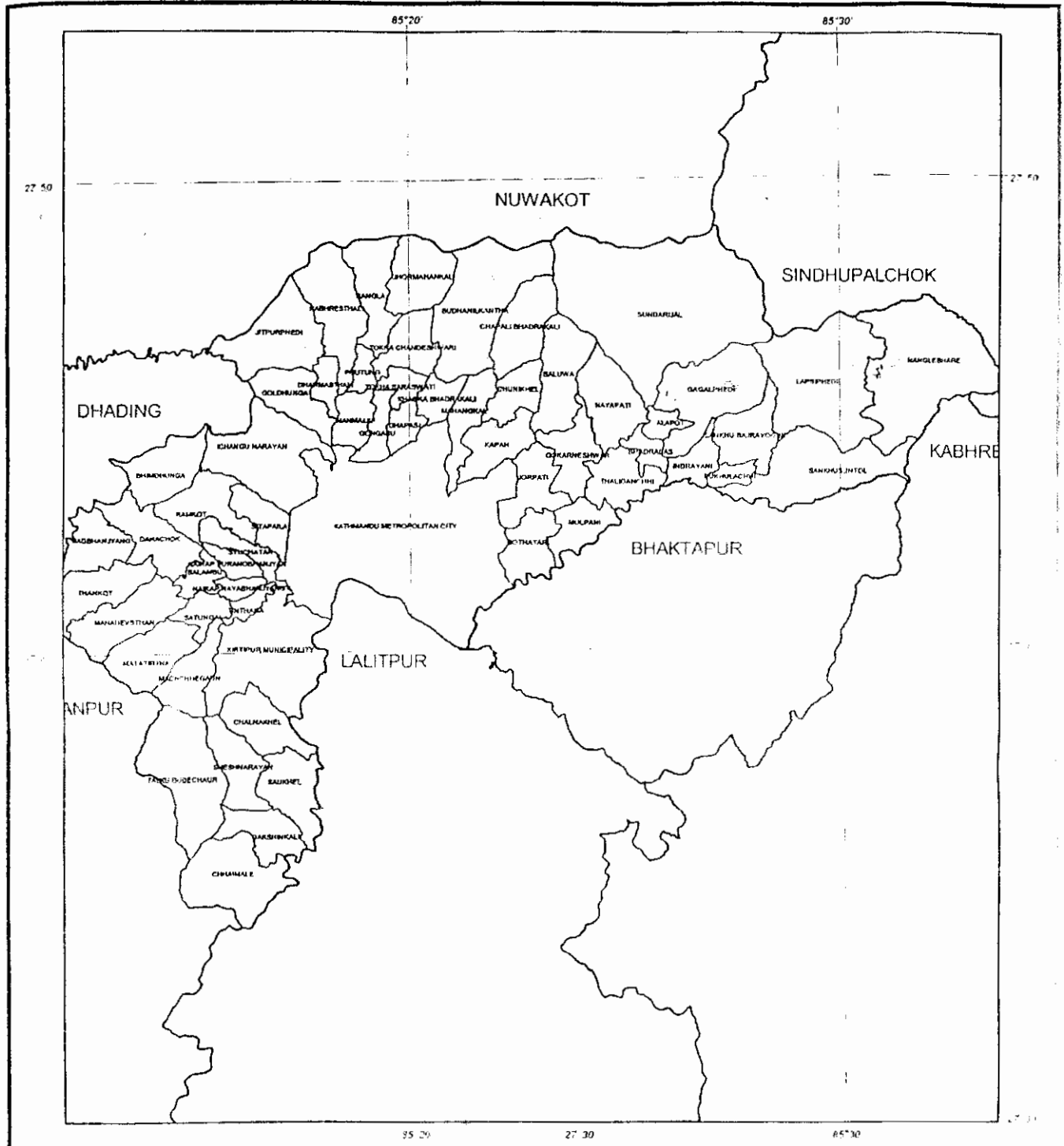

Copyright © Government of Nepal, Survey Department

SCALE 1 : 225000

LEGEND	
	District Boundary
	VDC Boundary
MORANG	District Name
	VDC Name

4500 0 4500 9000 Meters

HORIZONTAL DATUM

Spheroid Everest 1830
 Projection MUTM
 Origin Longitude 84° E., Latitude 0° N.
 False coordinates of origin 500 000 m. Easting, 0 m. Northing
 Scale Factor at Central Meridian 0.9999

LOCATION MAP

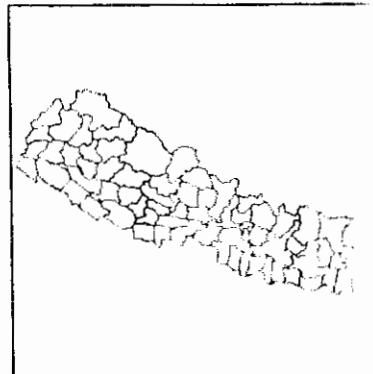

DISTRICT : KATHMANDU
 Area :395 Sq.Km.(Approx.)

Map compiled from National Topographic Database at scales 1:25 000 and 1:50 000. Internal administrative boundaries are not demarcated on the ground. Map produced by the Survey Department, National Geographic Information Infrastructure Programme, (NGIIP), Kathmandu, 2003

BUDHANILKANTHA VDC

DISTRICT : KATHMANDU

VDC Code : 27007

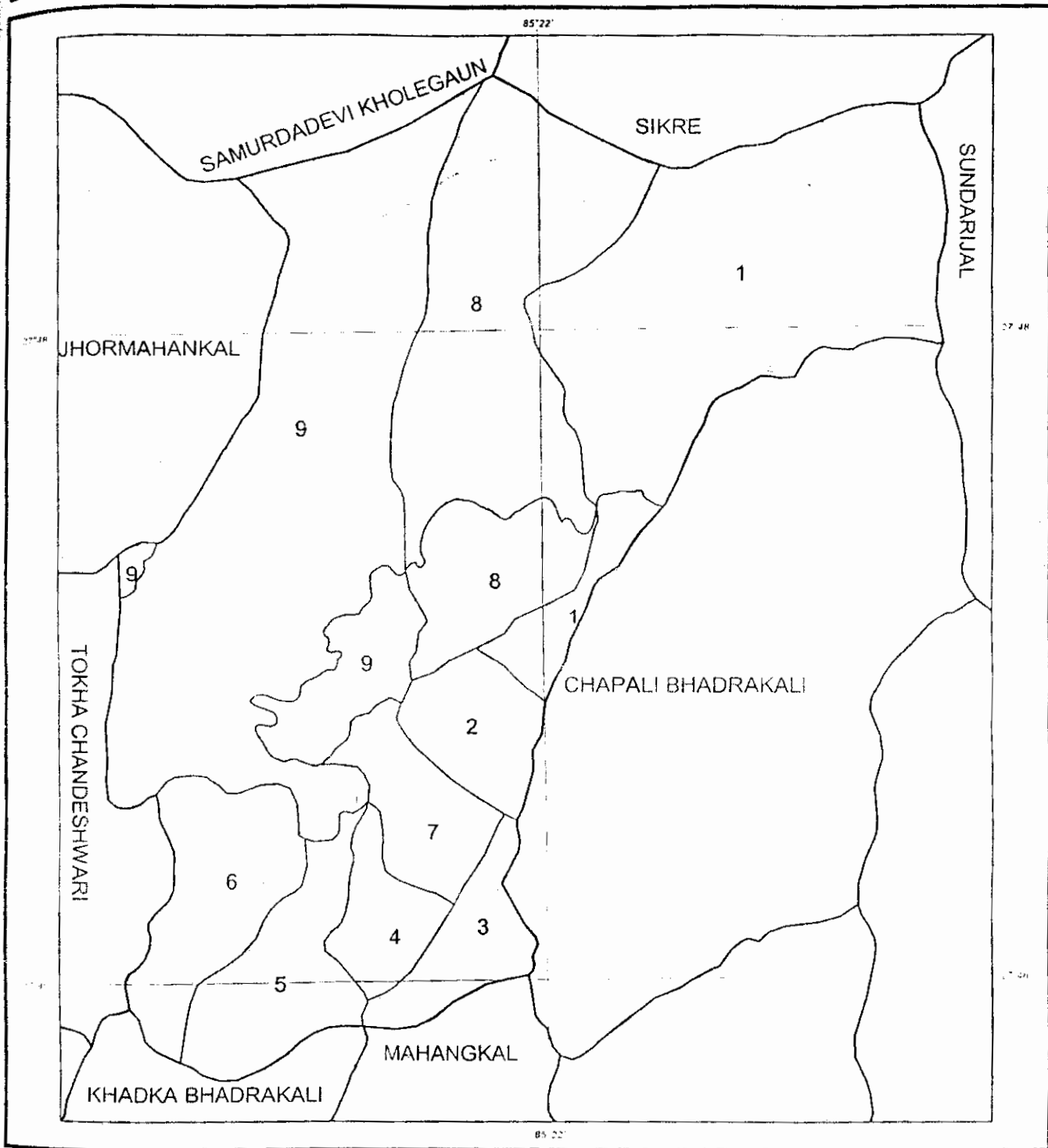

Copyright © Government of Nepal, Survey Department

SCALE 1 : 32500



KATHMANDU DISTRICT
VDC Location Map

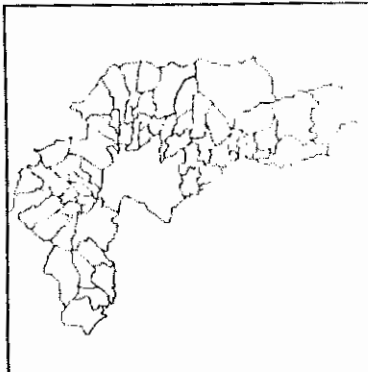

LEGEND

- VDC Boundary
- Ward Boundary
- BUKHEL** VDC Name
- 5** Ward Number

HORIZONTAL DATUM

Spheroid Everest 1830
 Projection MUTM
 Origin Longitude 84° E, Latitude 0° N
 False coordinates of origin 500 000 m. Easting, 0 m. Northing
 Scale Factor at Central Meridian 0.9999

BUDHANILKANTHA VDC
 Area :13 Sq.Km.(Approx.)

Map compiled from National Topographic Database at scales 1:25 000 and 1:50 000. Internal administrative boundaries are not demarcated on the ground. Map produced by the Survey Department, National Geographic Information Infrastructure

THE STUDY AREA

4.1 Short Profile of Budhanilkantha Area

Bishnu Budhanilkantha VDC is located 9 km north from the Kathmandu, the capital city of Nepal at the base of the Shivapuri Hill. Shivapuri Hydropower and Wildlife Reserve are located at the north of this VDC. Chapali Bhadrakali VDC is located at the east of this VDC Khadga Bhadrakali and Chapali Bhadrakali VDC are located at its west and Khadga Bhadrakali is located to its south. The climate of this VDC is mild temperate. This VDC is slightly polluted. The major pollutions are river pollution and air pollution due to effect of Kathmandu City's pollution. Bishnu Budhanilkantha VDC has been named after the temple of Lord Bishnu i.e. the Budhanilkantha Temple, which is also enlisted in the world heritage list.

The main institutes and offices of this area are Rastriya Banijya Bank, Agricultural Development Committee, Budhanilkantha Police Station, Budhanilkantha Area Development Committee, Shivapuri National Park, and Rotary Club of Budhanilkantha.

4.2 Physical Features

The protected area extends from 9km north to south and about 20km from east to west. The area covers 25 village development committees of the districts of Kathmandu, Nuwakot and Sindhupalchok.

A magnificent view of the Himalayan range can be seen from the top of Shivapuri. The highest peak is the Shivapuri Peak (2732m) sloping down to less than 1000m altitude at the northern border and 1400m at the southern border. At the top of Shivapuri is a flat platform from where panoramic view of central and western Himalaya can be seen. However, Jugal Himal and Langtang are partly hidden. The peaks seen are Himalchuli (7893m), Ganesh Himal (7406m), Langtang (7234m), Gang Chempo (6387m), Loenpogang (6637m), Dorje Lakpa (6966m), Phurbi Chyachu (6637 m), Choba Bamare (5959 m), Gauri Shankar (7134m), Cho oyu (8201m).

Recently a boundary wall (111km) has been constructed. Settlements within the reserve are removed except for the two villages, Mulkhara and Ukraini. The Royal

Nepal Army was posted in the area with security posts at 20 places in 32 units of buildings. A road about 95 km is also built around the reserve and foot trails about 82 km have been constructed and improved. 1193 hectares inside the reserve area and 786 hectares outside the reserve area have been afforested.

About 30,000 inhabitants live in the area while about 3000 persons live inside the protected area.

4.3 Vegetation

The vegetation of this reserve is a good example of typical middle hill forest and lies in a transition zone between subtropical and temperate climate. The vegetation is of a variety of natural forest types depending on aspect and altitude. The majority of the area below 1800 m is covered with *Schima castanopsis* forest in which Pine (*Pinus roxburghii*) is found on southern dry ridges with Utis (*Alnus nepalensis*) along streams. A forest of Oak species such as *Quercus lamellose* and *Quercus semecarpifolia* mixed with rhododendron occurs on the northern slopes. Besides, a variety of medicinal herbs are also found on high elevation.

4.4 Fauna and Flora

Among the wildlife, sloth bear (*Ursus arctos*), Leopard (*Panthera pardus*), barking deer (*Muntiacus muntjak*), wild boar (*Sus scrofa*), common langur (*Semnopithecus = Presbytis entellus*), and wide variety of birds, butterflies are found in the reserve. The vegetation consists of varieties of natural forest types including pine, oak, rhododendron etc., depending on altitude and slope aspect.

4.5 Water Resources

Shivapuri Watershed is one of the main sources of drinking water (about 1 million liter per day) to the densely populated Kathmandu. Water tapped from Bagmati, Bishnumati and several small streams is channeled through pipelines from reserves situated at Sundarijal, Pani Muhan, Tokha, Alle, Dhakel Chaur and Paanch Mawe. Water from streams is also used for irrigation purposes in the surrounding villages.

4.6 Culture and Religion

Shivapuri is important religious place for Hindus and Buddhists. The sacred mountain is a permanent abode of sadhus and saints. A well-known saint named Shri Govindanand Bharti Saraswati popularly called Shivapuri Baba used to live here for about 40 years on a hillock of Shivapuri. He expired in 1963 at the age of 137 years. In this reserve, exist some shrines, stupas and monasteries viz., Budhanilkantha, Manichur, Shivapuri, Tarkeshwar Mahadev, Naghi Gompa, Baghdwar and

Vishnudwar. Two major rivers of Kathmandu Valley, Bagmati and Vishnumati originate from here.

On Nepalese New Year which falls in mid-April devout religious persons from Kathmandu Valley and neighboring valleys flock to Bagdwar and Vishnudwar.

4.7 Tourist Attraction

Shivapuri is equally important from tourist point of view. Impressive view of the High Himalaya can be seen from the northern side of Shivapuri.

It is also an excellent trek around the rim of Kathmandu. Shivapuri can be reached from Budhanilkantha (1500m) on foot in 4 hrs. Its altitude is 2730m. the trek along here passes through a forest. At the top there is a flat platform. The main trekking route to Helambu passes through Shivapuri from Sundarijal. Some naturalists also follow a Shivapur-Kakani trek. Some travel agencies suggest 4 days trek on this route.

4.8 Watershed

Shivapuri experienced several problems of soil erosion owing to deforestation, overgrazing, cultivation on steep slopes. The quality and quantity of water supplied from this area were also reduced. To overcome these problems, program was initiated to protect Shivapuri Development Board was established to ensure a multi-disciplinary supervision and guidance of the project activities.

4.9 Watershed Management

In 1985, Shivapuri Watershed Management and Fuelwood Plantation project was launched with the financial support of the Norwegian Govt. through FAO. In 1992 the project was continued for another 5 years. Now the emphasis is given to the utilization of the watershed area in well-planned way by the local people.

4.10 Fuelwood Management

Earlier Shivapuri was the main source of the Fuelwood for the people of Kathmandu Valley. Now several income generating activities have been introduced for the compensation for the loss of income from sale of Fuelwood from forest. Now projects of cultivation of fruit trees (apple, pomegranate, peach, walnut, pear, plum, chestnut, and orange), vegetables (radish, carrot, lettuce, cauliflower and cabbage), mushroom production, bee-keeping, sericulture, etc. are introduced. Private plantations for fuelwood, fodder and timber productions have also been introduced. For minimizing the fuelwood consumption the improved stoves have also become popular.

4.11 Park's Regulations

- An entry fee has to pay at the park's entrance gate.
- All flora and fauna are fully protected and must not be disturbed.
- Do not purchase illegal animal or plant products.
- Carry out non biodegradable items such as plastic & bottles.
- Place trash in rubbish bins.
- No one should walk within the park between sunset and sunrise
- Respect religious and cultural sites.
- Camping in side the park should be made only at the designed areas.
- Visitors should be self sufficient in fuel supply (kerosene). The use of firewood is strictly prohibited.

DATA PRESENTATION AND ANALYSIS

This chapter attempts to accomplish the presentation work of the evidence events relating to respondents' demographic and socio-economic characteristics. Likewise some major issue related to National Park. The respondents' knowledge about sustainable uses, conservation and protection etc. related to Park on the basis of data extracted from field questionnaire. The main areas of this chapter are under four sub-headings;

- Demographic and Socio-Economic Conditions
- Natural Resources Accessibility
- Perception of Respondents about the National Park
- Area of Conflict

Analysis and interpretation are considered as the important steps in any research study. This chapter clearly deals with tabulation, analysis and interpretation of the findings on the basis of the information gathered during the study time.

5.1 Demographic and Socio-economic Conditions

The section below briefly deals with social composition of the respondents, literacy rate and economic structure of the study area.

5.1.1 Gender of the Respondents

Based on the gender, the respondents, under study can be categorized as male and female. The researcher asked the question to both of them as the sample size.

Table 5.1: Distribution of Respondents by Gender

Gender	Frequency	Percentage
Male	57	55.00
Female	46	45.00
Total	103	100.00

Source: Field Survey 2006

Table 5.1 shows that the sample respondents in the study area, 55 percent of the respondents are male and 45 percent of the respondents are female.

Figure 5.1: Sample Size by Gender

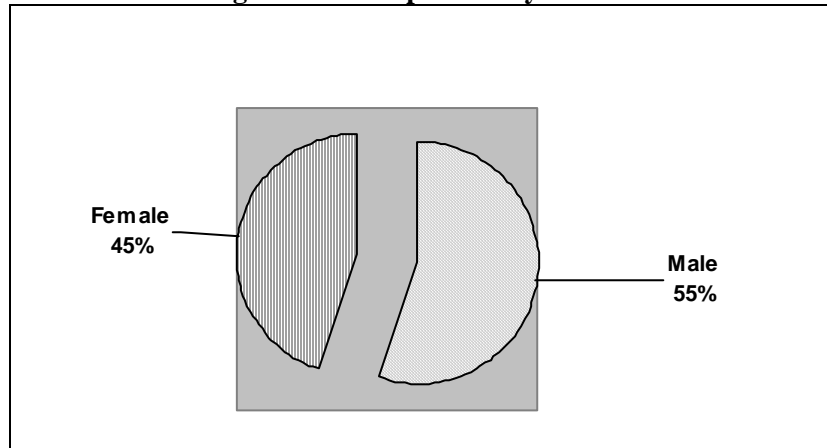

Based on: Table 5.1

5.1.2 Family Structure and Size

Household size also plays a vital role in livelihood pattern. Larger the household size requires more resources, so information regarding the household size of the respondent was also obtained which are shown in the table 5.2

Table 5.2: Distribution of Respondents by Family Size

Household Size	Frequency	Percentage
Less than 5	47	45.00
Less than 10	44	43.00
Above 10	12	12.00
Total	103	100.00

Source: Field Survey 2006

Figure 5.2: Sample by Household Size

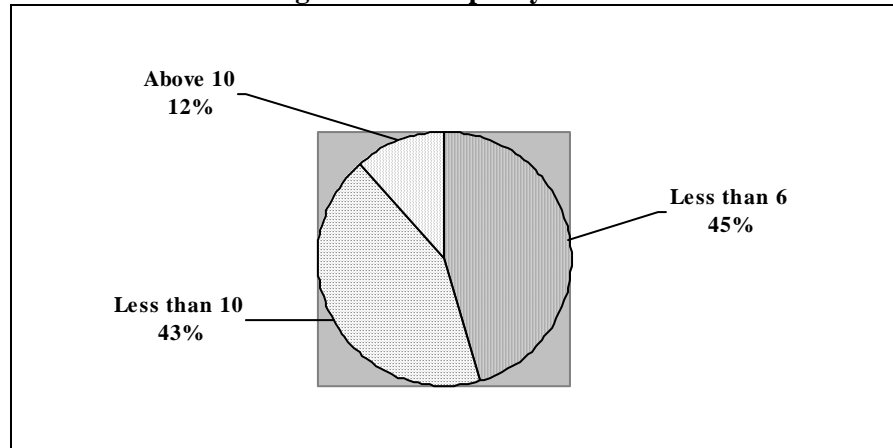

Based on: Table 5.2

Figure 5.2 shows that 45 percent of the respondents having family size less than 5, who are considered as an ideal family. Most of them are literate and having good economic condition. 43 percent of the respondents having family size less than 10 and 12 percent of respondents having family size more than 10.

From the above data, it clearly indicates that the respondents having large family size due to illiteracy and ignorance of the family planning. The government should give awareness programmes to the local people through which people are conscious about the family planning.

5.1.3 Religion of Respondents

Religion, although a simple term in its appearance, is as much complex and vague in its meaning, definition and scope. It is a very powerful motivating force, which bind people together in a bond of mutual harmony and integration. People of a particular religious community share common religious and cultural values, which influence the socio-economic life of the community. In this view, religions of the households have been taken into consideration.

Table 5.3: Ethnic Composition of the Respondent

Religion	Frequency	Percentage
Hindu	95	92.00
Buddhism	8	8.00
Total	103	100.00

Source: Field Survey 2006

Figure 5.3: Sample by Ethnicity

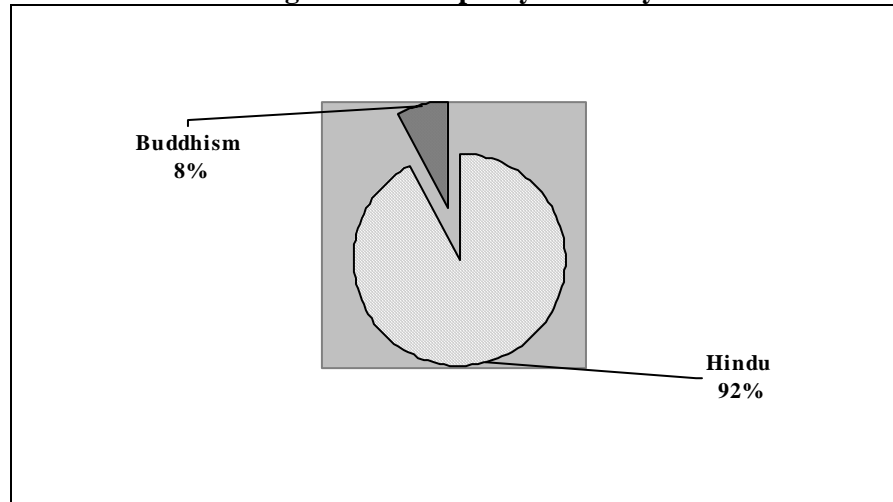

Based on: Table 5.3

Figure 5.3 indicates that there are mainly two different ethnic groups in Buddhanilkantha area. Out of 103 respondents, 92 percent of respondents are Hindu and only 8 percent of respondents are Buddhists.

It showed that mostly Hindus are lived in Buddhanilkantha and very minimum numbers of respondents are Buddhists.

5.1.4 Education

Education is the indicator of quality of development. It plays the crucial role in the development of society and country. To know the socio-economic condition of any society, education is assumed as affecting factor.

In general literate means a person who can simply read and write. The CBS suggests that the ability to read and write one's own name may also been interpreted as being literate. The literacy status of respondents has been present in the figure 5.4

Table 5.4: Educational Attainment of Respondents

Education	Frequency	Percentage
Literacy	64	62.00
Illiteracy	39	38.00
Total	103	100.00

Source: Field Survey 2006

Figure 5.4: Educational Status of the Respondents

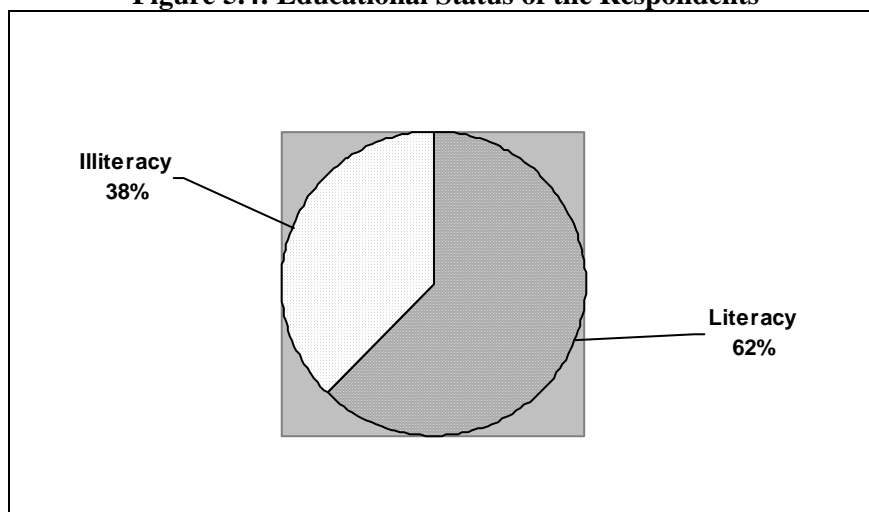

Based on: Table 5.4

Figure 5.4 show that the 62 percent of respondents are literate which is not satisfactory as compared to the distance from the capital city Kathmandu, although the majority of the respondents are literate. 38 percent of respondents are illiterate because of the low-income level they could not read and write.

5.1.5 Occupation of the Respondents

Occupation determines the social status of the people. It helps to raise the life style of the people and it not only gives a social and economic identification but also determines the hierarchies of the people they enjoy in their locality, especially in rural society. Occupation of the household head not only influences the entire family. Occupation is an important characteristic to contribute and participate in bio-diversity conservation activities.

Table 5.5: Distribution of the Respondents by Occupation

Occupation Type	Frequency	Percentage
Agriculture	57	54.00
Labor	15	15.00
Service	14	14.00
Industry	1	1.00
Others	16	16.00
Total	103	100.00

Source: Field Survey 2006

Table 5.5 shows that agriculture is the main occupation of the study area, where agriculture is the main income source of households.

Out of 103 respondents, 54 percent of respondents are engaged in agriculture as their occupation, 15 percent of respondents are wage labor. Wage labor is another complementary occupation of the household from which they earn cash for their livelihood. 14 percent of respondents are engaged in the service sector, they are economically sound. 16 percent of respondents are engaged in different sectors like business and poultry farming. Business is another income source of the respondents and only 1 percent of respondents are engaged in the industry sector.

Figure 5.5: Occupation Pattern of Sampled Households

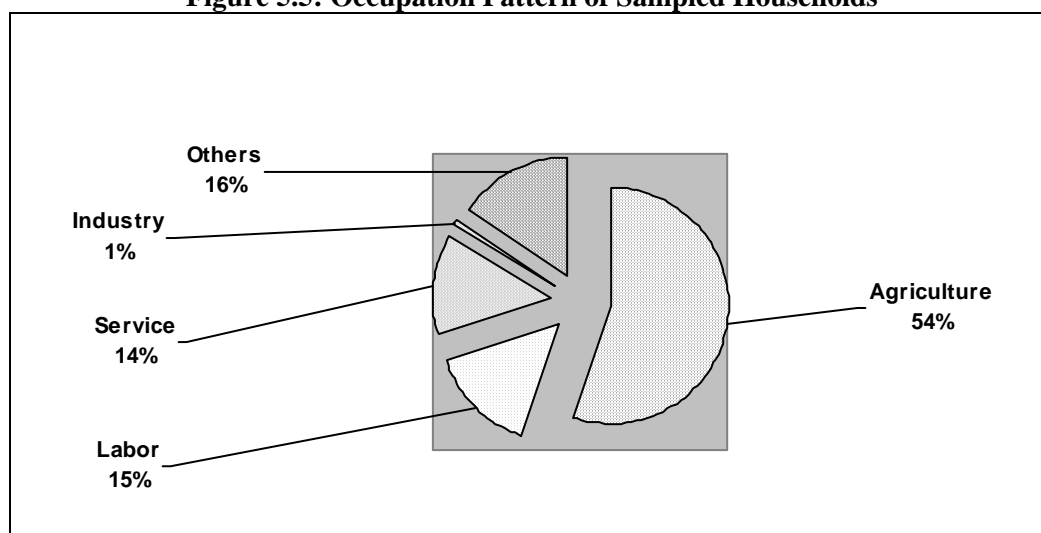

Based on: Table 5.5

5.1.6 Land holding

Family property of an individual gives social status and identity to him\her. In this view, economic status of the household has been taken into consideration. The sampled household economic status was operationally defined as relative wealth status of the household in the community in terms of property such as land, livestock, agricultural production, business and services.

Table 5.6: Distribution of Respondents by the Land holding Size

Land Holding	Frequency	Percentage
Less than 1 ropani	7	7.00
Less than 6 ropani	65	63.00
Less than 10 ropani	10	10.00
Above 10 ropani	1	1.00
No land	20	19.00
Total	103	100.00

Source: Field Survey 2006

Table 5.6 reveals that 7 percent of the respondents have land less than 1 ropani who have got very difficult to sustain their life only from its earnings. 63 percent of the respondents have less than 6 ropani also get difficulty to survive only from its products. The respondent's having land less than 10 ropani are 10 percent, another 1 percent of respondents have land above 10 ropani who are considered as a high economic condition as compared to the other respondents. There are 19 percent of the respondents are landless. These respondents have low economic condition and sustain their life very difficult way normally these are labor workers.

Figure 5.6: Sample by Land holding Size

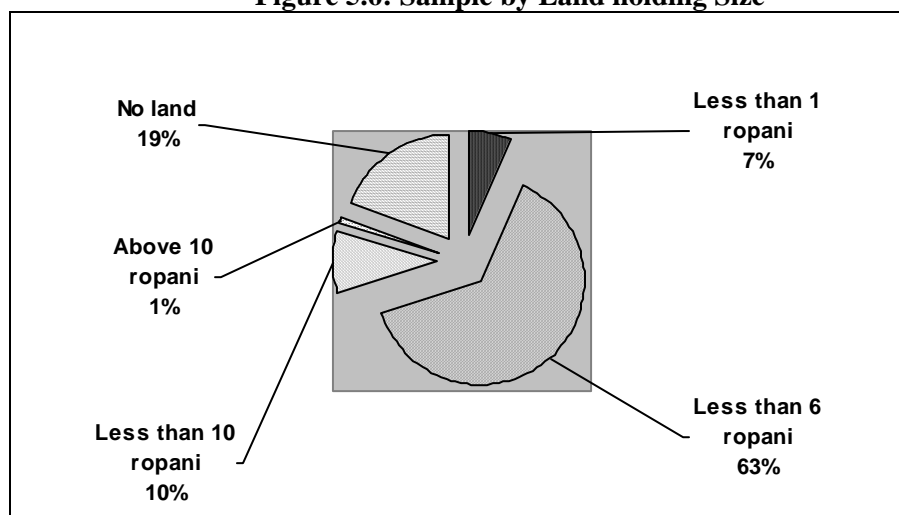

Based on: Table 5.6

5.1.7 Income Source

In Nepal where 45 percent of the total population is below the poverty line, the main aim of the people is to earn the livelihood. So, income not only provides a financial security but also a social and economic status to the family. In this view, income of the sample households has been taken into consideration.

Table 5.7: Distribution of Respondents by their Monthly Income (Rs)

Income(Rs)	Frequency	Percentage
0-1000	12	12.00
1000-3000	26	25.00
3000-5000	33	32.00
5000 and above	27	26.00
No answer	5	5.00
Total	103	100.00

Source: Field Survey 2006

Figure 5.7: Sample of Respondents by their Monthly Income (Rs.)

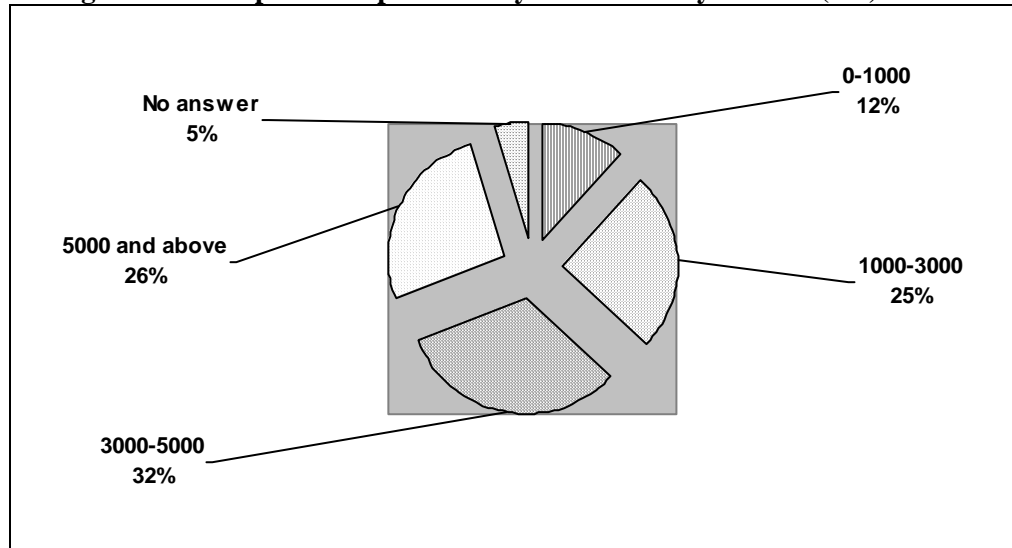

Based on: Table 5.7

Figure 5.7 indicates that the majority of the respondents have monthly income between Rs 3000-5000 which constitutes 32 percent; they have good earnings in comparison to other respondents. It is because of their involvement in service sector. While there are 12 percent of respondents have monthly income less than Rs.1000. whose income level of earnings is low because of landlessness, land erosion, inadequacy of land, physical weaknesses, less workable forces and short period of workings in agriculture, where the cost of labor, is Rs. 60 to70 per day. In other words, the cost of the labor is about one dollar for a day per person.

On the other hand, there are 25 percent of the respondents having the income level between 1000-3000 monthly, whose main source of income is dependent on agricultural sector whether they earn money through laboring on other's farm or producing more crops in own land. Similarly 27 percent of the respondents have income more than Rs.5000. Most of the respondents involved in business sector through which they earn good money. These respondents have the better life to sustain their livelihood. Rest 5 percent of the respondents did not give answer about their monthly income.

5.1.8 Livestock/ Animal Husbandry

Livestock keeping is another source of income of the local people. Livestock rearing was found to be an integrated, inseparable and important aspect of the farming system and household economy. As in other areas of the country this sector was on important component of the farming system and has contributed a lot in the village economy.

Table 5.8: Distribution of Respondents by Livestock Keeping

Livestock keeping	Frequency	Percentage
Cows	35	29.00
Buffaloes	7	6.00
Goats	42	34.00
Pigs	2	2.00
Chickens	13	11.00
No livestock	21	18.00
Total	120	100.00

Source: Field Survey 2006

Figure 5.8: Livestock Keeping Household

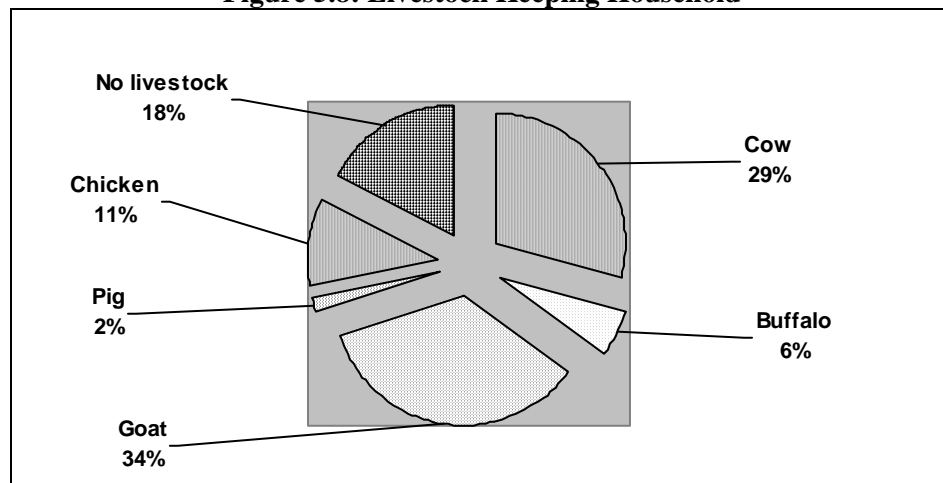

Based on: Table 5.8

Figure 5.8 indicates the respondents of Budhanilkantha area were keeping different kinds of livestock. Most of the respondents were keeping goats because it is easy to keep and feed them. Out of 120 livestock's, 34 percent were goats, 29 percent were cows, 11 percent were chickens, 6 percent of buffaloes, 2 percent were pigs and 18 percent of the respondents were not keeping any type of the livestock's because the study area is near to the city of Kathmandu as well as this respondents have work in service sectors and have their own business. Cows and buffaloes were kept for the purpose of milk and manure. A large number of goats rear for meat and manure. Some houses rear pigs for meat. Chickens rear for meat and eggs. Chickens manure used for farming. Hence, the local people of the study area reared significant number of livestock's although they have no legal access in natural resources of the National Park.

5.2. Natural Resources Accessibility

5.2.1. Collection of Fodder\Grass

The collection of fodder\grass near the National park should be analyzed in national context. The researcher asked the questions to the respondents who have livestock in their home from where they collected the fodder\grass for their livestock. The given result is presented in the table.

Table 5.9: Distribution of Respondents by Collection of Fodder\Grass

Collection of Fodder\Grass	Frequency	Percentage
Farm land	64	62.00
Community forest	0	0.00
National park	4	4.00
No idea	35	34.00
Total	103	100.00

Source: Field Survey 2006

Table 5.9 shows that most of the respondents collect fodder and grass from the farm land. Out of 103 respondents, 62 percent of the respondents collect fodder and grass from farm land because they do not enter in the National Park for the fodder and grass collection. If the Park's authority saw them in the park, they give punishment as well as paid fine too.

Four percent of the respondents are dependent on National park because they have no farm land for fodder and grass collection. The collection of grass and fodder is not easy and they have usually stolen the grass and fodder. While 34 percent of the respondents have no livestock so they do not have any idea about the collection of fodder and grass and there is no community forest in the study area.

Figure 5.9: Sample of Respondents by Collection of Fodder\Grass

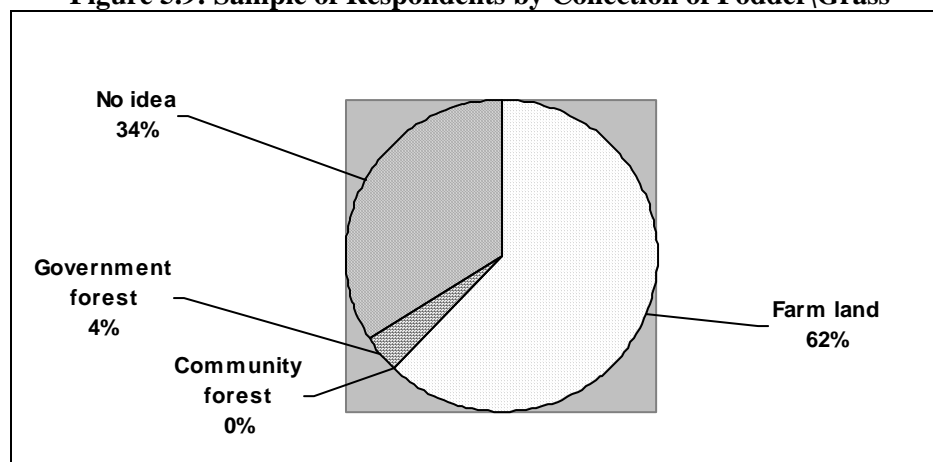

Based on: Table 5.9

5.2.2. Local Forest before Establishment of National Park

In an attempt to determine the situation of local forest before the establishment of the National Park, respondents are asked the questions about the situation of local forest; the result is presented in the table.

Table 5.10: Situation of Local Forest

Situation of Forest	Frequency	Percentage
Dense	38	37.00
Sparse	49	47.00
No change	13	13.00
No idea	3	3.00
Total	103	100.00

Source: Field Survey 2006

Figure 5.10: Situation of Local Forest before Establishment of National Park

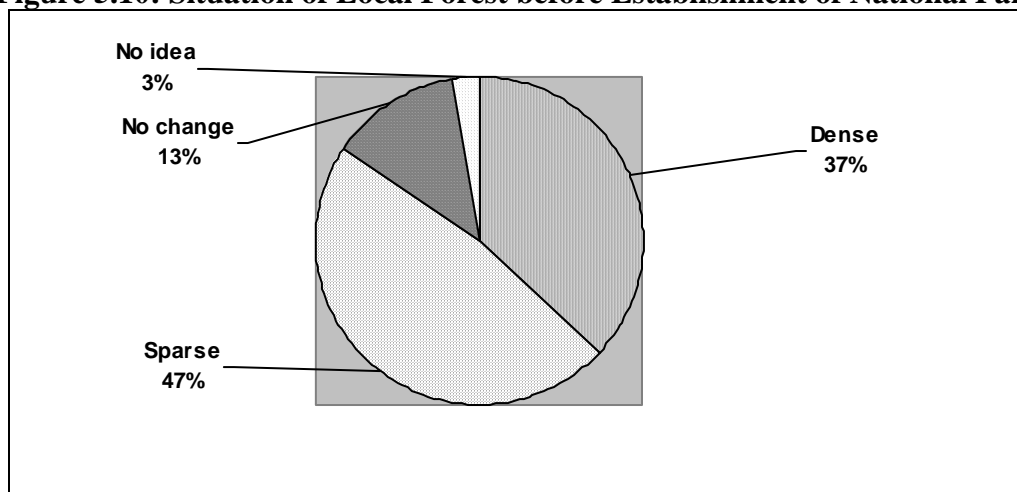

Based on: Table 5.10

Table 5.10 reveals, 47 percent of the respondents said that forest has been sparse before establishment of the National Park, 37 percent of the respondents said that the forest was dense and 13 percent replied that the forest has neither be increased nor be decreased while 3 percent of the respondents answered that they are unknown about the forest because they are new generations and also migrated from others places.

Only after 2002, the forest area was declared as National Park and the time for evaluation has not sufficient. Local people feel that the forest is not their property and they first attack forest to fulfill their needs. Although, the forest has been remaining with a good crown cover, banding in forest resources forced the local communities to illegal encroachment for fulfillment of their requirements.

5.2.3. Energy Sources

The people were heavily dependent upon the forest fuel wood. Firewood mostly used for the cooking purposes of the households. The following figure shows the fuel used for energy purpose.

Table 5.11: Fuel Used for Energy Purpose

Fuel used for Energy purpose	Frequency	Percentage
Falling stem of tree	66	64.00
Straw, dehydrated herbs, shrubs	2	2.00
By cutting trees	2	2.00
Others	28	27.00
Own land	5	5.00
Total	103	100.00

Source: Field Survey 2006

Figure 5.11: Fuel Used for Energy Purpose

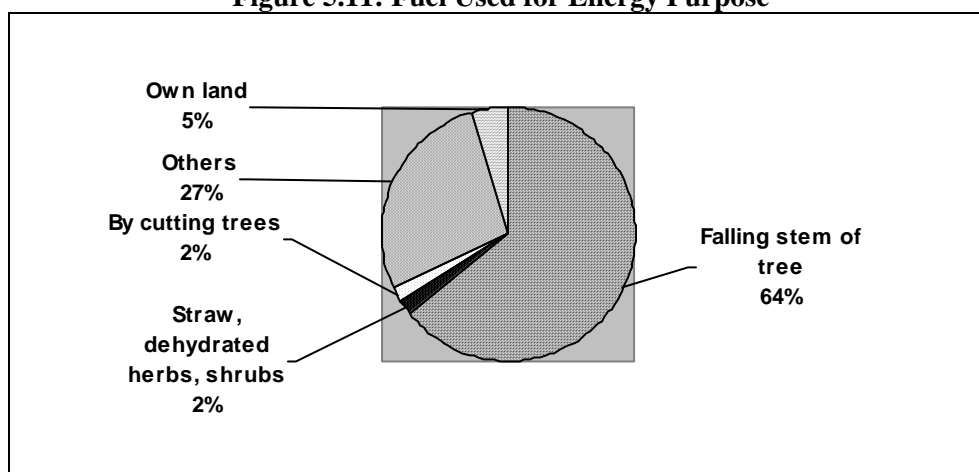

Based on: Table 5.11

Figure 5.11 shows that 64 percent of the respondents of Budhanilkantha Area have used falling stem of tree as firewood for cooking purpose, 27 percent of the respondents have used other sources as fuel for cooking i.e. LPG-gas, kerosene stove, heater etc. this is because Budhanilkantha is near to the Kathmandu city area and there is very difficult to get firewood from the National Park. Only 5 percent of the respondents have used firewood from their own land. The respondents have used only cutting trees and straw dehydrated herbs; shrubs are same in percentage i.e. 2 percent of each.

Hence majority of the respondents were fully dependent upon the firewood for their fuel requirement.

5.2.4 Wood Used For Cooking Purpose per Day

Wood is another necessary fuel or energy to cook food. But there is lacking alternative source of firewood. So, trees, crops and livestock are the integral parts of the complex farming system in Nepal (Denholm, 1991). To cope with this, people still try to poach firewood from the forest area.

Table 5.12: Respondents Used Wood for Cooking Purpose

Wood used for cooking	Frequency	Percentage
Less than 10 kg	73	71.00
Less than 20 kg	4	4.00
Less than 30 kg	0	0.00
No used of wood	26	25.00
Total	103	100.00

Source: Field Survey 2006

Figure 5.12: Wood Used for Cooking Purpose per Day

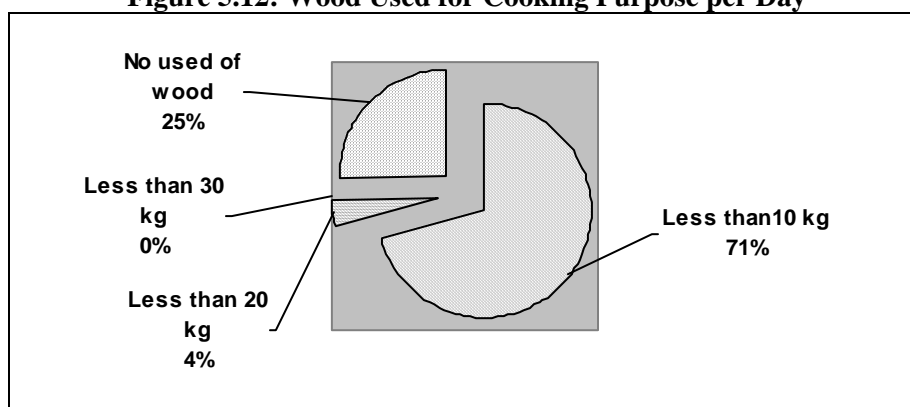

Based on: Table 5.12

Figure 5.12, Out of 103 respondents, 71 percent of the respondents have used firewood less than 10 kg per day cooking food while 25 percent of the respondents have not used firewood but they used LPG- gas, Kerosene stove, for the cooking food. Only 4 percent of the respondents have used firewood less than 20 kg per day because these respondents have large family size. There is no respondent who have used firewood less than 30 kg for cooking food.

5.2.5 Collection of Firewood

To assess the sources of information on collection of firewood, a question was asked, "How much firewood you collect from the park." figure 5.13 gives detailed information on this topic.

Table 5.13: Collection of Firewood per Day from Park

Collection of Firewood per day	Frequency	Percentage
Less than 10 kg	30	29.00
Less than 15 kg	1	1.00
Less than 20 kg	5	5.00
No collection	67	65.00
Total	103	100.00

Source: Field Survey 2006

Figure 5.13: Collection of Firewood per Day from Park

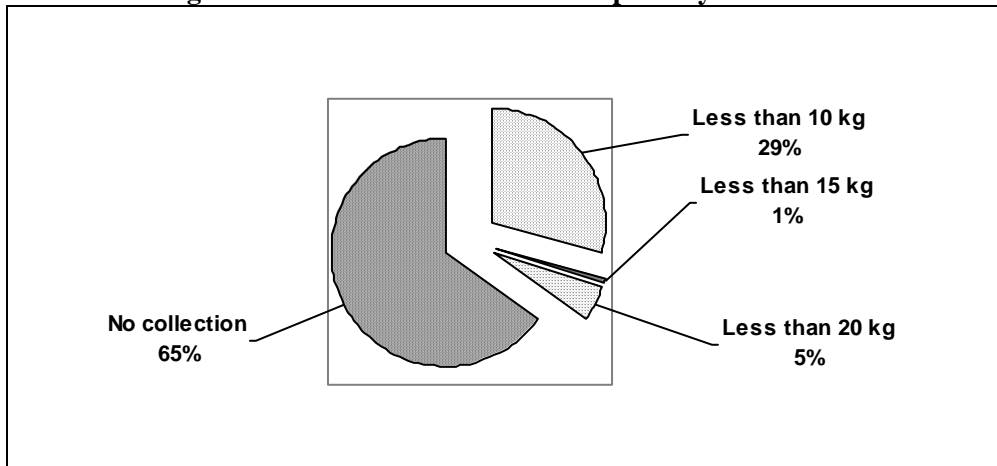

Based on: Table 5.13

Figure 5.13 shows that out of 103 respondents, 65 percent of the respondents were not collected firewood from the park because they did not use wood as fuel. In this area, majority of respondents used other sources for the cooking purpose. 29 percent of the respondents were collect firewood less than 10 kg from the park. 5 percent of the respondents were collect less than 20 kg by stealing from the park and only 1 percent of the respondents was collect firewood less than 15 kg from the park. The firewood collect from the park is very dangerous for the local people to fulfill their requirements. When the park staffs arrest them at the time of collecting firewood, they punished them.

5.2.6 Convenient to Get Firewood after Establishment of SNP

Firewood collection from the National Park is very difficult for the respondents living near the Park area. When researcher asked the question to the respondents, collection of firewood from the Park, the researcher found the following result, which is shown in figure 5.14

Table 5.14: Firewood after Establishment of SNP

Convenient to get firewood	Frequency	Percentage
No change	18	17.00
Easy	6	6.00
Hard	39	38.00
No idea	40	39.00
Total	103	100.00

Source: Field Survey 2006

Figure 5.14: Convenient to get Firewood after the Establishment of SNP

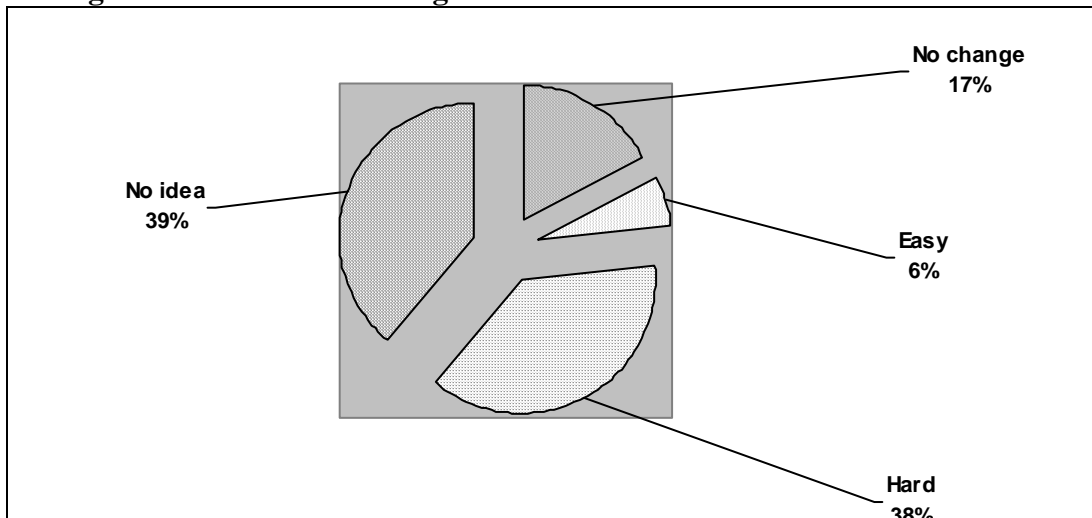

Based on: Table 5.14

Figure 5.14 determines that out of 103 respondents, 39 percent of the respondents have no idea about the collection of firewood from the park is convenient or hard, 38 percent of the respondents said they get hard to get firewood because of the strict rules and regulations of the parks. 17 percent of the respondents have not found any change before and after the establishment of NP and 6 percent of the respondents have found the easy to get firewood after establishment of the NP.

5.2.7 Selling Firewood\Timber in the Market

The researcher took an opinion survey of the respondents regarding the selling firewood or timber in the market. Their responses have been presented in figure below.

Table 5.15: Respondents Selling Firewood in the Market

Selling in Market	Frequency	Percentage
Yes	10	10.00
No	91	88.00
No answer	2	2.00
Total	103	100.00

Source: Field Survey 2006

Figure 5.15: Selling Firewood\Timber in the Market

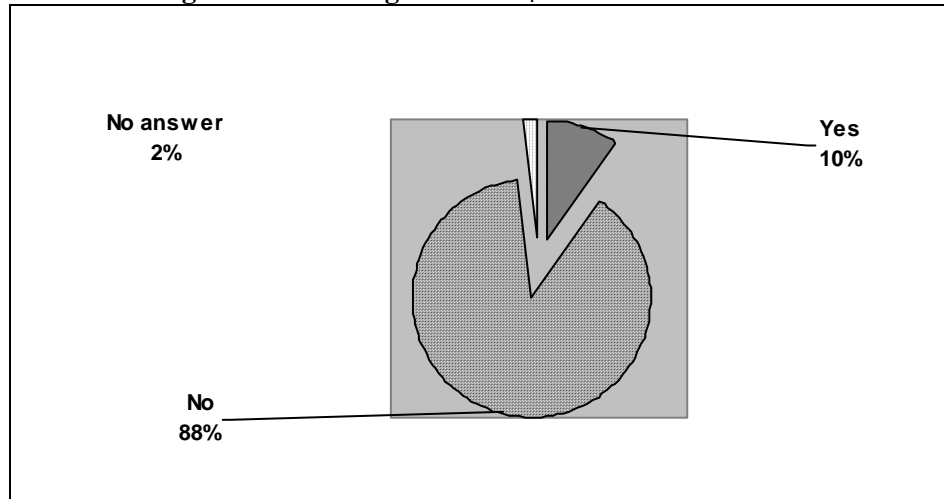

Based on: Table 5.15

Figure 5.15 shows that 88 percent of the respondents were not selling firewood in the market because the firewood is not sufficient for their own use, 10 percent of the respondents were selling firewood in the market because they are labor from which they earn money to sustain their life. 2 percent of the respondents were not give answer about this question. Most of the respondents stole firewood from the Park and afraid with the researcher.

5.3 Perception of Respondents about the National Park

5.3.1 Living Condition Improved after the Establishment of SNP

The respondents were asked the question to identify their perception about the improvement of their living condition after the establishment of SNP. The respondents' have negative attitude, which shows in the table 5.16

Table 5.16: Distribution of Respondents about the Living Condition

Improvement	Frequency	Percentage
Yes	33	32.00
No	66	64.00
No idea	4	4.00
Total	103	100.00

Source: Field Survey 2006

Figure 5.16: Improvement of Living Condition after the Establishment of SNP

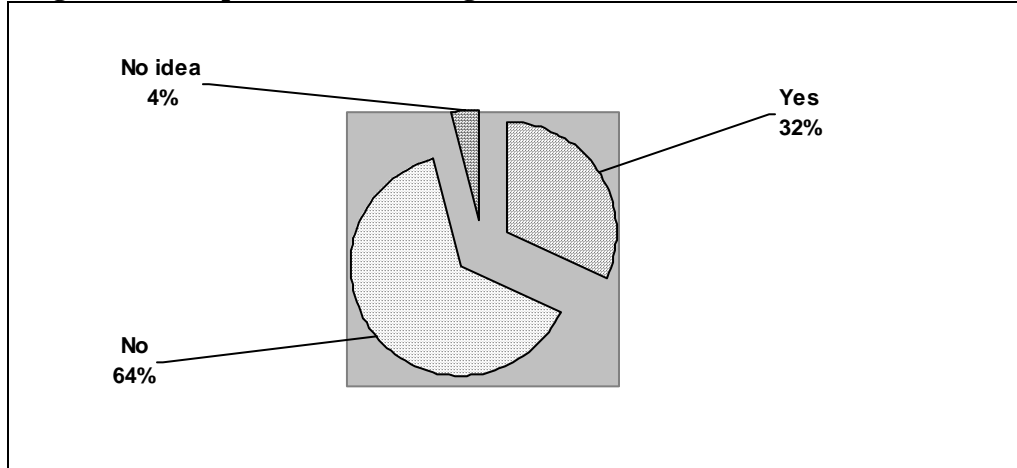

Based on: Table 5.16

Table 5.16 depicts that 64 percent of the respondents said that there were no changes in the living style in this area while 32 percent showed positive attitude about the improvement of living condition of people. Only 4 percent of the respondents have no idea about the improvement of the living condition after the establishment of National Park.

5.3.2 Tourist Amenities

Tourism is the major importance to Nepal's economy, so one of the original reasons for the establishment of the country's national parks and reserves was to encourage tourism; but conservation must remain the prime objective. Tourism must be encouraged to the extent that it is detrimental to the park's integrity.

Tourism in national parks is considered essential but it should be subjected to be control. Visitors should be allowed for observation and appreciation, and recreational activities should be restricted so as not to damage the environment. Visitors should be dispersed throughout the park to control over-utilization of one area and visual and ecological effects of tourist facilities should be minimized.

Table 5.17: Increased In Tourists Number after the Establishment of Park

Tourists Number	Frequency	Percentage
Yes	54	52.00
No	45	44.00
No idea	4	4.00
Total	103	100.00

Source: Field Survey 2006

Figure 5.17: Number of Tourists after the Establishment of Park

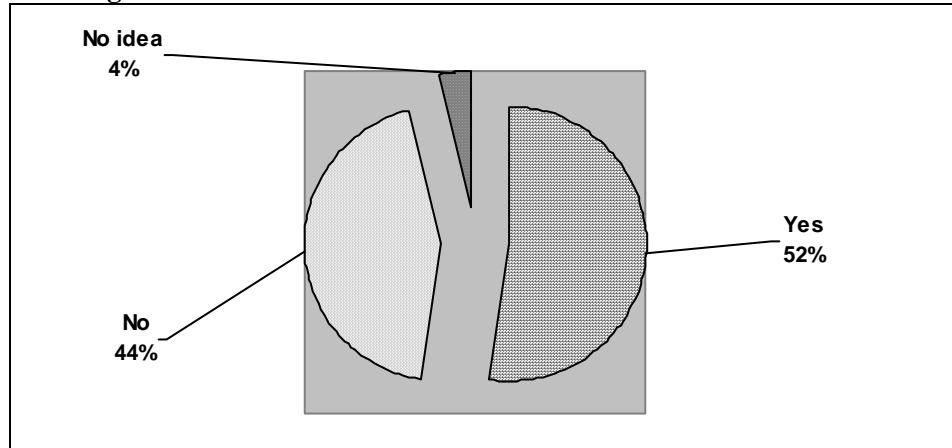

Based on: Table 5.17

Figure 5.17 shows that majority, 52 percent of the respondents were showed the positive attitude about the increasement of tourist. 44 percent of the respondents showed negative attitude about the number of tourists increased after the establishment of National Park and 4 percent of the respondents were unknown about the increased and decreased of the tourists' number.

5.3.3 Local Economy after Establishment of SNP

Economy is crucial components for the development of the area. To know, the perception of the people about change in local economy after the establishment of SNP, the detailed information responded by the respondents concerning about local economy is confined the table 5.18

Table 5.18: Respondents' Perception about the Local Economy

Change in Local Economy	Frequency	Percentage
Yes	13	13.00
No	88	85.00
No idea	2	2.00
Total	103	100.00

Source: Field Survey 2006

Table 5.18 represents that out of total 103 respondents, 85 percent of the respondents were said that there was no change in local economy. Similarly 13 percent of the respondents were said that there was some change in local economy and only 2 percent of the respondents were said that they have no idea about the change in local economy after the establishment of the National Park.

Figure 5.18: Change in Local Economy after the Establishment of SNP

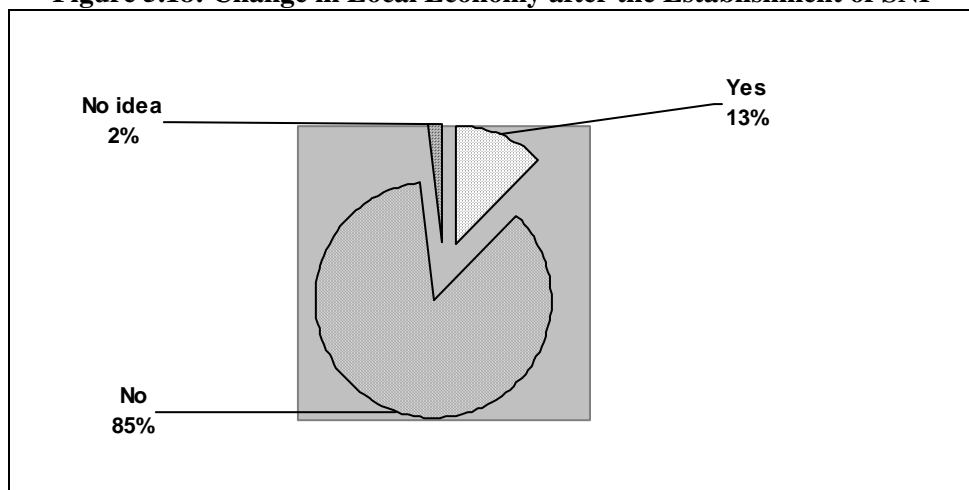

Based on: Table 5.18

1.3.4 Income Level of after Establishment of SNP

The researcher made an attempt to know the income level of respondents after the establishment of SNP. The respondents were asked the question whether the income level is increased or not. The detailed information responded by them is confined in table 5.19

Table 5.19: Respondents' Level of Income after Establishment of SNP

Level of Income	Frequency	Percentage
Yes	11	11.00
No	92	89.00
Total	103	100.00

Source: Field Survey 2006

Table 5.19 reveals that there is no positive response about the increased in income level of the local people after the establishment of SNP. 89 percent of the respondents have no positive response about increased in income level while 11 percent of the respondents have positive attitude about the increased in income level after the establishment of National park.

Figure 5.19: Level of Income after Establishment of SNP

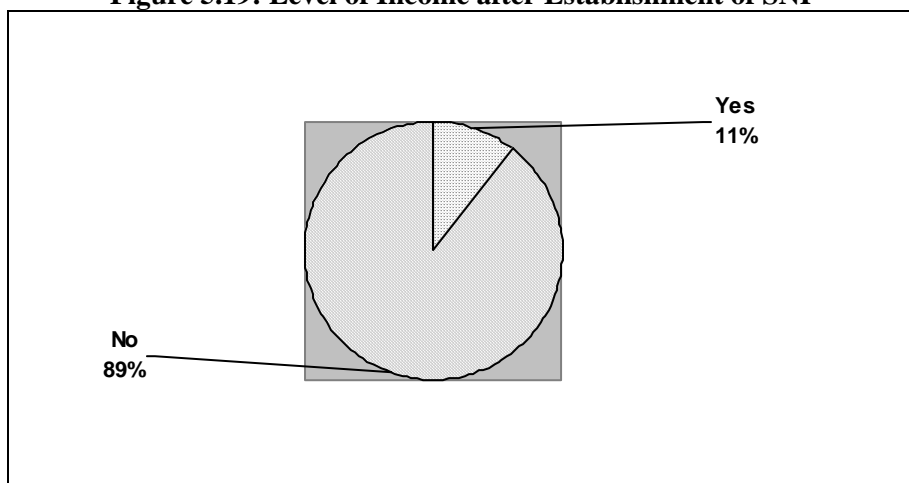

Based on: Table 5.19

5.3.5 Satisfied With Present Condition of SNP

The researcher made an attempt to know the level of satisfaction with present condition of SNP. The researcher asked question to the respondents whether they satisfied with the present condition of SNP. The responses given by them are confined in Table 5.20

Table 5.20: Respondents Level of Satisfaction with Park

Level of Satisfaction	Frequency	Percentage
Yes	82	80.00
No	21	20.00
Total	103	100.00

Source: Field Survey 2006

The above table determines that the majority of the respondents were satisfied with the present condition of the National Park. 80 percent of the respondents were very satisfied with the establishment of National Park because they got fresh air and drinking water. The study area's environment is very pleasant so they said that we are very blissful about the National Park while 20 percent of the respondents were not satisfied with the present condition of the National Park.

Figure 5.20: Respondents Level of Satisfaction

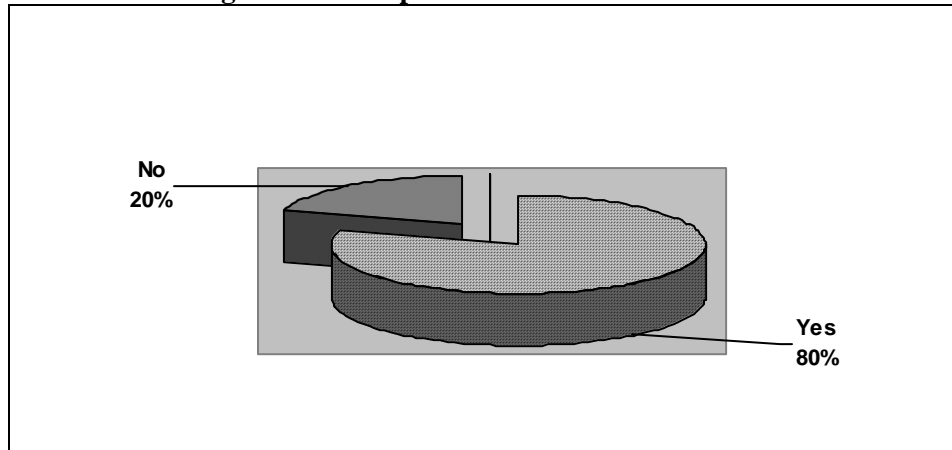

Based on: Table 5.20

5.3.6 Firewood Fulfilled By the Park

To find out the respondents' perception regarding this issue, they were asked whether the firewood fulfilled by the park. The responses are contained in the table 5.21

Table 5.21: Firewood Fulfilled by the Park

Firewood fulfilled by Parks	Frequency	Percentage
Yes	26	25.00
No	69	67.00
No idea	8	8.00
Total	103	100.00

Source: Field Survey 2006

Table 5.21 indicates that, 67 percent of the respondents were answered that the park do not fulfill their requirements of firewood while 25 percent of the respondents said that the park fulfill their firewood needs and only 8 percent of the respondents have no idea about the firewood fulfillment by the park because they do not used firewood for the cooking purpose.

Figure 5.21: Firewood Fulfilled by the Park

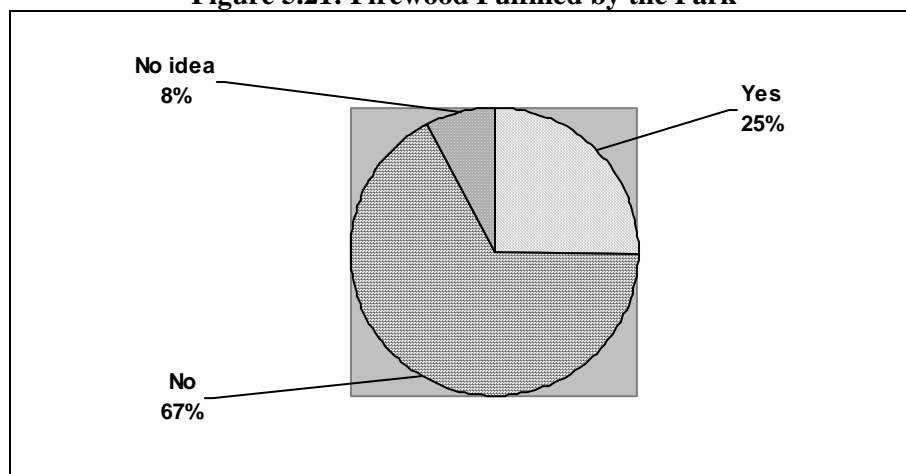

Based on: Table 5.21

5.3.7 About the Park's Rules

In order to find out the respondents' opinion about the park's rules, a question has been asked and the responses are summarized in the table 5.22.

Table 5.22: Respondents Know the Park's Rules

Park's rule	Frequency	Percentage
Yes	16	16.00
No	45	43.00
To some extent	42	41.00
Total	103	100.00

Source: Field Survey 2006

Table 5.22 shows that 43 percent of the respondents were unknown about the park's rules while 41 percent of the respondents were know park's rule to some extent i.e. if they enter in park the security give punishment, they have to paid fine which is very high for the local people. Only 16 percent of the respondents were familiar with the park's rules and regulations.

Figure 5.22: Respondents Know the Park's Rules

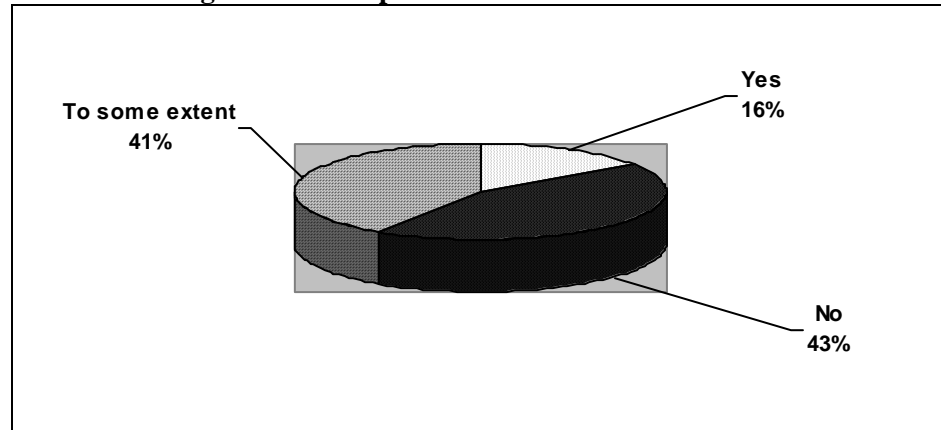

Based on: Table 5.22

5.4 Areas of Conflict

5.4.1 Crops Damaged by Wild Animal

Crops damaging are a common phenomenon near the SNP area. The wild animals such as wild boar, monkeys, porcupine, deer, wild dogs etc are the dangerous for the damage of crops. When the researcher asked respondents about crops damaged by the wild animals. The researcher found the following result, which is shown in table 5.23.

Table 5.23: Crops Damaged by the Wild animals

Damaged Crops by Wild animals	Frequency	Percentage
Yes	19	18
No	67	65
No idea	17	17
Total	103	100

Source: Field Survey 2006

From the above mentioned table, out of 103 the respondents, 18 percent of the respondents are suffering from the crops damaged by wild animals, 65 percent of respondents are not suffering from the wild animals because their land is far from the National Park and wild animals do not reach in their land to destroyed the crops.17 percent of the respondents have no idea about the crops damaged by the wild animals this because either they have landless or their land is far from the Park.

This data shows that the wild animals do not destroy their crops because their land is far from the park or land is in middle of the settlements.

Figure 5.23: Crops Damaged by the Wild animals

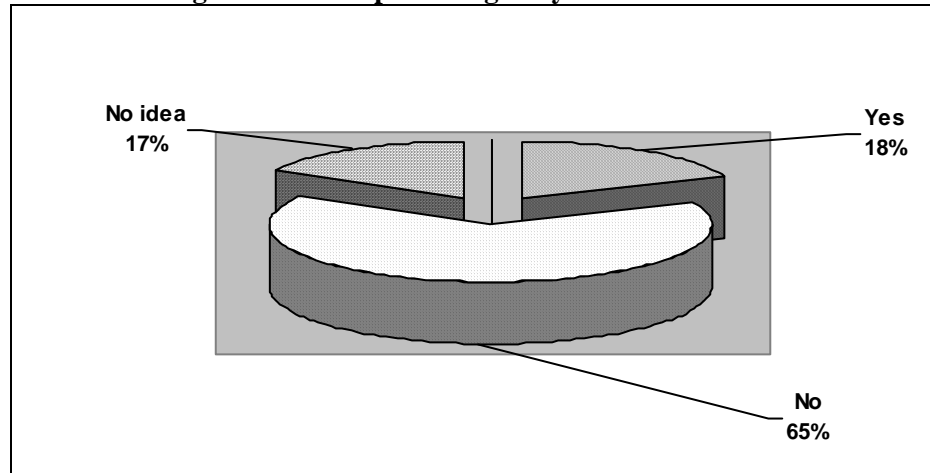

Based on: Table 5.23

Box 5.1 Cause of the conflict

The people of Budhanilkantha area were affected mainly by monkey and wild boar comes from the Park. They told that the attack of the monkey is severing because they are coming in groups and destroy the crops of large area at a single time. The attack of the wild boar is also danger; they eat the much of the crops. Besides, these they were plugging on the planted field and uprooted the planted crops. According to the respondents, the frequency of visiting in crops of the wild boar is higher than others. The attack of porcupine is not severing in the study area.

5.4.2 Grazing Problem

A survey was conducted to get the information about the grazing problem of livestock of the respondents near the National Park. The information obtained from the field visit is presented below in the table 5.24

Table 5.24: Problem Faced by the Respondents

Grazing Problem	Frequency	Percentage
Yes	35	34.00
No	56	54.00
No livestock	12	12.00
Total	103	100.00

Source: Field Survey 2006

Table 5.24 show, that 34 percent respondents have grazing problems in this area and 54 percent of respondents do not have any grazing problems because of few livestock and they feed their livestock from the fodder\grass of their own farm land and 12 percent of the respondents have no livestock in the area.

Figure 5.24: Sample of Respondents by Grazing Problem

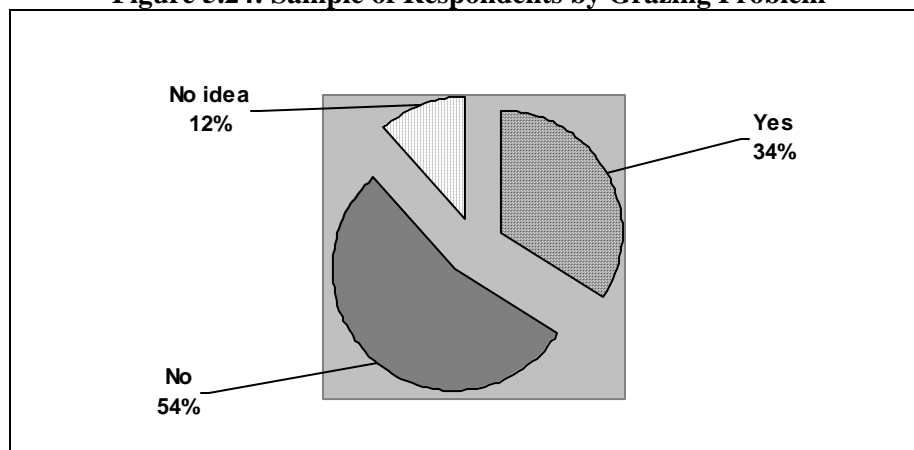

Based on: Table 5.24

5.4.3 Opinion of the Respondents Regarding to Close the National Park

The researcher took an opinion survey of the respondents regarding to close the National Park. Their responses have been presented in table 5.25

Table 5.25: Respondents' Opinion to Close the National Park

Park to be Closed	Frequency	Percentage
Yes	7	7.00
No	96	93.00
Total	103	100.00

Source: Field Survey 2006

Table 5.25 shows the majority (93%) of the respondents said that they did not want to close park because most of the respondents desire to live nearby the park due to its raising importance and fostering the scope of the tourism and they got pure drinking water in this study area. Only 7 percent of the respondents gave arguments against the national park because they could not take and receive any direct benefit through the tourism business and the park authority from the forest resources.

Figure 5.25: Opinions of the Respondents Regarding to Close the National Park

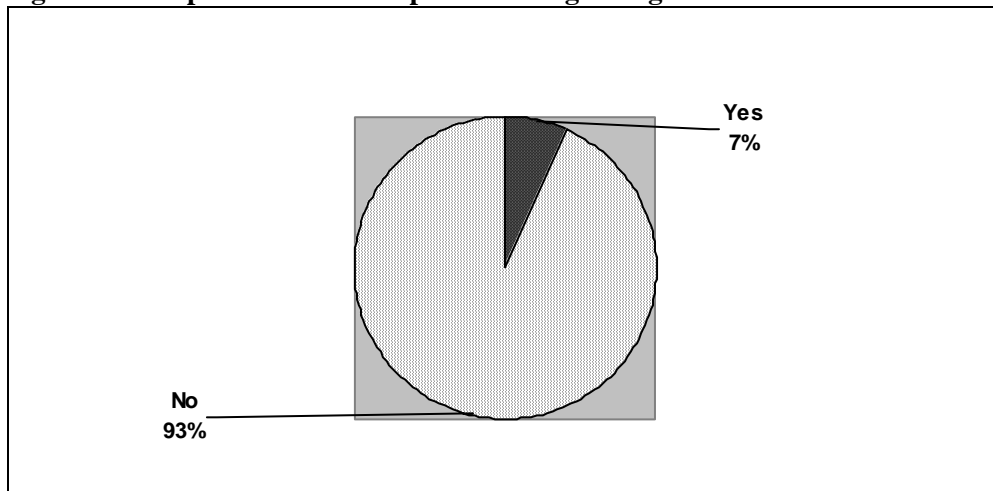

Based on: Table 5.25

5.4.4 Park's Rule

The researcher put the question, to the respondents living in and around the Shivapuri National Park of Budhanilkantha area, has been facing punishment from the park staff. The detailed information responded by the respondents concerning about the park's rule is confined the figure 5.26.

Table 5.26: Respondents Disobey of the Park's Rule

Disobey the Park's Rule	Frequency	Percentage
Yes	0	0.00
No	43	41.00
Forgiven	17	17.00
Punished	26	25.00
No answer	17	17.00
Total	103	100.00

Source: Field Survey 2006

Figure 5.26: Respondents Disobey of the Park's Rule

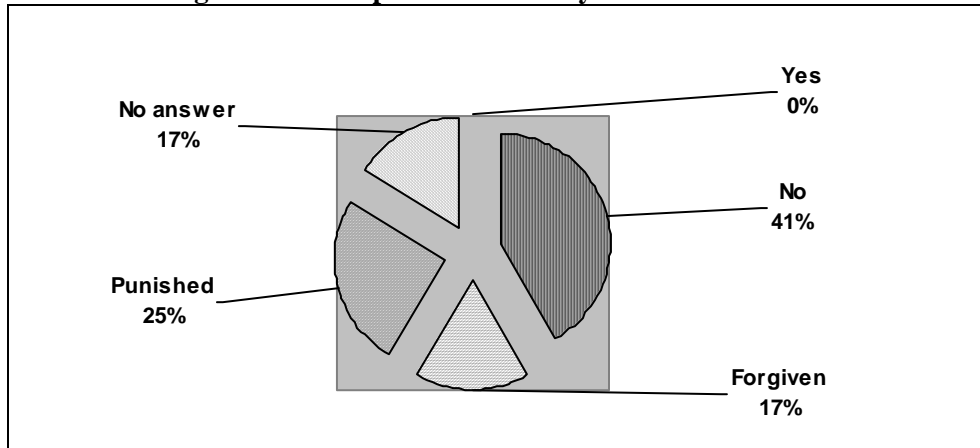

Based on: Table 5.26

Figure 5.26 show that 41 percent of the respondents have not disobeyed the park's rule because they did not enter the park. 25 percent of the respondents were punished by the park's authority. 17 percent of the respondents were forgiven when they entered into the park for the fulfillment of their requirements. It relied on the nature of entrance whether it is harmful to flora and fauna or not. They mostly fined Rs.50 to 1000 per person. 17 percent of the respondents were not given answer about disobey of the park's rule because they afraid of the parks staff.

SUMMARY, CONCLUSION AND RECOMMENDATIONS

6.1 Summary

The study aimed to find out the respondent's the socio-economic impact of the Shivapuri National Park on the livelihoods of the people living nearby, socio-economic condition of the local people, demand and supply of firewood in Budhanilkantha area, and components of conflicts between the local people and National park. Primary data from Budhanilkantha area has been used in this research study. Altogether 103 respondents were sampled in study. Simple Statistical methods have applied for data analysis. The summary of the finding, conclusion and recommendations of this study are mentioned in this chapter.

- Fifty-five percent of the respondents are male and forty-five percent of the respondents are female.
- Forty-five percent have household size less than 5, who are considered as an ideal household.
- The majority of the respondents, 92 percent are Hindu.
- The majority of the respondents, (62%) are literate which is not satisfactory as compared to the distance from the capital city Kathmandu, although thirty-eight percent of respondents are illiterate because of the low-income level they could not read and write.
- Fifty-four percent are engaged in agriculture as their main occupation.
- Sixty-three percent of the respondents have less than 6 ropani of each land also getting difficult to survive only from its products
- The majority of the respondents (32%) have monthly income between Rs 3000-5000 each which constitutes good earning in comparison to other respondents.
- .Out of 120 livestock, most of the respondents (34%) were keeping goats because it is easy to keep and feed them.
- Sixty-two percent collect fodder and grass from farm land because it is hard to enter in the Park for collection of fodder and grass.
- Forty-seven percent of the respondents said that forest has been sparse before establishment of the National Park.
- The majority of the respondents (64%) were fully dependent upon the firewood for their fuel requirement.

- Most of the respondents, i.e. 71 percent have used firewood less than 10 kg per day for cooking food.
- Sixty-five percent were not collected firewood from the Park because they did not use wood as fuel.
- Thirty-nine percent have no idea about the collection of firewood from the park is convenient or hard.
- Nearly 90 percent of the respondents were not selling firewood in the market because the firewood is not sufficient for their own uses.
- Sixty-four percent of the respondents said that there were no changes in the living style after the establishment of National Park.
- The majority (52%) of the respondents have the positive attitude about the increasement of tourist after the establishment of the National Park.
- Eighty-five percent were said that there was no change in local economy after the establishment of the National Park.
- Nearly 90 percent of the respondents have no positive response about increase in income level after the establishment of National Park.
- Eighty percent of the respondents were very satisfied with the establishment of National Park because they got fresh air and drinking water.
- Sixty-seven percent of the respondents were answered that the park does not fulfill their requirements of firewood.
- Forty-three percent of the respondents were unknown about the park's rules.
- The majority (65%) of respondents are not suffering from the wild animals because their land is far from the National Park and wild animals do not reach in their land to destroy the crops.
- Fifty-four percent of respondents do not have any grazing problems because of few livestock and they fed their livestock from their own farm land.
- Most of the respondents (93%) said that they did not want to close park because most of the respondents desire to live nearby the park due to its raising importance and fostering the scope of the tourism and they got pure drinking water.
- A large number (41%) of the respondents have not disobeyed the park's rule because they did not enter the park.

6.2 Conclusion

On the basis of the above findings, it had been concluded that the majority (93%) of the respondents are satisfied with the establishment of the Shivapuri National Park but the local people living in and around the Shivapuri National Park have no legal access in all available natural resources as their demand although quality is in good condition and has reasonable distance for resource.

Livestock rearing is one of the main sources of income of the local people. Although, fodder/grass and grazing have been banned by the park, 62 percent of the respondents are collecting fodder/grass both from the farm land. The demand of firewood of the people for energy did not fulfill by the Park. Sometimes, people had stolen the firewood and the fodder/grass from Park.

Hence, livestock grazing, crops damage by wild animals and band in resource collection are the main areas of conflicts between the park authority and local people in the study area.

If the livelihood of the local people becomes less vulnerable or no vulnerable, then only park and protected area can get success to protect the natural biodiversity in sustainable way. The future of any park and protected area depend very much on knowledge and capacity to manage.

6.3 Recommendations

6.3.1 Recommendations for Planning

The recent Shivapuri National Park management plan is based on the guidance principles of the management of Bio-diversity which by passes the needs of local people. Hence, there is a need for revising the plan which should meet the demand of local people as well as conservation goal of the park. The management plan should be flexible and reviewed annually to meet the present need of local people as well as future generation. Hence, the park conservation strategy and socio economic development of local people should be go hand in hand.

The following can be recommended:

- Provide forest resources to the local people with the certain costs to the fodder and grass through which they are benefited as well as park staff are generating the income.
- Local people should be encouraged to change their traditional occupation. Government should be trained them in other income generating activities like bee-keeping, fish farming, poultry farming, and tourism industries.

- Fifty percent of the local people need to be participating in all level of park management i.e. from decision making to benefit sharing.
- Educate and show the short-term and long-term benefits of conserving forest and its resources to the local people.
- Awareness raising campaign should be given to local people by the park authority.
- Crops depredation of local farmers have monitored and provide good compensation.
- People living nearby the park area should be transferred other suitable place with giving good compensation from government side.
- Carry out research regularly which helps to review the impact of overall activities of the park area.

6.3.2 Recommendations for Further Research

Some recommendations for further research that is interesting to know the situation in more details are as follows:

- Hunting and poaching activities and its market, consumer and economic value.
- Potential agricultural crops that can be grown on the basis of the topography, soil and water to introduce high value crops.
- Land use and land cover change after the establishment of the SNP.
- The programs and Policies of the Shivapuri National Park and its effectiveness to the people and the park itself.

REFERENCES

- Adhikari, H.P., 1998, "An Assessment of Park People in RSPWR Nepal," M.Sc. thesis, Agricultural University of Norway, Norway.
- Allendorf, T.D., 1999, "Local Residents Perception of Protected Areas in Nepal: Beyond Conflict and Economics", Ph.D.dissertation. University of Minnesota, USA.
- Bajracharya, D., Shrestha , K.K and Chaudhary, R.P., 1997, *Garden Flowers*, KMTNC, Jawalakhel, Lalitpur, Nepal.
- Bajracharya, K.M., 1998, "Economic and Environmental Management of Forests in Nepal: Issues and Problems," In: M.K. Dahal and D.R. Dahal (eds.). *Environment and Sustainable Development: Issues in Nepalese Perspective*. NEFAS, Kathmandu.
- Bajracharya, M.K., 1999, *Nepal –Nature’s Paradise (Insight into Diverse Facets of Topograohy, Flora and Ecology)*, Hillside Press Ltd. Kathmandu.
- Bandar, M, 1998, "Assessing the impact of off road driving on the Masai Mara National Reserve and adjoining area", Kenya, M.Sc. thesis submitted to International Institute for Aerospace Survey and Earth Sciences, the Netherlands.
- Baral, N., 1998, "Wild Boar-Man Conflict: Assessment of Crop Damage by Wild Boar (*Sus scrofa*) in the South-Western Section of Royal Bardia National Park, Nepal." M.Sc. thesis, Department of Zoology, Tribhuvan University, Kirtipur.
- Bolin, B., and R., Sukumar, 2000, "Global Perspective". In: *Land Use Change and Forestry*, Edited by Waston, R., I. Noble, B. Bolin, N. Ravindranath, D. Verardo and D. Dokken. A Special Report of Intergovernmental Panel for Climate Change. Cambridge University Press, Cambridge.
- Burton’s J.W., 1969, *Conflict and communication: The Use of Controlled Communication in International Relations*, Macmillan, London .
- Campbell, M., and Joshi, S., 1978, "Seed Collection times for Afforestation Species in Nepal", Nepal-Australia Forestry Project, Kathmandu, Nepal.

- CBS, 2005, *Statistical Year Book of Nepal*, Central Bureau of Statistics, (CBS), Kathmandu.
- Cooke, P., 1998, "Intrahousehold Labor Allocation Responses to Environmental Good Scarcity: A case Study from the Hills of Nepal" *Economic Development and Cultural Change*, 46(4).
- Coser, L.A., 1967, *Continuities in Study of Social Conflict*, The Free Press. New York.
- DNPWC, 1998, *National Park and Wildlife of Nepal*, A Brochure, Department of National Parks and Wildlife Conservation, Kathmandu.
- DNPWC, 2003, *Biodiversity Conservation Efforts in Nepal*, Wildlife Week 2003.HMG\N. Ministry of Forest and Soil Conservation.
- Fleming, R.L., 1993, *The General Ecology, Flora, Fauna of Midland Nepal*, USAID, Kathmandu.
- Ghimire, M.K., 2000, "Management and Utilization of Forest Product in Buffer Zone Area: A Case Study of Royal Bardia National Park and Buffer Zone Area", M.A. thesis, Department of Sociology-Anthropology, Tribhuvan University, Kathmandu.
- Gyawali, S., 1994, "Conflict of Land Use: Livestock Management and Community Forestry in Bachhauli Village Development Committee Adjacent to Royal Chitwan National Park in Lowland Nepal", Unpublished M.Sc. thesis, Norwegian Agriculture University of Norway, Norway.
- Gyawali, S.R., 1989, "Park - People Conflict: Assessment of Crop Damage and Human Harassment by Rhinoceros (*Rhinoceros unicornis*) in Sauraha Area Adjacent to the Royal Chitwan National Park, Nepal". A thesis submitted in partial fulfillment of the requirement for M. Sc. degree at Agricultural University, Norway.
- IUCN, 1978, *Categories, Objectives and Criteria for Protected Areas*. IUCN, Gland, Switzerland.
- Kasu, B.B., 1996, "Status and Food Habits of Nilgai (*Boselaphus tragocamelus*) in Royal Bardia National Park, Nepal". M. Sc. thesis, Agricultural University of Norway, Norway.

- KMTNC, 1985, *People and Protected Areas in the Hindu Kush-Himalaya. Proceedings of the International Workshop on the Management of National Parks and Protected Area in the Hindu-Kush, Himalaya.* Kathmandu
- Kunwar, K.J. 2003, "Socio-economic condition of Community Based Organization and their Role and Importance in Bio-Diversity Conservation: A Case Study of Makalu-Barun National Park in Sankhuwasava District of Nepal", M.A. thesis, Department of sociology, T.U., Kathmandu.
- Majupuria, T.C. and Majupuria, R.K., 1998, *Wildlife, National Parks and Reserves of Nepal. (Resource and Management)*, India.
- Malla Y.B., 2000, *Impact of Community Forestry Policy on Rural Livelihood and Food Security in Nepal*, Unasylva.
- Milton, J.P., and Binney, G.A., 1980, *Ecological Planning in the Nepalese Terai. A Report on Resolving Resource between Wildlife Conservation and Agricultural Land Use in Padampur Panchayat*, Threshold, International Centre for Environmental Renewal, Washington, D. C.
- Mishra, H. R., 1991, *Regional Review: South and South-East Asia. A Review Developed from a Regional Meeting on National Parks and Protected Areas Held in Bangkok from 1-4 Dec. 1991.* IUCN, AIT and WB.
- Mishra, H.R., 1982, "Balancing Human Needs and Conservation in Nepal's Royal Chitwan National Park," *Ambio* 11 (5)
- Nepal, S.K. and Weber, K.E., 1993, *Struggle for Existence: Park - People Conflict in Royal Chitwan National Park, Nepal.* Asian Institute of Technology, Bangkok.
- NFI, 1998, *State of Natural Resources in Nepal*, FRISP, Kathmandu.
- Oil, K.P., 1998, *Conflict Resolution and Mediation in Natural Resource Management in Nepal*, IUCN, Switzerland.
- Ojha, E.R., 1999, *Dynamics and Development of Highland Ecosystems*, Walden Book House, Kathmandu.

- Paudyal, P.R., 1995, "An Assessment of Crop Depredation due to Wildlife in Shivapuri Watershed and Wild life Reserve," M.Sc. thesis, Department of Zoology. Tribhuvan University, Kathmandu.
- Phuyal, M., 2004, "Protected Area and its Impact on the Livelihood of Local People: A Case Study of Shivapuri National Park", M.A. thesis, Department of Geography, Tribhuvan University. Kathmandu, Nepal.
- Pokhrel, S., 2004, "Resource Accessibility and Park-People Conflicts In and Around the Shivapuri National Park: A Case Study of Sundarijal VDC, Kathmandu", M.A. thesis Department of Rural Development, Tribhuvan University, Kathmandu.
- Rawal, R.S., 1998, "A Study on Problems facing by Local People after the Establishment of Royal Bardia National Park", M.Sc. Thesis, Department of Zoology, T.U., Kathmandu.
- Sharma, U.R., 1990, *An Overview of Park-People Interactions in Royal Chitwan National Park, Nepal*. Abstract; Landscape and Urban Plan.
- Sharma, U.R., 1991, *Park People Interactions in Royal Chitwan National Park, Nepal*. Ph. D. dissertation, The University of Arizona, Arizona.
- Shrestha, R., 2006, *Hamro Kalpabrikshya*, Department of National Park and Wildlife Conservation, Kathmandu.
- Shrestha, R., 2006. *Hamro Kalpabrikshya*, Department of National Park and Wildlife Conservation, Kathmandu.
- Shrestha, T.K., 2003, *Wildlife of Nepal*, R.K Printers, Teku, Kathmandu, Nepal.
- Singh, S.L.etal. (2004) *Watershed Management Case Study Nepal*. Review and Assessment of Watershed Management Strategies and Approaches. Soil and Water Conservation Society.
- Soti J., 1995, "An Assessment of Crop Depredation due to Wildlife in the Neighborhood of Shivapuri Watershed and Wildlife Reserve", M.Sc. thesis Department of Zoology, T.U., Kathmandu.
- Stainton J.D.A., 1972, *Forests of Nepal*, John Murray, London.

- Suwal, R.N., 1993, *Koshi Tappu Wildlife Reserve: Conservation Issues and Management Measures*, A Survey Report Submitted to IUCN, Kathmandu.
- Ulak, N.P., 1992, *Wild boar in Shivapuri Watershed and Management, Shivapuri Integrated Watershed Management Project, GCP/NEP/084/NOR*. National Consultant's report.
- Upreti, B.N., 1985, *The Park People Interface in Nepal Problems and New Direction*; Jeffrey, A. Mc. Neely James W. Thorell and Suresh Chalise (Eds.). People and Protected Area in the Hindu Kush Himalaya, Proceeding of International Workshop on the Management of National Parks and Protected Areas in the Hindu Kush-Himalaya, 6-11May 1985, Kathmandu : KMTNC and ICIMOD.
- WMI/IUCN-Nepal, 1994, *Biodiversity of Koshi Tappu Wildlife Reserve and its Adjacent Area*, Applied Databases for Integrated Biodiversity Conservation in Nepal. Woodlands Mountain Institute / ICUN-Nepal.

Websites

- MOPE 2002, Nepal: National Assessment Report for World Summit on Sustainable Development, Ministry of Population and Environment, Nepal.
<http://www.scdp.org.np/sdan/SDANrpt3.pdf> Retrieved on February 23, 2004
- UNDP/ HMG 2003, Sustainable Community Development Program (Nepal Capacity 21) <http://www.scdp.org.np/sdan/SDANrpt2.pdf> Retrieved on February 23, 2004
- Department of National Parks and Wildlife Conservation 2003, www.dnpwc.gov.np retrieved on February 23, 2004.
- International Institute for Sustainable Development 2004
<http://www.iisd.org> | retrieved on January 11, 2004.
- <http://www.fao.org/>
- <http://www.icimod.org/>
- <http://www.crtnepal.org.np/>
- http://www.fsc.org/*itto.or.jp
- <http://www.fscoax.org>
- http://www.livelihoods.org/info/info_guidancesheets.html.

Appendix - I Photographs



Picture 1: Discussion with the local people



Picture 2: Goat grazing near the farm land



Picture 3: Collection of fodder/grass from own land



Picture 4: Group discussion with the local people



Picture 5: Woman is stealing firewood from the Park.



Picture 6: Forest of Shivapuri National Park

Appendix - II Questionnaire

Socio-economic Impact of Shivapuri National Park on Local Community (A Case Study of Budhanilkantha Area)

A) Demographic and Socio-economic Conditions

Name:	
Caste/Ethnicity:	Gender:
No. of Family member	Education:

1. What is your occupation?

Agriculture Labors Service Industry Others

2. How much land do you have?

Land type	Area
Cultivated	
Non-Cultivated	

3. Monthly Income (Rs.)

0-1000 1000-3000 3000-5000 5000 and above

4. Do you have Livestock? If Yes,

Livestock Type	Number
Cow	
Buffalo	
Goat	
Pig	
Chicken	
No livestock	

B) Natural Accessibility

1. From where do you collect the fodder/grass?

Before the establishment of NP	After establishment of NP
Farm land	Farm land
Community forestry	Community forestry
National Park	National Park
No idea	No idea

2. What was the situation of the local forest before the establishment of National Park?

Dense Sparse No change No idea

3. What types of wood were using for energy purpose?
 Falling stem of tree
 Straw, dehydrated herbs, shrubs
 By cutting trees
 Others
 Own land
4. How much wood do you need per day for cooking purpose?
 Less than 10 kg Less than 20 kg Less than 30 kg No used of wood
5. How much firewood would you collect from the Park in a day?
 Less than 10 kg Less than 25 kg Less than 20 kg No collection
6. Do you find convenient to get firewood after establishment of SNP?
 No change Easy Hard No idea
7. Do you sell firewood and timber in the market?
 Yes [] No [] No answer []
9. Are there any alternatives that you use for the problem of firewood?

C) Perception of Respondents about the National Park

1. Has your living condition improved after the establishment of Shivapuri National Park?
 Yes [] No [] No idea []
2. Has the tourist number increased after the Park was opened?
 Yes [] No [] No idea []
3. Are there any changes in the local economy after the implementation of Shivapuri National Park in your village? If yes, mention the changes.
 Yes [] No [] No idea []
4. Does Shivapuri National Park help to increase your income level?
 Yes [] No []
5. Are you satisfied with present condition of Shivapuri National Park?
 Yes [] No []
6. Is your firewood requirements fulfilled from the Park?
 Yes [] No [] No idea []
7. If you sell how much per month?
8. How much money do you earn from that sale?

9. Do you know about the Park's rule?
 Yes
 No
 To some extent
10. What kind of help do you get from the Shivapuri National Park authority?
11. How is the relationship between the park staff and the local people?
12. Do you think that the park rule has to be changed?

D) Areas of Conflict

1. Is your land or crops affected by rivers, droughts or wild animals?
 Yes No
2. Do you have grazing problem?
 Yes [] No []
3. Which is the season in which livestock grazing problem is most critical?
 Winter Hot Monson
4. Do you want the Park to be closed?
 Yes [] No []
5. If you disobey the Park rules and cut the wood is you punished or forgiven by park staff?
 Yes [] No [] Punished [] Forgiven [] No answer []