



TRIBHUVAN UNIVERSITY
INSTITUTE OF ENGINEERING
PULCHOWK CAMPUS

THESIS NO: M-358-MSREE-2008-2023

Techno-Economic Analysis of Solar Mini Grid

A Case Study of Mikawakhola Rural Municipality-4, Dalaicha Danda, Taplejung

by

Milan Raj Ranjitkar

A THESIS
SUBMITTED TO THE DEPARTMENT OF MECHANICAL AND
AEROSPACE ENGINEERING
IN PARTIAL FULFILLMENT OF THE REQUIREMENTS FOR THE
DEGREE OF MASTER OF SCIENCE IN RENEWAL ENERGY
ENGINEERING

DEPARTMENT OF MECHANICAL AND AEROSPACE ENGINEERING
LALITPUR, NEPAL

August, 2023

COPYRIGHT

The author has agreed that the library, Department of Mechanical and Aerospace Engineering, Pulchowk Campus, Institute of Engineering may make this report freely available for inspection. Moreover, the author has agreed that permission for extensive copying of this project report for scholarly purpose may be granted by the professor(s) who supervised the project work recorded herein or, in their absence, by the Head of the Department wherein the project report was done. It is understood that the recognition will be given to the author of this report and to the Department of Mechanical and Aerospace Engineering, Pulchowk Campus, and Institute of Engineering in any use of the material of this project report. Copying or publication or the other use of this report for financial gain without approval of the Department of Mechanical and Aerospace Engineering, Pulchowk Campus, Institute of Engineering and author's written permission is prohibited. Request for permission to copy or to make any other use of the material in this report in whole or in part should be addressed to:

Head,

Department of Mechanical and Aerospace Engineering

Pulchowk Campus, Institute of Engineering

Pulchowk, Lalitpur

Nepal

TRIBHUVAN UNIVERSITY
INSTITUTE OF ENGINEERING
PULCHOWK CAMPUS

DEPARTMENT OF MECHANICAL AND AEROSPACE ENGINEERING

The undersigned certify that they have read, and recommended to the Institute of Engineering for acceptance, a thesis report entitled "Techno-Economic Analysis of Solar Mini Grid: A Case Study of Mikawakhola Rural Municipality-4, Dalaicha Danda, Taplejung" submitted by Milan Raj Ranjitkar in partial fulfillment of the requirements for the degree of Master of Science in Renewal Energy Engineering.



Supervisor, Dr. Ajay Kumar Jha
Associate Professor
Department of Mechanical and Aerospace Engineering

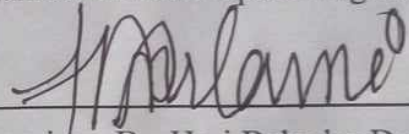

Supervisor, Dr. Hari Bahadur Darlami
Associate Professor & Coordinator (MSREE)
Department of Mechanical and Aerospace Engineering



External Examiner, Dr. Doleshwar Koirala
Director, Nepal Airlines Corporation

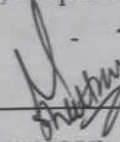

Committee Chairperson, Dr. Sudeep Bhattarai
Head of Department
Department of Mechanical and Aerospace Engineering



Date: August 06, 2023

ABSTRACT

The Dalaicha Danda Solar Mini Grid is the subject of a thorough techno-economic analysis in this thesis, which serves as a case study for evaluating the practicality and advantages of solar-powered micro grid systems in off-the-grid and underserved areas. The goal of the study is to assess the small grid's technical merits, financial viability, and socioeconomic effects, offering important insights into the viability of such projects as an alternative to traditional grid growth. Interested in implementing solar mini grid initiatives in comparable settings, ultimately helping to realize the aims of universal energy access and sustainable development. A thorough analysis of the literature already on solar mini grids is conducted at the outset of the study to examine how they might improve energy access, foster sustainable development, and combat climate change. In the case study of the isolated and off-grid community of Dalaicha Danda, the technical aspects of the solar mini grid, such as the solar panels, battery storage, power conversion systems, and distribution network, were thoroughly evaluated on-site.

The financial viability of the project is also evaluated using a comprehensive economic analysis that considers the original capital expenditure, ongoing operations and maintenance expenses, income generation, and payback times. Through community surveys and interviews, socio-economic effects like enhanced livelihoods, educational opportunities, and healthcare services are also assessed. The outcomes show that the Dalaicha Danda Solar Mini Grid demonstrates to be a technically possible and economically viable solution, providing a continuous and stable electricity supply to the community. The analysis shows that solar mini grids can dramatically raise living standards in rural areas while promoting sustainable development and economic prosperity. Policymakers, investors, and energy experts interested in implementing solar mini grid projects in related situations can learn a lot from the case study's findings, which will ultimately help us achieve our goals of universal energy access and sustainable development.

ACKNOWLEDGMENTS

I extend my profound gratitude and heartfelt appreciation to all those who have contributed to the successful completion of this thesis on "Techno-Economic Analysis of Solar Mini Grid: A Case Study of Mikawakhola Rural Municipality-4, Dalaicha Danda, Taplejung." This research journey has been enriching and rewarding, and I am indebted to numerous individuals and institutions for their invaluable support and guidance.

First and foremost, I would like to express my deepest gratitude to my two supervisors, Associate Professor Dr. Ajay Kumar Jha and Associate Professor Dr. Hari Bahadur Darlami for supervising and guiding me in accomplishing my thesis. Their unwavering support, insightful feedback, and scholarly guidance have been instrumental in shaping this thesis. I am truly fortunate to have had the privilege of working under their mentorship. Their expertise, encouragement, and commitment to excellence have inspired me to push my boundaries and strive for academic excellence.

I am also immensely grateful to the entire faculty and staff of Department of Mechanical and Aerospace Engineering, Center for Energy Studies for their help and inspiration in due course. Their dedications to fostering a conducive academic environment and their willingness to share knowledge have been instrumental in enriching my research experience.

I would like to extend my sincere thanks to the residents of Dalaicha Danda for their warm hospitality and cooperation during the data collection phase of this study. Their willingness to share their experiences and insights has been invaluable in understanding the local context and energy needs of the community.

I am indebted to my family for their unwavering love, encouragement, and belief in my abilities throughout this journey. Their constant support has been my source of strength and motivation during challenging times.

Lastly, I want to thank my friends and colleagues for their camaraderie and moral support throughout the research process. Their constructive discussions and encouragement have been a significant source of inspiration.

TABLE OF CONTENTS

| | |
|---|-------------|
| COPYRIGHT | i |
| APPROVAL PAGE | ii |
| ABSTRACT | iii |
| ACKNOWLEDGMENTS | iv |
| TABLE OF CONTENTS | v |
| LIST OF TABLES | viii |
| LIST OF FIGURES | ix |
| LIST OF ABBREVIATIONS | x |
| CHAPTER ONE: INTRODUCTION | 1 |
| 1.1 Background | 1 |
| 1.2 Statement of the Problem..... | 3 |
| 1.3 Objectives | 4 |
| 1.3.1 Main objective | 4 |
| 1.3.2 Specific objectives | 4 |
| CHAPTER TWO: LITERATURE REVIEW | 5 |
| 2.1 Solar Mini Grid Sector in Nepal | 5 |
| 2.2 Technical Aspects of Solar PV Systems | 9 |
| 2.3 Socio-Economic aspect of solar mini grid | 9 |
| 2.4 Solar mini grid system researched Direction. | 11 |
| CHAPTER THREE: RESEARCH METHODOLOGY | 17 |
| 3.1 Literature review | 18 |
| 3.2 Site Survey | 18 |
| 3.3 Technical Analysis of solar Mini Grid..... | 18 |
| 3.3.1 Number of Solar Arrays (N) | 18 |
| 3.3.2 Capacity of Battery Bank (B) | 19 |

| | |
|--|-----------|
| 3.3.3 DoD (Depth of Discharge)..... | 19 |
| 3.4 Economic Analysis of solar Mini Grid | 20 |
| 3.4.1 Simple payback period..... | 20 |
| 3.4.2 Net Present Value (NPV)..... | 20 |
| 3.4.3 Internal Rate of Return (IRR) | 21 |
| CHAPTER FOUR: RESULTS AND DISCUSSION..... | 22 |
| 4.1 Locations..... | 22 |
| 4.2 Energy Survey Output of Dalaicha Danda..... | 23 |
| 4.2.1 Energy Interventions..... | 24 |
| 4.2.2 Willingness to Pay | 24 |
| 4.2.3 Energy Resource Assessment | 25 |
| 4.2.4 Energy demand and Projection Analysis | 26 |
| 4.3 Technical Configuration | 29 |
| 4.3.1 Solar PV Module..... | 29 |
| 4.3.2 Grid Tied Inverter | 30 |
| 4.3.3 Battery Inverter | 30 |
| 4.3.4 Battery Sizing..... | 31 |
| 4.3.5 Solar Charge Controller | 31 |
| 4.3.6 Support Structure for PV Module..... | 32 |
| 4.3.7 Conductor Selection..... | 32 |
| 4.3.8 Distribution Loss..... | 32 |
| 4.4 Safety and Protection | 33 |
| 4.5 Economic and financial analysis..... | 35 |
| 4.5.1 Bill of Quantities with Cost | 35 |
| 4.6 Bill of Quantities of Services | 37 |
| 4.7 Sensitivity Analysis | 39 |
| 4.7.1 Comparison with Diesel Generator Supply Option | 40 |

| | |
|--|-----------|
| 4.8 LCOE comparisons for various hybrid mini grids and mini grids..... | 41 |
| 4.9 Social Impact | 45 |
| 4.10 Environmental Impact..... | 45 |
| 4.10.1 Positive Impact..... | 46 |
| 4.10.2 Negative Impact..... | 46 |
| 4.11 Problems and Barriers faced by Solar Mini grid in Nepal..... | 47 |
| CHAPTER FIVE: CONCLUSIONS AND RECOMMENDATIONS | 49 |
| 5.1 Conclusions..... | 49 |
| 5.2 Recommendations..... | 50 |
| REFERENCES..... | 51 |
| ANNEXES..... | 58 |
| ANNEX-1: SURVEY QUESTIONNAIRE | 58 |
| ANNEX 2: LOAD PATTERN | 63 |
| ANNEX 3: VOLTAGE DROP CALCULATION..... | 68 |
| ANNEX 4: GPS LOCATIONS OF POLES AND POWERHOUSE..... | 70 |

LIST OF TABLES

| | |
|---|----|
| Table 2.1 Stand alone Solar PV systems and their Outcomes | 12 |
| Table 4.1 Information of Mikawakhola Rural Municipality | 22 |
| Table 4.2 Fuels used for Lighting | 23 |
| Table 4.3 Energy interventions | 24 |
| Table 4.4 Clearness index and global horizontal index | 26 |
| Table 4.5 Demand Projection | 28 |
| Table 4.6 Specifications of solar panel | 30 |
| Table 4.7 Specifications of grid tied inverter..... | 30 |
| Table 4.8 Battery Inverter | 31 |
| Table 4.9 Specifications of battery | 31 |
| Table 4.10 Specifications of support structure | 32 |
| Table 4.11 Bill of quantities of Power generation components..... | 35 |
| Table 4.12 Bill of quantities of Power transmission and distribution component..... | 36 |
| Table 4.13 Bill of quantities with services..... | 37 |
| Table 4.14 Cost estimate..... | 38 |
| Table 4.16 Sensitivity Analysis table..... | 39 |
| Table 4.17 Technical and Cost information of DG set | 40 |

LIST OF FIGURES

| | |
|--|----|
| Figure 2.1 Nepal Solar Radiation..... | 6 |
| Figure 3.1 Methodological flow chart..... | 17 |
| Figure 4.1 3D topographical map of Dalaicha village..... | 23 |
| Figure 4.2 Willingness to pay | 25 |
| Figure 4.3 Global horizontal irradiation | 25 |
| Figure 4.4 Daily Load Consumption | 27 |
| Figure 4.5 Daily load profile..... | 28 |
| Figure 4.6 Solar Mini Grid..... | 29 |
| Figure 4.7 Distribution diagram of Dalaicha village | 33 |
| Figure 4.8 LCOE for mini grids (2015–2035). IRENA (2016), | 42 |
| Figure 4.9 LCOE for variuos mini grids (2015–2035). IRENA (2016) | 43 |
| Figure 4.10 Different mini grid and hybrid mini grid’s LCOE (USD/kWh)..... | 44 |

LIST OF ABBREVIATIONS

| | |
|-------|---|
| AC | Alternating Current |
| AEPC | Alternative Energy Promotion Center |
| ACSR | Aluminum Conductor Steel Reinforced |
| CES | Center for Energy Studies |
| CF | Cash Flow |
| DC | Direct Current |
| DG | Diesel Generator |
| DFS | Detail Feasibility Study |
| EHS | Environment Health Safety |
| FIT | Feed-in Tariffs |
| GDP | Gross Domestic Product |
| GIZ | German Corporation for International Cooperation |
| GPS | Global Positioning System |
| GWh | Gigawatt-hour |
| GSR | Global Solar Radiation |
| HOMER | Hybrid Optimization Model for Electric Renewable |
| kWh | Kilowatt-hour |
| HHs | House Holds |
| IRENA | International Renewable Energy Agency |
| IRR | Internal Rate of Return |
| JICA | Japan International Cooperation Agency |
| KUKL | Kathmandu Upatuaka Khanepani Limited |
| kVA | Kilo Volt Ampere |
| kW | Kilo Watt |
| kWp | Peak Kilowatt |
| LCOE | Levelized Cost of Energy |
| MCB | Miniature Circuit Breaker |
| MG | Mini Grid |
| MGP | Mini Grid Partnership |
| MPPT | Maximum Power Point Tracking |
| MSREE | Master of Science in Renewable Energy Engineering |

| | |
|------|--------------------------------------|
| MW | Mega Watt |
| NEA | Nepal Electricity Authority |
| NGO | Non-Government Office |
| NPC | Net Present Cost |
| NPV | Net Present Value |
| NREL | National Renewable Energy Laboratory |
| LED | Light Emitting Diode |
| PV | Photovoltaic |
| RE | Renewable Energy |
| SPD | Surge Protection Devices |
| SPV | Solar Photovoltaic |
| SHS | Solar Home System |
| TV | Television |
| VAT | Value Added Tax |

CHAPTER ONE: INTRODUCTION

1.1 Background

Economic development and growth are greatly influenced by energy. Access to reliable and affordable electricity is crucial for socio-economic development, particularly in rural and remote areas. However, many remote regions around the world still lack access to grid-connected electricity, leading to limited economic opportunities and hindered progress. Solar energy is still the least used energy source in Nepal's economy, while being one of the safest, because of the rising demand for dependable and safe energy. In recent years, solar-powered Mini Grids have emerged as a promising solution to address this energy access challenge.

The Nepalese economy is primarily based on agriculture, providing a livelihood for 67% of the population and accounting for 33% of GDP. The country's energy consumption is strongly linked to GDP, but the manufacturing sector, currently at 58% capacity, operates below capacity. The government aims to raise Nepal to a middle-income country by 2030, transforming subsistence-based farming into large-scale commercial agriculture production and upgrading the industrial sector. India and China have already invested in Nepal through 898 and 629 energy projects, recognizing its potential energy sources. About 87% of households are connected to the national grid across the country according to Nepal Electricity Authority (NEA).

Even though Nepal has a huge potential for electricity generation from various renewable energy sources, approximately 4.5% of the population currently lacks access to electricity. The country's mountainous geography, with over 60% of the population living in hilly areas, makes electricity supply difficult. Isolated energy systems are suitable solutions, but face challenges like high costs, poor reliability, weak power quality, low load factor, poor maintenance, and inadequate institutional structure. Optimized hybrid energy systems offer cost, power quality, and reliability benefits for areas with complex and expensive national utility grid expansion. However, isolated energy systems face technical issues like low load factors, diversity factors, and reduced reliability. In Nepal, MHPs with less than 100 kW capacity do not provide profit due to only covering O&M costs, interest on loans, and salaries for operation and management. By introducing the idea of solar mini grid, these problems can be resolved.

Renewable energy-based mini-grid options have been identified as a better choice for providing electricity for remote households, where it will both be capital intensive and time intensive to get access to the national electric power grid.

The history of solar mini grids in Nepal began in 1984 with collaboration between the government and French Government (AEPC, 2022). In 2011, AEPC implemented a 12 kWp Solar-Wind hybrid mini grid project in Nawalparasi district (AEPC, 2022). The program has since been accelerated due to shorter project implementation cycles, solar resource availability, grid-quality electricity generation, and feasibility in various locations. AEPC promoted 30 off-grid solar and hybrid mini grids in Nepal, providing improved electricity access to rural households and higher wattage micro, small, and medium enterprises. These grids have a cumulative capacity of 1,262 kW (AEPC,2022).

Dalaicha Danda, a remote village situated in a hilly region, is a perfect example of an underserved community with limited or no access to electricity from the national grid. The absence of electricity in the village hampers daily activities, affects educational opportunities, and limits economic growth, resulting in significant barriers to development. The geographical location of Dalaicha Danda poses challenges for grid extension due to the rugged terrain and cost constraints.

In response to such energy access challenges, the concept of solar mini grids has gained momentum. Solar mini grids are decentralized energy systems that utilize solar photovoltaic (PV) technology, battery storage, and distribution networks to generate and distribute electricity locally. They offer a sustainable and environment-friendly solution, with the potential to transform remote communities like Dalaicha Danda into thriving and self-sufficient entities.

While solar mini grids present an attractive solution, their implementation requires careful consideration of technical and economic aspects to ensure their viability and sustainability. The techno-economic analysis of solar mini grids involves evaluating the technical feasibility, optimal design, and financial viability of such projects in specific locations. The outcome of this analysis guides policymakers, investors, and local communities in making informed decisions regarding the implementation of solar mini grids.

Previous studies have highlighted the success of solar mini grids in various contexts, but the viability of such a solution can vary significantly depending on the local conditions and energy demand patterns. Hence, conducting a case study specifically focused

on Dalaicha Danda will provide valuable insights into the potential benefits and challenges of implementing a solar mini grid in this unique setting.

This thesis aims to conduct a comprehensive techno-economic analysis of a solar mini grid in Dalaicha Danda. The study will assess the technical aspects of solar PV system design, battery storage, and distribution network, ensuring an optimal solution tailored to the village's energy demand. Moreover, the financial analysis will evaluate the economic feasibility of the proposed solar mini grid and its potential to provide sustainable electricity supply to the community.

This research aims to understand the socio-economic impacts of introducing a solar mini grid in Dalaicha Danda, focusing on improved living conditions, income generation, and environmental sustainability. It contributes to the body of knowledge on renewable energy solutions for rural electrification.

1.2 Statement of the Problem

Despite global efforts towards renewable energy adoption and rural electrification, many remote and off-grid communities still lack reliable access to electricity. Solar mini grids have emerged as a promising solution to address this energy access challenge, particularly in areas where grid extension is technically and financially impractical.

However, the successful implementation of a solar mini grid requires a thorough evaluation of its technical and economic aspects. The main problem this research seeks to tackle is the lack of comprehensive information and analyses specific to the proposed solar mini grid's context. This includes the technical design considerations such as sizing the solar PV system, battery storage capacity, and distribution network to meet the energy demand efficiently while considering the unique characteristics of the target area.

Additionally, there is a lack of in-depth financial analysis to determine the economic feasibility of the solar mini grid project. This includes assessing the total investment costs, operational expenses, potential revenue from electricity sales, and the financial viability of the project over its lifespan.

Moreover, the socio-economic and environmental impacts of implementing a solar mini grid need to be evaluated. It is essential to understand the potential benefits in terms of job creation, income generation, improved living conditions, and the contribution to local economic development. Furthermore, the study must analyze the environmental

benefits associated with using solar energy, including the reduction of greenhouse gas emissions and promoting sustainable energy practices.

Furthermore, identifying potential risks and challenges associated with the solar mini grid implementation is crucial. This includes factors such as technological limitations, regulatory hurdles, and uncertainties in financing and policy support that may affect the long-term sustainability and success of the project.

Addressing these research gaps will provide valuable insights and knowledge to guide policymakers, investors, and project developers in making informed decisions regarding the implementation of solar mini grids. By conducting a thorough techno-economic analysis, this research aims to contribute to the promotion of sustainable energy solutions, improve rural electrification efforts, and foster socio-economic development in remote and underserved areas. Ultimately, the problem statement of this thesis focuses on the need to evaluate the technical and economic feasibility of solar mini grids to ensure their successful implementation and impact on energy access and community development.

1.3 Objectives

1.3.1 Main objective

The main objective of this thesis is to evaluate the technical and economic feasibility of Solar Mini grid of Mikawakhola Rural Municipality-4, Dalaicha Danda, Taplejung.

1.3.2 Specific objectives

The specific objectives of the study are:

- To conduct a comprehensive technical analysis of solar Mini Grid
- To conduct a detailed financial analysis.
- To assess the potential socio-economic impacts of introducing solar mini grid.
- To evaluate the environmental benefits associated with the adoption of a solar Mini grid.

CHAPTER TWO: LITERATURE REVIEW

2.1 Solar Mini Grid Sector in Nepal

In many developing countries, a significant portion of the population still remains deprived of access to electricity. These underserved communities often reside in rural and remote areas, where the infrastructure for electricity distribution is limited or non-existent. The lack of electricity negatively impacts their daily lives, hindering economic opportunities, education, and healthcare services. The objective of most rural electrification programs in the developing world is to bring about socio-economic development to households (Azimoh et al., 2016). Previous reports have demonstrated a strong correlation between energy access and economic development (Peters et al., 2019). As a component of the ongoing global initiative to eradicate energy poverty, decentralized alternatives such as mini grids have gained recognition as an essential element in the endeavor to attain universal access to modern energy services by 2030 (Energy for all: financing access for the poor. Paris: International Energy Agency). Mini grids have been mentioned as a potential and workable option in recent debates over the electrification of the roughly one billion people in developing nations who still lack access to power (Peters et al., 2019). Solar mini grid projects are innovative and sustainable solutions that provide electricity to off-grid and underserved communities. The decentralized nature of mini grids ensures energy access in remote areas, spurring economic growth, improving education and healthcare services.

Nepal, a Himalayan country, predominantly comprises hills and mountains, making up 83% of its geography. Approximately 22% of the Nepalese population lacks access to electricity from the national power utility and around 4.5% of the population is still out of reach to electricity, necessitating the exploration of alternative electrification methods. The Micro/Mini grid (MG) system emerges as a promising solution in terms of its cost-effectiveness, reliability, and performance for rural electrification, particularly in areas where connection to the national power utility is not feasible from a technological and economic perspective (A. Shrestha et al., 2019). One of the main reasons behind this is the rugged topography of the country where extension of national grid comes in a hefty price. To compensate this, mini grids become a player to provide electricity. However, isolated energy systems face several challenges, including high costs, inadequate reliability, weak power quality, low load factor, insufficient maintenance, a fragile institutional structure, and a lack of proper monitoring and supervision. These factors

pose significant obstacles to the effective functioning of such energy systems in remote and off-grid locations (Bhandari et al., 2014), (B. Shakya et al., 2019). Nevertheless, the majority of rural areas in Nepal face challenges with sparse population, isolation, and limited accessibility. These poor rural regions exhibit low access rates and low load factors in their electricity market (Mainali, 2011). By harnessing the abundant solar energy available in these regions, mini grids offer a reliable and affordable source of electricity for residential, commercial, and agricultural applications.

Nepal's geographical location lies between latitude $26^{\circ}22'$ – $30^{\circ}27'$ and longitude $80^{\circ}4'$ – $88^{\circ}12'$. The area has around 300 sunny days per year with an estimated average Global Solar Radiation (GSR) of 3.6 to 6.2 kW h/m²/day. The average daily solar intensity in the country is 4.7 kW h, with 6.8 hours of bright sunlight each day. These favorable solar conditions present significant potential for harnessing solar energy as a sustainable power source in the country (Energy Sector Synopsis Report Nepal, 2010). Solar Mini Grid projects offer a reliable and sustainable solution for rural electrification, especially in regions where grid connections are not economically feasible. By strategically implementing Solar Mini Grid projects, Nepal can harness its abundant solar resource to generate clean and affordable electricity locally.

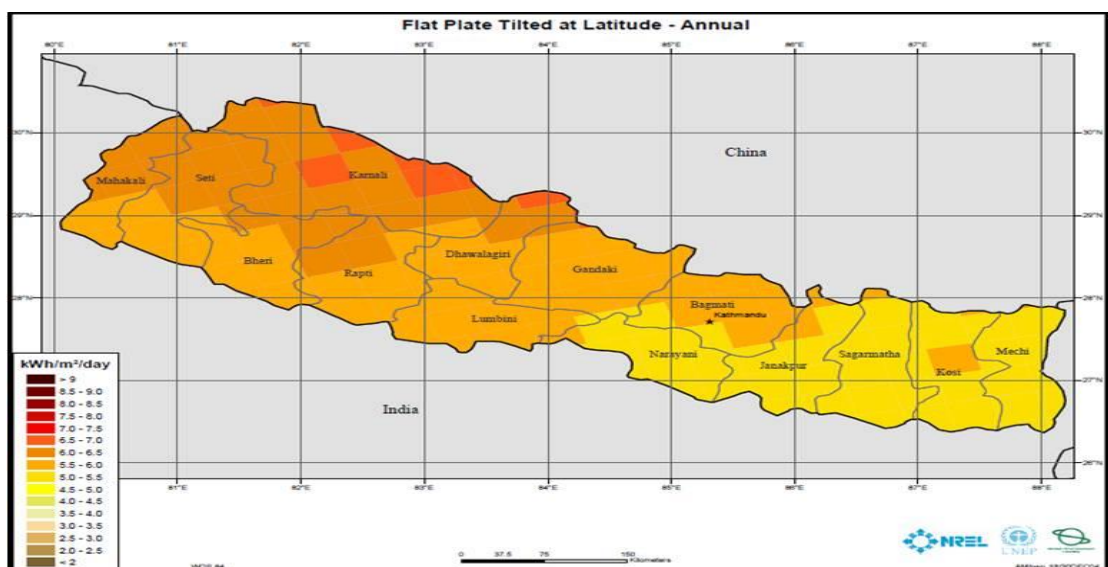

Figure 2.1 Nepal Solar Radiation (source NREL)

A grid-connected solar system is just beginning to emerge in Nepal. The 1 MW design at Singha Durbar, the 680 kW system at Sundharighat, the 100 kW system at Kharipati,

the 65 kW system at Nepal Telecom, and the 1 KW test project at the Institute of Engineering, Pulchowk Campus, mark the beginning of solar power history. But on a commercial basis, the PV system hasn't yet gained traction (Bajracharya, 2019). A 7-MW Grid-connected PV system was just added to Nepal's national grid. In a similar vein, other projects include the installation of solar power at Bhairahawa Airport, one of Nepal's provincial airports. the expected cost of establishing the PV system at the aforementioned airport was \$10 million, or \$1 million for every megawatt (Kathmandu Post,2020). The GoN started developing the necessary regulations for feed-in tariffs (FIT) and net metering (with NRs 7.30 per unit) in 2018, but the delay in their widespread adoption is due to their reluctance to be put into effect (NEA, 2019). There are only a handful solar power plants that are connected to the grid and are being compensated using the net metering concept as shown below.

- 680 kW solar at Kathmandu Upatyaka Khanepani Limited (KUKL). (JICA, 2010)
- 65 kW solar at Nepal Telecom in Sundhara. (S.M. Bajracharya & S. Maharjan, 2019)
- 60 KW solar at Bir hospital in Kathmandu. (NEA, 2011)
- 960kW Bishnu Priya Solar Farm Project in Nawalparasi. (NEA, 2020)
- 8500kW Butwal Solar Project at Rupandehi. (NEA, 2020)
- 10000 kW Mithila Solar PV Electric Project in Dhanush. (NEA,2020)

These projects involve the installation of small-scale solar power systems that can generate and store energy locally, reducing dependency on traditional fossil fuels and centralized grids. In many poor nations throughout the world, solar energy has grown significantly in favor as an off-grid electrification alternative, with different degrees of effectiveness. In South Asia, in particular, it has demonstrated to be an effective and promising option. (Palit & Chaurey, 2011).

In the array of electrification solutions available for off-grid locations, notable options include solar home systems (SHS), pico-grids, mini grids, standalone non-household systems, grid-connected mini grids, and grid extensions. Among these, mini grids stand out as cost-effective, high-quality distributed electrification solutions, featuring various ownership models and flexible, modular sizing(Pedersen, 2016).Mini grids, are small,

isolated systems for distributing electricity that can be used to provide power to communities or institutions that are not connected to the utility grid. GIZ, 2016;(The Mini grids Partnership (MGP), 2020; (Magni et al., 2022); Kumar et al., 2019).

A mini grid can generate electricity from a single energy source or from multiple sources. Hybrid mini grids are those that generate electricity from multiple sources simultaneously. Some instances of hybrid mini grids are PV/biomass mini grids, PV/wind mini grids, and PV/biomass mini grids.

In addition, mini grids can be grid-tied (Samy et al., 2021), standalone (The Mini grids Partnership MGP, 2020; Wu et al., 2021), or connected to the grid. Mini grids can be categorized as interconnected or autonomous. Autonomous mini grids are independent of other grids and are subdivided into lower-tier levels and higher tier levels. The lower tier of the service grid is in Tier 3–4 and supplies power for less than 24 hours and is used to support basic loads. Tier 5 is a higher tier service that provides round-the-clock power. A mini grid that can connect to nearby grids is called an interconnected mini grid. They are separated into two categories: tier 5++ interconnected major industrial applications and tier 5+ interconnected community applications. (IRENA, 2016).

In response to this prospect, numerous non-governmental organizations (NGO) have installed solar electric systems for a variety of community development projects in collaboration with the NEA. These projects included the installation of three large centralized village-scale PV stations in Simikot in Humla, Gamgadi in Mugu, and Tatopani in Sindhupalchowk, each with a capacity of 30 to 50 kW (CADEC, 2004). Poor component design, a "overly elaborate and expensive centralized design, and a lack of proper maintenance support" all contributed to the poor performance of these systems. Traditionally, solar energy has been used to dry crops, textiles, fuelwood, crop leftovers, and other items. With the advancements in technology, it is now employed in tourist and metropolitan areas for water heating purposes. Solar photovoltaic (PV) usage has greatly increased since the Government of Nepal (GoN) started offering subsidies. The number of solar PV systems installed has increased significantly because to the participation of various companies in this industry, from 0.3 kWp in 1992 to 3328.42 kWp in 2005.

2.2 Technical Aspects of Solar PV Systems

Solar PV systems consist of several essential components, which encompass solar panels, charge regulators, batteries, inverters, and protective devices. These elements work in synergy to enable the efficient conversion and utilization of solar energy into electricity. Technological advancements and innovations have significantly improved the efficiency, reliability, and overall performance of solar mini grid projects, making them increasingly viable and attractive for rural electrification. Innovations in PV module, battery storage, remote monitoring and control, hybrid mini grids, etc. are transforming the landscape of rural electrification, empowering underserved communities with clean, affordable, and sustainable electricity access. The integration of solar mini grids with other renewable energy sources like wind, hydro, or biomass has resulted in hybrid mini grids. These systems provide a more stable and reliable power supply by diversifying energy sources, especially in areas with intermittent solar availability (Awasthi et al., 2020).

Solar PV systems are categorized into three types: grid-tie systems, standalone systems, and hybrid systems. Grid-tie systems are linked to the main grid and cease operation when the grid experiences an outage. Standalone systems, on the other hand, operate independently without any connection to the grid, equipped with batteries to serve as backup during periods of insufficient sunlight (Awasthi et al., 2020). Lastly, hybrid systems integrate two or more power sources to ensure a continuous supply of electricity. Solar PV (SPV) based energy generation is increasingly emerging as the most cost-effective option for power production in multiple regions worldwide, with expectations of substantial investments in the years ahead (Mahela & Shaik, 2017).

There are certain standard procedures required to design the solar mini grid, which include the analysis and evaluation of the load capacity requirements for the solar mini grid from the primary survey in the location, battery design, and electrical components. To calculate the number of solar arrays (N) and the capacity of the battery bank (B) required in a solar mini grid project, we could use the following formulas (Saulo, 2015):

2.3 Socio-Economic aspect of solar mini grid

The technical and economic feasibility of the solar mini grid project comes from the social-economic potential for the village, their current energy use, and their willingness to be connected and to pay (Maliro et al., 2022). Similarly, the success and long-term use of the project is also dependent on various factors such as (A. Shrestha et al., 2019):

- Technical issues: In all cases, the mini grids (MGs) are situated in rural regions where accessing skilled human resources and appropriate equipment may be challenging at the required time resulting in lack of proper maintenance (Alternate Energy Promotion Centre (AEPC), 2018)
- Political changes: The lack of human resources and capacity in municipalities, coupled with ambiguous roles and responsibilities among governmental agencies at different levels of governance (municipalities, provinces, and federal), has significantly impacted the implementation of MG projects (A. Shrestha et al., 2019).
- Operational issues and payment risk: Conflicts between human resources, management, and consumers can hinder the efficient attainment of desired outcomes within the entire system (A.K. Shakya & Shrestha, 2015).
- Low productive use: Micro-grids are mainly used for basic electrical needs such as lighting, TV and mobile charging. This type of utilization does not generate enough revenue for a project to become profitable (AEPC, 2018).

In the study done by (Azimoh et al., 2016) at two locations in South Africa, the assessment of technical and economic feasibility for optimized hybrid mini grids demonstrates that mini grids offer a more favorable solution than standalone solar home systems (SHS) for fulfilling the energy requirements of rural communities. They also found that the optimized mini grid systems have sufficient electricity generation capacity to support development activities, such as agriculture, businesses, and public services, in rural communities, given that the power is utilized judiciously.

Through a comprehensive life-cycle cost analysis, it is evident that solar PV-based mini grids with storage are more cost-effective than traditional energy services offered to households lacking central grid connection such as Micro Hydro and Diesel Generator (Comello et al., 2017). Mini grid projects are unable to operate sustainably due to regulatory challenges, low rural electricity demand, high rates of payment, and excessively optimistic demand forecasts. Adopting business strategies that take into account rural transaction costs and precise demand estimates for rural regions would increase the financial feasibility of omni grid. (Peters et al., 2019).

2.4 Solar mini grid system researched Direction.

Several research and case study has been done in solar mini grid till now in Nepal and internationally as well. Some of the research done in Nepal and internationally has been discussed below:

Bhattarai (2013) evaluated the performance study of a one kW grid-connected solar PV system at Tribhuvan University's Institute of Engineering's Center for Energy Studies (CES), gathering real-world data. He observed that the array's production was 2.64 kWh/day, the system's average final yield was 2.31 kWh/day, and the performance ratio was 0.488 during typical loadshedding. Additionally, his investigation determined that the cost of power per unit was NRs. 16.63.

In a study by Tiwari et al. (2017) titled Performance Analysis of 100 kWp Grid Connected Solar PV System, A Case Study at Kharipati, Bhaktapur, Nepal, the author discovered that the system's total measured annual energy output was 88.40 MWh, with maximum energy production occurring in November (10.53 MWh) and minimum energy production occurring in January (4.39 MWh). The average final yield for the year 2016 was 2.42 kWh/Wp/day. This study also found that one of the barriers to adding electricity to the grid and lowering system performance was the network's unavailability.

In a case study on grid-integrated solar power for the National Dasratha Stadium, (A.K. Shakya & Shrestha, 2015) found that the levelized cost of electricity (LCOE) for a utility-scale hybrid grid-tied solar PV plant would be NRs.18/kWh for a 20-year period and NRs.12.5/kWh for a purely grid-tied solar PV plant. This study found that by exploiting the advantages of a grid-tied solar PV plant, Nepal's lone national stadium could eliminate the need for diesel generators, reduce daytime utility electricity costs, and operate sustainably.

According to Shrestha and Shrestha J.N. (2014) study, "Techno-Economic Analysis of Utility Scale PV Plant: A Case Study on the 1 MWp Plant at Trishuli," the plant's system yield and capacity utilization factor would be 4.81 kWh/kWp/day, 20.18%, and 0.773, respectively. Additionally, he concluded that the cost of the plant's power would be NRs. 10.5/kWh. His ultimate finding was that utility-scale grid-tied solar PV plants are technically and financially feasible for bridging Nepal's energy gap.

V. Sharma and Chandel (2013) carried out a performance analysis on a 190 kWp grid-connected solar photovoltaic power plant in Khatkar-Kalan, India. The outcome gave

insight into the solar power plant's long-term performance under its actual operational circumstances in India. The system under study had a system efficiency of 8.3%, a capacity factor of 9.27%, and a performance ratio of 0.74.

The performance of an 11.2 kWp grid-connected rooftop PV system in Eastern India, which was observed from September 2014 to August 2015, was presented by R. Sharma and Goel (2017). According to this study, the system's performance ratio was 0.78, and the total amount of energy produced throughout the study period was 14.96 MWh.

Ayompe et al. (2011) conducted research on the measured performance of a grid-connected 1.72 kW rooftop photovoltaic system in Ireland and discovered that the system's final yield and reference yield were 2.41 kWh/kW/day and 2.85 kWh/kW/day, respectively. This analysis also found that the system's performance ratio and capacity utilization factors were, respectively, 0.815 and 10.1%.

Some of the stand alone Solar PV systems and their outcomes are shown in Table 2.1

Table 2.1 Stand alone Solar PV systems and their Results

| Study/Project Site | Load type | Design Capacity | Results |
|---------------------------------------|--|---|---|
| Kerman, Iran (Ameri and Askari, 2011) | An annual load of 24.4 MWh per year for 50 typical rural households. | 19KW solar-PV, 12 components (2V, 3000Ah) Battery | <p>i) The solar PV/battery system was chosen for this location due to its low maintenance requirements, low cost, and strong solar radiation availability.</p> <p>ii) The LCOE of the solar-PV/bat system is \$0.247/kWh, the wind-bat system is \$0.379/kWh, and the hybrid solar-PV/wind/bat system is \$0.243/kWh in the absence of a shortage of electricity.</p> |

| Study/Project Site | Load type | Design Capacity | Results |
|---|---|---|--|
| | | | iii) Solar-PV/bat systems have a total net present cost of \$120 738, while wind/bat systems have a total NPC of \$185 375 and a hybrid NPC of \$118 965. |
| Rural area, India. (Kamalpur and Udaykumar, 2010) | 3 lights, 1 television, and 1 radio comprise the 219 kWh/yr load. | solar-PV of 150W, 60 Ah battery | <p>i) Compared to a diesel generator system or grid extension, the solar-PV system was shown to be more cost-effective.</p> <p>ii) Compared to a diesel generator system or grid extension, the solar-PV system was shown to be more cost-effective. After 8.64 kilometers, the solar-PV system became commercially feasible without any assistance.</p> <p>iii) Without subsidies, the LCOE of a solar-PV system is \$0.258/kWh, while the LCOE of a grid-connected system is \$0.12/kWh.</p> |
| Rural areas, southern Iraq. (Al-Karaghoul) | an 11,534 kWh/yr load for a medical facility. | 80 pcs of 6 V, 225 Ah, 6 kW solar panels with a battery | i) The intended solar-PV system was found to be more cost-effective than a DG-only system. |

| Study/Project Site | Load type | Design Capacity | Results |
|---|--|---|--|
| and Kazmerski, 2010) | | | <p>ii) CO₂ and other dangerous gas emissions are reduced by 14,927 kg annually by the solar-PV system.</p> <p>iii) The solar-PV system's LCOE and NPC are \$0.238/kWh and \$60,375, respectively, compared to the diesel-only system's LCOE and NPC of \$1.332/kWh and \$352,303.</p> |
| Tunisia, located in North Africa. (Mnassri and Leger, 2010) | Small remote communities, 24h load approximately 83,161.6kWh/yr. | 41.6 kW (260 pieces at 160W) solar-PV, 228 kWh battery bank | <p>i. The solar-PV system is less expensive than the on-site DG system.</p> <p>ii. For the standalone solar-PV system LCOE and total cost over a 30-year period are \$0.240 per kWh and \$542,618 while for the DG-alone system, its \$0.289 per kWh and \$651,822.</p> |
| Tripos Kythnos. (Tselepis, 2003) | The load of a farmhouse, approximately 4.2kW | 2160W solar-PV, 30pieces with a lead-acid battery | i) The solar-PV system is more affordable than grid extension to this project's site, which is 1000 meters from the grid generation station. |

| Study/Project Site | Load type | Design Capacity | Results |
|--|--|---|---|
| | | (50 kWh nominal capacity) | ii) Total investment costs, including 18% VAT, for the solar-PV system were \$31,837.86 and \$54,465.01 for the grid extension. |
| Tocantins, Brazil. (Silva et al., 2013) | the annual load on an average rural home is 8.7 MWh. | 16. pieces of 12. V 220 Ah lead acid solar panels with a battery, 6.28 kW | i) Compared to the solar-PV/fuel cell system, the solar-PV/battery system was more cost-effective ii) The solar-PV system's LCOE and NPC are \$0.657/kWh and \$497, respectively, whereas the solar-PV/fuel cell system's are \$1.351/kWh and \$102,323. |
| Rural area, Bangladesh. (Khan et al., 2012) | 2 fluorescent bulbs and 2 LED lamps need to be run for 3 hours at night. | 12 V, 30 Ah battery, 25 W solar-PV | i) SHS is more economical and environmentally beneficial than the oil light system. ii) Over a 20-year period, the SHS system would cut CO ₂ emissions by 4.82 tons iii) The SHS has an annual total energy cost of \$37.825 whereas the oil lamp system has an annual total energy cost of \$64.1 at \$0.64 per liter of oil. |

| Study/Project Site | Load type | Design Capacity | Results |
|---|---|-------------------------------------|---|
| Village in the north-east of Thailand, (Rapapate and Gol, 2007) | A rural home's load consists of 3 lights, 1 fan, 1 radio, and 1 TV, totaling 197.83 kWh per year. | 220W solar-PV, 250 Ah BD125 battery | <p>i) It was determined that the solar-PV system is more economical than radial propagation for this low load application at a remote location.</p> <p>ii) A 5 kilometer grid link has an LCOE of \$26.80/kWh, but a standalone solar PV system has one of \$1.233/kWh.</p> <p>iii) The stand-alone solar PV system's total lifecycle cost during its expected 20-year lifespan is \$4886.26 and the cost of a 5-kilometer grid connection is \$106,070.5</p> |

Based on exchange rates, the currency was changed in December 2012.

a. US\$1= 54.62 Rupee (Indian).

b. US\$1= 30.64 Baht (Thai).

c. 1 Euro= US\$1.3102.

CHAPTER THREE: RESEARCH METHODOLOGY

This chapter aims to provide an overview of the methods that were adopted in order to gather relevant information to analyze the situation and to achieve the fore-stated objectives. The case study outlines the literature review, development of detail methodology, questionnaire development, site survey, technical analysis, financial and social analysis as shown the flow chart figure 3-1.

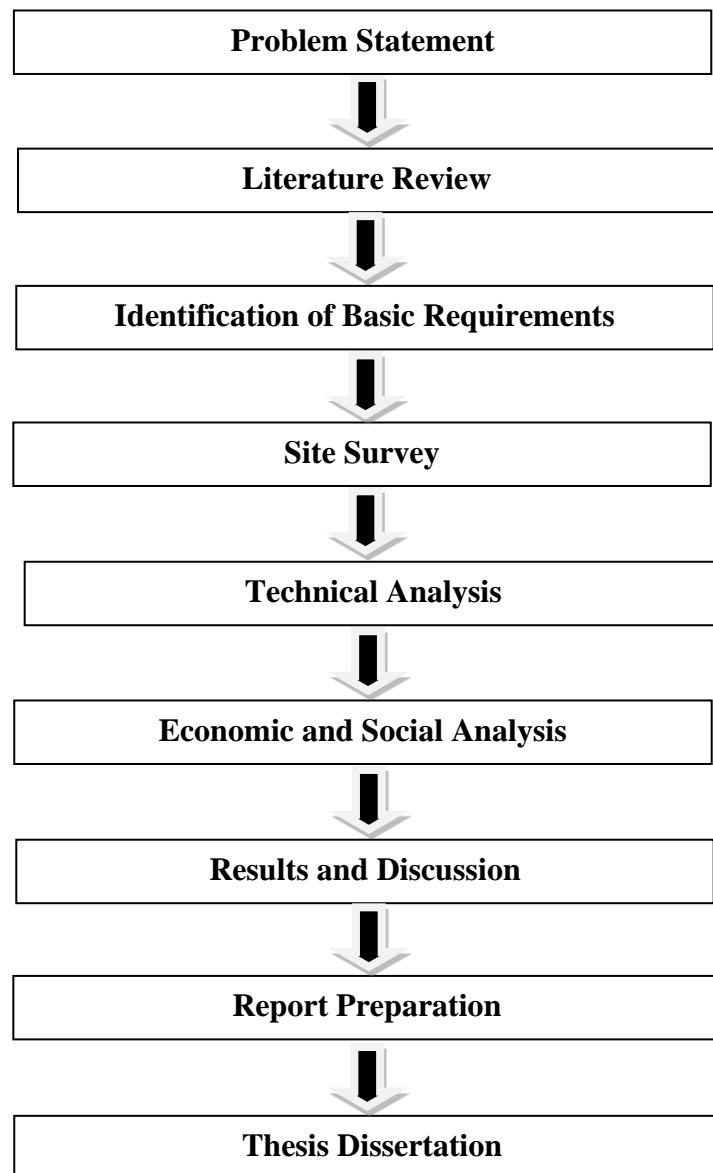

Figure 3.1: Methodological flow chart

3.1 Literature review

The primary goal of this phase is to study pertinent plans and regulations pertaining to the promotion, development, and installation of solar mini grid. The client and other stakeholders' various data and information relating to the assignment have been gathered and reviewed. A comprehensive analysis of the solar mini grid system was conducted, and a variety of technical information on the mini grid was gathered and examined. The literature review begins by identifying key research areas and topics relevant to the thesis. This involves searching academic databases, journals, conference proceedings, and reports related to solar mini grids, renewable energy, rural electrification, and related subjects. Only articles and publications that directly contribute to the understanding of the techno-economic aspects of solar mini grids and rural electrification are included.

3.2 Site Survey

The main aim of this phase of work was to identify the location where NEA electrification hasn't reached and there is need of alternate electrification. The research location for this research is taken as Mikuwakhola rural municipality ward no 04 (Dalaicha Danda) Taplejung District. Field visit to the site location was done to collect data through surveys, questionnaire, interviews, or other data collection methods to assess the availability and quality of data related to the research topic.

3.3 Technical Analysis of solar Mini Grid

After detailed Site Survey, technical analysis for the solar mini grid was conducted. Data like solar irradiance and weather patterns in the area, electricity demand of the target community, were studied to ensure that the solar mini grid's energy generation capacity matches the community's energy needs. The solar PV system's battery storage capacity, inverter and controller selection, and sizing were carried out using data on solar irradiance and energy demand assessment. The distribution system was similarly created so that the voltage drop in AC distribution is less than 10% and the voltage drop in DC distribution is less than 1%.

3.3.1 Number of Solar Arrays (N)

$$N = \text{Load} / \text{SolarPanelCapacity} \times \text{SolarHoursperDay} \times \text{SystemEfficiency}$$

Where,

- N is the number of solar arrays (or solar panels) needed.

- Load is the total electricity demand or load of the location in watt-hours (Wh) or kilowatt-hours (kWh).
- Solar Panel Capacity is the capacity of each solar panel in watt-peak (Wp) or kilowatt-peak (kWp).
- Solar Hours per Day represents the average number of hours of peak sunlight available in the location. It can be determined using solar irradiance data specific to the location or the average daily sunlight hours.
- System Efficiency is the overall efficiency of the solar mini grid system, which takes into account losses in various components, such as solar panels, charge controllers, inverters, and batteries.

3.3.2 Capacity of Battery Bank (B)

$$B = \text{Load} \times \text{AutonomyDays} \div \text{BatteryEfficiency} \times \text{Inverter Efficiency} \times \text{Depthof Discharge}$$

Where,

- B is the capacity of the battery bank needed in ampere-hours (Ah) or kilowatt-hours (kWh).
- Load is the total electricity demand or load of the location in watt-hours (Wh) or kilowatt-hours (kWh).
- Autonomy Days is the number of days the mini grid should be able to operate without receiving solar energy (typically during cloudy or low-sunlight periods).
- Battery Efficiency is the efficiency of the battery in storing and releasing energy.
- Inverter Efficiency is the efficiency of the inverter in converting DC power from the battery to AC power for use.

3.3.3 DoD (Depth of Discharge)

It is the percentage of the battery's total capacity that can be used before recharging. The complete energy held in many different types of batteries cannot be extracted (or, put another way, the battery cannot be totally discharged) without inflicting the battery considerable, and frequently permanent, harm. The amount of power that may be extracted from a battery depends on its Depth of Discharge (DOD). For instance, if a battery's DOD is listed as 25% by the manufacturer, the load can only use 25% of the battery's capacity.

3.4 Economic Analysis of solar Mini Grid

Along with installation and maintenance, the financial elements of various system characteristics were taken into account for various economic and financial analysis including simple payback period, IRR, etc.

3.4.1 Simple payback period

The simple payback period is a basic financial metric used to evaluate the time it takes for an investment or project to generate enough cash flows to recover the initial investment cost. It's a quick and straightforward way to assess the risk and return of an investment. The formula for calculating the simple payback period is:

Simple Payback Period = Initial Investment / Annual Cash Flow

Where:

- Initial Investment: The upfront cost of the investment or project.
- Annual Cash Flow: The net cash flow generated by the investment or project each year. This is usually the positive difference between the cash inflows and outflows.

The result of the calculation will be the number of years it takes for the project to recoup its initial investment. However, the simple payback period does not take into account the time value of money, which means it doesn't consider the fact that money received in the future is worth less than money received today due to inflation and the potential for investment returns.

While the simple payback period is easy to calculate and understand, it has limitations. It doesn't provide a comprehensive picture of the investment's profitability and doesn't consider cash flows beyond the payback period. As a result, more sophisticated methods like the net present value (NPV) and internal rate of return (IRR) are often used for more accurate investment analysis.

3.4.2 Net Present Value (NPV)

Net Present Value (NPV) is a financial metric used to evaluate the profitability of an investment or project by considering the time value of money. It takes into account the concept that money received or spent in the future is worth less than money received or spent today due to factors like inflation and the opportunity cost of not investing that money elsewhere.

The formula for calculating NPV is as follows:

$$NPV = \sum [CF / (1 + r)^t]$$

Where:

- CF = Cash flow in a specific period (could be positive or negative).
- r = Discount rate, which represents the required rate of return or the opportunity cost of capital.
- t = Time period (year, month, etc.).

The NPV calculation involves summing up the present values of all cash flows (both inflows and outflows) over the life of the investment or project. If the NPV is positive, it indicates that the investment is expected to generate more value than its initial cost and could be considered a potentially profitable opportunity. Conversely, if the NPV is negative, it suggests that the investment may not be financially viable.

3.4.3 Internal Rate of Return (IRR)

The Internal Rate of Return (IRR) is another important financial metric used to evaluate the potential profitability of an investment or project. It's a discount rate that makes the net present value (NPV) of future cash flows from the investment equal to zero. In other words, the IRR is the rate at which the present value of future cash inflows equals the present value of the initial investment, resulting in a net value of zero.

Mathematically, the IRR is determined by solving the equation:

$$0 = \sum [CF / (1 + IRR)^t]$$

Where:

- CF = Cash flow in a specific period (could be positive or negative).
- IRR = Internal Rate of Return, the rate being solved for.
- t = Time period (year, month, etc.).

The IRR represents the yield an investor can expect to earn from the investment based on its cash flows and timing. If the calculated IRR is greater than the required rate of return (often referred to as the cost of capital), then the investment is potentially worthwhile. If the IRR is lower than the cost of capital, the investment may not be attractive.

CHAPTER FOUR: RESULTS AND DISCUSSION

A socio-economic survey and demand survey based on the questionnaire prepared was done to understand the energy demand along with financial condition and willing to pay of the residents of the village of Mikawakhola Rural Municipality, Ward no 4, Taplegunj. A site was selected to install the solar PV panel along with construction of the power house. Thus, selected site was such that it has sufficient space along with minimum chances of partial shading. To determine the distribution system of the Mikawakhola Rural Municipality, the GPS coordinate along different paths and road were taken in such a way that the overall conductor length is minimum. Following are the results from the survey and the technical analysis as well as financial analysis conducted.

4.1 Locations

The research location for this research is taken as Mikawakhola rural municipality ward no 04 (Dalaicha Danda) Taplejung District It located around 850 km North East of Kathmandu. Mikawakhola village municipality is one of the local level formed on 2073/11/27 under the province. Mikawakhola is an area of great potential in terms of cardamom cultivation, mountaineering, sightseeing and herbal collection. The latitude and longitude of Mikawakhola Rural Municipality is 27.38° north and 87.501°E and covers a total land area of 143.75 sq. km. According to 2075 B.S. household survey, the overall population of Mikawakhola Rural Municipality is 10120 (female-4971, male-5149) and the number of households is 1742. The details of Mikawakhola Rural Municipality are shown in Table 4.1.

Table 4.1 Information of Mikawakhola Rural Municipality

| | |
|------------------------|---|
| Latitude, Longitude | 27.38 ^o ,87.501 ^o |
| Literacy rate | 85% |
| Average household size | 5.8 |
| Population density | 4.1 per sq. km. |
| Household per sq. km | 35.74 |
| Major cast | Limbu(46%) Shrepa(27.5%) Chhetri (12.8%), Tamang(1.7%), Rai(10.67%) |
| Major occupation | Agriculture (49%), Mason,(22%) |

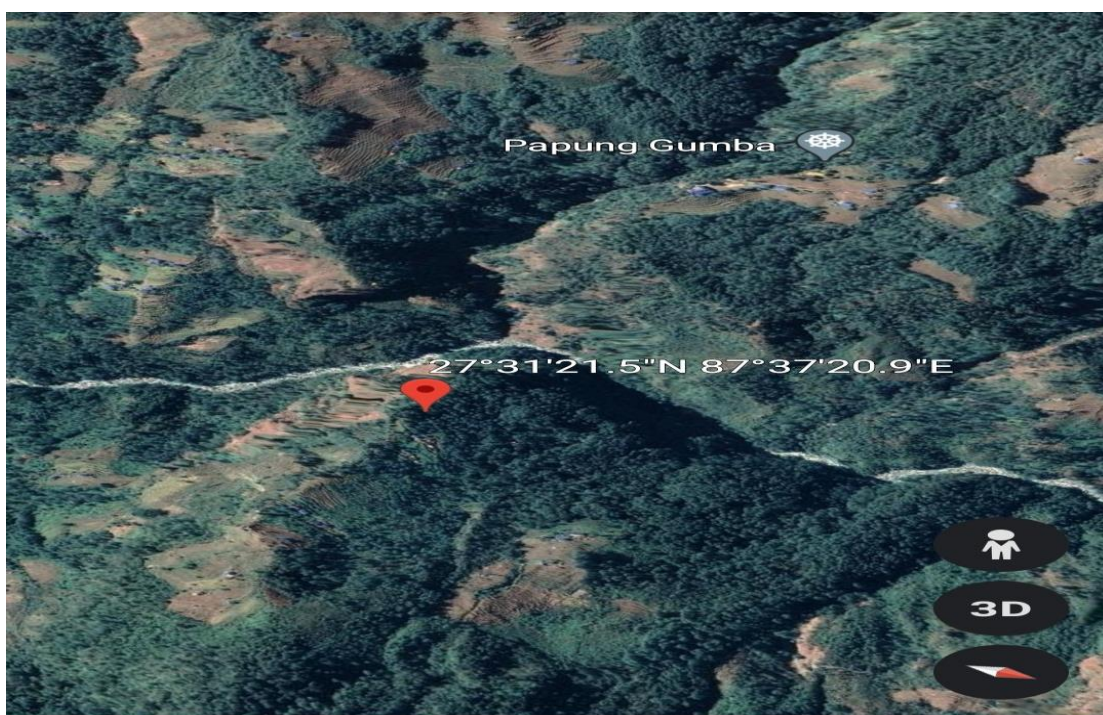

Figure 4.1 3D topographical map of Dalaicha village

According to the Household Survey 2078 B.S., not yet any connection to national grid in Mikawakhola Rural Municipality. While the other 54.64% of the household are dependent on micro hydro and 44.14% solar home system for lighting purposes there are still more than 4.44% of the population i.e., dependent on kerosene and other fuels for electrification.

Table 4.2 Fuels used for Lighting

| | |
|-------------------|--------|
| Solar home system | 44.14% |
| Micro hydro | 54.64% |
| Kerosene | 1% |
| Others | 4.44% |

4.2 Energy Survey Output of Dalaicha Danda

Socio-economic survey and demand survey based on the questionnaire prepared was carried out in Dalaicha Danda. During the survey, various village representatives and citizens were questioned to learn about the residents' financial situation, willingness to pay, and energy demand.

Similarly, a location was chosen for the power house construction and installation of the solar PV panel. As a result, the site was chosen because it offers ample space and a low likelihood of partial shadowing. In order to determine the Mikuwakhola Rural Municipality's distribution system, GPS coordinates were taken along various pathways and roads so that the overall conductor length was kept to a minimum.

4.2.1 Energy Interventions

The main source of energy in Dalaicha Danda village is wood. People use fuel wood for cooking and heating. Out of the 60 houses in the Dalaicha Danda village of Mikuwakhola Rural Municipality, 75% of the household use SHS for lighting, 2% uses kerosene for lighting and the rest 23% are dependent on diesel. Most of the SHS are of 35Wp while some of them are found to be of 100Wp and 150Wp panel. Villagers reported that on average 25-30kg of wood per day per household for cooking and other purposes. The monthly cost for wood is around NRs. 4,500 per month.

Table 4.3 Energy interventions

| | |
|--------------------------------------|---|
| Present source of lighting | Solar Home system (75%), Kerosene (2%), Diesel (1%) |
| Quantity of fire wood (average)/day | 25-30kg |
| Average monthly cost of cooking fuel | NRs. 4,500 |

During the field visit, most of the residents desired solar mini grid for domestic purposes generally for lighting and entertainment purposes.

4.2.2 Willingness to Pay

The survey reveals that ward office of Mikawakhola Rural Municipality is willing to pay around 10% of the total cost of the installation. The domestic and institutions consumers in Dalaicha Danda village are willing to pay around Rs.8/kWh and while the anchors /business are willing to pay around NRs.15/kWh for. The average monthly cost that the residents are willing to pay is presented in the Figure 4.2. The users that are willing to pay above NRs. 500 are the high-end users (at least one member involved in foreign employment), institutions (School, health post) and business entrepreneur.

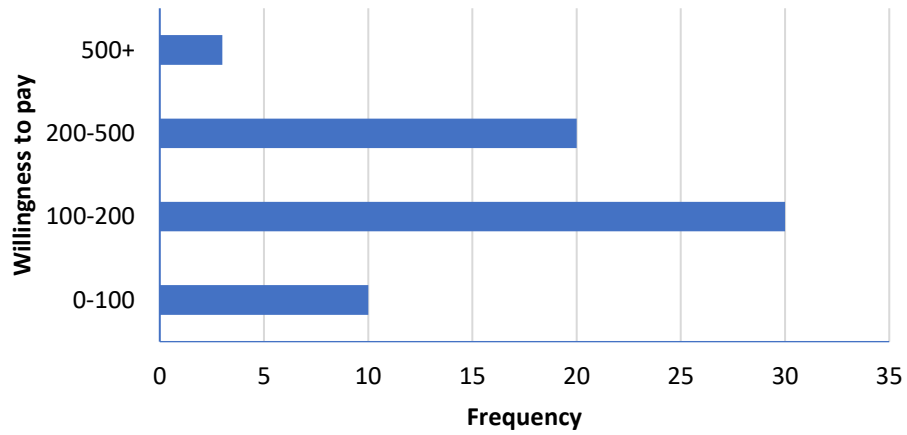

Figure 4.2 Willingness to pay

4.2.3 Energy Resource Assessment

Dalaicha Danda village of Mikawakhola Rural Municipality is well suited for solar PV installation. The site is surrounded by hills. The average solar isolation of the site is $5.16\text{kWh}/\text{m}^2/\text{day}$ which is adequate for solar PV installation. The average total sunshine hour is taken as 5 hours. The chart below shows the Global horizontal irradiation of the site across the year. The data has extracted from Metronome 7.3 (1991-2010), Sat=100%.

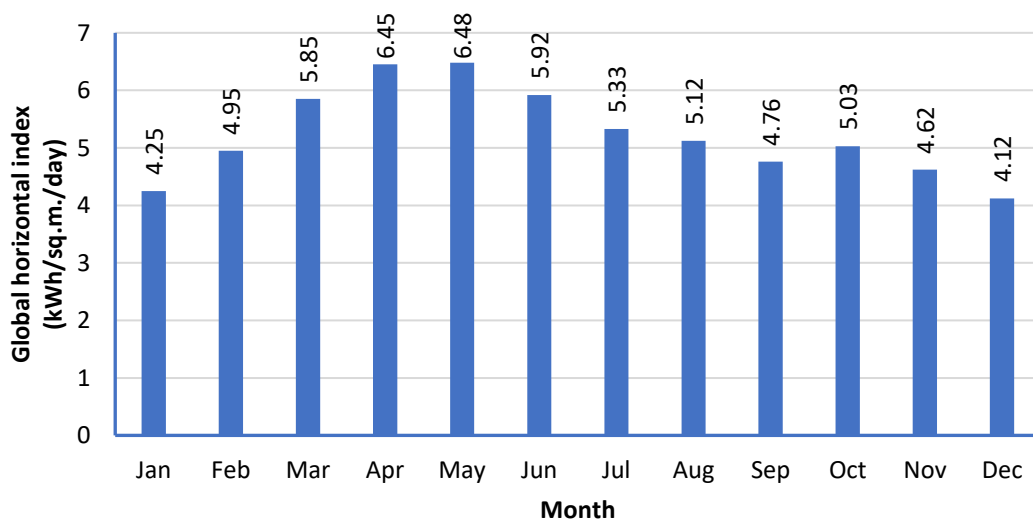

Figure 4.3 Global horizontal irradiation (source Metronome 7.3)

The clearness index is a measure of the clearness of the atmosphere and gives the solar radiation that is transmitted through the atmosphere to strike the surface of earth. The clearness index and global horizontal index of the Dalaicha Danda village is shown in Table 4.4.

Table 4.4 Clearness index and global horizontal index

| Month | Clearness index | Global horizontal index (kWh/m ² ./day) |
|-----------|-----------------|---|
| January | 0.67 | 4.59 |
| February | 0.60 | 5.13 |
| March | 0.52 | 5.6 |
| April | 0.51 | 6.37 |
| May | 0.51 | 6.1 |
| June | 0.52 | 5.71 |
| July | 0.47 | 5.22 |
| August | 0.47 | 5.12 |
| September | 0.45 | 4.59 |
| October | 0.53 | 4.65 |
| November | 0.62 | 4.63 |
| December | 0.74 | 4.45 |
| Total | 0.54 | 5.16 |

4.2.4 Energy demand and Projection Analysis

The total electrical demand for the base year 2021 was collected by a primary survey conducted in the concerned locality. The total demand for the base year 2021 is calculated to be 62.4kWh/day. The peak load is calculated to be 6.5kW. Most of the households will use the energy from solar mini grid for lighting, radio, mobile charging and television while the few household are also interested in using laptops, electric kettle and heater. Also, as there are two business i.e., rice mill and wood mill, where there is electricity demand for induction motor. The daily load consumption of Dalaicha Danda village is shown in Figure 4.4

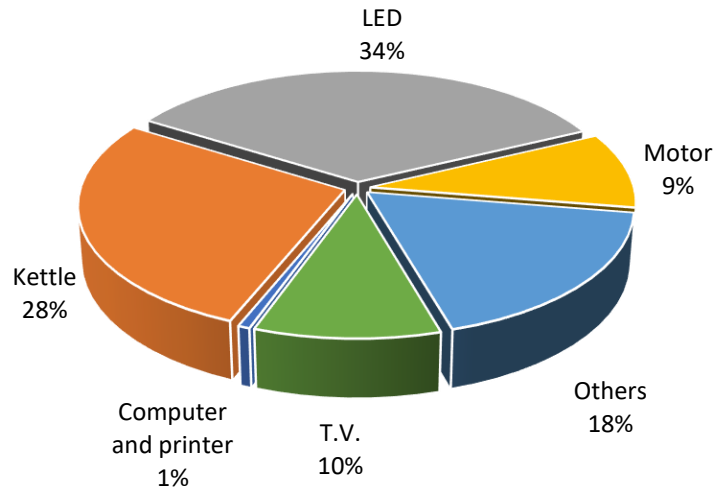

Figure 4.4 Daily Load Consumption

The pie chart above clarifies that the energy demand for LED is highest at 31%, followed by motors in mills, heater and kettle at 14%, 12% and 11% respectively. Similarly, TV consumes around 10% of the daily load and other devices like radio, mobile, street light etc. consumes round 9% of daily load. Due to the lower temperature in the concerned locality the demand for heating appliances like kettle and heater is high.

A daily load profile of electricity, also known as a daily load curve, refers to the graphical representation of how electricity consumption or demand fluctuates over the course of a typical day. Throughout a 24-hour period, electricity demand changes due to various factors such as human activities, industrial processes, weather conditions, and societal patterns. These variations lead to distinctive patterns in the load profile. The daily load profile below has been estimated by taking into account electrical load consumption by various electrical appliances at different periods of time in a day. As per the survey, demand of electricity is at peak at morning and evening time due to residential load mostly used for cooking and lighting at evening. This is due to the use of different load at once. Similarly, most of the load consumption during the day time is due to the use of mills and institutions during that time.

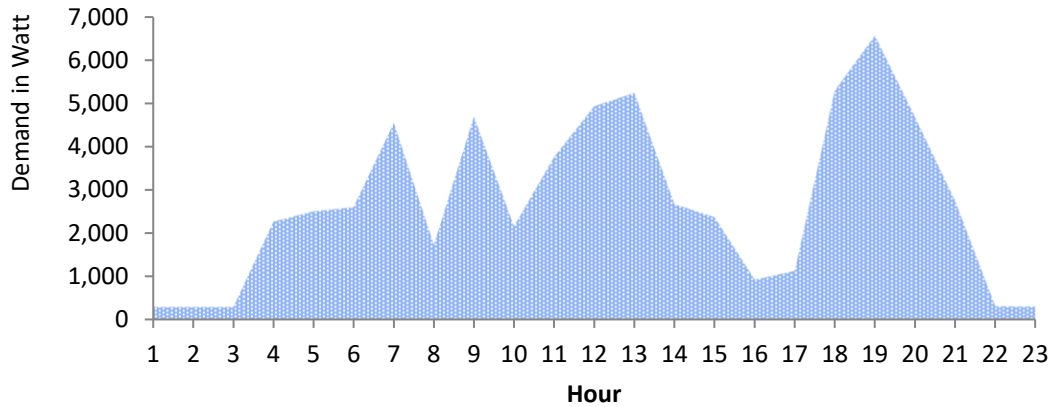

Figure 4.5 Daily load profile

Based on the daily energy requirement, the maximum energy required per day is calculated to be 62.4kWh. However, during the summer season (from April to June), the heating appliances (heater and kettle) will mostly not be used. And hence the energy consumed will be slightly more than half of the maximum energy demand in the rest of months.

The solar mini grid has been designed by considering the increase in load over next five years. According to the NEA standard, the load demand is estimated to increase by 5-7% annually. Similarly, there is an increase in around 1-2 households per year which will further increase the load demand. Overall, assuming that the energy demand is increasing at the rate of 5% per year. Also, as the energy demand increases the peak power also increases at a similar rate. The projected energy demand and peak power over is shown in Table 4.5.

Table 4.5 Demand Projection

| Years | 2022 | 2023 | 2024 | 2025 | 2026 |
|------------------------------|-------|-------|-------|-------|-------|
| Daily energy consumed in kWh | 65.39 | 68.51 | 72.22 | 75.84 | 79.63 |
| Peak power in kW | 6.88 | 7.22 | 7.58 | 7.96 | 8.36 |

The system is designed in such a way that current system required for these increased demands will be sufficient for next 5 years. However, there may need to add up panels as required. Moreover, the prepaid meter that limits per day energy consumption will act as a safeguard measure for increased load or in case the load gets out of limit. This way, the system will work efficiently and without failure.

4.3 Technical Configuration

The system parameters for the Solar PV mini grid are calculated for the daily load consumption and peak power that is projected for the year 2026 A.D. The solar PV mini grid designed for Dalaicha Danda village is an AC coupled mini grid with two different inverter i.e. grid tied inverter and battery inverter as in figure 4.5.

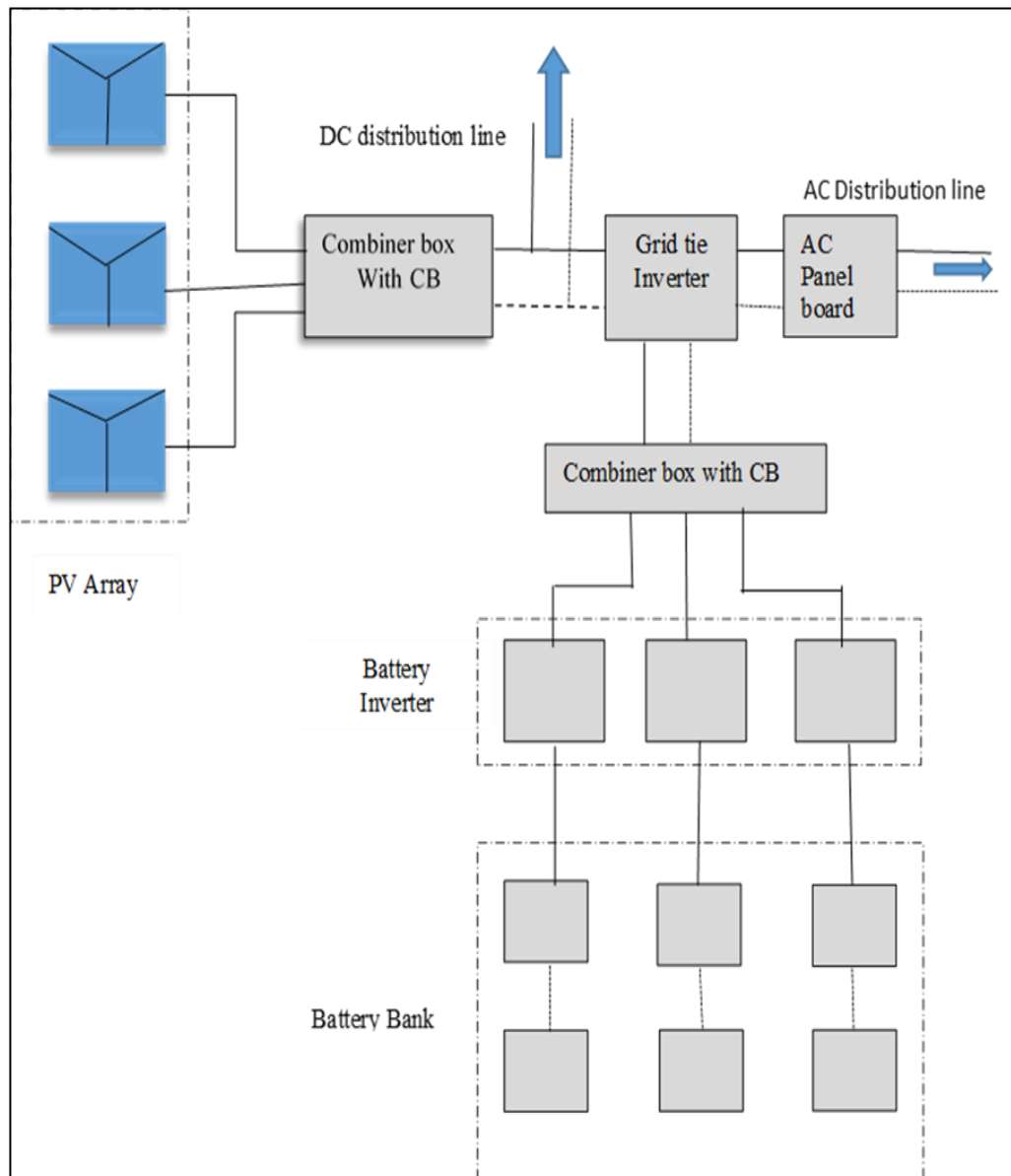

Figure 4.6 Solar Mini Grid

4.3.1 Solar PV Module

Solar energy is transformed into electrical energy using photovoltaic (PV) devices, which comprise semiconducting components. The term "cell" refers to a single PV device, whereas "module" or "panel" refers to the bigger units formed when many cells

are chained together. For the kind of load profile and renewable resources available at the site, the optimum design of the solar mini grid was found to be 9 kWp but due to the required input voltage of grid tied inverter, a 21 kWp solar PV mini grid that should be installed. This required power can be generated by connecting of 52 modules of 400Wp (Si-Poly) with specification as open circuit voltage of 47.2 V and short circuit current of 10.9. The total area required for installing 52 panels will be around 116 m².

Table 4.6 Specifications of solar panel

| | |
|----------------------------------|---|
| Size of Solar Mini Grid | 21 kWp |
| Specifications of Selected Panel | $P = 400\text{Wp}$, $\eta \geq 16\%$ $V_{oc} = 47.20\text{ V}$, $I_{sc} = 10.9\text{ A}$ |
| Number of Panels | 52 (13 strings of 4 in series panel) |
| Floor Area for Installment | 116 m ² . |

4.3.2 Grid Tied Inverter

The grid tied inverter with MPPT should be installed considering future grid expansion and the current PV array capacity. So, for Dalaicha Danda village a grid tied inverter of 20 kW is selected. The grid inverter has an operating voltage of 275-450V with a maximum input voltage of 500V. The required input voltage for the grid tied inverter can be generated by connecting 13 strings of 52 solar panels (400 Wp).

Table 4.7 Specifications of grid tied inverter

| | |
|----------------------------|-----------|
| Size of Grid Tied Inverter | 20kWp |
| Operating Voltage | 275-450 V |
| Maximum Input Voltage | 500 V |
| Output Voltage | 400V |

4.3.3 Battery Inverter

A power inverter converts DC to AC, resulting in varying AC frequencies depending on the device's design. Inverters do not produce power, but rather provide it from a DC source. A Battery inverter of 10 kVA is selected to control the charging and discharging of energy storage device. The inverter rating is selected based on the peak load of the next three years of Dalaicha Danda village.

Table 4.8 Battery Inverter

| | |
|-----------------------------|-------------------------------|
| Projected peak load | 10.33 |
| Battery inverter efficiency | 0.95 |
| Load power factor | 0.98 |
| Size of battery inverter | 14 kVA (2 inverters of 7 kVA) |
| Output waveform | Pure sine wave |

4.3.4 Battery Sizing

A total of 48 solar tabular batteries (2V, 2000 Ah) shall be used to store energy that shall be consumed by the consumers during the twilight and night duration and also during the day if the power generated by PV panel is not sufficient. 24 batteries of 2V should be connected in series to generate a DC bus voltage of 48V and 2 strings of 24 batteries is necessary to generate sufficient current.

During the calculation of battery size, Depth of discharge is taken to be 80% and columbic efficiency as 97%. As the power house is located in the hilly area where the temperature does not exceed 30°C no AC is required for cooling purpose. Similarly, this size of the battery bank is considered with autonomy period of 1.5 days.

Table 4.9 Specifications of battery

| | |
|---------------------------|--------------------------------|
| Size of battery bank | 192 kWh |
| Individual battery rating | 2V, 2000Ah@C10 |
| Battery type | Lead acid sealed battery |
| Columbic efficiency | 0.97 |
| Depth of discharge | 80% |
| Number of batteries | 48 (8 strings of 24 batteries) |

4.3.5 Solar Charge Controller

Solar charge controller is used to control the charging and discharging of the battery. Along with MPPT functions, solar charge controller has all the battery protection system inbuilt into the controller. A universal charge controller that can automatically adjust operating parameters depending upon the properties of the system should be selected. Since the DC system voltage of 48V is considered for Dalaicha Danda village and the solar pane of 21 kWp is selected, a solar charge controller of 500A ($\approx 436A$) is suitable for the system.

Nowadays as there is MPPT technology embedded into the grid tie inverters, it is not necessary to install the separate solar charge controller

4.3.6 Support Structure for PV Module

The ground mount fixed type support structure should be installed for PV solar PV array. It should be installed in such a way that it should utilize optimum land surface area and there should not be any shadow during the day time. MS hot dip galvanized iron rod should be used to develop the support structure and it should allow for easy cleaning of solar module.

Table 4.10 Specifications of support structure

| | |
|-------------------------------------|-------------------------------------|
| Material Used for Support Structure | MS hot dip galvanized iron |
| Tilt Angle and Orientation | 30 ⁰ , South facing |
| Minimum Ground Clearance | 80 cm (ground level to bottom edge) |

4.3.7 Conductor Selection

The conductors for the distribution system of the Dalaicha Danda are selected such that the distribution loss remains below 10%. Aluminum conductor steel-reinforced cable is selected for distribution purpose due to its high capacity and high strength. In the longest route an auto transformer should be installed to maintain voltage regulation. Similarly, Rabbit conductor (100 sq.mm.) is selected for 3 phase distribution along with single phase and 2 phase distribution. The sag length of 3% is considered while calculating the length of the conductor. The length of Rabbit conductor required for this installation is 7.5km. Rabbit conductor is also selected for the neutral wire and the overall length of neutral wire is 3.5 km.

4.3.8 Distribution Loss

The maximum voltage drop for such installation is below 8%. The details of the distribution loss in different paths is shown in ANNEX 3.

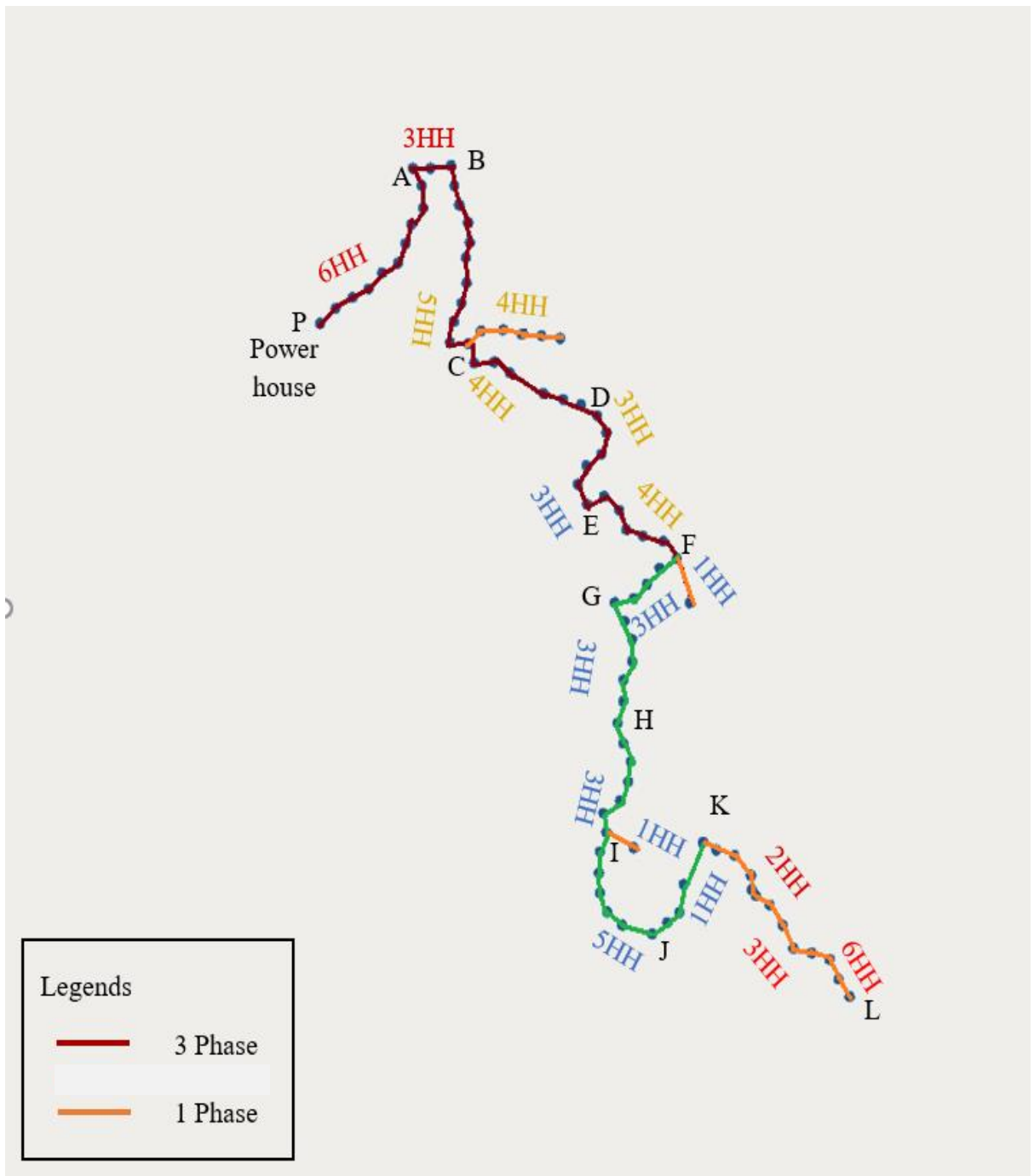

Figure 4.7 Distribution diagram of Dalaicha Village

4.4 Safety and Protection

a. DC Breakers

DC Breakers are very useful in solar system. If there is short circuit in panel side, it will trip down and protect the solar PV system from being damaged. DC breakers will limit its current to its rating. So, any extra current fallen on panel will be control by the DC Breaker.

b. Surge Protection Device (SPD)

The main function of the SPD is to restrict any shorts of spike at its input. Generally during lightning lots of spike falls on the earth or solar panel that will be controlled by SPD by grounding all those spikes. All SPDs has voltage and current rating. The lightning arrester (0.5KV) will be installed at the solar power plant and power house with the grounding.

c. Body Grounding

Body grounding is also very much important in power system. Any extra current can cause the system damage or severe injury to human. So proper grounding is essential in power system.

d. DC Fuses

DC Fuses also protects the system by disconnecting the system when it senses the drawing current or charging current is greater than its rating. All DC Fuses has its current rating.

e. AC Breakers

The AC breakers are generally installed on the output of the grid tied inverter and in the individual institutions/ households. The Breaker that is connected to the output side of inverter is Main Circuit Breaker. This Breaker will cut the power of distribution line including all the houses. So, during the maintenance one can trip down and work on the distribution line and service cables. The other Breaker is after the prepaid meter which will protect any shorts of fault in the house wiring.

f. Prepaid Meter

Prepaid meter can lock the peak power and fix energy of individual houses that is if any user wishes to switch the load that is beyond the lock peak power the meter itself will cut the power off that house only and when the user will disconnect the load which was beyond the peak power then s/he will get power again.

g. AC Isolator/Disconnect at Inverter

Where the inverter is not adjacent to the electrical panel to which it is connected, an isolator should be provided at the inverter so that a person operating the switch has a clear view of any person working on the inverter.

h. Solar Supply Disconnect in AC Panel

It is recommended that the interconnection of the grid connected PV system and the buildings electrical system is undertaken at an electrical panel or distribution board.

This connection shall be at an AC solar supply isolator located on the electrical panel (or distribution board) where the solar system is connected.

4.5 Economic and financial analysis

Based on the technical specifications, the total investment required for the installation of the solar mini grid in Dalaicha dada village of Mikawakhola Rural Municipality was calculated. All product costs, shipping costs, customs taxes, VAT, and system degradation factors have been taken into account for the economic and financial analysis.

4.5.1 Bill of Quantities with Cost

The different components required for the installation of solar mini grid along with the number of quantities required and the total cost is shown in Table 4.11.

Table 4.11 Bill of quantities of Power generation components

| S.N. | Item description | Unit | Quantity | Unit Price (NRs.) | Total Cost (NRs.) |
|------|--|------|----------|-------------------|-------------------|
| 1. | 400Wp Solar photovoltaic array | PCs | 52 | 25,000 | 1,300,000 |
| 2. | 20kWp Grid tie inverter with MPPT and in built surge protector | PCs | 1 | 75,000 | 75,000 |
| 3. | 7kVA (Battery inverter) | PCs | 2 | 100,000 | 200,000 |
| 4. | Battery (2000Ah, 2V) | PCs | 48 | 40,000 | 1,920,000 |
| 5. | Solar PV module structure | LS | 1 | 50,000 | 50,000 |
| 6. | PV string combiner box with accessories | Set | 1 | 75,000 | 75,000 |
| 6. | Off grid combiner box with accessories | Set | 1 | 25,000 | 25,000 |
| 10. | DC panel board with breaker and accessories | Set | 1 | 35,000 | 35,000 |
| 11. | AC Distribution center with accessories | Set | 1 | 100,000 | 100,000 |
| 11. | Earthing system | Set | 2 | 25,000 | 50,000 |
| 12. | Lighting Protection system | Set | 1 | 150,000 | 150,000 |
| 13. | Equipotential Bonding Bus bar | Set | 1 | 1,000 | 1,000 |

| S.N. | Item description | Unit | Quantity | Unit Price (NRs.) | Total Cost (NRs.) |
|------|-------------------------------|------|----------|-------------------|-------------------|
| 14. | Control and monitoring system | Set | 1 | 200,000 | 200,000 |
| 15. | Fire extinguisher | Set | 2 | 75,000 | 150,000 |
| 16. | Exhaust fan | Set | 2 | 3,000 | 6,000 |

For electrification of the power generated by PV solar mini grid involves the local utility installing a power transmission and distribution of appropriate size near or in the village and making power available to the village. The quantity of power transmission and power distribution component with their cost is shown in Table 4.12

Table 4.12 Bill of quantities of Power transmission and distribution component

| S.N. | Item description | Unit | Quantity | Unit Price (NRs.) | Total Cost (NRs.) |
|------|---|------|-----------|-------------------|-------------------|
| 1. | PVC insulated copper armoured AC cable 16 sq. mm. | Mtr | 40 | 1,000 | 40,000 |
| 2. | Earthing system complete set | Set | 3 | 20,000 | 60,000 |
| 3. | MS pole (8m) for 400V and 230V line | Nos | 90 | 18,000 | 1,620,000 |
| 4. | ACSR Rabbit conductor | mtr | 1100 0 | 70 | 5,250,000 |
| 7. | Shackle insulator (medium)(34x4+29x3+30x2) | Nos | 283 | 300 | 84,900 |
| 8. | Support hooks | Nos | 25 | 100 | 2,500 |
| 9. | Anchor clamp | Nos | 25 | 100 | 2,500 |
| 10. | Piercing connector for interconnection of service wire and insulator ACSR cable | Nos | 25 | 100 | 2,500 |
| 11. | Cable connector for dead end | Nos | 5 | 100 | 500 |
| 12. | Service wire , concentric 6 sq. mm. | mtr | 1500 | 30 | 45,000 |
| 13. | Lighting arrester 0.5 kV, 1.5 Ka | Nos | 25 | 700 | 17,500 |

| S.N. | Item description | Unit | Quantity | Unit Price (NRs.) | Total Cost (NRs.) |
|---------------------|---|------|----------|-------------------|-------------------|
| 14. | Stray set with accessories | set | 25 | 2,000 | 50,000 |
| 15. | MCB 5/6A DP 230V AC for household and club | Nos | 60 | 800 | 48,000 |
| 16. | MCB 16A DP 230VAC for non commercial institute | Nos | 1 | 800 | 800 |
| 17. | MCB holder boxes for household and institute | Nos | 65 | 500 | 32,500 |
| 18. | MCCB 25A TP 400V AC with pole mounted distribution box for business | Nos | 1 | 10,000 | 10,000 |
| 19. | Street lamp 9W LED | Nos | 22 | 8,000 | 11,000 |
| 20. | Prepaid meter | Nos | 60 | 8,000 | 480,000 |
| Total cost of goods | | | | | 12,094,700 |

4.6 Bill of Quantities of Services

Bill of quantities with services has been shown in Table 4.13.

Table 4.13 Bill of quantities with services

| S. N | Description | Unit | Quantity | Cost (NRs.) | Total Cost (NRs) |
|------|--|------|----------|-------------|------------------|
| 1. | Distribution pole installation and commissioning | Nos. | 90 | 5,000 | 450,000 |
| 2. | Conductor stringing with LA fitting | LS | 1 | 70,000 | 70,000 |
| 3. | Earthing set installation all Complete | Set | 1 | 50,000 | 50,000 |
| 4. | Stay set installation all Complete | Set | 1 | 80,000 | 80,000 |
| 5. | Fence for PV array | LS | 1 | 300,000 | 300,000 |
| 6. | Fence for Powerhouse | | 1 | 200,000 | 200,000 |

| S. N | Description | Unit | Quantity | Cost (NRs.) | Total Cost (NRs) |
|------------|---|------------|----------|-------------|------------------|
| 7. | Civil works for PV array Footing | Set | 1 | 250,000 | 250,000 |
| 8. | Installation, Commissioning and Testing of Solar Mini grid System | LS | 1 | 200,000 | 200,000 |
| 9. | Construction of Powerhouse | LS | 1 | 150,000 | 150,000 |
| 10. | Operation, Maintenance and Management of whole system | Per An-num | 1 | 250,000 | 250,000 |
| 11. | Transportation of all goods from Supplier's warehouse to subproject site including loading, unloading and packing | LS | 1 | 895,700 | 895,700 |
| 12. | Miscellaneous | | | | 9,600 |
| Total cost | | | | | 2,905,300 |

Based on the technical specifications, the total initial investment required for the installation of the solar mini grid in Dalaicha Dada of Mikawakhola Rural Municipality is around NRs.17,495,770 including 13% VAT as shown in Table 4.14.

Table 4.14 Cost estimate

| S.N. | Description | Cost in NRs. |
|------|--------------------------|--------------|
| 1. | Cost Of Goods | 12,094,700 |
| 2. | Cost of Services | 2,905,300 |
| 3. | Total Cost without VAT | 15,000,000 |
| 4. | Vat (13%) | 1,724,770 |
| 5. | Insurance (1%) | 150,000 |
| 6. | Contingency (4%) | 600,000 |
| 7. | Total Cost including VAT | 17,495,770 |

The above cost estimate does not consider the operation and maintenance cost along with battery replacement and the salary of the maintenance staff. Also solar panel, battery inverter and grid tie inverter are assumed to be tax exempt materials. Here it is assumed that operation and maintenance cost along the annual salary is NRs. 250,000 in the first year and increases 1% every year. Similarly, assuming that the price of the battery decreases by 10% in the next eight years, the overall price of battery replacement will be around NRs. 1,952,640.

Solar mini grids are recognized for their light environmental footprint and benefits for community health and safety, they also carry risks that could positively and negatively impact communities and the environment. Decision making about a mini grid must be informed by environmental, health and safety (EHS) risks. These risks affect people differently based on gender, age, ethnicity, health, livelihoods and economic status.

4.7 Sensitivity Analysis

Sensitivity analysis is the process of recalculating outcomes under alternative assumptions to determine the variable parameters. Sensitivity analysis provides lenders and investors the better understanding of the effect of changes in input on the profitability and bankability. Four scenarios are considered for the sensitivity analysis.

Table 4.15 Sensitivity Analysis table

| Plant lifecycle | 15 Years | | | |
|---|-----------------|-----------|---------|---------|
| Initial investment | NRs. 17,495,770 | | | |
| Scenarios | 1 | 2 | 3 | 4 |
| Grant (Nepal Government) | 0% | 60% | 90% | 90% |
| Grant (Ward Offices) | 50% | 0 | 0 | 10% |
| Equity @ 6% Interest rate (Community) | 25% | 20% | 10% | 0 |
| Loan @ 8% Interest rate | 25% | 20% | 0 | 0 |
| Average Annual Revenue required (NRs.) | 1,418,362 | 1,214,381 | 602,017 | 398,458 |
| Average average monthly tarrif/HH (NRs/KWh) | 1,876 | 1,606 | 796 | 527 |
| Average annually revenue generated (NRs.) | 410,554 | 410,554 | 410,554 | 410,554 |

| | | | | |
|---|-----------|-----------|---------|-------|
| NPV @10% discount rate (NRs.) | - | - | - | 14447 |
| | 7,612,830 | 6,061,335 | 1403644 | |
| Levelized cost of electricity (NRs/KWh) | 52.25 | 44.65 | 21.85 | 14.28 |

The sensitivity analysis under various scenarios is presented in Table 4.15. As the demand of the consumer increases by 5% each year, the revenue generated will also increase. Considering the degradation of solar PV array by 0.7% each year and overall efficiency of the system to be 80%, the solar mini grid will generate sufficient energy for the upcoming five year. Considering this the average annual revenue generated from the solar mini grid will be NRs. 410,554. Since the NPV of scenarios 1, 2 and 3 is negative there is no payback period. Only the scenarios 4 is financially feasible.

4.7.1 Comparison with Diesel Generator Supply Option

Diesel generators (DGs) are another alternative for supplying electricity in the mini grid method to fulfill the needs of rural communities, particularly because their capital investment is smaller than that of other energy technologies. In order to compare costs, DG would be better choice for the village's choice for electrification. For the cost analysis, a brushless, three-phase, 400 V DG with a power factor of 0.8, revolving field, and directly linked was used. To support the needs of the village's various end uses as well as the local residential lighting and appliance demands, a generator with a minimum output of 25 kW is required.

The technical and cost information of DG set is tabulated in Table 4.16.

Table 4.16 Technical and Cost information of DG set

| Description | Values |
|--|-----------|
| Diesel Generator capacity in Kw | 25 kW |
| System life span in hours | 20,000 |
| Diesel Generators and its accessories installation cost in NRs. | 1,500,000 |
| Capacity factor of DG | 60% |
| Cabling distribution cost (with 200HH/Km2 and 200HH and 4km/km2) | 1,085,000 |

| | |
|--|--------|
| Annual Operation and Maintenance cost (5% of Total DG installation cost) | 75000 |
| Fuel Tank Cost in NRs | 80,000 |
| Fuel Tank life in years | 3 |
| Diesel cost in the local market in NRs./ltr | 165 |
| Diesel price escalation | 4% |
| Estimated LCOE in NRs./KWh | 78 |

In this scenario, the DG set's projected LCOE is NRs. 78/kWh. A 4% fuel price escalation factor has been taken into account while determining LCOE. However, the price of fossil fuels is unstable on the global market, which also affects the local market's diesel price.

4.8 LCOE comparisons for various hybrid mini grids and mini grids

Diesel, solar PV, wind, biomass, and hydropower are some of the different technologies used in mini grid systems that may be evaluated for their economic viability and cost-competitiveness using the LCOE. It is calculated using the following equation and takes into account a number of factors, including the initial cost of the investment, O&M costs, incentives, resource availability, and fuel prices. (Brenna et al. 2016; Blum et al. 2013; IRENA, 2012)

$$\text{LCOE} = \frac{\text{sum of costs over lifetime}}{\text{sum of electrical energy produced over lifetime}} = \frac{\sum_{t=1}^n \frac{I_t + M_t + F_t}{(1+r)^t}}{\sum_{t=1}^n \frac{E_t}{(1+r)^t}}$$

I_t : investment expenditures in the year(t)

M_t : operations and maintenance expenditures in the year (t)

F_t : fuel expenditures in the year t

E_t : electrical energy generated in the year t

r : discount rate

n : expected lifetime of system or power station

The most popular generation technologies used in HRESs are solar photovoltaics (PV), wind, hydro, and biomass, which are commonly hybridized with diesel generators as a backup. However, over the last few years, the price of renewable energy, particularly solar and wind energy, has declined as a result of technological innovations, such as improvements in the production of wind turbine and solar PV design and the rise of benefits of scale.

Based on data retrieved from IRENA (2016), Figure 4.8 shows the predicted LCOE fluctuations between 2015 and 2035, which suggests that the LCOE as a whole would continue to decline up to 2035 for mini grids. Mini grids' LCOE in 2015 varied from \$0.47 to \$0.92 per kWh, while predictions for 2035 indicate that it would be between \$0.19 and \$0.35 per kWh.

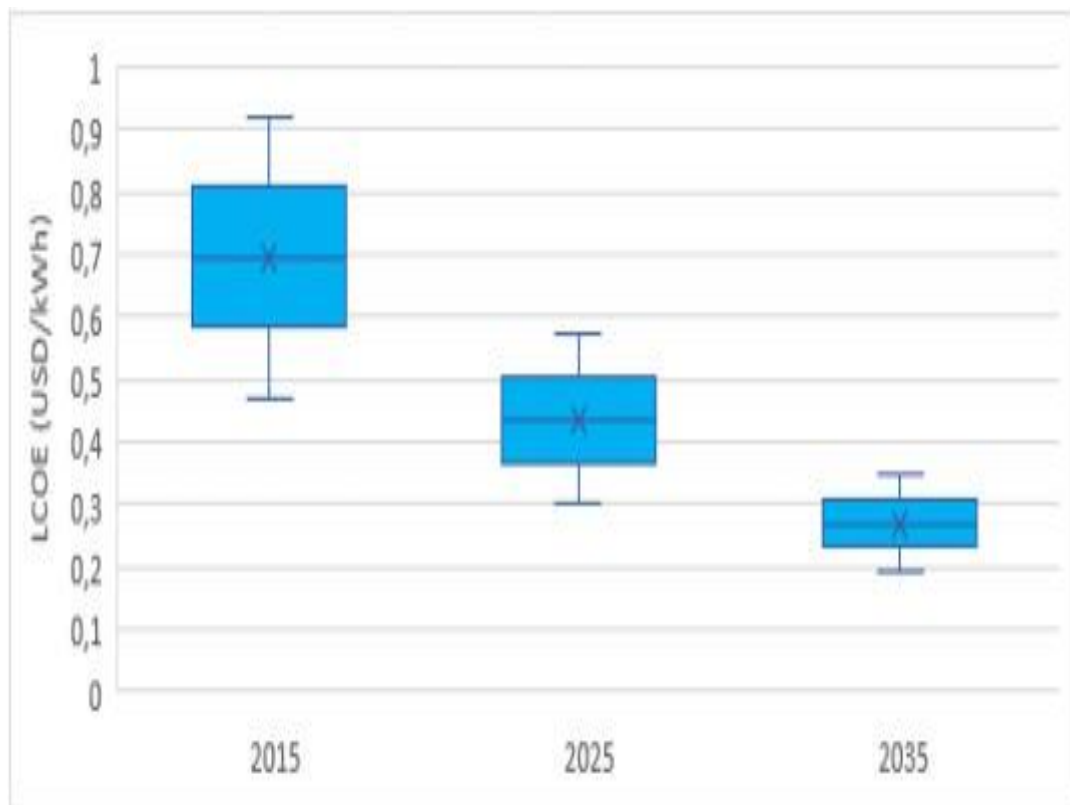

Figure 4.8 Mini grids' LCOE (2015–2035). IRENA (2016),

Figure 4.9 shows the reduction in LCOE for small wind, biomass micro grids and small-scale solar PV based on data from IRENA (2016). Solar PV's LCOE is anticipated to decrease from USD 0.15/kWh and USD 0.25/kWh in 2015 to USD 0.04–\$0.05 in 2035 and USD 0.09–\$0.14 in 2025, respectively. The LCOE for small wind is expected to significantly decrease up to 2023, after which it is predicted to reduce by 1% yearly. The LCOE for mini-hydro is expected to remain stable (0.27). As the cost of renewable

technologies falls and oil prices rise, mini grids are becoming more and more economically appealing.

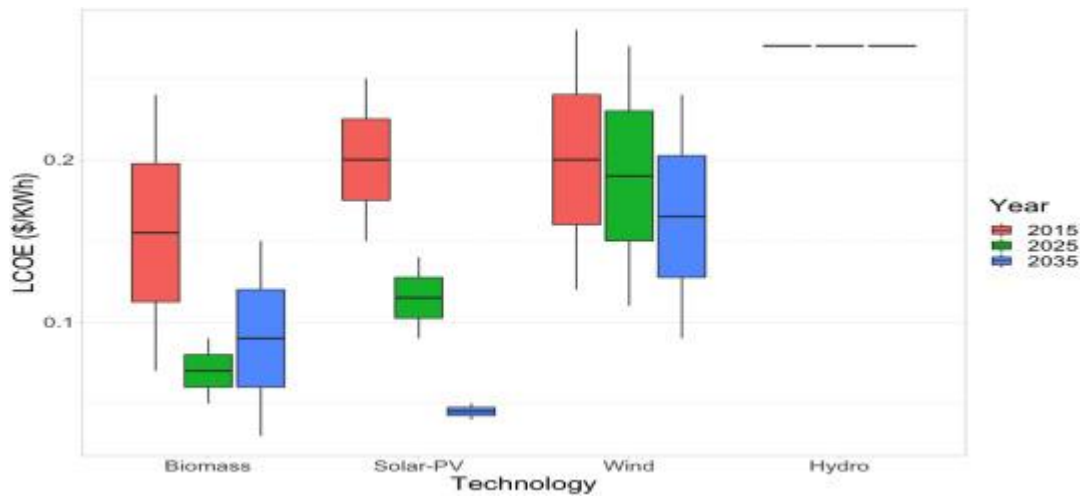

Figure 4.9 LCOE for various mini grids (2015–2035). IRENA (2016)

The Frankfurt School of Business (F.S., 2015) examined the economic and financial sustainability of diesel-only systems and hybridizations with solar PV at seven sites in Kenya, Indonesia, the Philippines, Saint Vincent and the Grenadines, the Dominican Republic, Colombia, and The Gambia. The study found that the LCOE of mini grids operated by diesel and solar PV ranges from USD 0.34/kWh to USD 0.47/kWh and USD 0.16/kWh to USD 0.22/kWh respectively. This demonstrates how solar PV is significantly more affordable than fuel.

Safdar (2017) claims solar PV mini grid offers more economically appealing LCOE compared to diesel generators, with a range of USD 0.47-0.71/kWh. However, depending on variables like unique government incentives, diesel prices may vary from one nation to the next. Diesel generator (DG) LCOE ranges from USD 0.23/kWh to 0.49/kWh, based on Indonesian fuel prices. (Blum et al. 2013), however, if worldwide fuel costs are considered, it is anticipated to fall between \$0.35 and \$0.50 per kWh. (IRENA, 2012).

According to the World Bank's 2017 State of Electricity Access Report, diesel generator micro grids are typically 0.43 cents per kWh more expensive than those powered by renewable energy. In contrast to Comello et al.'s (2017) evaluation of the diesel mini grid's LCOE to be USD 0.57/kWh, the LCOEs for hybrid solar/diesel and solar/battery were determined to be USD 0.55/kWh, and USD 0.38/kWh, respectively. The findings

show that combining diesel with renewable energy has the potential to lower fuel consumption and production costs in diesel-based small grids since 100% diesel micro grids are more expensive than hybrid solar/diesel mini grids.

According to IRENA's (2012) analysis of the technical and financial elements of biomass power generation technologies, the LCOE for a biomass gasifier ranges from USD 0.11 per kWh to USD 0.28 per kWh. Mini grids that use biomass as a gasifier feedstock to produce energy, however, incur substantial operational expenses.

The World Bank (2005) (ESMAP, 2007) analyzed the LCOE of numerous mini grids at specific size capacities in 2005, with projections for 2010 and 2015. The study found that the LCOE for 1 kW diesel, 25 kW solar PV mini grid, 100 kW wind mini grids, and 100 kW bio-mass gasifier ranges between USD 0.47/kWh and USD 0.58/kWh, depending on local resource availability. According to Ruud (2013), the LCOE for a 30 kW solar PV micro grid ranged from \$0.40 to \$0.61 per kWh., however a feasibility study in Kenya estimated the LCOE for a 10 MWp solar PV power plant to be \$0.21 per kWh. Deichmann et al. (2011) found that mini grids powered by wind in Africa have an average LCOE between 0.14/kWh and 0.29/kWh, depending on local resource accessibility. The information shown in Figure 4.10 was compiled from studies published in 2013 and 2017 by Advisory Services on Climate, Energy and Development Issues (ASCENDIS)(Akker, 2017), IRENA(Anoune et al., 2018), Ruud (2013), and the World Bank(Brenna at el. 2016), for capacities ranging from 20 kW to 100 kW. They offer comparisons between various hybrid mini grids and mini grids of various scales.

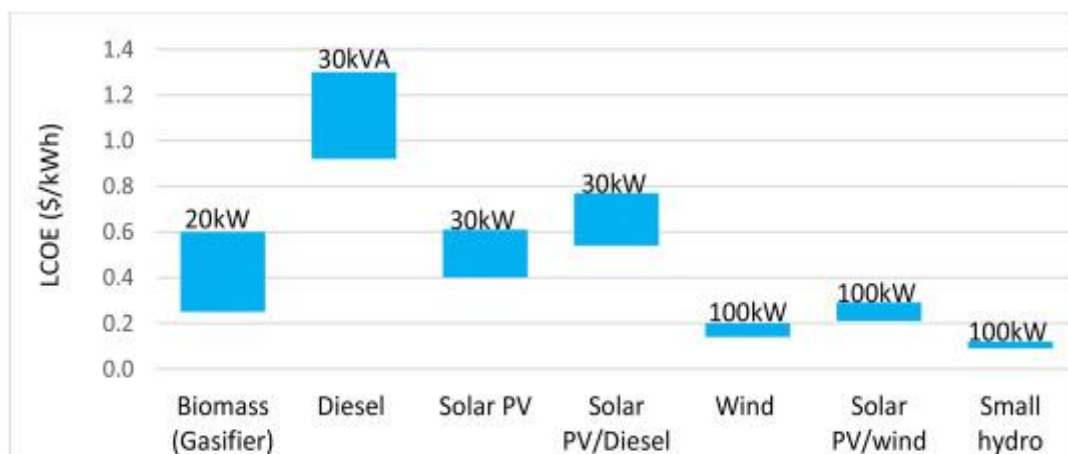

Figure 4.10 Different mini grid and hybrid mini grid's LCOE (USD/kWh).

Figure 4.10 shows that, in comparison to diesel and solar mini grids, small hydro and wind mini grids may generally be the least expensive solutions. However, they are very site-specific and rely heavily on the resources that are available. When compared to other generation sources, diesel mini grid has the highest LCOE and is most susceptible to changes in fuel prices. Another significant discovery was the possibility of reducing the costs of generating based solely on solar PV or diesel or solar PV and wind, respectively.

A number of studies have also been carried out using cost and system optimizing tools like the hybrid optimization model for electric renewables (HOMER) to evaluate hybrid micro/mini grids' techno-economic performance in various locales. Ramli et al. (2016) and Hiendro et al. (2013) used HOMER software to analyze hybrid solar PV/wind systems in Indonesia and Saudi Arabia. They found that the systems' LCOE differs, with prices varying based on nation, technology, capital, replacement, and O&M costs. This highlights the need for further research on hybrid solar PV/wind systems' techno-economic viability.

4.9 Social Impact

Implementations of solar mini grids have proved to have a positive impact on the community. Sharing limited resources and power among users in a mini grid requires rules and a tariff structure that ensures sustainability in the operation. The quality of life of the residents of the income generating activities of the community as residents of the locality can utilize electricity for their business and other activities.

The children in the community can utilize electricity to study during dawn and dusk period. Similarly, women of the community can utilize the electricity for lighting purposes during cooking and other activities. This will decrease the use of kerosene lamp and other CO and CO₂ releasing technology and hence decrease the indoor pollution and reduce various diseases.

4.10 Environmental Impact

Solar mini grids are recognized for their light environmental footprint and benefits for community health and safety, they also carry risks that could positively and negatively impact communities and the environment. Decision making about a mini grid must be informed by environmental, health and safety (EHS) risks. These risks affect people differently based on gender, age, ethnicity, health, livelihoods and economic status.

4.10.1 Positive Impact

In the installing phase, the solar mini grid has the minimum impact on the environment when compared to the other sources of power production. Solar mini grid can be installed on any type of land hence does not affect any agricultural land. Similarly, it does not require any tunneling, boring, mining etc. and hence has minimal effect on the vegetation.

In the operation phase, solar PV mini grid being a green technology offers no pollution to the environment, the air remains fresh. It replaces the tradition and conventional energy sources from coal power plants that increase the content of sulphur in the atmosphere thus causing acid rain, and petrochemicals such as gasoline, where carbon dioxide is released, and other toxic substance of public health concerns.

Climate change is an international concern to different governments around the world. There have been summits of various world leaders to make the earth habitable, and hence climate change is a threat to humanity. Solar energy is a promising technology that offers no emission of greenhouse gases and carbon dioxide.

Solar powerhouse does not create any noise and it requires less water for cleaning of solar panels. Rainwater is enough to clean the boards or panels when they get a bit grubby naturally and also does not require fossil fuels so the many advantages for our plants, especially when it comes to our environment.

4.10.2 Negative Impact

Solar PV Mini grid plants have the potency to cause environmental degradation and the loss of habitat. The degree of damage depends on the scalability of the technology, the land topography and the resources available for construction of the site. The materials to be used are proportional to the type of technology, like photovoltaic (PV) solar cells.

Solar systems design materials require maintenance and cleaning. Cleaning of these surfaces makes use of chemicals which are relatively toxic to humans. These chemicals include, hydrochloric acid, sulfuric acid, nitric acid, hydrogen fluoride, 1, 1, 1-trichloroethane and acetone which are similar to chemicals used in the semiconductor industry. The amount of these substances used depends on the type of solar system as iterated.

There were health complications when the storage units used to store heat energy is not ideal. Consequently, this may provide the perfect environment for the growth of molds and fungi that causes a different allergic reaction.

4.11 Problems and Barriers faced by Solar Mini grid in Nepal

Implementing solar mini grids, especially in developing countries or remote areas, can face various challenges and barriers. Some of the common problems and barriers associated with solar mini grids are:

- i. **High Initial Costs:** The upfront investment required to set up solar mini grids, including solar panels, battery storage, distribution infrastructure, and control systems, can be substantial. This cost can deter investors and communities from adopting this technology, even though solar energy is generally considered a long-term cost-effective solution.
- ii. **Financing and Funding:** Securing adequate financing for solar mini grid projects can be challenging, especially in areas with limited financial resources. Finding investors or securing loans might be difficult due to perceived risks, uncertain returns, or lack of awareness about the technology's benefits.
- iii. **Maintenance and Technical Expertise:** Ensuring the proper operation and maintenance of solar mini grids requires technical expertise. Many remote areas might lack qualified personnel to manage and repair these systems. This can lead to performance issues, reduced efficiency, and downtime if problems aren't addressed promptly.
- iv. **Battery Storage and Lifespan:** Battery storage is crucial for ensuring uninterrupted power supply during cloudy days or at night. However, battery technology can be expensive, and the batteries themselves have a limited lifespan. Replacing batteries can be a significant ongoing cost for mini grid operators.
- v. **Regulatory and Policy Challenges:** Navigating regulatory frameworks and obtaining necessary permits can be complex and time-consuming. Inconsistent or unclear policies might hinder the adoption of solar mini grids. Uncertainty regarding tariffs, grid connectivity, and technical standards can also create obstacles.
- vi. **Social and Cultural Factors:** Community engagement and awareness are essential for successful mini grid implementation. Convincing local communities about the benefits of solar energy, addressing cultural preferences, and ensuring that the technology aligns with their needs and practices are important aspects that can affect adoption.

- vii. Demand Variability: Predicting energy demand accurately is crucial for designing appropriately sized solar mini grids. Mismatches between supply and demand can result in either underutilized systems or insufficient power during peak demand, both of which can impact the viability of the mini grid.
- viii. Grid Extension Competition: In some cases, the option of extending the main grid to remote areas might compete with the adoption of solar mini grids. The perceived reliability of the main grid might sway decisions away from mini grid solutions.
- ix. Geographical and Climatic Challenges: In regions with harsh climatic conditions, such as extreme cold or humidity, the performance of solar panels and batteries might be affected. Additionally, accessing remote and mountainous areas for installation and maintenance can be logistically challenging.

CHAPTER FIVE: CONCLUSIONS AND RECOMMENDATIONS

5.1 Conclusions

Following conclusions has been drawn from the study

- Dalaicha Danda village in Mikawakhola Rural Municipality, Ward no. 4, Taplejung, Province 1 contains a total of 60 households along with 2 clubs, 2 commercial building and 1 non commercial building. The average energy demand of the project site is around 62.4kWh and a peak demand of k occurs around 7:00 PM. The detail feasibility study of solar mini grid at Dalaichavillage suggest that it is technically feasible to install an AC coupled solar mini grid.
- The design of solar mini grid in PV system suggests that the solar PV array of kW is sufficient to supply the load demand of Dalaicha village. For these 52 solar panels of 440kW ($I_{sc}= 10.9A$, $V_{oc}=47.2$ & $eff. =16\%$) is selected. The solar panel should be arranged in such a way that it should provide sufficient input to the grid tied inverter. In case Dalaicha Danda village 13 strings of 4 solar panel is recommended. Considering future expansion of national grid, a 3-ph grid tied inverter of 20kW is selected the grid tied which requires an input operating voltage of 275-450V and supplies a voltage of 400V.
- A battery bank of 192kWh is selected to supply the electric loads during the night time and when the output of the PV array is not sufficient. 2V, 2000Ah batteries is considered to store energy. A total of 48 batteries (8 strings of 24 batteries) is selected to supply sufficient current and maintain a DC voltage of 48V. The charging and discharging of the battery is controlled by the 2 battery string inverters each of & 7KVA (total = 14 kVA). Since the modern inverters contain embedded MPPT controllers a separate MPPT controller is not required.
- For the distribution purposes, rabbit conductor (50 sq.mm.) is selected. 11 Km of rabbit conductor is required considering a sag of 3% to distribute the electricity to the households. The phase balance should be done in such a way that the distribution losses does not exceed 10%. Similarly, 8-meter poles should be installed to support the distribution wires. The gap between two poles should be kept at maximum distance of 40m.
- Financially, the solar mini grid is feasible only when financed according to the scenarios 3 and 4 i.e. with a grant of 90% from the government. Considering

the required average monthly tariff/HH the scenario 4 is the most appropriate where the financing is done completely through the grant (90% from Nepal Government and 10% from the ward office). In this scenario the solar mini grid will be self-sustainable and will generate sufficient revenue for the battery replacement. Also, this scenario is the one that was proposed by the ward office during the field visit. In this scenario, the NPV is NRs. 691,178 and the LCOE is 0.77.

5.2 Recommendations

There are some short comings to this project and therefore, I suggest the following recommendations for future work.

- The solar mini grid project will play a pivotal role where the reach of national grid is not anticipated for next 10 years.
- Educate and equip local populations in the use and upkeep of solar micro grid installations. Building local expertise will ensure the sustainability and longevity of the projects.
- Provisions should be made to integrate solar mini grid with national grid in future to explore the potential from bidirectional energy flows between mini grid and the main grid. This will prevent mini grid from being phase out.

REFERENCES

- A. Hiendro, R. Kurnianto, M. Rajagukguk, Y.M. Simanjuntak, Junaidi Techno-economic analysis of photovoltaic/wind hybrid system for onshore/remote area in Indonesia Energy, 59 (2013), pp. 652-657, 10.1016/j.energy.2013.06.005
- AEPC. (2022, june). Guidelines for the feasibility study of solar mini grid projects. Retrieved from <https://www.aepc.gov.np/uploads/docs/guidelines-for-the-feasibility-study-of-solar-mini-grid-projects-1654685783.pdf>
- Akker JHA Van Den Overview of costs of sustainable energy technologies Westerhoven (2017)
- Al-Karaghoul A, Kazmerski LL. Optimization and life-cycle cost of health clinic PV system for a rural area in southern Iraq using HOMER software. Solar Energy 2010;84(4): 710–4.
- Alliance for Rural Electrification Risk Management for Mini grids: a new approach to guide mini grid deployment (2014)
- Alternate Energy Promotion Centre (AEPC). (2018).
- Askari IB, Ameri M. Techno-economic feasibility analysis of stand-alone renewable energy systems (PV/bat, wind/bat and Hybrid PV/wind/bat) in Kerman, Iran. Energy Sources, PartB: Economics, Planning and Policy 2011;7 (1):45–60.
- Awasthi, A., Shukla, A. K., Murali Manohar, S. R., Dondariya, C., Shukla, K. N., Porwal, D., & Richhariya, G. (2020). Review on sun tracking technology in solar PV system. In Energy Reports (Vol. 6, pp. 392–405). Elsevier Ltd. <https://doi.org/10.1016/j.egy.2020.02.004>
- Ayompe, L. M., Duffy, A., McCormack, S. J., & Conlon, M. (2011). Measured performance of a 1.72 kW rooftop grid connected photovoltaic system in Ireland. Energy conversion and management, 52(2), 816-825.
- Azimoh, C. L., Klintonberg, P., Wallin, F., Karlsson, B., & Mbohwa, C. (2016). Electricity for development: Mini grid solution for rural electrification in South Africa. Energy Conversion and Management, 110, 268–277. <https://doi.org/10.1016/j.enconman.2015.12.015>

Bajracharya, T. R. (2019). Study on Effective Technical Audit of Grid Connected Solar PV. Proceedings of 12th IOE Graduate Conference .

Bhandari, B., Lee, K. T., Lee, C. S., Song, C. K., Maskey, R. K., & Ahn, S. H. (2014). A novel off-grid hybrid power system comprised of solar photovoltaic, wind, and hydro energy sources. *Applied Energy*, 133, 236–242. <https://doi.org/10.1016/j.apenergy.2014.07.033>

Bhattarai, A. (2013)., Performance Analysis of One Kilowatt Grid Connected PV System, Institute of Engineering, Tribhuvan University, Kathmandu.

C. Kost, J.N. Mayer, J. Thomsen, N. Hartmann, C. Senkpiel, S. Philipps, et al. Levelized cost of electricity: renewable energy technologies Fraunhofer Inst Sol Energy Syst ISE, 50 (2013), 10.1613/jair.301

C. Ruud Why not go green ? - an analysis of the viability of solar PV mini grids in Tanzania Norwegian University of Life Sciences (2013)

CADEC, A. (2004). ESAP (2005). Status of Solar Photovoltaic Sector in Nepal.

Comello, S. D., Reichelstein, S. J., Sahoo, A., & Schmidt, T. S. (2017). Enabling Mini grid Development in Rural India. *World Development*, 93, 94–107. <https://doi.org/10.1016/j.worlddev.2016.12.029> consideration of SHS. In: Proceedings of the 2010 international conference

El Mnassri M., Leger A. S. Stand alone photovoltaic solar power generation system: a case study for a remote location in Tunisia 2010.

Energy for all: financing access for the poor. Paris: International Energy Agency.

Environmental and Social Management Framework for Nepal: Private Sector-led Mini grid Energy Access Project Government of Nepal Ministry of Energy, Water Resources and Irrigation.

ESMAP Technical and economic assessment of off-grid, mini grid and grid electrification technologies (2007).

F.S. Collaborating, S.E. Finance Renewable energy in hybrid mini grids and isolated grids: economic benefits and business cases (2015).

Fs-UNEP Collaborating Centre Global trends in renewable energy investments 2018(2018)

Frankfurt: https://doi.org/http://report.mitigation2014.org/report/ipcc_wg3_ar5_annex-ii.pdf

IRENA and CPI Global landscape of renewable energy finance 2018(2018) Abu Dhabi
IRENA Policies and regulations for private sector renewable energy mini grids(2016).

IRENA Renewable energy technologies: cost analysis series Biomass Power
Gener, 1 (2012), p. 60, 10.1016/B978-0-08-098330-1.00011-9

IRENA Renewable power generation costs in 2012 : an overview Abu Dabi (2012).

IRENA. (2016). Innovation Outlook: Renewable mini grids (International Renewable
Energy Agency).https://www.irena.org/media/Files/IRENA/Agency/Publication/2016/IRENA_Innovation_Outlook_Mini_Grids_2016.pdf).

IRENA. Rethinking Energy Accelerating the global transformation, vol. 55 (2017) Abu
Dhabi: 2017.

IRENA Renewable power generation costs in 2017(2018) Abu Dhabi

IRENA The power to change: solar and wind cost reduction potential to 2025(2016)
Abu Dhabi

J. Ondraczek Are we there yet? Improving solar PV economics and power planning in
developing countries: the case of Kenya Renew Sustain Energy Rev, 30 (2014),
pp. 604-615, 10.1016/j.rser.2013.10.010

JICA. Preparatory survey on the project for clean energy promotion using solar photo-
voltaic system in nepal. 2010.

K. Anoune, M. Bouya, A. Astito, A Ben Abdellah Sizing methods and optimization
techniques for PV-wind based hybrid renewable energy system: a review Renew Sus-
tain Energy Rev, 93 (2018), pp. 652-673, 10.1016/j.rser.2018.05.032

Kamalapur G.D., Uday kumar R.Y. Electrification in rural areas of India and Khan
A.H., Khan M.F., Mostafa R. Solar P.V. as an effective alternative to oil based lamp
in the rural Bangladesh. In: Proceedings of the 2nd international conference on the de-
velopments in renewable energy technology (ICDRET); 2012.

Kumar, J., Agarwal, A., & Agarwal, V. (2019). Optimized design of mini grid system
for hilly region. IETE Journal of Research, 112. <https://doi.org/10.1080/03772063.2019.1620642> [Web of Science ®]

- M. Brenna, F. Foadelli, M. Longo, T.D. Abegaz Integration and optimization of renewables and storages for rural electrification *Sustain Times*, 8 (2016), 10.3390/su8100982.
- M.A.M. Ramli, A. Hiendro, Y.A. Al-Turki Techno-economic energy analysis of wind/solar hybrid system: case study for western coastal area of Saudi Arabia *Renew Energy*, 91 (2016), pp. 374-385, 10.1016/j.renene.2016.01.071.
- Magni, R., Alberg, P., & Hanlin, R. (2022). Energy for sustainable development hybrid photovoltaic and wind mini grids in Kenya: Techno-economic assessment and barriers to diffusion. *Energy for Sustainable Development*, 54(2020), 111–126. <https://doi.org/10.1016/j.esd.2019.11.002>.
- Mahela, O. P., & Shaik, A. G. (2017). Comprehensive overview of grid interfaced solar photovoltaic systems. In *Renewable and Sustainable Energy Reviews* (Vol. 68, pp. 316–332). Elsevier Ltd. <https://doi.org/10.1016/j.rser.2016.09.096>.
- Mainali, B. (2011). *Renewable Energy Market for Rural Electrification in Developing Countries: Country Case Nepal*. Industrial Engineering and Management, KTH Royal Institute of Technology.
- Maliro, P., Diarra, B., & Samikannu, R. (2022). Technical and economic feasibility assessment for a solar PV mini grid for Matekenya village. *Cogent Engineering*, 9(1). <https://doi.org/10.1080/23311916.2022.2110707>.
- N.U. Blum, R. Sryantoro Wakeling, T.S. Schmidt Rural electrification through village grids - assessing the cost competitiveness of isolated renewable energy technologies in Indonesia *Renew Sustain Energy Rev*, 22 (2013), pp. 482-496, 10.1016/j.rser.2013.01.049.
- NEA (2011), Nepal Electricity Authority. Annual report of fiscal year 2011/12. 2011.
- NEA (2019), Annual Report, Nepal Electricity Authority, Kathmandu.
- NEA (2020), Nepal Electricity Authority. Annual report of fiscal year 2020/21. 2020.
- on industrial and information systems (ICIIS); 2010.
- Outlook, I. (2016). *Renewable mini grids*. International Renewable Energy Agency, Abu Dhabi.

- Palit, D., & Chaurey, A. (2011). Off-grid rural electrification experiences from South Asia: Status and best practices. *Energy for Sustainable Development*, 15(3), 266–276. <https://doi.org/10.1016/j.esd.2011.07.004>.
- Pedersen, M. B. (2016). Deconstructing the concept of renewable energy-based mini grids for rural electrification in East Africa. *Wiley Interdisciplinary Reviews: Energy and Environment*, 5(5), 570–587. <https://doi.org/10.1002/wene.205>,
- Peters, J., Sievert, M., & Toman, M. A. (2019). Rural electrification through mini grids: Challenges ahead. *Energy Policy*, 132, 27–31. <https://doi.org/10.1016/j.enpol.2019.05.016>.
- Post, K. (2020). kathmandupost.com. Retrieved from kathmandupost.com: <https://kathmandupost.com/national/2020/11/28/plan-for-airport-in-bhairahawa-to-be-fully-solar-powered-gains-momentum>.
- Rapapate N., Göl Ö. Use of photovoltaic systems for rural electrification in Thailand. In: *Proceedings of the International Conference on Renewable Energies and Power Quality*, Sevilla, Spain; 2007.
- S. Schlömer, T. Bruckner, L. Fulton, E. Hertwich, A. McKinnon, D. Perczyk, et al.
- S.D. Comello, S.J. Reichelstein, A. Sahoo Enabling mini grid development in rural India *World Dev*, 93 (2017), pp. 94-107, [10.1016/j.worlddev.2016.12.029](https://doi.org/10.1016/j.worlddev.2016.12.029).
- Sajendra Man Bajracharya and Sanjeev Maharjan. Techno economic analysis of grid tied solar system: A case study of nepal telecom, sundhara, kathmandu. In *Proceedings of IOE Graduate Conference*, 2019.
- Samy, M. M., Mosaad, M. I., El-Naggar, M. F., & Barakat, S. (2021). Reliability support of undependable grid using green energy systems: Economic study. *IEEE Access*, 9, 31 December, 14528–14539. <https://doi.org/10.1109/ACCESS.2020.3048487>.
- Saulo, M. J. (2015). Design and Analysis of Solar Energy Mini grid for Rural Electrification. *Open Access Library Journal*, 2(09), 1.
- Sector Synopsis Report Nepal. (2010). www.wec.gov.np.
- Shakya, A. K., & Shrestha, J. N. (2015). Case study on grid integrated solar pv for national dasaratha stadium. *Proceedings of IOE Graduate*, 322-332.

Shakya, B., Bruce, A., & MacGill, I. (2019). Survey based characterization of energy services for improved design and operation of standalone microgrids. *Renewable and Sustainable Energy Reviews*, 101, 493–503. <https://doi.org/10.1016/j.rser.2018.11.016>

∴

Sharma, R., & Goel, S. (2017). Performance analysis of a 11.2 kWp roof top grid connected PV system in Eastern India. *Energy Reports* 3, 76-84.

Sharma, V., & Chandel, S. S. (2013). Performance analysis of a 190 kWp grid interactive solar photovoltaic power plant in India. *Energy* 55, 476–85.

Shrestha, A., Bishwokarma, R., Chapagain, A., Banjara, S., Aryal, S., Mali, B., Thapa, R., Bista, D., Hayes, B. P., Papadakis, A., & Korba, P. (2019). Peer-to-Peer Energy Trading in Micro/Mini grids for Local Energy Communities: A Review and Case Study of Nepal. In *IEEE Access* (Vol. 7, pp. 131911–131928). Institute of Electrical and Electronics Engineers Inc. <https://doi.org/10.1109/ACCESS.2019.2940751>

Shrestha, U., & Shrestha, J. N. (2014). A Techno-Economic Analysis of Utility Scale Photovoltaic Plant, A Case Study of 1 MWp Plant at Trishuli, Institute of Engineering Graduate Conference, Kathmandu, Pg. 468-475

Silva SB, Severino MM, de Oliveira MAG. A stand-alone hybrid photovoltaic, fuel cell and battery system: a case study of Tocantins, Brazil. *Renewable Energy* 2013;57(0):384–9.

T. Safdar Business models for mini grids: technical report 9 (2017).

The Mini grids Partnership (MGP). (2020). State of the Global Mini grids Market Report 2020 (Bloomberg NEF and Sustainable Energy for All), https://MiniGrids.org/wp-content/uploads/2020/06/Mini_grids_Market_Report-20.pdf.

Tiwari, B. R., Bhattarai, N., & Jha, A. K. (2017, December). Performance analysis of a 100 kwp grid connected solar photovoltaic power plant in kharipati, bhaktapur, Nepal. In *Proceedings of the IOE Graduate Conference, Patan, Nepal* (Vol. 5).

Tselepis S. Electrification with solar powered mini grids, a case study for the island of Kythnos. In: *Proceedings of 3rd World conference on photovoltaic energy conversion*; 2003.

U. Deichmann, C. Meisner, S. Murray, D. Wheeler The economics of renewable energy expansion in rural Sub-Saharan Africa *Energy Pol*, 39 (2011), pp. 215-227, 10.1016/j.enpol.2010.09.034

World Bank State of electricity access report 2017(2017).

Wu, Y., Wu, Y., Cimen, H., Vasquez, J. C., & Guerrero, J. M. (2021). Towards collective energy Community: Potential roles of microgrid and blockchain to go beyond P2P energy trading. *Applied Energy*, 314(December), 119003. <https://doi.org/10.1016/j.apenergy.2022.119003> 2022

ANNEXES

ANNEX-1: SURVEY QUESTIONNAIRE

Questionnaire for Detail Feasibility Study (DFS) of
Solar Mini Grid Sub-project

The following questions are intended to collect site information while conducting DFS of Solar Mini Grid Subprojects.

| | |
|----------------------------------|---------------------|
| Subproject Name: | |
| Rural Municipality/Municipality: | District: |
| Ward No/Tole: | Date of Site Visit: |

1. General Information:

1.1 Local Persons contacted or Interviewed (including Rural Municipality/Municipality/Ward Chairpersons):

| S.N. | Name of the Person Interviewed | Address | Contact Number | Signature |
|------|--------------------------------|---------|----------------|-----------|
| 1 | | | | |
| 2 | | | | |
| 3 | | | | |
| 4 | | | | |

1.2 Site Accessibility:

Name of nearest road-head:

Road-head type: Black-coated () Gravel () others ()

Walking distance from nearest road head to the subproject site:km

If no road access, walking distance from airport to proposed subproject site:
.....km

Name of the nearest airport:

Time for loaded porter to reach the site from road/airfield.....

Comments, if any:

.....

1.3 Demographic Information:

Number of households in the base year:

Base year population:

Percentage of Male and Female:

1.4 NEA National Grid

Name of the nearest NEA grid point:

Distance from proposed subproject site: km

Comments, if any:

1.5 Micro-hydro Power Plants in Area (if exist)

| Location | Size (kW) | Distance (km) | Monthly Tariff (NRs/kWh) | Comments |
|----------|-----------|---------------|--------------------------|----------|
| | | | | |
| | | | | |

2. Socio-Economic Survey:

2.1 Households and Population of the proposed village:

| S.N. | Name of Tole | Number of HH | Population | | Remarks |
|------|--------------|--------------|------------|--------|---------|
| | | | Male | Female | |
| 1 | | | | | |
| 2 | | | | | |
| 3 | | | | | |
| 4 | | | | | |
| 5 | | | | | |

2.2 Source of household income:

| S.N. | Particular | Share (%) |
|------|--------------------------------|-----------|
| 1 | Agricultural production | |
| 2 | Service/Jobs except remittance | |
| 3 | Income from remittances | |
| 4 | Anchor/Business | |
| 5 | Others, if any | |

2.3 Are there any indigenous people living in subproject area?

If yes, provide the details.

.....

.....

2.4 Total no of existing anchors or businesses:

| S.N. | Name of Anchor/Business | Type of Products being produced | Annual Production Capacity | Source of energy being used |
|------|-------------------------|---------------------------------|----------------------------|-----------------------------|
| 1 | | | | |
| 2 | | | | |
| 3 | | | | |

2.5 After installation of solar mini grid system, is there any possibility of entrepreneurship development? If so, please list out the potential anchor or business.

-
-
-
-

2.6 Households willingness to pay for monthly electricity tariff?

AverageNRs/kWh

2.7 Anchors/Businesses willingness to pay for monthly electricity tariff?

AverageNRs/kWh

2.8 Institutions (community uses) willingness to pay for monthly electricity tariff?

AverageNRs/kWh

2.9 Enabling Environment:

| Items | Excellent | Very good | Good | Fair | Poor | Comments |
|---|-----------|-----------|------|------|------|----------|
| General Interest in solar, mini grid | | | | | | |
| Understanding the safety related in electricity use | | | | | | |
| Understanding about paying for electricity | | | | | | |
| Understanding of tariff structure | | | | | | |

| | | | | | | |
|---|--|--|--|--|--|--|
| Understanding of need for operational costs | | | | | | |
| Understanding about anchor/business | | | | | | |

Other Comments, if any:

3. Present Situation and Electricity Demand:

3.1 Present Source of Electricity in the village:

| S.N. | Types of Power supply | No of HH | No of Anchors/ Businesses | No of Institutions (community uses) | Remarks |
|------|--------------------------|----------|------------------------------|-------------------------------------|---------|
| 1. | Solar home systems | | | | |
| 2. | Small solar home systems | | | | |
| 3. | Pico-hydro | | | | |
| 4. | Micro-hydro | | | | |
| 5. | Kerosene | | | | |
| 6. | Diesel Generator set | | | | |
| 7. | Others, if any | | | | |

3.1 Average Household Power Demand (Please use the list or edit as required):

| S.N. | Appliances/Equip-ments | Quan-tity (A) | Estimated Watt per Unit (B) | Total Power (Watt) $C = A * B$ | Average daily use (Hour/day) |
|------|------------------------|---------------|-----------------------------|-----------------------------------|------------------------------|
| 1. | LED Lights | | | | |
| 2. | Radio | | | | |
| 3. | Mobile Charging | | | | |
| 4. | Television | | | | |
| 5. | DTH Receiver | | | | |
| 6. | Fan | | | | |
| 7. | Laptop | | | | |
| 8. | Refrigerator | | | | |
| | Others, if any | | | | |
| | Total Power (Watt) | | | | |

ANNEX 2: LOAD PATTERN

| Particulars | Rated Power (W) | Qty in use | Time | | | | | | | | | | | | | | | | | | | | | | | | Wh / day | Total Wh /day | | | | | |
|---------------------------------|-----------------|------------|------|---|---|---|---|-----|---|-----|---|----|----|----|---|---|---|---|---|---|---|---|---|----|----|----|----------|---------------|---|---|----|------|------|
| | | | 1 | 2 | 3 | 4 | 5 | 6 | 7 | 8 | 9 | 10 | 11 | 12 | 1 | 2 | 3 | 4 | 5 | 6 | 7 | 8 | 9 | 10 | 11 | 12 | | | | | | | |
| Package A (10 Household) | | | | | | | | | | | | | | | | | | | | | | | | | | | | | | | | | |
| LED Light(toilet) | 3 | 1 | | | | | 1 | | | | | | | | | | | | | | | | | | | 1 | 1 | 1 | 1 | | | 15 | 150 |
| LED Light(goth) | 3 | 1 | | | | | 1 | 1 | | | | | | | | | | | | | | | | | | | 1 | 1 | 1 | | | 15 | 150 |
| LED Light(kitchen) | 5 | 1 | | | | | 1 | 1 | | | | | | | | | | | | | | | | | | | 1 | 1 | 1 | 1 | | 30 | 300 |
| LED Light(room) | 5 | 1 | | | | | 1 | 1 | | | | | | | | | | | | | | | | | | | 1 | 1 | 1 | | | 25 | 250 |
| LED Light(room) | 5 | 1 | | | | | 1 | 1 | | | | | | | | | | | | | | | | | | | 1 | 1 | 1 | | | 25 | 250 |
| Charger | 5 | 2 | | | | | | 0.5 | | | | | | | | | | | | | | | | | | | 1 | 1 | 1 | | | 35 | 350 |
| Radio | 5 | 1 | | | | | | | | 0.5 | | | | | | | | | | | | | | | | 1 | 1 | 1 | 1 | | | 27.5 | 275 |
| Prepaid Meters | 1 | 1 | 1 | 1 | 1 | 1 | 1 | 1 | 1 | 1 | 1 | 1 | 1 | 1 | 1 | 1 | 1 | 1 | 1 | 1 | 1 | 1 | 1 | 1 | 1 | 1 | 1 | 1 | 1 | 1 | 24 | 240 | |
| Package B (30 Household) | | | | | | | | | | | | | | | | | | | | | | | | | | | | | | | | | |
| LED Light(toilet) | 3 | 1 | | | | | 1 | | | | | | | | | | | | | | | | | | | | 1 | 1 | 1 | 1 | | 15 | 450 |
| LED Light(goth) | 3 | 1 | | | | | 1 | 1 | | | | | | | | | | | | | | | | | | | 1 | 1 | 1 | | | 15 | 450 |
| LED Light(kitchen) | 5 | 1 | | | | | 1 | 1 | | | | | | | | | | | | | | | | | | | 1 | 1 | 1 | 1 | | 30 | 900 |
| LED Light(room) | 5 | 1 | | | | | 1 | 1 | | | | | | | | | | | | | | | | | | | 1 | 1 | 1 | | | 25 | 750 |
| LED Light(room) | 5 | 1 | | | | | 1 | 1 | | | | | | | | | | | | | | | | | | | 1 | 1 | 1 | | | 25 | 750 |
| LED Light(corridor) | 7 | 1 | | | | | 1 | 1 | | | | | | | | | | | | | | | | | | | 1 | 1 | 1 | 1 | | 42 | 1260 |
| LED TV and DH Cable | 55 | 1 | | | | | | | 1 | | 1 | | | | | | | | | | | | | | | | 1 | 1 | 1 | | | 275 | 8250 |

| Particulars | Rated Power (W) | Qty in use | Time | | | | | | | | | | | | | | | | | | | | | | | | Wh / day | Total Wh /day |
|---------------------------------|-----------------|------------|------|---|---|---|-----|---|---|-----|---|----|----|----|---|---|---|---|-----|-----|---|---|---|----|----|----|----------|---------------|
| | | | 1 | 2 | 3 | 4 | 5 | 6 | 7 | 8 | 9 | 10 | 11 | 12 | 1 | 2 | 3 | 4 | 5 | 6 | 7 | 8 | 9 | 10 | 11 | 12 | | |
| LED Light(room) | 5 | 1 | | | | | 1 | 1 | | | | | | | | | | | | | 1 | 1 | 1 | | | | 25 | 125 |
| LED Light(room) | 5 | 1 | | | | | 1 | 1 | | | | | | | | | | | | | 1 | 1 | 1 | | | | 25 | 125 |
| LED Light(room) | 5 | 1 | | | | | 1 | 1 | | | | | | | | | | | | | 1 | 1 | 1 | 1 | | | 30 | 150 |
| LED Light(corridor) | 7 | 1 | | | | | 1 | | | | | | | | | | | | | | 1 | 1 | 1 | | | | 28 | 140 |
| Charger | 5 | 4 | | | | | 0.5 | | | | | | | | | | | | | | | 1 | | | | | 30 | 150 |
| Radio | 5 | 1 | | | | | | 1 | | | | | | | | 1 | 1 | 1 | 1 | 1 | | | 1 | | | | 35 | 175 |
| LED TV and DH Cable | 55 | 1 | | | | | 1 | 1 | | | | | | | | | | | | | | 1 | 1 | 1 | | | 275 | 1375 |
| Laptop | 60 | 1 | | | | | | | | | | | 1 | | | | | | | | | 1 | | | | | 120 | 600 |
| Kettle | 1200 | 1 | | | | | | | | 0.2 | | | | | | | | | 0.1 | 0.1 | | | | | | | 480 | 2400 |
| Prepaid Meters | 1 | 1 | 1 | 1 | 1 | 1 | 1 | 1 | 1 | 1 | 1 | 1 | 1 | 1 | 1 | 1 | 1 | 1 | 1 | 1 | 1 | 1 | 1 | 1 | 1 | 1 | 24 | 120 |
| Package Non commercial (School) | | | | | | | | | | | | | | | | | | | | | | | | | | | | |
| LED Light(toilet) | 3 | 1 | | | | | 1 | 1 | 1 | | | | | | | | | | | | | 1 | 1 | 1 | 1 | | 21 | 21 |
| LED Light(toilet) | 3 | 1 | | | | | 1 | 1 | 1 | | | | | | | | | | | | | 1 | 1 | 1 | 1 | | 21 | 21 |
| LED Light(office) | 5 | 1 | | | | | 1 | 1 | 1 | | | | | | | | | | | | | 1 | 1 | 1 | | | 30 | 30 |
| LED Light(teacher room) | 5 | 1 | | | | | 1 | 1 | | | | | | | | | | | | | 1 | 1 | 1 | 1 | 1 | | 35 | 35 |
| LED Light(computer lab) | 5 | 1 | | | | | 1 | 1 | | | | | | | | | | | | | 1 | 1 | 1 | 1 | 1 | | 35 | 35 |
| LED Light(class room) | 5 | 1 | | | | | 1 | 1 | | | | | | | | | | | | | 1 | 1 | 1 | 1 | 1 | | 35 | 35 |
| LED Light(class room) | 5 | 1 | | | | | 1 | 1 | | | | | | | | | | | | | 1 | 1 | 1 | 1 | 1 | | 35 | 35 |
| LED Light(class room) | 5 | 1 | | | | | 1 | 1 | 1 | | | | | | | | | | | | 1 | 1 | 1 | 1 | 1 | | 40 | 40 |

| Particulars | Rated Power (W) | Qty in use | Time | | | | | | | | | | | | | | | | | | | | | | | | Wh / day | Total Wh /day | | |
|---------------------------------|-----------------|------------|------|---|---|---|-----|-----|---|-----|---|-----|-----|----|---|---|---|---|-----|---|---|---|---|----|----|----|----------|---------------|-------|----|
| | | | 1 | 2 | 3 | 4 | 5 | 6 | 7 | 8 | 9 | 10 | 11 | 12 | 1 | 2 | 3 | 4 | 5 | 6 | 7 | 8 | 9 | 10 | 11 | 12 | | | | |
| LED Light(class room) | 5 | 1 | | | | | 1 | 1 | 1 | | | | | | | | | | | 1 | 1 | 1 | 1 | 1 | | | 40 | 40 | | |
| LED Light(corridor) | 7 | 1 | 1 | 1 | 1 | 1 | 1 | 1 | | | | | | | | | | | | 1 | 1 | 1 | 1 | 1 | 1 | | 84 | 84 | | |
| Charger | 5 | 4 | | | | | | | | | | 0.5 | 0.5 | | | | | | | | | | | | 1 | | 40 | 40 | | |
| Radio | 5 | 1 | | | | | 0.5 | 0.5 | | | | | | | | | | | 0.5 | | | 1 | | | 1 | | 17.5 | 17.5 | | |
| computer | 100 | 3 | | | | | | | | | | | | | | | | | 1 | 1 | | | | 1 | | 1 | | 1200 | 1200 | |
| Kettle | 1200 | 1 | | | | | | | | 0.2 | | | | | | | | | | | | | | | 1 | | 1440 | 1440 | | |
| Prepaid Meters | 1 | 1 | 1 | 1 | 1 | 1 | 1 | 1 | 1 | 1 | 1 | 1 | 1 | 1 | 1 | 1 | 1 | 1 | 1 | 1 | 1 | 1 | 1 | 1 | 1 | 1 | 1 | 24 | 24 | |
| Package commercial(Rice mills) | | | | | | | | | | | | | | | | | | | | | | | | | | | | | | |
| LED Light(toilet) | 3 | 1 | | | | | 1 | | | | | | | | | | | | | | | | | 1 | 1 | 1 | 1 | | 15 | 15 |
| LED Light(workshop) | 7 | 1 | | | | | | 1 | 1 | | | | | | | | | | | 1 | 1 | 1 | 1 | 1 | | | | 49 | 49 | |
| LED Light(workshop) | 12 | 1 | | | | | | 1 | 1 | | | | | | | | | | | | | | 1 | 1 | 1 | 1 | | 72 | 72 | |
| radio | 5 | 1 | | | | | | 1 | 1 | | | | | | | | | | | | | | 1 | 1 | | | | 20 | 20 | |
| Charger | 5 | 2 | | | | | | | | | | 0.5 | 0.5 | | | | | | | | | | | 1 | 1 | | | 30 | 30 | |
| Rice mill | 2500 | 1 | | | | | | | | | | 1 | | 1 | 1 | 1 | | | | | | | | | | | | 10000 | 10000 | |
| Prepaid Meters | 1 | 1 | 1 | 1 | 1 | 1 | 1 | 1 | 1 | 1 | 1 | 1 | 1 | 1 | 1 | 1 | 1 | 1 | 1 | 1 | 1 | 1 | 1 | 1 | 1 | 1 | 1 | 24 | 24 | |
| Package commercial (Saw mills)) | | | | | | | | | | | | | | | | | | | | | | | | | | | | | | |
| LED Light (toilet) | 3 | 1 | | | | | 1 | | | | | | | | | | | | | | | | | 1 | 1 | 1 | 1 | | 15 | 15 |
| LED Light(battry room) | 5 | 1 | | | | | | 1 | 1 | | | | | | | | | | | | | | | 1 | 1 | 1 | 1 | | 30 | 30 |
| LED Light(office) | 5 | 1 | | | | | | 1 | 1 | | | | | | | | | | | | | | | 1 | 1 | 1 | 1 | | 30 | 30 |

ANNEX 3: VOLTAGE DROP CALCULATION

| Section | Households | Power | Number of poles | Length | Voltage | Current | Voltage drop |
|---------|------------|-------|-----------------|--------|---------|---------|--------------|
| R phase | | | | | | | |
| PA | 20 | 2900 | 11 | 0.41 | 400.00 | 4.28 | 1.83 |
| AB | 14 | 2030 | 3 | 0.08 | 398.17 | 3.01 | 0.26 |
| BC | 11 | 1595 | 11 | 0.41 | 397.91 | 2.36 | 1.01 |
| CD | 11 | 1595 | 8 | 0.29 | 396.90 | 2.37 | 0.71 |
| DE | 11 | 1595 | 6 | 0.21 | 396.19 | 2.37 | 0.51 |
| EF | 11 | 1595 | 7 | 0.25 | 395.68 | 2.38 | 0.61 |
| FG | 11 | 1595 | 5 | 0.16 | 228.36 | 7.13 | 1.22 |
| GH | 11 | 1595 | 7 | 0.25 | 227.14 | 7.17 | 1.84 |
| HI | 11 | 1595 | 7 | 0.25 | 225.30 | 7.22 | 1.86 |
| IJ | 11 | 1595 | 7 | 0.25 | 223.45 | 7.28 | 1.87 |
| JK | 11 | 1595 | 5 | 0.16 | 221.58 | 7.35 | 1.26 |
| KL | 11 | 1595 | 12 | 0.45 | 220.32 | 7.39 | 3.48 |
| L | | | | | 216.84 | | |
| Y phase | | | | | | | |
| PA | 20 | 2900 | 11 | 0.41 | 400.00 | 4.28 | 1.83 |
| AB | 20 | 2900 | 3 | 0.08 | 398.17 | 4.30 | 0.37 |
| BC | 20 | 2900 | 11 | 0.41 | 397.80 | 4.30 | 1.84 |
| CD | 11 | 1595 | 8 | 0.29 | 395.96 | 2.38 | 0.71 |
| DE | 7 | 1015 | 6 | 0.21 | 395.25 | 1.51 | 0.32 |
| EF | 4 | 580 | 7 | 0.25 | 394.92 | 0.87 | 0.22 |
| F | | | | | 228.15 | | |
| KM | | | | | | | |
| PA | 20 | 2900 | 11 | 0.41 | 400.00 | 4.28 | 1.83 |
| AB | 20 | 2900 | 3 | 0.08 | 398.17 | 4.30 | 0.37 |
| BC | 20 | 2900 | 11 | 0.41 | 397.80 | 4.30 | 1.84 |
| CD | 20 | 2900 | 8 | 0.29 | 395.96 | 4.32 | 1.29 |

| Section | Households | Power | Number of poles | Length | Voltage | Current | Voltage drop |
|---------|------------|-------|-----------------|--------|---------|---------|--------------|
| DE | 20 | 2900 | 6 | 0.21 | 394.67 | 4.33 | 0.93 |
| EF | 17 | 2465 | 7 | 0.25 | 393.74 | 3.69 | 0.95 |
| FG | 16 | 2320 | 5 | 0.16 | 227.05 | 10.43 | 1.79 |
| GH | 13 | 1885 | 7 | 0.25 | 225.26 | 8.54 | 2.19 |
| HI | 10 | 1450 | 7 | 0.25 | 223.07 | 6.63 | 1.70 |
| IJ | 6 | 870 | 7 | 0.25 | 221.36 | 4.01 | 1.03 |
| JK | 1 | 145 | 5 | 0.16 | 220.33 | 0.67 | 0.12 |
| K | | | | | 220.22 | | |

ANNEX 4: GPS LOCATIONS OF POLES AND POWERHOUSE

| S.N. | Latitude | Longitude | S.N. | Latitude | Longitude |
|------|----------|-----------|------|----------|-----------|
| 1. | 27.52263 | 87.62247 | 47 | 27.51960 | 87.62950 |
| 2. | 27.52226 | 87.62262 | 48 | 27.51935 | 87.62983 |
| 3. | 27.52265 | 87.62258 | 49 | 27.51900 | 87.62998 |
| 4. | 27.52258 | 87.62280 | 50 | 27.51888 | 87.63037 |
| 5. | 27.52267 | 87.62267 | 51 | 27.51878 | 87.63082 |
| 6. | 27.52273 | 87.62317 | 52 | 27.51847 | 87.63112 |
| 7. | 27.52302 | 87.62352 | 53 | 27.51830 | 87.63073 |
| 8. | 27.5232 | 87.62388 | 54 | 27.51800 | 87.63045 |
| 9. | 27.52337 | 87.62425 | 55 | 27.51775 | 87.63015 |
| 10. | 27.52365 | 87.62455 | 56 | 27.51767 | 87.63140 |
| 11. | 27.52383 | 87.62490 | 57 | 27.51767 | 87.62973 |
| 12. | 27.52418 | 87.62507 | 58 | 27.51733 | 87.62995 |
| 13. | 27.52453 | 87.62520 | 59 | 27.51700 | 87.63012 |
| 14. | 27.52483 | 87.62547 | 60 | 27.51660 | 87.63012 |
| 15. | 27.52523 | 87.62543 | 61 | 27.51627 | 87.62993 |
| 16. | 27.52555 | 87.62523 | 62 | 27.51588 | 87.62992 |
| 17. | 27.52555 | 87.62563 | 63 | 27.51548 | 87.62980 |
| 18. | 27.5256 | 87.62608 | 64 | 27.51512 | 87.62992 |
| 19. | 27.52523 | 87.62617 | 65 | 27.51478 | 87.63008 |
| 20. | 27.52488 | 87.62627 | 66 | 27.51442 | 87.63003 |
| 21. | 27.52457 | 87.62647 | 67 | 27.51407 | 87.62985 |
| 22. | 27.5242 | 87.62650 | 68 | 27.51385 | 87.62948 |
| 23. | 27.52393 | 87.62642 | 69 | 27.5135 | 87.62955 |
| 24. | 27.52347 | 87.62643 | 70 | 27.51315 | 87.62940 |
| 25. | 27.5231 | 87.62632 | 71 | 27.51277 | 87.62938 |
| 26. | 27.52277 | 87.62615 | 72 | 27.51240 | 87.62940 |
| 27. | 27.52238 | 87.62607 | 73 | 27.51205 | 87.62957 |
| 28. | 27.52237 | 87.62648 | 74 | 27.51182 | 87.62990 |
| 29. | 27.5226 | 87.62675 | 75 | 27.51322 | 87.63015 |
| 30. | 27.52262 | 87.62725 | 76 | 27.51165 | 87.63057 |

| | | | | | |
|-----|----------|----------|----|----------|----------|
| 31. | 27.52253 | 87.62767 | 77 | 27.51187 | 87.63090 |
| 32. | 27.52252 | 87.62810 | 78 | 27.51205 | 87.63118 |
| 33. | 27.52247 | 87.62852 | 79 | 27.51255 | 87.63127 |
| 34. | 27.52202 | 87.62660 | 80 | 27.51332 | 87.63170 |
| 35. | 27.52203 | 87.62705 | 81 | 27.51318 | 87.63200 |
| 36. | 27.52183 | 87.62740 | 82 | 27.51308 | 87.63240 |
| 37. | 27.52267 | 87.62780 | 83 | 27.51272 | 87.63277 |
| 38. | 27.52147 | 87.62815 | 84 | 27.51235 | 87.63288 |
| 39. | 27.52135 | 87.62858 | 85 | 27.51247 | 87.63278 |
| 40. | 27.52127 | 87.62898 | 86 | 27.51218 | 87.63318 |
| 41. | 27.52107 | 87.62933 | 87 | 27.51182 | 87.63347 |
| 42. | 27.52075 | 87.62955 | 88 | 27.51140 | 87.63372 |
| 43. | 27.52037 | 87.62943 | 89 | 27.51132 | 87.63412 |
| 44. | 27.52015 | 87.62910 | 90 | 27.51120 | 87.63452 |
| 45. | 27.51982 | 87.62892 | 91 | 27.51083 | 87.63472 |
| 46. | 27.51945 | 87.62912 | 92 | 27.51052 | 87.63497 |