



**TRIBHUVAN UNIVERSITY
INSTITUTE OF ENGINEERING
PULCHOWK CAMPUS**

THESIS NO: 078/MSPSE/016

**A Thesis report on
OPTIMAL SITING AND SIZING OF SSSC IN INPS USING MODIFIED SALP
SARM ALGORITHM CONSIDERING OPTIMAL REACTIVE POWER
DISPATCH PROBLEM**

**by
Priyanka Karna**

**A THESIS
SUBMITTED TO THE DEPARTMENT OF ELECTRICAL ENGINEERING
IN PARTIAL FULFILLMENT OF THE REQUIREMENT FOR THE DEGREE
OF MASTERS OF SCIENCE IN POWER SYSTEM ENGINEERING**

**DEPARTMENT OF ELECTRICAL ENGINEERING
LALITPUR, NEPAL**

JUNE 2024

COPYRIGHT

The author has agreed that the library, Department of Electrical Engineering, Pulchowk Campus, Institute of Engineering may make this report freely available for inspection. Moreover, the author has agreed that permission for extensive copying of this thesis report for scholarly purpose may be granted by the professors(s) who supervised the thesis work recorded herein or, in their absence, by the Head of the Department wherein the thesis report was done. It is understood that the recognition will be given to authors of this report and to the Department of Electrical Engineering, Pulchowk Campus, and Institute of Engineering in any Use of the material of this thesis report. Copying or publication or the other use of this report for financial gain without approval of the Department of Electrical Engineering, Pulchowk Campus, Institute of Engineering and author's written permission is prohibited.

Request for permission to copy or to make any other use of the material in this report in whole or in part should be addressed to:

Head

Department of Electrical Engineering

Central Campus, Pulchowk, Institute of Engineering

Lalitpur, Nepal



Accredited by University Grants
Commission (UGC) Nepal 2020

त्रिभुवन विश्वविद्यालय
TRIBHUVAN UNIVERSITY
इन्जिनियरिङ्ग अध्ययन संस्थान
INSTITUTE OF ENGINEERING

पुल्चोक क्याम्पस
PULCHOWK CAMPUS



5-521260
5-521611
5-522104
5-522809

पुल्चोक, ललितपुर ।
Pulchowk, Lalitpur

CERTIFICATE OF APPROVAL

The undersigned certify that they have read, and recommended to the Institute of Engineering for acceptance, a dissertation entitled "OPTIMAL SITING AND SIZING OF SSSC IN INPS USING MODIFIED SALP SWARM ALGORITHM CONSIDERING OPTIMAL REACTIVE POWER DISPATCH PROBLEM" submitted by Ms. Priyanka Karna in partial fulfillment of the requirements for the award of **Master of Science in Power System Engineering**.

Associate Prof. Jeetendra Chaudhary
Supervisor and Coordinator
M.Sc. in Power Electronics and Drives

Assistant Prof. Akhileshwar Mishra
Supervisor
Department of electrical Engineering

Associate Prof. Basanta Kumar Gautam
Program Coordinator
M.Sc. in power system Engineering

Assistant Prof. Yuba Raj Adhikari
Head
Department of electrical Engineering

Kedar Silwal
External Examiner
Director, Nepal Electricity Authority

June, 2024

ABSTRACT

In a power system, effective coordination between generation and demand is crucial. With the growing demand for electrical energy, optimizing the operation of all components to maximize efficiency becomes imperative. FACTS devices are essentially tools designed to enhance the efficiency of the transmission system. In a power system network, these devices are employed to enhance the power transfer capacity of transmission lines. Their utilization results in improved voltage stability, transient stability, voltage regulation, reliability, and increased thermal limits within the transmission network. The Static Synchronous Series Compensator (SSSC) is a method of series compensation applied in the transmission system. Its purpose is to either raise or lower the voltage drop along the line, thereby managing the power flow through the transmission line. By introducing voltage in quadrature with the line current, the SSSC regulates the power flow by controlling the equivalent impedance of the transmission line. The SSSC's output voltage is entirely controllable and operates independently of the line current. The Optimal Reactive Power Dispatch (ORPD) problem is tough because of non linear and non-convex functions. Addition of SSSC makes the solution even harder by bringing in complex dynamics for controlling power flow. To deal with these challenges, we need smart techniques and computer methods to find good solutions with efficient and reliable optimization algorithm to solve the problem of ORPD and identify the optimal location and rating of SSSC. In this thesis, Modified Salp Swarm Algorithm is used to solve the ORPD with and without the SSSC controller to minimize power losses and voltage deviations as well as improve the voltage stability on the Intergrated Nepal Power System (INPS) system and hence the result is compared with the standards IEEE 30-bus system. After solving the ORPD problem and load flow analysis, initial line losses of 119.108 MW (5.8% of total load) reduced to 35.336 MW (1.72% of total load) after including SSSC in INPS. The optimal SSSC size is 58.307 MVA, located on line Lahan to Kusaha, resulting in significant power loss reduction and voltage profile improvement.

Index: Flexible alternating current transmission systems, static synchronous series compensator, Optimal reactive power dispatch, Integrated Nepalese Power System

ACKNOWLEDGEMENT

First of all, I would like to express my deep sense of gratitude to my Supervisor Associate Professor Jeetendra Chaudhary and Assistant Professor Akhileshwar Mishra Department of Electrical Engineering for his precious and inspiring guidance, suggestions, support, and encouragement required for the successful completion of the thesis.

I would like to thank Assistant Professor Yuba Raj Adhikari, Head of Department of Electrical Engineering for his support and suggestions to complete thesis. My special thanks goes to Prof. Dr. Nava Raj Karki and Associate Professor Basanta Kumar Gautam, (Program coordinator, M.Sc. in power system Engineering), Department of Electrical Engineering for his help during the period of study. I would also like to thank the rest of faculty members of Department of Electrical Engineering, for their valuable input and time during the review of my thesis.

I would like to thank the Department of Electrical Engineering, Pulchowk Campus, for providing generous support and adequate physical facilities during the thesis work.

I am grateful to all those who have directly or indirectly contributed during the study. I would like to thank my senior and my friends for their encouragement, support and help during the research work especially, Mr. Prabhat Kumar Pankaj, Mr. Chandan Pokhrel Mr. Rupesh Kumar Sah and Mr. Gopal Kumar Yadav for their valuable suggestions and support.

Finally, I would like to express my deepest appreciation to my parents, my husband Mr Dependra Kumar Dutta, and all of my family members for their never-ending love, constant support, and encouragement.

Priyanka Karna

June, 2024

TABLE OF CONTENTS

COPYRIGHT.....	ii
ABSTRACT.....	iii
ACKNOWLEDGEMENT.....	v
TABLE OF CONTENTS.....	vi
List of Acronyms, Symbols and Abbreviations.....	ix
CHAPTER 1. INTRODUCTION.....	1
1.1 Background.....	1
1.2 Rationale of the Study.....	2
1.3 Problem Statement.....	3
1.4 Objective and Scope.....	4
1.5 Outline of Thesis.....	4
CHAPTER 2. LITERATURE REVIEW.....	6
CHAPTER 3. METHODOLOGY.....	8
3.1 Appropriate Research Paper Collection.....	8
3.2 Data Collection and Software.....	8
3.3 Load flow analysis.....	8
3.4 SSSC Modeling and Formulation.....	10
3.5 Optimal Reactive Power Dispatch (ORPD) Problem Formulation for Different ..	12
3.5.1 Minimization of Objective Functions.....	13
3.5.2 Limitation.....	14
3.6 The Modified Salp Swarm Algorithm (MSSA).....	14
CHAPTER 4. RESULTS AND DISCUSSION.....	21
CHAPTER 5. CONCLUSION.....	27
ANNEXURE 28	
Annex 1: Load Flow Anaylsis and Optimization without Inclusion of SSSC in INPS	
28	
Annex 2: Load Flow Anaylsis and Optimization with Inclusion of SSSC in INPS	38
Annex 3: Load Flow Anaylsis and Optimization without Inclusion of SSSC in	
Standard IEEE 30-Bus System.....	49

Annex 4: Load Flow Analysis and Optimization with Inclusion of SSSC in Standard IEEE 30-Bus System.....	64
REFERENCES	78

List of Figures

Figure 3.1 Schematic diagram of SSSC.....	10
Figure 3.2 Usually Modeled SSSC Device.....	11
Figure 3.3: summing impedances in the SSSC equivalent branch	11
Figure 3.4: SSSC equivalent branch, Norton equivalent	11
Figure 3.5: SSSC equivalent nodal power injections at ends of line of insertion.....	12
Figure 3.6: MSSA Flow Chart for Resolving ORPD Issue with Ideal SSSC Integration	19
Figure 3.7: Integrated Neplese Power System.....	20
Figure 4.1: Optimizing MSSA Converging Performance to Reduce Power Losses on INPS without including the SSSC	21
Figure 4.2: Voltage Profile without Inclusion the SSSC on INPS	22
Figure 4.3: Optimizing MSSA Converging Performance to Reduce Power Losses on INPS with including the SSSC	22
Figure 4.4: Voltage Profile with Inclusion the SSSC on INPS.....	23
Figure 4.5: Optimizing MSSA Converging Performance to Reduce Power Losses on IEEE 30-Bus System without including the SSSC	24
Figure 4.6: Voltage Profile on IEEE 30-Bus System without including SSSC.....	25
Figure 4.7: Optimizing MSSA Converging Performance to Reduce Power Losses on IEEE 30-Bus System with including the SSSC	25
Figure 4.8: Voltage Profile on IEEE 30-Bus System with including SSSC.....	26

List of Acronyms, Symbols and Abbreviations

FACTS	Flexible Alternating Current Transmission Systems
INPS	Integrated Nepal Power System
KV	Kilo Volt
LFD	Levy Flight Distribution
MSSA	Modified Salp Swarm Algorithm
MW	Mega Watt
MWH	Mega Watthour
NEA	Nepal Electricity Authority
NFL	No-Free-Lunch
ORPD	Optimal reactive power dispatch
SSA	Salp Swarm Algorithm
SSSC	Static Synchronous Series Compensator
yr.	Year

CHAPTER 1. INTRODUCTION

1.1 Background

Flexible Alternating Current Transmission Systems (FACTS) are devices used within the System of Electrical Power to improve the electrical grid's controllability and stability. FACTS devices enhance voltage control, power flow management, and system stability by adjusting AC transmission system parameters. These adjustments, which include bus voltage, the impedance of the transmission line and their active power flow and reactive power flow, make FACTS devices the pinnacle of technological advancements in system performance. Among these devices, Static Synchronous Series Compensator which is SSSC stands out as one of the best tools for achieving optimal reactive power dispatch in power systems. Composed of a transformer connected to a solid-state a voltage source inverter, the SSSC is intended to regulate and ensure the power system's dependable operation. By introducing a variable voltage in series with the transmission line, this device aims to regulate and control the flow of both reactive and active power throughout the lines. Overall power system efficiency and stability are improved by this function. SSSC provides fast and accurate voltage control capabilities. It has the ability to control the phase angle and voltage magnitude, allowing for better voltage stability and control during variations in system conditions. SSSC can inject or absorb reactive power into the system as needed. By adjusting the reactive power flow, SSSC helps maintain the desired power factor and improves the voltage profile of the system. SSSC can increase the transmission capacity of existing transmission lines. By controlling the reactance of the transmission line, it can mitigate the voltage drop and power losses, thereby allowing more power to be transferred through the line. Compared to other FACTS devices, SSSC is relatively cost-effective in terms of installation and maintenance. It provides multiple functionalities and benefits, making it an attractive option for power system operators and planners.

Optimal reactive power dispatch (ORPD) refers to the determination of the optimal settings reactive power sources such as generators, transformers, and capacitors to maintain system voltage levels within acceptable limits and minimize losses.

The optimal reactive power dispatch problem typically aims to achieve two main objectives: ensuring voltage stability and minimizing power losses The voltage stability

objective involves keeping the system voltages within specified limits to ensure proper functioning of electrical equipment and to prevent voltage collapse. The power loss minimization objective aims to reduce the losses in the transmission and distribution systems, which can improve the overall efficiency of the grid.

The problem for dispatch of optimal reactive power remains a field of study that is ongoing. This is largely because power systems are becoming increasingly complex with the addition of renewable energy sources, flexible loads, and advanced control technologies. Researchers continue to develop new algorithms and optimization techniques to address the challenges posed by modern power systems and to improve the efficiency, reliability, and sustainability of electrical grids. In order to address the ORPD problem and determine the most suitable location and ratings for the SSSC, an efficient and reliable optimization algorithm has been used expressly for this thesis. The Modified Salp Swarm Algorithm (MSSA) is the algorithm chosen for its ability to handle complex optimization challenges within power systems. MSSA can be applied to address various challenges in power systems, including optimal power flow, economic dispatch, and network reconfiguration. In the case of Optimal Power Flow, MSSA is utilized to optimize the operating conditions of a power system by adjusting control variables such as generator setpoints, transformer tap positions, and reactive power sources. The algorithm converges over iterations, ideally reaching a solution that optimizes the specified objective function for the power system operation. A voltage profile is improved and power losses are reduced by solving the ORPD both with and without an SSSC controller. The algorithm used for ORPD is tested on the INPS and compared with the results of standards IEEE 30-bus system. Integrating the SSSC into the system's design strategically enhances its overall performance, improving stability and efficiency. This makes the SSSC an essential component in modern power grid management strategies.

1.2 Rationale of the Study.

With the increasing complexity and demand in power systems, there is a growing need for smart grid technologies to enhance efficiency, reliability, and sustainability. The power grid becomes more unpredictable and variable as a result of the incorporation of renewable energy sources like wind and solar power. Static Synchronous Series Compensator i.e. SSSC is a device used to enhance the power system's capacity for

power transfer and transient stability. One crucial component of power system operation is the Dispatch Problem of Optimal Reactive Power. It involves determining the most suitable settings for reactive power devices to minimize system losses and enhance voltage stability. SSSC is a flexible and effective device for power system control, but its optimal siting and sizing are crucial for achieving maximum benefit. The optimal size and location of SSSC can significantly impact the overall performance of the power system. The complexity of determining the optimal location and size of SSSC, especially when considering the Optimal Reactive Power Dispatch Problem, requires advanced optimization techniques. The Modified Salp Swarm Algorithm is one such metaheuristic optimization algorithm known for its effectiveness in solving complex optimization problems. There might be gaps in the existing literature regarding the integration of SSSC, reactive power dispatch, and the use of Modified Salp Swarm Algorithm. This study aims to fill that gap by providing a comprehensive approach to optimize the siting and sizing of SSSC in an Integrated Nepalese Power System (INPS) while considering reactive power dispatch problem. This thesis addresses the challenges posed by the effectiveness of SSSC in the the INPS system using advanced optimization techniques like the Modified Salp Swarm Algorithm. The study contributes to the ongoing efforts to make power systems more reliable, efficient, and capable of accommodating renewable energy sources.

1.3 Problem Statement

INPS faces the problem of voltage stability of both kinds i.e., over voltage and under voltage even in wet season too when there is surplus power in the network. The problem entails determining the most suitable location and the SSSC device size in INPS, considering the system's characteristics, load demand, and network topology. Additionally, the optimal reactive power dispatch, which is the allocation of reactive power resources must be considered to reduce losses in power and maintain stability of voltage.

The proposed research will investigate how the MSSA can be modified and enhanced to handle the complexities associated with the optimal siting and sizing of SSSC, considering the optimal reactive power dispatch. The key challenges to be addressed include developing suitable objective functions that capture both power loss minimization and voltage stability, incorporating system constraints, and optimizing

multiple variables simultaneously. By successfully addressing these challenges, the research aims to provide power system operators and planners with an efficient and accurate tool for determining the optimal size and location within an INPS of SSSC devices. This will lead to improved system performance, enhanced voltage profile and less power losses, and overall grid reliability.

1.4 Objective and Scope

The main objective of this research is to address the challenge of utilizing a Modified Slap Swarm Algorithm (MSSA) to find the best location and size for SSSCs in an INPS while taking dispatch of optimal reactive power into account. The most suitable location is identified in the INPS grid for installing SSSC devices considering factors such as line loading, voltage stability, and system performance indices. The appropriate capacity or rating of the SSSC devices is determined which has to be installed at the identified locations. The sizing should be optimized based on various criteria, such as minimizing power losses, enhancing the voltage profile and optimizing the system's capacity to handle load.

By achieving these objectives, the research aims to provide power system planners and operators with a reliable and effective methodology for determining the most suitable location and size for SSSC devices in INPS. The proposed approach can help improve the overall system performance, enhance stability, and minimize power losses, thereby contributing to the efficient operation of the power grid.

The main scope of this thesis is given below:

- Minimization of power losses
- Reduced system losses
- Improved voltage profile

1.5 Outline of Thesis

Creating an outline of this thesis work, involves structuring the content in logical and organized manner which is given below:

Chapter 1 provides the introduction part and has the component which explains the general overview and background, explaining the reasons for the study, stating the problem, listing the study's goals, and defining its scope.

Chapter 2 provides a modelling of SSSC and its previous studies on SSSC Siting and Sizing, Optimization Techniques for Reactive Power Dispatch and challenges and Gaps in the Literature

In Chapter 3, the methodology includes the formulation of the optimal SSSC siting and sizing problem, modelling of SSSC and integration with the Optimal Reactive Power Dispatch Problem. Data collection of the INPS and coding done for the load flow analysis and integrated with SSSC.

Chapter 4 provides an interpretation of results, implications of Optimal SSSC Siting and sizing in INPS system and compares with the result of IEEE 30 Bus system.

In conclusion, Chapter 5 provides summary of key findings contributions to existing knowledge.

CHAPTER 2. LITERATURE REVIEW

A number of technologies have been developed and incorporated to electrical systems in order to enhance their performance. One of the most often used technologies in power systems is FACTS, which regulates several different parameters including transmission line impedance, active power, reactive power, and bus voltage magnitude. FACTS devices therefore significantly improve power systems' stability and security. The SSSC controller is an essential part of the FACTS technology and is arranged in series along transmission lines. The placement of this device allows for efficient management of the flow of both reactive and active power, which improves the stability and efficiency of power transmission networks while providing accurate control [1]. The SSSC increases the operational flexibility and efficiency of the system by directly injecting an AC voltage into the transmission line that is precisely regulated in terms of both amplitude and phase angle. In paper [2] it has been proposed a method for modeling the of SSSC within the load flow analysis by representing it as injection of power at the nodes the line where the installation is made. The energy introduced by the SSSC into the system serves as pivotal input for performing precise power flow calculations. The dispatch problem of optimal reactive power intends to reduce the entire system losses while satisfying the operational constraints of a power system. Reactive power dispatch refers to the control of reactive power sources such as generators, capacitors, and transformers to maintain voltage stability and minimize system losses. The ORPD problem has been approached using a variety of conventional methods, including linear and non-linear programming, interior point methods, and quadratic programming [3]. The challenge of managing non-convex or nonlinear fitness functions is a major drawback of traditional methods. Moreover, these techniques can find themselves stuck in local objective function minima. To address these optimization issues, a number of meta-heuristic optimization strategies have surfaced recently [4]. These methods have been demonstrated not only to address the primary limitations of conventional approaches but also to be highly effective in solving the ORPD issue. Genetic algorithms (GA) and particle swarm optimization (PSO) are two examples. [5], the grey wolf optimization [8], the ant colony algorithm (ACA), the gravitational search algorithm (GSA), the whale optimization algorithm (WOA) [6], the lightning attachment process optimization [7], and the traditional salp swarm algorithm [9].

In order to overcome the ORPD problem and integrate SSSC into the IEEE-30 bus system, a number of researchers have used various algorithms with the goal of improving voltage profiles and overall voltage stability. Testing on the IEEE 30-bus standard have been conducted using the ORPD algorithm. Simulation results indicate that MSSA is more efficient and performs better than other meta-heuristic methods that have been reported for ORPD solution [10]. Inspired by the behavior of salps, which are sea invertebrates, the Salp Swarm Algorithm i.e. SSA is a novel optimization methodology. It was presented by Mirjalili in 2017 as a revolutionary approach for addressing challenging optimization issues. The Salp Swarm Algorithm is a relatively simple and efficient optimization method that has been effectively used to various real-world problems, including engineering design, data clustering, and feature selection, among others [11]. However, as with any optimization algorithm, its performance may vary depending on the problem being solved and the tuning of its parameters. Mathematical model has been proposed in [12] in order to resolve the optimization issue.

CHAPTER 3.METHODOLOGY

This thesis' primary goal is to use the Modified Salp Swarm Algorithm to determine the ideal SSSC location and size within the INPS. Using the Optimal Reactive Power Dispatch solution, an SSSC model is created to maximize power losses and voltage deviation reduction. Load flow analysis is carried out in INPS without SSSC and with SSSC and result is compared with the IEEE 30-Bus system.

3.1 Appropriate Research Paper Collection

At the beginning of the thesis project collection of relevant information was carried out researching topics like modelling of SSSC, Optimal Reactive Power Dispatch techniques with algorithms and gone through various sources to understand these topics well. This detailed investigation was done to lay the foundation for future research and to find appropriate software tools for the study.

3.2 Data Collection and Software

Information is gathered on the INPS, including load demand, generation capacity, and network topology. Additionally, transmission line information and other pertinent characteristics are acquired. The Load Dispatch Center and other pertinent NEA divisions provide the most recent information on the voltages, generation capacity, and load demands. MATLAB was chosen as the suitable software for the task due to its ability to perform various calculations such as Load Flow analysis, Power Loss calculation, and Optimization. The MATLAB programming language was utilized to support the coding necessary for the thesis.

3.3 Load flow analysis

In order to evaluate and manage a power system, load flow analysis is vital. It is the basis for power system analysis and is essential to the planning and development of transmission and generation infrastructure. In short, load flow analysis entails figuring out unknown bus voltages, uncertain generation levels, and the complicated power flow between network components in a given power system. It incorporates known loads with specified power generation and voltage constraints. Usually, the analysis also includes

determining losses within individual components and throughout the network, as well as assessing for potential overloads and voltage deviations that exceed acceptable limits. Load flow analysis is a fundamental aspect of power system engineering, essential for predicting and managing electrical flows to maintain stability and efficiency. Among the methodologies used, the Newton-Raphson method is widely preferred due to its robustness in handling complex power networks.

Before applying the Newton-Raphson method, it's crucial to establish the network's impedance parameters (Y-BUS or Z-BUS matrix), which define the electrical connections between buses and branches. These parameters are pivotal for accurately simulating the dynamics of power flow within the network.

Buses in a power network serve distinct purposes and are categorized based on available data:

Swing bus: Typically associated with a generator, this bus has a specified voltage magnitude and phase angle, serving as a reference point in the analysis.

Generator (PV) bus: These buses connect generators and have known values for voltage magnitude and real power output. During analysis, reactive power output and phase angle are computed to maintain power balance.

Load (PQ) bus: Connecting various loads, these buses have known values for real and reactive power consumption. The analysis calculates voltage magnitude and phase angle to ensure the network meets electrical demand requirements.

The Newton-Raphson method iteratively solves nonlinear algebraic equations derived from power flow equations. This iterative process adjusts voltage magnitudes and phase angles at each bus until convergence criteria are satisfied, providing a stable solution that accurately reflects the network's operational state under steady conditions.

By utilizing the Newton-Raphson method, engineers can effectively analyze and optimize power network performance. This approach is indispensable for operational planning, ensuring reliable electricity delivery while accommodating operational constraints and unforeseen contingencies in modern power system engineering.

The Newton-Raphson and Gauss-Seidel algorithms are the two main load flow calculation techniques available in MATLAB programming. The system design, the generator's characteristics, the load levels, and the starting bus voltage conditions all influence which of these approaches is better. The Newton Raphson method is applied in this study.

3.4 SSSC Modeling and Formulation

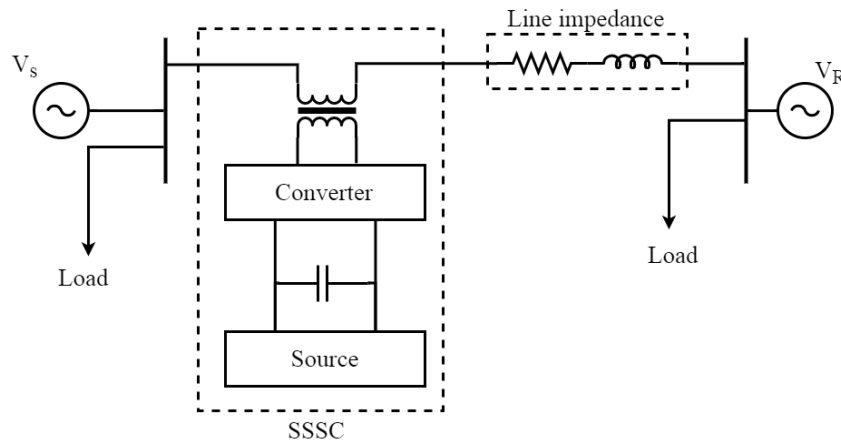

Figure 3.1 Schematic diagram of SSSC

Modeling of the SSSC is carried out in the load flow analysis of an electrical power system. Load flow analysis is a fundamental calculation in power systems that evaluates the steady-state operating conditions. The SSSC device is modeled as power injections at the transmission line nodes where it is located instead of being directly incorporated into the load flow calculations. These power injections show how the SSSC affects the flow of power. The SSSC is represented by the power injections, which are used as inputs in the load flow computation. This initial load flow calculation is performed without considering the presence of the SSSC. The results from the load flow calculation without the SSSC yield a mismatch vector, which indicates the deviation from the desired conditions. This mismatch vector includes requirements related to the SSSC. In order to minimize this mismatch vector, the power injections that represent the SSSC are then modified and updated. Next, using the updated power injections that represent the SSSC, the load flow computation is resumed. This process is repeated iteratively. Convergence is achieved when, after a load flow calculation, the mismatch vector becomes sufficiently small. This implies that the system has reached a steady-state condition that satisfies the requirements imposed by the SSSC. Hence, SSSC is

indirectly introduced into the load flow analysis, and an iterative process is employed to adjust its representation until the power system converges to a solution that meets the specified SSSC requirements.

The SSSC device is equivalent to a voltage source that is coupled in series with the impedance of the SSSC.

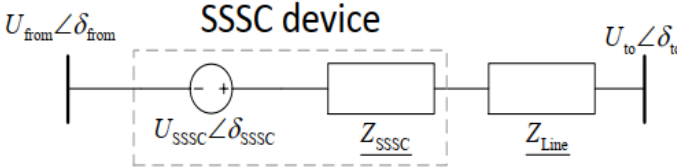

Figure 3.2 Usually Modeled SSSC Device

This can be converted directly to:

$$Z_{Total} = Z_{SSSC} + Z_{Line} \tag{1}$$

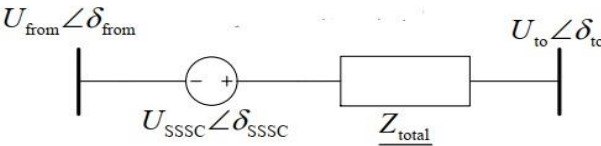

Figure 3.3: summing impedances in the SSSC equivalent branch

The Norton equivalent, figure 3.3 it has been obtained:

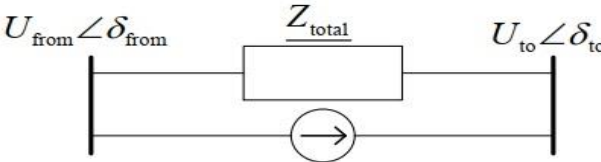

Figure 3.4: SSSC equivalent branch, Norton equivalent

$$I_G = \frac{U_{SSSC} \angle \delta_{SSSC}}{Z_{total}} \tag{2}$$

The initial approach can be rephrased with a focus on power injections in the following ways:

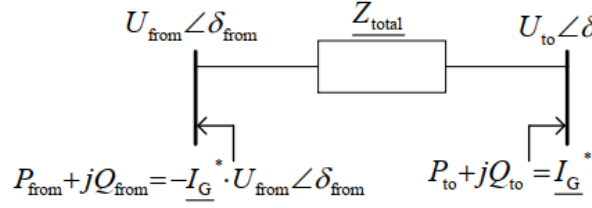

Figure 3.5: SSSC equivalent nodal power injections at ends of line of insertion

$$P_{from} + jQ_{from} = -I_G^* \cdot U_{from} \angle \delta_{from} \quad (3)$$

$$P_{to} + jQ_{to} = I_G^* \cdot U_{to} \angle \delta_{to} \quad (4)$$

The power injections will model an SSSC device. The parameters of the SSSC device, U_{SSSC} and δ_{SSSC} , can then be calculated from the injected powers and the voltages and angles at the bus of SSSC device as:

$$U_{SSSC} \angle \delta_{SSSC} = Z_{total} \cdot I_G \quad (5)$$

The Power Injection Model allows for effective modeling of the SSSC. It is essential to represent the SSSC as a voltage source within this model, a condition that is satisfied according to the provided figure 3.4, if the SSSC device is modelled as an equivalent current source, it means that the device injects a current into the transmission line, and the injected currents at both nodes (terminals) of the SSSC need to be equal. To fully define the SSSC model, we use Figure 3.5 for reference. By equating the real and imaginary parts of the injected current at the "from" bus to those at the "to" bus, and deriving two additional equations, we establish a comprehensive set of equations that accurately characterize the SSSC model.

3.5 Optimal Reactive Power Dispatch (ORPD) Problem Formulation for Different Objective Functions

The aim of the ORPD problem is to find the values of control variables that minimize the objective function while satisfying certain equality and inequality conditions. The control variables include various parameters that can be adjusted, such as generator power and bus voltages. The dependent variables are the outcomes or results of the optimization, representing aspects like power generation, bus voltages, and the impact of the SSSC. The formulation of these equations are from the reference [10].

3.5.1 Minimization of Objective Functions

In general, the dispatch problem optimal reactive power of objective function is defined as follows:

$$\text{Minf}(x) \quad (6)$$

With respect to

$$g_j(x, u) = 0 \quad j= 1,2, \dots, m \quad (7)$$

$$h_j(x, u) \leq 0 \quad j= 1,2, \dots, p \quad (8)$$

As the objective function, let F stand for. The dependent and independent control variables are denoted by x and u , respectively. The equality and inequality constraints are represented by g_j and h_j , respectively, while the number of equality and inequality constraints is indicated by m and p .

The following is a representation of the independent variables:

$$U = [P_{g2} \dots P_{gng}, V_{g1} \dots V_{gng}, Q_{c1} \dots Q_{cnc}, T_1 \dots T_{nt}, P_{sp}, Q_{sp}, L_c] \quad (9)$$

The power generated at the slack bus, the voltage levels at PQ buses, the reactive power generated by generators, transmission line power flows, and the voltage injected by the SSSC, both in terms of magnitude and phase angle, are all considered dependent variables which are as follows:

$$X = [P_{g1}, V_{l1} \dots V_{lnpq}, Q_{g1} \dots Q_{gng}, S_{tl1} \dots S_{tntl}, |V_{se}|, \theta_{se}] \quad (10)$$

Power Losses Minimization and Voltage Deviations

In a single objective function, the reduction of active power losses and voltage variations can be stated as follows:

$$F = \alpha \sum_{i=1}^{NL} P_{losses} + \beta \sum_{i=1}^{NL} [V_i - V_{ref}] \quad (11)$$

Here, F denotes the objective function, where α and β are weighting factors representing the relative importance of power losses minimization and voltage deviations, respectively. NL denotes the number of transmission lines, P_{losses} represents active power losses, V_i represents the voltage magnitude at bus i , and V_{ref} is the reference voltage, commonly set to 1.

This objective function integrates the goals of reducing both power losses and voltage deviations, allowing for a unified optimization approach that balances both objectives according to the specified weighting factors.

3.5.2 Limitation

A. Limitation on Equality

The equations for balanced load flow in these limitations are expressed as follows:

$$P_{Gi} - P_{Di} = \sum_{j=1}^{NB} |V_i| |V_j| |Y_{ij}| \cos(\theta_{ij} - \delta_{ij}) \quad (12)$$

$$Q_{Gi} - Q_{Di} = \sum_{j=1}^{NB} |V_i| |V_j| |Y_{ij}| \sin(\theta_{ij} - \delta_{ij}) \quad (13)$$

B. Limitation on Inequality

These limitations, which display the operational bounds of the system component, include:

$$P_{Gi}^{min} \leq P_{Gi} \leq P_{Gi}^{max} \quad i=1,2, \dots, NG \quad (14)$$

$$V_{Gi}^{min} \leq V_{Gi} \leq V_{Gi}^{max} \quad i=1,2, \dots, NG \quad (15)$$

$$Q_{Gi}^{min} \leq Q_{Gi} \leq Q_{Gi}^{max} \quad i=1,2, \dots, NG \quad (16)$$

$$V_{Li}^{min} \leq V_{Li} \leq V_{Li}^{max} \quad i=1,2, \dots, NPQ \quad (17)$$

$$V_{se}^{max} \leq V_{se} \leq V_{se}^{min} \quad (18)$$

$$\theta_{se}^{max} \leq \theta_{se} \leq \theta_{se}^{min} \quad (19)$$

By using penalty factors connected to these limitations, the objective function takes system constraints into account. Thus, the following is an expression for the objective function:

$$\begin{aligned} F_g(x, u) = & F_i(x, u) + eG (P_{G1} - P_{G1}^{lim})^2 + eQ \sum_{i=1}^{NPV} (Q_{Gi} - Q_{Gi}^{lim})^2 + \\ & ev \sum_{i=1}^{NPQ} (V_{Li} - V_{Li}^{lim})^2 + es \sum_{i=1}^{NLT} (S_{Li} - S_{Li}^{lim})^2 + \\ & eF (V_{se} - V_{se}^{lim})^2 + et (\theta_{se} - \theta_{se}^{lim})^2 \end{aligned} \quad (20)$$

3.6 The Modified Salp Swarm Algorithm (MSSA)

In recent years, meta-heuristic techniques have seen a significant rise in popularity, largely owing to their flexibility, gradient-free nature, and ability to circumvent local optima in optimization problems. These advantages stem from the fact that meta-heuristics approach and address optimization challenges by focusing solely on input and output parameters. Consequently, there is no requirement for calculating

derivatives within the search space, rendering them highly adaptable for tackling a wide array of problems. Meta-heuristics are a type of problems solving method that uses randomness to avoid getting stuck in only one solution. This is helpful in real-life situations where there are many possible solutions to choose from. Thanks to these strengths, meta-heuristic techniques find applications across various domains in both scientific research and industrial settings.

Evolutionary algorithms and swarm intelligence techniques are the two primary kinds of meta-heuristic algorithms. The Genetic Algorithm (GA) is a prominent example of an evolutionary algorithm that draws inspiration from natural evolutionary processes. In particular, GA models ideas from Darwinian evolutionary theory. These techniques in swarm intelligence are influenced by the coordinated behaviors seen in natural swarms, herds, schools, or flocks of animals, utilizing the collective actions and interactions found in groups of creatures. For example, ants can ensure a colony's survival without any central control. No individual ant directs others on where to find food, yet they effectively locate food sources even far from their nests. Particle Swarm Optimization (PSO), Ant Colony Optimization (ACO), and other well-known methods fall under this group.

Despite their differences, the objective of optimizing solutions is shared by swarm intelligence and evolutionary approaches. Selection, crossover, and mutation are all included in evolutionary algorithms, which replicate biological evolution. For decentralized optimization, swarm intelligence imitates organic group dynamics. Algorithms that focus on improving a single solution are termed as individualist algorithms. On the other hand, those that aim to enhance a set of solutions are known as collective algorithms. Individualist algorithms are advantageous due to their simplicity and low requirement for function evaluations. However, they often have issues with getting stuck in local optima. While usually requiring more function evaluations, collective algorithms, on the other hand, are skilled at avoiding local solutions by exchanging information across the search space. Tabu Searching, climbing hills, Iterated Local Search, Simulated Annealing, Variable Neighborhood Search, and Guided Local Search are a few examples of individualist algorithms. Popular collective algorithms include Differential Evolution, Particle Swarm Optimization, Ant Colony Optimization, Genetic Algorithms, and Evolutionary Strategies.

Despite the strengths of these algorithms, the No-Free-Lunch (NFL) theorem demonstrates that no single algorithm can excel at solving all optimization problems.

The NFL theorem is a concept in optimization theory that highlights the limitations of universal optimization algorithms. The theory states that there isn't a single optimization technique that works best for any sort of problem. A specific approach or algorithm may be required for each challenge in order to produce the best results. In simple terms, optimization is a topic without a one-size-fits-all answer. In simpler terms, all meta-heuristic algorithms generally perform similarly across different optimization problems. This highlights the importance of developing new and specialized algorithms tailored to specific fields. An example of this approach is the Salp Swarm Algorithm (SSA), initially designed for single-objective optimization and later adapted to handle multi-objective scenarios.

A. Mathematical Model of MSSA

Salps have a wondering behavior that is important to this algorithm: they tend to cluster together. Salps often form groupings called salp chains in deep ocean waters. It is not exactly sure that why they do this, but some scientists think it helps them move better by working together quickly and in sync, maybe making it easier for them to find food. In the population has been divided into two primary groups in the mathematical model of salp chains: leaders and followers. The other salps follow the leader salp, who guides the swarm at the head of the chain. As the swarm moves as one, these followers connect to the leader and to each other, in a direct or indirect manner.

Salps are positioned inside an n -dimensional search space, where n is the number of variables in a particular problem, just as other swarm-based algorithms. The locations for each salp are therefore contained in a matrix with two dimensions called Z_n .

The following solution is recommended to change the leader's location:

$$Z_n^i = \begin{cases} Z_{LD} + c_1(u_n - l_n)c_2 + l_n & c_3 \geq 0 \\ Z_{LD} + c_1(u_n - l_n)c_2 + l_n & c_3 < 0 \end{cases} \quad (21)$$

where Z_{LD} represents the food source position and Z_n^i for the leader position, respectively. In the n th dimension of the search space, the upper and lower bounds are U_n and l_n .

$$C_1 = 2e^{-\left(\frac{4a}{A}\right)} \quad (22)$$

The following expression is used to change followers' positions.

$$Z_n^m = \frac{1}{2}ce^{2+voe} \quad (23)$$

Where, $m \geq 2$, $c = \frac{v_{final}}{v_0}$ and $v = \frac{z - z_0}{e}$. The number of iterations determines the duration the simulation takes. Equation (26) illustrates this case, assuming $v_0 = 0$, where the conflict for each cycle is set to 1.

$$Z_n^m = \frac{1}{2} (z_n^m + z_n^{m-1}) \quad (24)$$

The MSSA addresses drawbacks found in the conventional SSA, such as susceptibility to periodic stagnation and local optimal conditions. Two methods to improve the SSA's performance are presented. Levy flight distribution i.e. LFD is one approach that is used. to update the positions of salps, promoting exploration and facilitating the discovery of novel approaches to address stagnation. To improve exploitation, the second approach moves salps in a spiral pattern around the optimal solution. To be more precise, the first approach that results in the use of the LFD is stated as below.

$$z_{n_new}^m = z_n^m + \alpha + \text{Levy}(\beta) \quad (25)$$

In this case, the parameter " α " denotes a step size that has the following assign.

$$\alpha + \text{Levy}(\beta) \sim 0.01 \frac{u}{|v|^{1/\beta}} (z_n^m - Z_{LD}) \quad (26)$$

where (30) and (31) are used to determine u and v in the following manner:

$$u \sim N(0, \phi_u^2), v \sim N(0, \phi_v^2) \quad (27)$$

$$\phi_u = \left[\frac{\Gamma(1+\beta) x \sin(\pi x \beta / 2)}{\Gamma[\frac{1+\beta}{2}] x^\beta} \right]^{1/\beta}, \phi_v = 1 \quad (28)$$

The second adjustment is to move salps in a spiral pattern around the optimal solution. To express this adjustment, one uses the usual gamma function, Γ .

$$Z_{n_new}^m = |Z_{LD} - Z_n^m| e^{bt} \cos(2\pi t) + z_n^m \quad (29)$$

where the logarithmic spiral shape is described by a constant, b. In order to accomplish this goal, an adaptive operator k is used to achieve a balance between both exploitation and exploration processes.

$$K(t) = k_{min} + \left(\frac{k_{max} - k_{min}}{T_{max}} \right) \times t \quad (30)$$

The upper and lower bounds of k are denoted by kmax and kmin in this case. It is noteworthy that focusing on exploration through the LFD, applied by Eq. (22) in the early iterations when k is small, increases the effectiveness of the MSSA search. On the other hand, when k is big, later iterations utilizing Eq. (27) to switch to variable bandwidth increase the exploitation phase.

B. MSSA Flow Chart for Resolving ORPD Issue with Ideal SSSC Integration

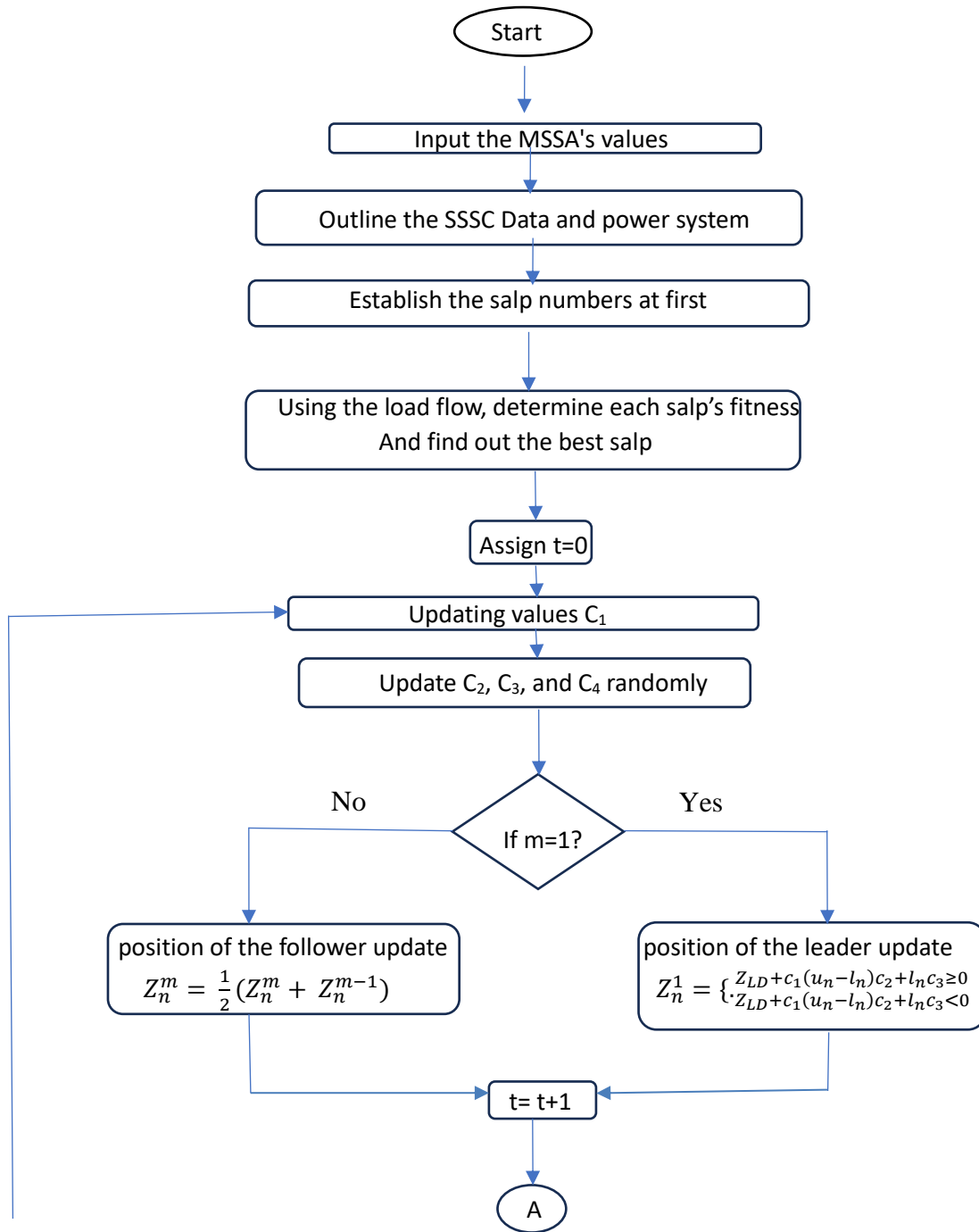

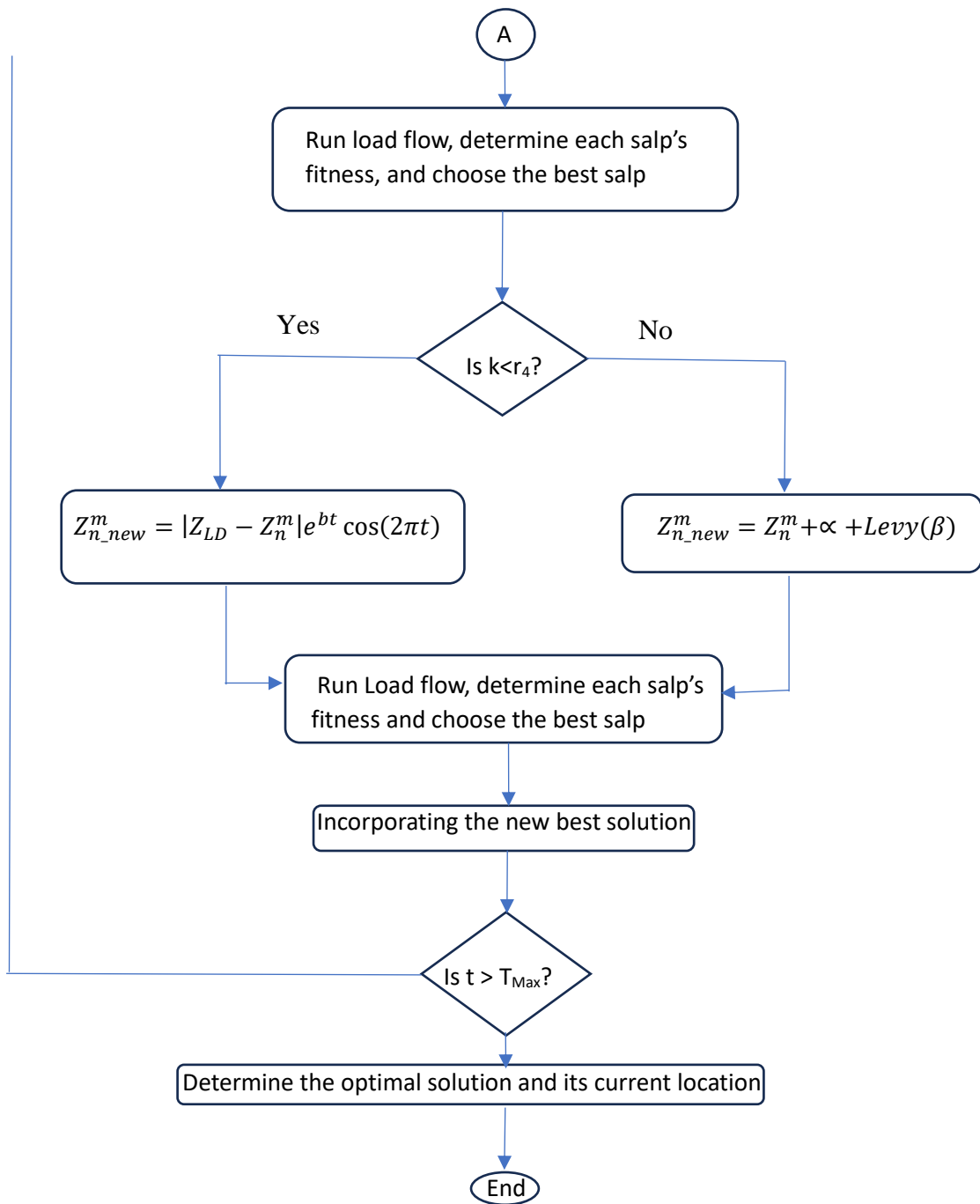

Figure 3.6: MSSA Flow Chart for Resolving ORPD Issue with Ideal SSSC Integration

Hence, the MSSA outlined in this flowchart presents a novel approach to optimizing power systems, leveraging the collective behavior of salp populations. By iteratively updating the positions of salps based on fitness evaluations and incorporating randomness to maintain diversity, the algorithm aims to find optimal solutions for power system operation.

3.7 The Single Line Diagram of Integrated Nepalese Power System

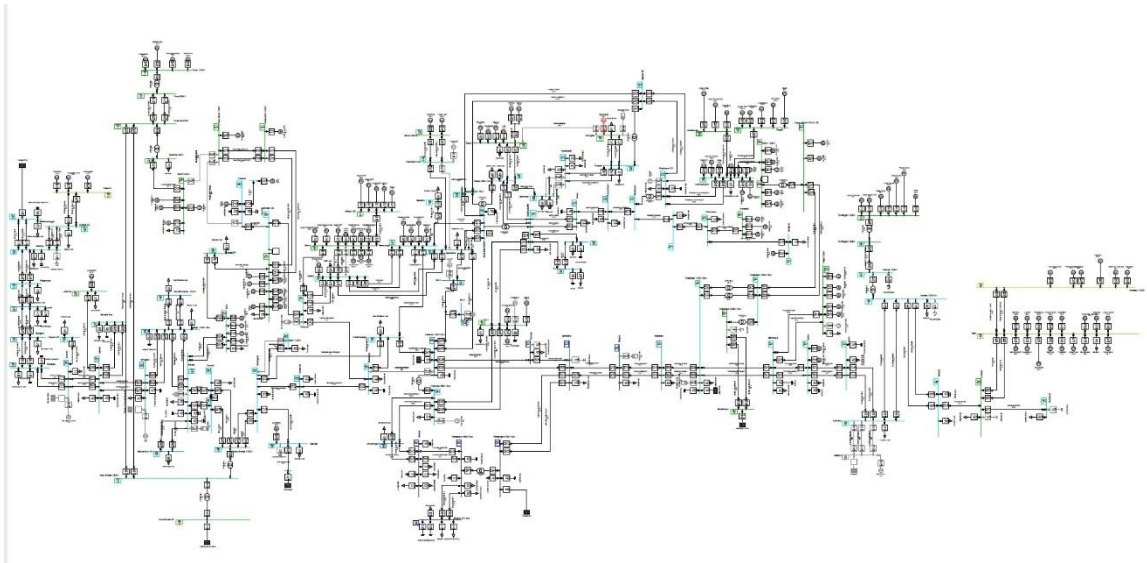

Figure 3.7: Integrated Nepalese Power System

The Integrated Nepal Power System (INPS) is the primary electrical grid network that connects power generation facilities, transmission lines, substations, and distribution networks across Nepal into a unified system. It serves as the backbone of the country's electricity infrastructure, facilitating the transmission and distribution of power from various sources to consumers throughout Nepal. INPS has 400 kV, 220 kV, 132 kV, 66 kV, 33 kV and 11 kV transmission network in which 132 kV network has mostly used in transmission network in all over Nepal. In INPS Dhalkebar and Muzaffarpur are the maximum capacity substation which has 400 kV double circuit line having highest transmission capacity. The total installed capacity in INPS is 3226 MW but the peak load is 2010 MW. In dry season generation does not meet the demand so power is imported from Indian grid through Dhalkebar and Muzaffarpur line but in wet season power is surplus so it is exported to India. Nepal has Marsyandi, Middle Marsyangdi, Kaligandaki and Chameliya as highest capacity PROR. Kulekhani-I, Kulekhani-II and Kulekhani-III and only storage type of plant in all over Nepal. Mostly generation are in hilly region and load are mostly in terai region due to which their congestion in transmitting the line and disturbance in voltage in the line.

CHAPTER 4. RESULTS AND DISCUSSION

To achieve the objective, coding was done in MATLAB programming for the INPS. ORPD problem was solved and load flow analysis was done using MSSA algorithm. Coding for Optimal placement of SSSC was done with the optimal calculation of optimal size and placement of SSSC. The line losses were calculated and was found to be 35.336(1.72% of total load) MW after the inclusion of SSSC in INPS which is very less than the loss without SSSC in INPS which was 119.108 MW ((5.8% of total load). The optimal size of SSSC was 58.307 MVA with the optimal location in line Lahan to Kusaha. The line from the Bus Lahan to the Bus Kusaha is most overloaded line in INPS.

These are the figures of MSSA convergence performance for power losses and voltage profile with base case and optimized case in INPS system with and without integration SSSC.

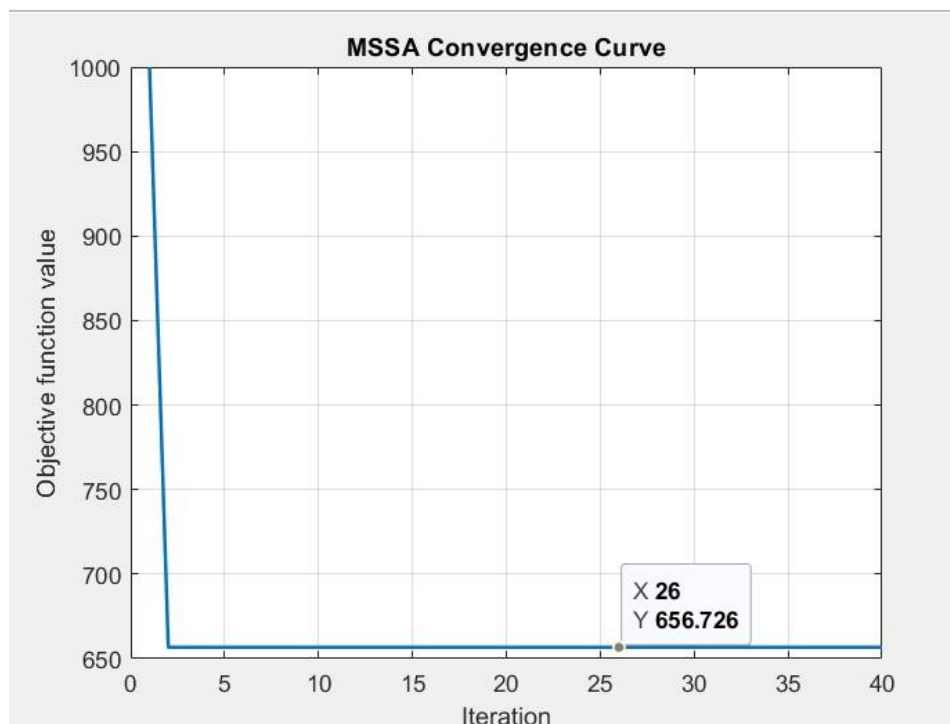

Figure 4.1: Optimizing MSSA Converging Performance to Reduce Power Losses on INPS without including the SSSC

Here, figure 4.1 explains to the performance of the MSSA in minimizing power losses within the INPS, specifically without consideration of SSSC.

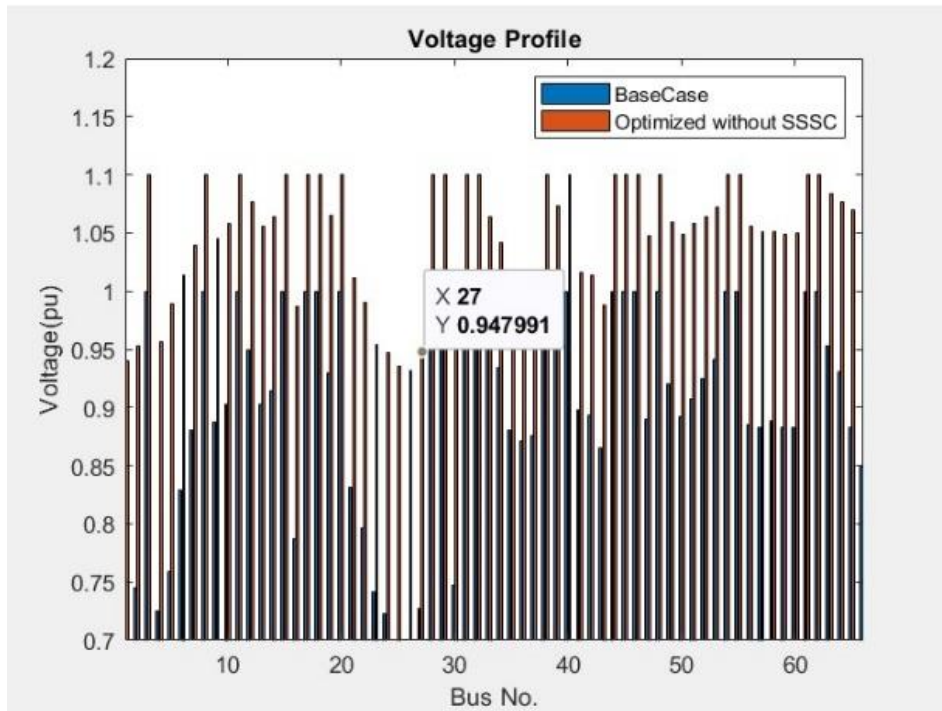

Figure 4.2: Voltage Profile without Inclusion the SSSC on INPS

Here, figure 4.2 explains the improvement of voltage profile in optimized case then the base case after performing load flow analysis without considering the inclusion of SSSC on INPS.

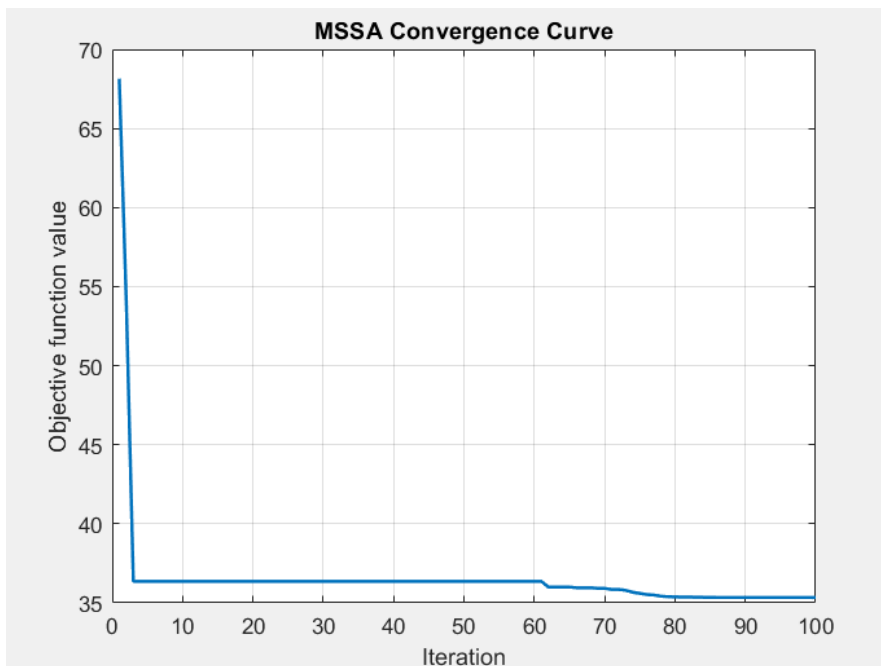

Figure 4.3: Optimizing MSSA Converging Performance to Reduce Power Losses on INPS with including the SSSC

Here, figure 4.3 explains to the performance of the MSSA in minimizing power losses within the INPS, specifically with consideration of SSSC.

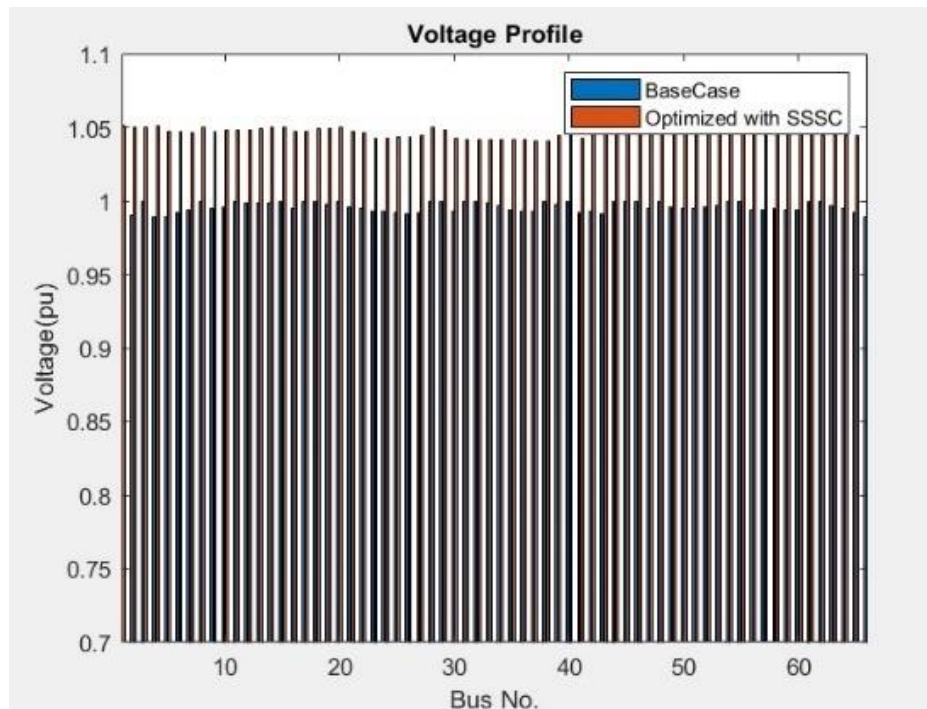

Figure 4.4: Voltage Profile with Inclusion the SSSC on INPS

Here, figure 4.4 explains the improvement of voltage profile in optimized case then the base case after performing load flow analysis on INPS with considering the inclusion of SSSC. After comparing the figure 4.4 with figure 4.2, we see that voltage profile has been improved much after inclusion of SSSC in the system then the system without SSSC. Hence, line losses have been decreased.

Since for the actual scenario of Nepal, there are most P_{RoR}, or peaking run of river, and R_{oR}, or run of river and plant and the data has been taken for the wet condition. So, we cannot optimize the power and cannot fix its value in such as we cannot stop the power plant to decrease the losses, the supply cannot be stopped and power should be exported. Power plant must run in full condition. For that case the value of voltage was not above 0.95 p.u. after optimization and there was no feasible solution within those constraints. Therefore, constraints were relaxed and taken to 0.9 p.u. and was able to get the solution.

Also, the result was compared with and without SSSC in IEEE 30-Bus system and found that there was decrease in the line losses which was 2.743 p.u. with SSSC and

2.984 p.u. without SSSC. After optimization we get the optimum placement of SSSC in the Line 18 which is the branch 12-15 with the optimal size of SSSC as 72.39 MVA. Now the converging performance of MSSA minimization of power losses without and with including SSSC and its voltage profile can be shown and compared as follows:

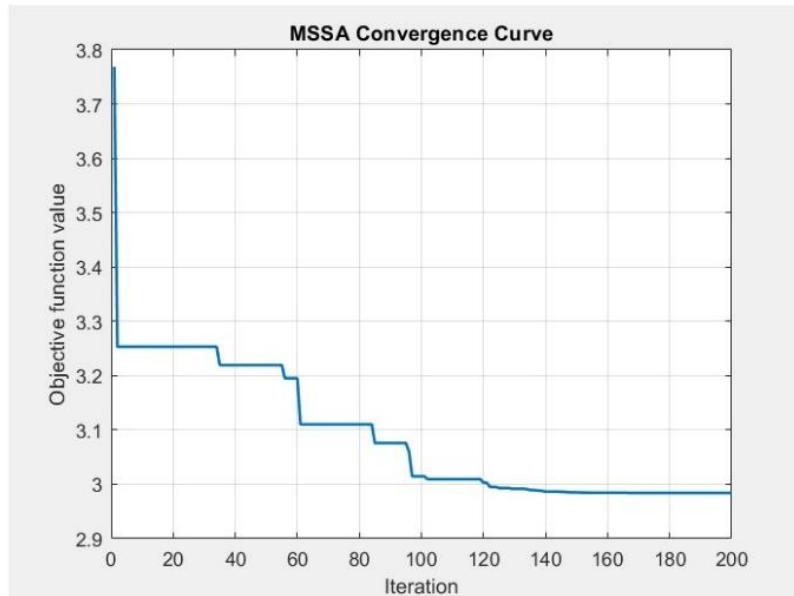

Figure 4.5: Optimizing MSSA Converging Performance to Reduce Power Losses on IEEE 30-Bus System without including the SSSC

Here, figure 4.5 explains to the performance of the MSSA in minimizing power losses within the IEEE 30-Bus system, specifically without considering the inclusion of SSSC.

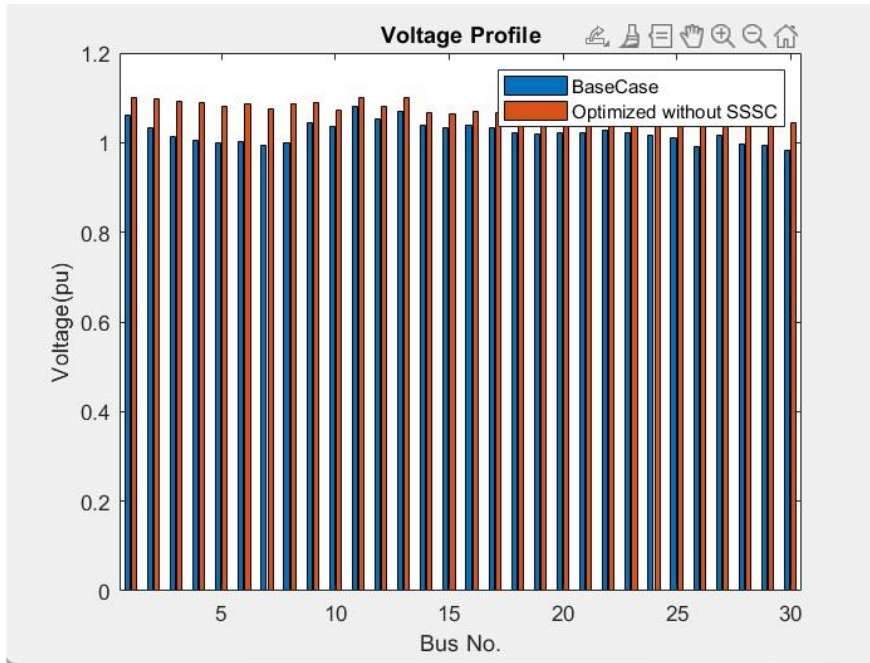

Figure 4.6: Voltage Profile on IEEE 30-Bus System without including SSSC

Here, figure 4.6 explains the improvement of voltage profile in optimized case then the base case after performing load flow analysis without considering the inclusion of SSSC on IEEE 30-Bus system.

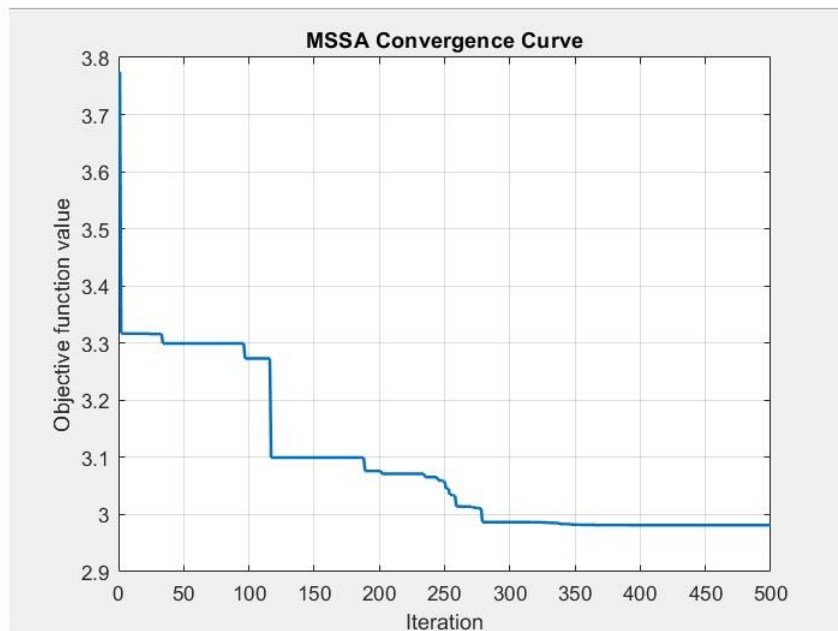

Figure 4.7: Optimizing MSSA Converging Performance to Reduce Power Losses on IEEE 30-Bus System with including the SSSC

Here, figure 4.7 explains to the performance of the MSSA in minimizing power losses within the IEEE 30-Bus system, specifically with consideration of SSSC.

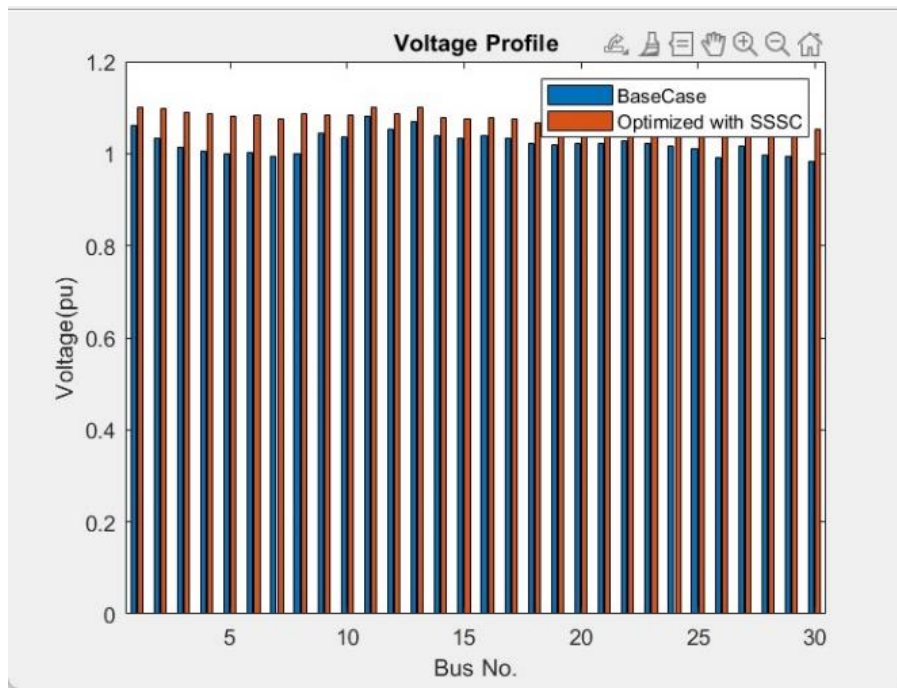

Figure 4.8: Voltage Profile on IEEE 30-Bus System with including SSSC

Here, figure 4.8 explains the improvement of voltage profile in optimized case then the base case after performing load flow analysis on IEEE 30-Bus system with consideration of SSSC. After comparing the figure 4.8 with figure 4.6, we see that voltage profile has been improved much after inclusion of SSSC in the system then the system without SSSC. Hence, we became able to verify the result of INPS with the test result of IEEE 30-Bus system.

CHAPTER 5. CONCLUSION

Hence, we can conclude that this thesis has demonstrated the significant impact of incorporating Static Synchronous Series Compensator (SSSC) devices in optimizing power system operations, specifically through the viewpoint of the Optimal Reactive Power Dispatch i.e. ORPD issue. By applying the Modified Salp Swarm Algorithm i.e. MSSA, the research successfully addressed the complex, non-linear, and non-convex nature of the ORPD problem, particularly with the added dynamics of SSSC control.

The study, conducted on the Integrated Nepal Power System i.e. INPS and benchmarked against the IEEE 30-bus system, revealed substantial improvements in power system performance. The inclusion of the SSSC device led to a notable reduction in line losses from 119.108 MW (5.8% of the total load) to 35.336 MW (1.72% of the total load). This reduction was achieved by optimally sizing the SSSC to 58.307 MVA and placing it on the transmission line between Lahan and Kusaha.

The findings indicate that the SSSC, when combined with an advanced optimization algorithm like the MSSA, can effectively enhance voltage stability, decrease losses of power and increase overall voltage profiles in networks of power transmission. These findings demonstrate the possibility for FACTS devices, particularly the SSSC, to significantly boost the efficiency and reliability of modern power systems. The successful application of the MSSA also underscores its viability as an effective method for resolving challenging optimization issues in electrical engineering. This research lays a strong foundation for future exploration and implementation of FACTS devices in electrical systems to fulfill growing energy demands with enhanced operational efficiency.

ANNEXURE

Annex 1: Load Flow Analysis and Optimization without Inclusion of SSSC in INPS

MATLAB Command Window

Page 98

Runing time: 90.9193

ans =

Columns 1 through 11

1.0279	1.0233	1.0174	1.0057	0.9772	0.9713	0.9842	0.9504	↙
0.9787	0.9781	1.0160						

Columns 12 through 22

1.0180	1.0159	0.9641	0.9725	0.9761	0.9731	1.0089	1.0463	↙
0.9949	1.0021	0.9836						

ans =

Columns 1 through 11

11.8379	10.9994	7.3771	1.1970	0.8459	1.1873	7.3288	14.6029	↙
6.6855	11.2546	14.0133						

Columns 12 through 22

24.2643	0.8615	2.3120	35.5943	27.0817	6.3112	3.0243	45.3062	↙
2.0120	3.4580	26.8359						

Columns 23 through 33

2.4416	20.4327	2.1385	58.2818	41.0179	15.5834	44.0457	18.6759	↙
7.3617	38.1229	9.1837						

Columns 34 through 39

5.0381	7.1376	58.1355	0.9563	8.2393	80.8613			
--------	--------	---------	--------	--------	---------	--	--	--

fobjval =

1000

MATPOWER Version 8.0b1, 22-Dec-2022
Power Flow -- AC-polar-power formulation

Newton's method converged in 4 iterations.
PF successful

Converged in 0.04 seconds

```
=====
|      System Summary      |
=====
```

How many?		How much?	P (MW)	Q (MVar)
Buses	66	Total Gen Capacity	3226.6	-2344.1 to 2344.1
Generators	22	On-line Capacity	3226.6	-2344.1 to 2344.1
Committed Gens	22	Generation (actual)	2129.1	1188.4
Loads	46	Load	2010.0	781.6
Fixed	46	Fixed	2010.0	781.6
Dispatchable	0	Dispatchable	-0.0 of -0.0	-0.0
Shunts	0	Shunt (inj)	-0.0	0.0
Branches	94	Losses (I ² * Z)	119.11	406.82
Transformers	0	Branch Charging (inj)	-	0.0
Inter-ties	0	Total Inter-tie Flow	0.0	0.0
Areas	1			

	Minimum	Maximum
Voltage Magnitude	0.989 p.u. @ bus 4	1.000 p.u. @ bus 3
Voltage Angle	0.00 deg @ bus 38	23.56 deg @ bus 3
P Losses (I ² *R)	-	19.97 MW @ line 22-33
Q Losses (I ² *X)	-	60.79 MVar @ line 22-33

```
=====
|      Bus Data      |
=====
```

Bus #	Voltage		Generation		Load	
	Mag (pu)	Ang (deg)	P (MW)	Q (MVar)	P (MW)	Q (MVar)
1	0.990	21.469	-	-	17.49	6.30
2	0.991	21.547	-	-	15.75	5.66
3	1.000	23.562	120.00	3.28	3.00	1.62
4	0.989	20.704	-	-	10.50	3.78
5	0.989	19.881	-	-	43.68	15.72
6	0.992	19.628	-	-	15.00	5.40
7	0.994	19.583	-	-	18.18	6.54
8	1.000	19.777	48.00	33.70	7.35	3.96
9	0.995	19.447	-	-	10.50	3.78
10	0.996	19.323	-	-	141.27	50.84
11	1.000	20.659	576.00	-49.30	-	-
12	0.999	20.011	-	-	12.24	4.40
13	0.998	19.143	-	-	18.00	6.48
14	0.998	19.204	-	-	47.22	17.00
15	1.000	19.693	99.20	-6.90	-	-
16	0.995	17.336	-	-	31.11	11.20
17	1.000	16.535	276.00	80.96	-	-
18	1.000	18.101	280.00	-72.35	-	-

19	0.998	18.620	-	-	7.47	2.68
20	1.000	18.706	60.00	44.30	-	-
21	0.996	17.257	-	-	22.26	8.00
22	0.995	15.908	-	-	85.05	30.60
23	0.993	12.405	-	-	-	-
24	0.993	12.556	-	-	-	-
25	0.992	13.103	-	-	-	-
26	0.991	13.650	-	-	55.95	20.14
27	0.992	15.003	-	-	10.50	3.78
28	1.000	19.144	180.00	-79.22	-	-
29	1.000	16.403	240.00	13.40	-	-
30	0.993	12.343	-	-	30.00	10.80
31	1.000	10.045	56.00	231.45	-	-
32	1.000	10.261	128.00	51.24	-	-
33	0.998	9.832	-	-	51.00	18.36
34	0.997	9.229	-	-	7.50	2.70
35	0.994	7.055	-	-	7.50	2.70
36	0.993	7.002	-	-	51.81	18.64
37	0.993	4.756	-	-	58.44	21.02
38	1.000	0.000*	-1097.52	534.16	79.26	42.78
39	0.997	1.096	-	-	51.81	18.64
40	1.000	2.224	500.00	33.73	-	-
41	0.992	1.465	0.00	0.00	206.07	111.21
42	0.993	1.572	-	-	7.50	2.70
43	0.991	1.417	-	-	86.64	31.18
44	1.000	2.201	112.80	39.94	7.50	4.05
45	1.000	11.489	88.00	-37.34	-	-
46	1.000	10.927	96.00	-12.53	-	-
47	0.995	10.540	-	-	62.97	22.66
48	1.000	10.827	56.40	137.98	10.50	5.67
49	0.996	10.581	-	-	83.94	30.20
50	0.995	10.534	-	-	76.95	27.68
51	0.995	10.527	-	-	-	-
52	0.996	10.574	-	-	22.74	8.18
53	0.996	10.630	-	-	10.50	3.78
54	1.000	11.439	40.20	-12.72	-	-
55	1.000	10.682	30.00	39.20	-	-
56	0.994	10.430	-	-	90.99	32.74
57	0.994	10.452	-	-	63.09	22.70
58	0.994	10.482	-	-	59.46	21.40
59	0.994	10.452	-	-	48.27	17.36
60	0.994	10.446	-	-	89.19	32.10
61	1.000	10.439	240.00	67.11	10.50	5.67
62	1.000	10.190	0.00	148.30	-	-
63	0.997	9.998	-	-	3.54	1.28
64	0.995	9.903	-	-	40.11	14.44
65	0.992	9.704	-	-	-	-
66	0.990	9.562	-	-	119.67	43.06

Total: 2129.08 1188.40 2009.97 781.58

```

=====
|      Branch Data      |
=====

```

Brnch #	From Bus	To Bus	From Bus Injection		To Bus Injection		Loss (I ² * Z)	
			P (MW)	Q (MVar)	P (MW)	Q (MVar)	P (MW)	Q (MVar)
1	1	2	-17.49	-6.30	17.50	6.33	0.008	0.03
2	2	3	-115.88	2.43	117.00	1.66	1.119	4.09
3	2	4	82.63	-14.42	-82.31	15.61	0.326	1.19
4	4	5	71.81	-19.39	-71.52	20.42	0.282	1.03
5	5	6	16.41	-17.16	-16.38	17.28	0.032	0.12
6	6	7	1.38	-22.68	-1.36	22.73	0.015	0.05
7	5	7	11.43	-18.98	-11.39	19.13	0.042	0.15
8	7	8	-40.52	-29.43	40.65	29.74	0.132	0.31
9	7	9	17.55	-9.49	-17.53	9.54	0.013	0.05
10	7	9	17.55	-9.49	-17.53	9.54	0.013	0.05
11	9	10	12.28	-11.43	-12.27	11.47	0.011	0.04
12	9	10	12.28	-11.43	-12.27	11.47	0.011	0.04
13	10	11	-169.37	11.97	170.29	-8.05	0.918	3.92
14	10	11	-169.37	11.97	170.29	-8.05	0.918	3.92
15	11	12	235.42	-33.19	-234.81	35.82	0.616	2.63
16	12	13	222.57	-40.22	-221.78	43.56	0.784	3.34
17	13	14	-51.73	24.79	51.75	-24.74	0.024	0.06
18	14	15	-98.97	7.74	99.20	-6.90	0.228	0.83
19	13	16	255.51	-74.83	-252.18	82.58	3.328	7.74
20	16	22	221.07	-93.78	-218.71	99.28	2.365	5.50
21	17	18	-277.92	79.98	280.00	-72.35	2.082	7.63
22	10	19	111.01	-48.86	-110.61	50.31	0.397	1.45
23	10	19	111.01	-48.86	-110.61	50.31	0.397	1.45
24	19	20	-59.94	-44.12	60.00	44.30	0.061	0.18
25	19	21	273.69	-59.19	-271.60	65.53	2.087	6.35
26	21	22	249.34	-73.53	-247.44	79.35	1.909	5.81
27	17	22	196.11	37.15	-195.57	-34.84	0.542	2.31
28	17	23	357.81	-36.17	-351.88	61.43	5.924	25.26
29	23	24	-201.31	113.55	201.48	-112.95	0.168	0.61
30	23	58	132.25	-7.63	-132.07	12.07	0.178	4.45
31	24	25	-339.99	123.75	340.91	-120.41	0.917	3.33
32	24	47	138.51	-10.80	-138.32	15.70	0.196	4.90
33	25	26	-340.91	120.41	341.83	-117.08	0.917	3.33
34	26	27	-198.89	48.47	200.16	-43.80	1.275	4.67
35	26	27	-198.89	48.47	200.16	-43.80	1.275	4.67
36	27	28	-172.45	91.29	180.00	-79.22	7.549	12.07
37	27	29	-238.38	-7.47	240.00	13.40	1.624	5.93
38	23	30	210.47	-83.68	-210.41	83.92	0.062	0.24
39	23	30	210.47	-83.68	-210.41	83.92	0.062	0.24
40	30	32	390.82	-178.63	-386.63	193.99	4.191	15.36
41	32	31	514.63	-142.75	-514.09	144.69	0.542	1.94

42	31	33	570.09	86.76	-569.46	-84.50	0.632	2.26
43	22	33	576.66	-174.39	-556.69	235.18	19.971	60.79
44	33	34	553.38	-80.77	-551.82	86.48	1.569	5.71
45	33	62	-25.18	-5.57	25.18	5.74	0.007	0.17
46	34	35	544.32	-89.18	-538.78	109.41	5.539	20.23
47	33	35	546.94	-82.70	-539.85	108.61	7.092	25.91
48	35	36	25.91	9.35	-25.91	-9.32	0.008	0.03
49	35	36	25.91	9.35	-25.91	-9.32	0.008	0.03
50	35	37	509.65	-119.71	-504.13	139.97	5.522	20.26
51	35	37	509.65	-119.71	-504.13	139.97	5.522	20.26
52	37	38	474.91	-150.48	-463.94	190.63	10.969	40.15
53	37	38	474.91	-150.48	-463.94	190.63	10.969	40.15
54	38	39	-124.45	55.06	125.15	-52.53	0.693	2.53
55	38	39	-124.45	55.06	125.15	-52.53	0.693	2.53
56	39	41	-34.81	48.75	34.94	-48.27	0.131	0.48
57	39	40	-267.29	37.67	268.70	-32.49	1.414	5.18
58	40	41	231.30	66.22	-230.33	-62.66	0.972	3.57
59	41	42	-10.69	-0.28	10.69	0.30	0.006	0.02
60	42	43	86.72	31.48	-86.64	-31.18	0.081	0.30
61	42	44	-104.91	-34.48	105.30	35.89	0.386	1.41
62	45	46	88.00	-37.34	-87.63	38.20	0.371	0.86
63	46	47	24.96	3.13	-24.84	-2.95	0.116	0.18
64	46	47	24.96	3.13	-24.84	-2.95	0.116	0.18
65	46	48	133.72	-57.00	-133.62	57.23	0.099	0.23
66	48	49	179.52	75.09	-179.04	-73.99	0.473	1.10
67	49	50	57.52	31.63	-57.48	-31.55	0.035	0.08
68	47	50	19.47	-3.87	-19.47	3.87	0.001	0.00
69	49	51	37.59	12.15	-37.57	-12.11	0.020	0.05
70	51	52	-36.51	-13.71	36.53	13.75	0.018	0.04
71	52	53	-59.27	-21.93	59.30	22.01	0.033	0.08
72	53	54	-39.88	13.24	40.20	-12.72	0.325	0.52
73	53	55	-29.93	-39.03	30.00	39.20	0.071	0.17
74	51	56	74.08	25.82	-74.04	-25.67	0.043	0.16
75	56	57	-16.95	-7.07	16.95	7.08	0.002	0.01
76	57	58	-40.02	-14.89	40.03	14.92	0.013	0.03
77	57	58	-40.02	-14.89	40.03	14.92	0.013	0.03
78	47	58	52.78	-14.29	-52.76	14.35	0.022	0.05
79	47	58	52.78	-14.29	-52.76	14.35	0.022	0.05
80	58	59	64.82	23.58	-64.80	-23.54	0.012	0.04
81	59	60	16.53	6.18	-16.53	-6.18	0.001	0.00
82	58	60	72.67	25.98	-72.66	-25.92	0.016	0.06
83	58	61	-19.71	-70.78	19.88	71.17	0.165	0.38
84	58	61	-19.71	-70.78	19.88	71.17	0.165	0.38
85	61	62	94.87	-40.45	-94.69	40.86	0.177	0.41
86	61	62	94.87	-40.45	-94.69	40.86	0.177	0.41
87	62	63	82.10	30.42	-81.94	-30.05	0.159	0.37
88	62	63	82.10	30.42	-81.94	-30.05	0.159	0.37
89	63	64	80.17	29.41	-80.10	-29.23	0.076	0.18
90	63	64	80.17	29.41	-80.10	-29.23	0.076	0.18

91	64	65	60.04	22.01	-59.92	-21.73	0.120	0.28
92	64	65	60.04	22.01	-59.92	-21.73	0.120	0.28
93	65	66	59.92	21.73	-59.83	-21.53	0.086	0.20
94	65	66	59.92	21.73	-59.83	-21.53	0.086	0.20
							-----	-----
Total:							119.108	406.82

bcTPL =

119.1083

optINPS =

struct with fields:

```

version: '2'
baseMVA: 100
  bus: [66x13 double]
  gen: [22x21 double]
  branch: [94x13 double]
  gencost: [22x7 double]
    
```

MATPOWER Version 8.0b1, 22-Dec-2022
 Power Flow -- AC-polar-power formulation

Newton's method converged in 4 iterations.
 PF successful

Converged in 0.04 seconds

=====
 | System Summary |
 =====

How many?		How much?	P (MW)	Q (MVAr)
Buses	66	Total Gen Capacity	3226.6	-2344.1 to 2344.1
Generators	22	On-line Capacity	3226.6	-2344.1 to 2344.1
Committed Gens	22	Generation (actual)	2258.8	1183.6
Loads	46	Load	2010.0	402.8
Fixed	46	Fixed	2010.0	402.8
Dispatchable	0	Dispatchable	-0.0 of -0.0	-0.0
Shunts	0	Shunt (inj)	-0.0	0.0
Branches	94	Losses (I ² * Z)	248.81	780.79
Transformers	0	Branch Charging (inj)	-	0.0
Inter-ties	0	Total Inter-tie Flow	0.0	0.0
Areas	1			

	Minimum	Maximum
Voltage Magnitude	0.950 p.u. @ bus 28	1.046 p.u. @ bus 54
Voltage Angle	0.00 deg @ bus 38	21.92 deg @ bus 3
P Losses (I ² *R)	-	57.00 MW @ line 32-31
Q Losses (I ² *X)	-	204.02 MVar @ line 32-31

```
=====
|      Bus Data      |
=====
```

Bus #	Voltage		Generation		Load	
	Mag (pu)	Ang (deg)	P (MW)	Q (MVar)	P (MW)	Q (MVar)
1	1.017	19.942	-	-	17.49	-2.39
2	1.017	20.027	-	-	15.75	-2.51
3	1.028	21.917	120.00	7.43	3.00	1.62
4	1.013	19.279	-	-	10.50	-1.71
5	1.008	18.564	-	-	43.68	22.38
6	1.008	18.352	-	-	15.00	7.25
7	1.010	18.321	-	-	18.18	8.62
8	1.023	18.316	48.00	100.18	7.35	3.96
9	1.006	18.263	-	-	10.50	-1.66
10	1.001	18.237	-	-	141.27	61.66
11	1.017	19.352	576.00	232.18	-	-
12	1.012	18.763	-	-	12.24	-0.09
13	1.005	17.974	-	-	18.00	-1.53
14	1.005	18.037	-	-	47.22	11.49
15	1.006	18.539	99.20	-21.18	-	-
16	0.992	16.389	-	-	31.11	-7.46
17	0.977	15.878	276.00	-97.65	-	-
18	0.971	17.623	280.00	-134.87	-	-
19	0.990	17.755	-	-	7.47	3.16
20	0.984	17.988	60.00	-180.16	-	-
21	0.984	16.460	-	-	22.26	9.69
22	0.981	15.173	-	-	85.05	10.31
23	0.991	11.173	-	-	-	-
24	0.990	11.325	-	-	-	-
25	0.986	11.917	-	-	-	-
26	0.982	12.513	-	-	55.95	3.13
27	0.975	14.007	-	-	10.50	-0.64
28	0.950	19.577	180.00	-172.86	-	-
29	0.979	15.529	240.00	-25.23	-	-
30	0.992	11.108	-	-	30.00	13.18
31	0.978	9.385	56.00	-5562.20	-	-
32	1.016	8.965	128.00	5945.62	-	-
33	0.979	9.166	-	-	51.00	-17.77
34	0.980	8.578	-	-	7.50	2.04
35	0.985	6.487	-	-	7.50	0.59
36	0.985	6.428	-	-	51.81	1.12

37	0.993	4.333	-	-	58.44	29.09
38	1.018	0.000*	-967.82	757.31	79.26	42.78
39	1.013	1.084	-	-	51.81	7.53
40	1.016	2.177	500.00	112.60	-	-
41	1.003	1.513	0.00	0.00	206.07	111.21
42	0.983	1.932	-	-	7.50	1.91
43	0.983	1.750	-	-	86.64	-11.51
44	0.973	2.878	112.80	-116.93	7.50	4.05
45	0.976	10.574	88.00	-6.87	-	-
46	0.973	10.056	96.00	-3387.89	-	-
47	0.997	8.991	-	-	62.97	-7.03
48	1.009	9.064	56.40	3560.58	10.50	5.67
49	1.001	8.947	-	-	83.94	29.72
50	0.998	8.968	-	-	76.95	-2.53
51	1.000	8.915	-	-	-	-
52	1.001	8.949	-	-	22.74	-6.41
53	1.002	9.003	-	-	10.50	-1.69
54	1.046	8.297	40.20	134.94	-	-
55	0.995	9.307	30.00	-111.85	-	-
56	0.998	8.843	-	-	90.99	10.99
57	0.997	8.897	-	-	63.09	24.87
58	0.997	8.941	-	-	59.46	27.06
59	0.997	8.909	-	-	48.27	18.90
60	0.997	8.902	-	-	89.19	-9.99
61	1.002	8.959	240.00	996.73	10.50	5.67
62	0.984	9.190	0.00	-846.26	-	-
63	0.982	8.954	-	-	3.54	0.96
64	0.981	8.838	-	-	40.11	13.42
65	0.980	8.582	-	-	-	-
66	0.979	8.399	-	-	119.67	-16.27
Total:			2258.78	1183.64	2009.97	402.85

Branch Data								
Brnch #	From Bus	To Bus	From Bus P (MW)	Injection Q (MVar)	To Bus P (MW)	Injection Q (MVar)	Loss (I ² * Z)	
							P (MW)	Q (MVar)
1	1	2	-17.49	2.39	17.50	-2.36	0.007	0.03
2	2	3	-115.94	-1.93	117.00	5.81	1.061	3.88
3	2	4	82.69	6.80	-82.39	-5.69	0.303	1.11
4	4	5	71.89	7.40	-71.64	-6.47	0.254	0.93
5	5	6	16.47	-6.74	-16.45	6.80	0.017	0.06
6	6	7	1.45	-14.06	-1.45	14.08	0.006	0.02
7	5	7	11.48	-9.17	-11.47	9.24	0.018	0.07
8	7	8	-40.11	-94.96	40.65	96.22	0.542	1.26
9	7	9	17.42	31.51	-17.38	-31.36	0.040	0.15
10	7	9	17.42	31.51	-17.38	-31.36	0.040	0.15

11	9	10	12.13	32.19	-12.09	-32.03	0.044	0.16
12	9	10	12.13	32.19	-12.09	-32.03	0.044	0.16
13	10	11	-166.37	-83.00	167.46	87.66	1.091	4.66
14	10	11	-166.37	-83.00	167.46	87.66	1.091	4.66
15	11	12	241.07	56.86	-240.42	-54.10	0.646	2.76
16	12	13	228.18	54.19	-227.36	-50.69	0.821	3.49
17	13	14	-51.72	33.59	51.74	-33.52	0.027	0.06
18	14	15	-98.96	22.04	99.20	-21.18	0.235	0.86
19	13	16	261.08	18.64	-257.91	-11.26	3.172	7.38
20	16	22	226.80	18.72	-224.66	-13.75	2.138	4.97
21	17	18	-277.45	144.20	280.00	-134.87	2.549	9.34
22	10	19	107.83	84.20	-107.32	-82.37	0.501	1.83
23	10	19	107.83	84.20	-107.32	-82.37	0.501	1.83
24	19	20	-59.59	181.39	60.00	-180.16	0.406	1.24
25	19	21	266.77	-19.81	-264.84	25.70	1.936	5.89
26	21	22	242.58	-35.39	-240.84	40.68	1.737	5.29
27	17	22	179.75	-99.94	-179.14	102.52	0.602	2.57
28	17	23	373.70	-141.91	-366.04	174.59	7.663	32.68
29	23	24	-173.05	216.59	173.29	-215.72	0.242	0.88
30	23	58	152.95	-26.65	-152.70	32.78	0.245	6.13
31	24	25	-332.70	249.07	333.92	-244.64	1.217	4.43
32	24	47	159.42	-33.35	-159.15	40.12	0.271	6.77
33	25	26	-333.92	244.64	335.14	-240.21	1.217	4.43
34	26	27	-195.54	118.54	197.17	-112.60	1.622	5.94
35	26	27	-195.54	118.54	197.17	-112.60	1.622	5.94
36	27	28	-166.54	194.38	180.00	-172.86	13.459	21.52
37	27	29	-238.29	31.46	240.00	-25.23	1.708	6.24
38	23	30	193.07	-182.27	-192.98	182.60	0.086	0.33
39	23	30	193.07	-182.27	-192.98	182.60	0.086	0.33
40	30	32	355.97	-378.37	-349.82	400.89	6.143	22.51
41	32	31	477.82	5544.74	-420.82	-5340.72	57.005	204.02
42	31	33	476.82	-221.48	-476.27	223.44	0.549	1.96
43	22	33	559.60	-139.75	-540.75	197.13	18.849	57.38
44	33	34	487.37	-191.12	-485.94	196.33	1.431	5.21
45	33	62	-2.39	-19.26	2.40	19.36	0.004	0.10
46	34	35	478.44	-198.37	-473.38	216.84	5.058	18.47
47	33	35	481.04	-192.42	-474.57	216.07	6.474	23.65
48	35	36	25.91	0.59	-25.91	-0.56	0.007	0.03
49	35	36	25.91	0.59	-25.91	-0.56	0.007	0.03
50	35	37	444.31	-217.34	-439.29	235.75	5.018	18.41
51	35	37	444.31	-217.34	-439.29	235.75	5.018	18.41
52	37	38	410.07	-250.29	-399.86	287.66	10.209	37.37
53	37	38	410.07	-250.29	-399.86	287.66	10.209	37.37
54	38	39	-123.68	69.61	124.40	-66.95	0.727	2.66
55	38	39	-123.68	69.61	124.40	-66.95	0.727	2.66
56	39	41	-33.69	87.10	33.99	-85.98	0.307	1.12
57	39	40	-266.93	39.26	268.30	-34.25	1.368	5.01
58	40	41	231.70	146.86	-230.48	-142.36	1.225	4.49
59	41	42	-9.59	117.13	10.24	-114.75	0.651	2.38

60	42	43	86.71	-11.24	-86.64	11.51	0.074	0.27
61	42	44	-104.45	124.08	105.30	-120.98	0.849	3.10
62	45	46	88.00	-6.87	-87.67	7.64	0.332	0.77
63	46	47	8.59	-84.96	-7.19	87.20	1.407	2.25
64	46	47	8.59	-84.96	-7.19	87.20	1.407	2.25
65	46	48	166.48	-3225.62	-114.71	3346.80	51.778	121.18
66	48	49	160.61	208.11	-159.76	-206.14	0.849	1.97
67	49	50	44.58	149.17	-44.39	-148.72	0.194	0.45
68	47	50	32.60	-151.13	-32.56	151.24	0.038	0.11
69	49	51	31.24	27.26	-31.22	-27.21	0.021	0.05
70	51	52	-33.21	-24.87	33.23	24.91	0.020	0.05
71	52	53	-55.97	-18.51	56.00	18.57	0.029	0.07
72	53	54	-36.89	-129.65	40.20	134.94	3.309	5.29
73	53	55	-29.61	112.77	30.00	-111.85	0.394	0.92
74	51	56	64.43	52.08	-64.38	-51.91	0.047	0.17
75	56	57	-26.61	40.92	26.63	-40.86	0.017	0.06
76	57	58	-44.86	8.00	44.87	-7.96	0.014	0.03
77	57	58	-44.86	8.00	44.87	-7.96	0.014	0.03
78	47	58	38.97	-28.19	-38.95	28.23	0.017	0.04
79	47	58	38.97	-28.19	-38.95	28.23	0.017	0.04
80	58	59	64.89	8.53	-64.88	-8.49	0.010	0.04
81	59	60	16.61	-10.41	-16.61	10.42	0.001	0.00
82	58	60	72.59	0.48	-72.58	-0.43	0.014	0.05
83	58	61	-28.04	-54.68	28.15	54.95	0.115	0.27
84	58	61	-28.04	-54.68	28.15	54.95	0.115	0.27
85	61	62	86.60	440.58	-83.26	-432.81	3.333	7.77
86	61	62	86.60	440.58	-83.26	-432.81	3.333	7.77
87	62	63	82.06	-0.00	-81.92	0.34	0.145	0.34
88	62	63	82.06	-0.00	-81.92	0.34	0.145	0.34
89	63	64	80.15	-0.82	-80.08	0.98	0.069	0.16
90	63	64	80.15	-0.82	-80.08	0.98	0.069	0.16
91	64	65	60.02	-7.69	-59.91	7.95	0.111	0.26
92	64	65	60.02	-7.69	-59.91	7.95	0.111	0.26
93	65	66	59.91	-7.95	-59.84	8.14	0.079	0.18
94	65	66	59.91	-7.95	-59.84	8.14	0.079	0.18
							-----	-----
Total:							248.809	780.79

VDIb =

0.2662

VDIopt =

0.9117

>>

Annex 2: Load Flow Analysis and Optimization with Inclusion of SSSC in INPS

MATLAB Command Window

Page 93

Runing time: 185.6938

ans =

Columns 1 through 11

1.0496	1.0500	1.0479	1.0500	1.0477	1.0492	1.0498	1.0500	↵
1.0479	1.0416	1.0417						

Columns 12 through 22

1.0404	1.0494	1.0470	1.0500	1.0482	1.0475	1.0472	1.0471	↵
1.0473	1.0458	1.0448						

ans =

38.6143	288.0000	99.1083	196.8224	279.5713	59.9819	178.9047	120.1497	↵
43.2494	64.1418	0						

ans =

498.8835	0	112.6558	44.0683	95.9956	56.2432	20.1362	15.0116	↵
239.4757	0							

ans =

Columns 1 through 11

0.0158	0.0142	0.0095	0.0393	0.0135	0.0163	0.0095	0.1271	↵
0.0110	0.0162	0.0425						

Columns 12 through 22

0.0280	0.0067	0.0200	0.0765	0.0503	0.0095	0.0270	0.0459	↵
0.0067	0.0067	0.0466						

Columns 23 through 33

0.0525	0.0466	0.0067	0.0780	0.0566	0.0755	0.0692	0.0204	↵
0.0095	0.0819	0.0568						

Columns 34 through 39

0.0535	0.0434	0.0803	0.0032	0.0361	0.1077			
--------	--------	--------	--------	--------	--------	--	--	--

ans =

4

ans =

0.2000

ans =

3.1378

fobjval =

35.3347

MATPOWER Version 8.0b1, 22-Dec-2022
 Power Flow -- AC-polar-power formulation

Newton's method converged in 4 iterations.
 PF successful

Converged in 0.03 seconds

=====
 | System Summary |
 =====

How many?		How much?	P (MW)	Q (MVar)
Buses	66	Total Gen Capacity	3226.6	-2344.1 to 2344.1
Generators	22	On-line Capacity	3226.6	-2344.1 to 2344.1
Committed Gens	22	Generation (actual)	2129.1	1188.4
Loads	46	Load	2010.0	781.6
Fixed	46	Fixed	2010.0	781.6
Dispatchable	0	Dispatchable	-0.0 of -0.0	-0.0
Shunts	0	Shunt (inj)	-0.0	0.0
Branches	94	Losses (I ² * Z)	119.11	406.82
Transformers	0	Branch Charging (inj)	-	0.0
Inter-ties	0	Total Inter-tie Flow	0.0	0.0
Areas	1			

	Minimum	Maximum
Voltage Magnitude	0.989 p.u. @ bus 4	1.000 p.u. @ bus 3
Voltage Angle	0.00 deg @ bus 38	23.56 deg @ bus 3

P Losses (I^2*R) - 19.97 MW @ line 22-33
 Q Losses (I^2*X) - 60.79 MVar @ line 22-33

```
=====
|      Bus Data      |
=====
```

Bus #	Voltage		Generation		Load	
	Mag (pu)	Ang (deg)	P (MW)	Q (MVar)	P (MW)	Q (MVar)
1	0.990	21.469	-	-	17.49	6.30
2	0.991	21.547	-	-	15.75	5.66
3	1.000	23.562	120.00	3.28	3.00	1.62
4	0.989	20.704	-	-	10.50	3.78
5	0.989	19.881	-	-	43.68	15.72
6	0.992	19.628	-	-	15.00	5.40
7	0.994	19.583	-	-	18.18	6.54
8	1.000	19.777	48.00	33.70	7.35	3.96
9	0.995	19.447	-	-	10.50	3.78
10	0.996	19.323	-	-	141.27	50.84
11	1.000	20.659	576.00	-49.30	-	-
12	0.999	20.011	-	-	12.24	4.40
13	0.998	19.143	-	-	18.00	6.48
14	0.998	19.204	-	-	47.22	17.00
15	1.000	19.693	99.20	-6.90	-	-
16	0.995	17.336	-	-	31.11	11.20
17	1.000	16.535	276.00	80.96	-	-
18	1.000	18.101	280.00	-72.35	-	-
19	0.998	18.620	-	-	7.47	2.68
20	1.000	18.706	60.00	44.30	-	-
21	0.996	17.257	-	-	22.26	8.00
22	0.995	15.908	-	-	85.05	30.60
23	0.993	12.405	-	-	-	-
24	0.993	12.556	-	-	-	-
25	0.992	13.103	-	-	-	-
26	0.991	13.650	-	-	55.95	20.14
27	0.992	15.003	-	-	10.50	3.78
28	1.000	19.144	180.00	-79.22	-	-
29	1.000	16.403	240.00	13.40	-	-
30	0.993	12.343	-	-	30.00	10.80
31	1.000	10.045	56.00	231.45	-	-
32	1.000	10.261	128.00	51.24	-	-
33	0.998	9.832	-	-	51.00	18.36
34	0.997	9.229	-	-	7.50	2.70
35	0.994	7.055	-	-	7.50	2.70
36	0.993	7.002	-	-	51.81	18.64
37	0.993	4.756	-	-	58.44	21.02
38	1.000	0.000*	-1097.52	534.16	79.26	42.78
39	0.997	1.096	-	-	51.81	18.64
40	1.000	2.224	500.00	33.73	-	-

41	0.992	1.465	0.00	0.00	206.07	111.21
42	0.993	1.572	-	-	7.50	2.70
43	0.991	1.417	-	-	86.64	31.18
44	1.000	2.201	112.80	39.94	7.50	4.05
45	1.000	11.489	88.00	-37.34	-	-
46	1.000	10.927	96.00	-12.53	-	-
47	0.995	10.540	-	-	62.97	22.66
48	1.000	10.827	56.40	137.98	10.50	5.67
49	0.996	10.581	-	-	83.94	30.20
50	0.995	10.534	-	-	76.95	27.68
51	0.995	10.527	-	-	-	-
52	0.996	10.574	-	-	22.74	8.18
53	0.996	10.630	-	-	10.50	3.78
54	1.000	11.439	40.20	-12.72	-	-
55	1.000	10.682	30.00	39.20	-	-
56	0.994	10.430	-	-	90.99	32.74
57	0.994	10.452	-	-	63.09	22.70
58	0.994	10.482	-	-	59.46	21.40
59	0.994	10.452	-	-	48.27	17.36
60	0.994	10.446	-	-	89.19	32.10
61	1.000	10.439	240.00	67.11	10.50	5.67
62	1.000	10.190	0.00	148.30	-	-
63	0.997	9.998	-	-	3.54	1.28
64	0.995	9.903	-	-	40.11	14.44
65	0.992	9.704	-	-	-	-
66	0.990	9.562	-	-	119.67	43.06
Total:			2129.08	1188.40	2009.97	781.58

```

=====
|      Branch Data      |
=====

```

Brnch #	From Bus	To Bus	From Bus Injection		To Bus Injection		Loss (I ² * Z)	
			P (MW)	Q (MVar)	P (MW)	Q (MVar)	P (MW)	Q (MVar)
1	1	2	-17.49	-6.30	17.50	6.33	0.008	0.03
2	2	3	-115.88	2.43	117.00	1.66	1.119	4.09
3	2	4	82.63	-14.42	-82.31	15.61	0.326	1.19
4	4	5	71.81	-19.39	-71.52	20.42	0.282	1.03
5	5	6	16.41	-17.16	-16.38	17.28	0.032	0.12
6	6	7	1.38	-22.68	-1.36	22.73	0.015	0.05
7	5	7	11.43	-18.98	-11.39	19.13	0.042	0.15
8	7	8	-40.52	-29.43	40.65	29.74	0.132	0.31
9	7	9	17.55	-9.49	-17.53	9.54	0.013	0.05
10	7	9	17.55	-9.49	-17.53	9.54	0.013	0.05
11	9	10	12.28	-11.43	-12.27	11.47	0.011	0.04
12	9	10	12.28	-11.43	-12.27	11.47	0.011	0.04
13	10	11	-169.37	11.97	170.29	-8.05	0.918	3.92
14	10	11	-169.37	11.97	170.29	-8.05	0.918	3.92

15	11	12	235.42	-33.19	-234.81	35.82	0.616	2.63
16	12	13	222.57	-40.22	-221.78	43.56	0.784	3.34
17	13	14	-51.73	24.79	51.75	-24.74	0.024	0.06
18	14	15	-98.97	7.74	99.20	-6.90	0.228	0.83
19	13	16	255.51	-74.83	-252.18	82.58	3.328	7.74
20	16	22	221.07	-93.78	-218.71	99.28	2.365	5.50
21	17	18	-277.92	79.98	280.00	-72.35	2.082	7.63
22	10	19	111.01	-48.86	-110.61	50.31	0.397	1.45
23	10	19	111.01	-48.86	-110.61	50.31	0.397	1.45
24	19	20	-59.94	-44.12	60.00	44.30	0.061	0.18
25	19	21	273.69	-59.19	-271.60	65.53	2.087	6.35
26	21	22	249.34	-73.53	-247.44	79.35	1.909	5.81
27	17	22	196.11	37.15	-195.57	-34.84	0.542	2.31
28	17	23	357.81	-36.17	-351.88	61.43	5.924	25.26
29	23	24	-201.31	113.55	201.48	-112.95	0.168	0.61
30	23	58	132.25	-7.63	-132.07	12.07	0.178	4.45
31	24	25	-339.99	123.75	340.91	-120.41	0.917	3.33
32	24	47	138.51	-10.80	-138.32	15.70	0.196	4.90
33	25	26	-340.91	120.41	341.83	-117.08	0.917	3.33
34	26	27	-198.89	48.47	200.16	-43.80	1.275	4.67
35	26	27	-198.89	48.47	200.16	-43.80	1.275	4.67
36	27	28	-172.45	91.29	180.00	-79.22	7.549	12.07
37	27	29	-238.38	-7.47	240.00	13.40	1.624	5.93
38	23	30	210.47	-83.68	-210.41	83.92	0.062	0.24
39	23	30	210.47	-83.68	-210.41	83.92	0.062	0.24
40	30	32	390.82	-178.63	-386.63	193.99	4.191	15.36
41	32	31	514.63	-142.75	-514.09	144.69	0.542	1.94
42	31	33	570.09	86.76	-569.46	-84.50	0.632	2.26
43	22	33	576.66	-174.39	-556.69	235.18	19.971	60.79
44	33	34	553.38	-80.77	-551.82	86.48	1.569	5.71
45	33	62	-25.18	-5.57	25.18	5.74	0.007	0.17
46	34	35	544.32	-89.18	-538.78	109.41	5.539	20.23
47	33	35	546.94	-82.70	-539.85	108.61	7.092	25.91
48	35	36	25.91	9.35	-25.91	-9.32	0.008	0.03
49	35	36	25.91	9.35	-25.91	-9.32	0.008	0.03
50	35	37	509.65	-119.71	-504.13	139.97	5.522	20.26
51	35	37	509.65	-119.71	-504.13	139.97	5.522	20.26
52	37	38	474.91	-150.48	-463.94	190.63	10.969	40.15
53	37	38	474.91	-150.48	-463.94	190.63	10.969	40.15
54	38	39	-124.45	55.06	125.15	-52.53	0.693	2.53
55	38	39	-124.45	55.06	125.15	-52.53	0.693	2.53
56	39	41	-34.81	48.75	34.94	-48.27	0.131	0.48
57	39	40	-267.29	37.67	268.70	-32.49	1.414	5.18
58	40	41	231.30	66.22	-230.33	-62.66	0.972	3.57
59	41	42	-10.69	-0.28	10.69	0.30	0.006	0.02
60	42	43	86.72	31.48	-86.64	-31.18	0.081	0.30
61	42	44	-104.91	-34.48	105.30	35.89	0.386	1.41
62	45	46	88.00	-37.34	-87.63	38.20	0.371	0.86
63	46	47	24.96	3.13	-24.84	-2.95	0.116	0.18

64	46	47	24.96	3.13	-24.84	-2.95	0.116	0.18	
65	46	48	133.72	-57.00	-133.62	57.23	0.099	0.23	
66	48	49	179.52	75.09	-179.04	-73.99	0.473	1.10	
67	49	50	57.52	31.63	-57.48	-31.55	0.035	0.08	
68	47	50	19.47	-3.87	-19.47	3.87	0.001	0.00	
69	49	51	37.59	12.15	-37.57	-12.11	0.020	0.05	
70	51	52	-36.51	-13.71	36.53	13.75	0.018	0.04	
71	52	53	-59.27	-21.93	59.30	22.01	0.033	0.08	
72	53	54	-39.88	13.24	40.20	-12.72	0.325	0.52	
73	53	55	-29.93	-39.03	30.00	39.20	0.071	0.17	
74	51	56	74.08	25.82	-74.04	-25.67	0.043	0.16	
75	56	57	-16.95	-7.07	16.95	7.08	0.002	0.01	
76	57	58	-40.02	-14.89	40.03	14.92	0.013	0.03	
77	57	58	-40.02	-14.89	40.03	14.92	0.013	0.03	
78	47	58	52.78	-14.29	-52.76	14.35	0.022	0.05	
79	47	58	52.78	-14.29	-52.76	14.35	0.022	0.05	
80	58	59	64.82	23.58	-64.80	-23.54	0.012	0.04	
81	59	60	16.53	6.18	-16.53	-6.18	0.001	0.00	
82	58	60	72.67	25.98	-72.66	-25.92	0.016	0.06	
83	58	61	-19.71	-70.78	19.88	71.17	0.165	0.38	
84	58	61	-19.71	-70.78	19.88	71.17	0.165	0.38	
85	61	62	94.87	-40.45	-94.69	40.86	0.177	0.41	
86	61	62	94.87	-40.45	-94.69	40.86	0.177	0.41	
87	62	63	82.10	30.42	-81.94	-30.05	0.159	0.37	
88	62	63	82.10	30.42	-81.94	-30.05	0.159	0.37	
89	63	64	80.17	29.41	-80.10	-29.23	0.076	0.18	
90	63	64	80.17	29.41	-80.10	-29.23	0.076	0.18	
91	64	65	60.04	22.01	-59.92	-21.73	0.120	0.28	
92	64	65	60.04	22.01	-59.92	-21.73	0.120	0.28	
93	65	66	59.92	21.73	-59.83	-21.53	0.086	0.20	
94	65	66	59.92	21.73	-59.83	-21.53	0.086	0.20	
							Total:	119.108	406.82

bcTPL =

119.1083

MATPOWER Version 8.0b1, 22-Dec-2022
 Power Flow -- AC-polar-power formulation

Newton's method converged in 4 iterations.
 PF successful

Converged in 0.03 seconds

```
=====
|           System Summary           |
=====
```

22	1.046	5.754	-	-	85.05	-30.60
23	1.043	3.017	-	-	-	-
24	1.043	2.997	-	-	-	-
25	1.043	3.125	-	-	-	-
26	1.044	3.252	-	-	55.95	-20.14
27	1.044	3.706	-	-	10.50	-3.78
28	1.050	6.203	120.15	-52.64	-	-
29	1.048	3.901	43.25	25.01	-	-
30	1.043	3.003	-	-	30.00	-10.80
31	1.042	2.591	64.14	-20.83	-	-
32	1.042	2.623	0.00	-4.86	-	-
33	1.042	2.533	-	-	51.00	-18.36
34	1.041	2.343	-	-	7.50	-2.70
35	1.041	1.678	-	-	7.50	-2.70
36	1.041	1.620	-	-	51.81	-18.64
37	1.041	1.067	-	-	58.44	-21.02
38	1.040	0.000*	-405.74	111.58	79.26	42.78
39	1.044	0.906	-	-	51.81	-18.64
40	1.049	1.890	498.88	66.29	-	-
41	1.042	1.197	0.00	0.00	206.07	111.21
42	1.047	1.224	-	-	7.50	-2.70
43	1.048	1.054	-	-	86.64	-31.18
44	1.050	1.855	112.66	-0.21	7.50	4.05
45	1.048	1.938	44.07	-11.53	-	-
46	1.048	1.697	96.00	-20.31	-	-
47	1.047	1.356	-	-	62.97	-22.66
48	1.047	1.632	56.24	-33.49	10.50	5.67
49	1.047	1.367	-	-	83.94	-30.20
50	1.047	1.341	-	-	76.95	-27.68
51	1.047	1.289	-	-	-	-
52	1.047	1.291	-	-	22.74	-8.18
53	1.047	1.320	-	-	10.50	-3.78
54	1.047	1.740	20.14	-11.85	-	-
55	1.047	1.373	15.01	0.09	-	-
56	1.047	1.222	-	-	90.99	-32.74
57	1.047	1.287	-	-	63.09	-22.70
58	1.047	1.338	-	-	59.46	-21.40
59	1.047	1.305	-	-	48.27	-17.36
60	1.047	1.299	-	-	89.19	-32.10
61	1.046	1.658	239.48	-62.51	10.50	5.67
62	1.045	1.573	0.00	-58.48	-	-
63	1.044	1.334	-	-	3.54	-1.28
64	1.044	1.216	-	-	40.11	-14.44
65	1.044	0.970	-	-	-	-
66	1.044	0.795	-	-	119.67	-43.06
			-----	-----	-----	-----
		Total:	2045.28	-316.67	2009.94	-431.71

=====

Branch Data								
Brnch #	From Bus	To Bus	From Bus Injection		To Bus Injection		Loss ($I^2 * Z$)	
			P (MW)	Q (MVar)	P (MW)	Q (MVar)	P (MW)	Q (MVar)
1	1	2	-17.49	6.30	17.50	-6.27	0.007	0.03
2	2	3	-35.51	12.93	35.61	-12.54	0.106	0.39
3	2	4	2.26	-0.99	-2.26	0.99	0.000	0.00
4	4	5	-7.76	5.81	7.76	-5.75	0.006	0.06
5	5	6	-23.45	8.34	23.48	-8.22	0.032	0.12
6	6	7	-38.48	13.62	38.53	-13.47	0.043	0.16
7	5	7	-28.44	10.16	28.51	-9.91	0.070	0.26
8	7	8	-276.59	94.93	280.65	-85.48	4.060	9.45
9	7	9	95.69	-32.51	-95.39	33.59	0.296	1.08
10	7	9	95.69	-32.51	-95.39	33.59	0.296	1.08
11	9	10	90.14	-31.70	-89.82	32.86	0.316	1.16
12	9	10	90.14	-31.70	-89.82	32.86	0.316	1.16
13	10	11	-15.59	7.72	15.59	-7.69	0.009	0.04
14	10	11	-15.59	7.72	15.59	-7.69	0.009	0.04
15	11	12	67.92	-31.77	-67.86	32.01	0.056	0.24
16	12	13	55.62	-27.61	-55.57	27.84	0.054	0.23
17	13	14	-148.58	37.57	148.74	-37.21	0.156	0.36
18	14	15	-195.96	54.21	196.82	-51.05	0.866	3.17
19	13	16	186.15	-58.93	-184.53	62.70	1.620	3.77
20	16	22	153.42	-51.50	-152.45	53.75	0.969	2.25
21	17	18	-59.90	-1.49	59.98	1.78	0.081	0.30
22	10	19	34.77	-15.16	-34.74	15.29	0.035	0.13
23	10	19	34.77	-15.16	-34.74	15.29	0.035	0.13
24	19	20	-178.58	30.31	178.90	-29.32	0.325	0.99
25	19	21	240.58	-58.22	-239.11	62.70	1.476	4.49
26	21	22	216.85	-54.70	-215.57	58.59	1.276	3.89
27	17	22	62.22	9.29	-62.17	-9.08	0.049	0.21
28	17	23	277.26	-32.55	-274.00	46.42	3.252	13.87
29	23	24	30.93	-9.39	-30.92	9.40	0.003	0.01
30	23	58	127.21	-19.27	-127.06	23.07	0.152	3.80
31	24	25	-93.41	10.39	93.46	-10.19	0.056	0.20
32	24	47	124.33	-19.79	-124.18	23.43	0.146	3.64
33	25	26	-93.46	10.19	93.52	-9.99	0.056	0.20
34	26	27	-74.73	15.06	74.89	-14.48	0.160	0.58
35	26	27	-74.73	15.06	74.89	-14.48	0.160	0.58
36	27	28	-117.10	57.51	120.15	-52.64	3.047	4.87
37	27	29	-43.19	-24.78	43.25	25.01	0.064	0.23
38	23	30	57.93	-8.88	-57.93	8.90	0.004	0.01
39	23	30	57.93	-8.88	-57.93	8.90	0.004	0.01
40	30	32	85.86	-6.99	-85.71	7.55	0.153	0.56
41	32	31	85.71	-12.41	-85.70	12.46	0.013	0.05
42	31	33	149.84	-33.29	-149.80	33.44	0.041	0.15
43	22	33	345.14	-72.67	-338.95	91.52	6.193	18.85
44	33	34	185.76	-46.50	-185.59	47.12	0.169	0.62

45	33	62	72.30	-15.80	-72.25	17.06	0.050	1.26
46	34	35	178.09	-44.42	-177.53	46.47	0.562	2.05
47	33	35	179.68	-44.30	-178.96	46.96	0.729	2.66
48	35	36	25.91	-9.29	-25.90	9.32	0.007	0.03
49	35	36	25.91	-9.29	-25.90	9.32	0.007	0.03
50	35	37	148.58	-36.07	-148.15	37.65	0.429	1.57
51	35	37	148.58	-36.07	-148.15	37.65	0.429	1.57
52	37	38	118.93	-27.14	-118.33	29.33	0.599	2.19
53	37	38	118.93	-27.14	-118.33	29.33	0.599	2.19
54	38	39	-124.17	5.07	124.70	-3.12	0.534	1.95
55	38	39	-124.17	5.07	124.70	-3.12	0.534	1.95
56	39	41	-34.78	25.80	34.84	-25.58	0.062	0.23
57	39	40	-266.44	-0.93	267.69	5.53	1.256	4.60
58	40	41	231.19	60.76	-230.32	-57.57	0.872	3.20
59	41	42	-10.59	-28.06	10.63	28.21	0.039	0.14
60	42	43	86.71	-30.92	-86.64	31.18	0.073	0.26
61	42	44	-104.84	5.41	105.16	-4.26	0.313	1.15
62	45	46	44.07	-11.53	-43.99	11.71	0.077	0.18
63	46	47	17.06	-8.44	-17.00	8.54	0.060	0.10
64	46	47	17.06	-8.44	-17.00	8.54	0.060	0.10
65	46	48	105.88	-15.13	-105.83	15.24	0.049	0.11
66	48	49	151.57	-54.40	-151.27	55.09	0.296	0.69
67	49	50	22.44	-9.74	-22.43	9.76	0.004	0.01
68	47	50	54.52	-17.91	-54.52	17.92	0.005	0.01
69	49	51	44.90	-15.14	-44.87	15.20	0.026	0.06
70	51	52	-1.81	-0.03	1.81	0.03	0.000	0.00
71	52	53	-24.55	8.15	24.55	-8.14	0.005	0.01
72	53	54	-20.05	11.99	20.14	-11.85	0.091	0.15
73	53	55	-15.01	-0.07	15.01	0.09	0.006	0.01
74	51	56	46.68	-15.17	-46.66	15.23	0.015	0.06
75	56	57	-44.33	17.51	44.34	-17.46	0.014	0.05
76	57	58	-53.72	20.08	53.74	-20.03	0.020	0.05
77	57	58	-53.72	20.08	53.74	-20.03	0.020	0.05
78	47	58	20.34	0.03	-20.34	-0.02	0.003	0.01
79	47	58	20.34	0.03	-20.34	-0.02	0.003	0.01
80	58	59	64.95	-23.10	-64.94	23.14	0.010	0.04
81	59	60	16.67	-5.78	-16.67	5.78	0.000	0.00
82	58	60	72.53	-26.27	-72.52	26.32	0.014	0.05
83	58	61	-68.34	43.90	68.52	-43.48	0.182	0.42
84	58	61	-68.34	43.90	68.52	-43.48	0.182	0.42
85	61	62	45.96	9.39	-45.93	-9.31	0.033	0.08
86	61	62	45.96	9.39	-45.93	-9.31	0.033	0.08
87	62	63	82.06	-28.46	-81.91	28.80	0.144	0.33
88	62	63	82.06	-28.46	-81.91	28.80	0.144	0.33
89	63	64	80.14	-28.16	-80.08	28.32	0.069	0.16
90	63	64	80.14	-28.16	-80.08	28.32	0.069	0.16
91	64	65	60.02	-21.10	-59.91	21.35	0.108	0.25
92	64	65	60.02	-21.10	-59.91	21.35	0.108	0.25
93	65	66	59.91	-21.35	-59.84	21.53	0.077	0.18

94	65	66	59.91	-21.35	-59.84	21.53	0.077	0.18
							-----	-----
						Total:	35.336	115.04

Ssssc =

58.3078

>>

Annex 3: Load Flow Analysis and Optimization without Inclusion of SSSC in Standard IEEE 30-Bus System

MATLAB Command Window

Page 1

```
#####
####
-----
-----
                        Newton Raphson Loadflow Analysis
-----
-----
| Bus |   V   | Angle |   Injection   |   Generation   |   Load
|-----|-----|-----|-----|-----|-----|-----|-----|-----|
| No  |  pu   | Degree |  MW   | MVar  |  MW   | Mvar  |  MW   | MVar
MVar
-----
-----
  1   1.0600   0.0000  261.164   4.899  261.164   4.899   0.000
0.000
-----
  2   1.0330  -5.3686   18.300   17.442   40.000   30.142   21.700
12.700
-----
  3   1.0144  -7.9822   -2.400   -1.200   -0.000   0.000   2.400
1.200
-----
  4   1.0042  -9.6407   -7.600   -1.600   0.000   -0.000   7.600
1.600
-----
  5   1.0000 -14.4391  -94.200   17.721   0.000   36.721   94.200
19.000
-----
  6   1.0014 -11.3785   0.000   0.000   0.000   0.000   0.000
0.000
-----
  7   0.9930 -13.1723  -22.800  -10.900   -0.000   0.000   22.800
10.900
-----
  8   1.0000 -12.1211  -30.000   3.946   -0.000   33.946   30.000
30.000
-----
  9   1.0448 -14.4904   0.000   0.000   0.000   0.000   0.000
0.000
-----
```

```
10  1.0374  -16.1141  -5.800   17.000   -0.000   19.000   5.800 ↵
2.000
----- ↵
----
11  1.0820  -14.4904   0.000   19.354   0.000   19.354   0.000 ↵
0.000
----- ↵
----
12  1.0532  -15.3635 -11.200   -7.500   0.000   0.000   11.200 ↵
7.500
----- ↵
----
13  1.0710  -15.3635   0.000   13.621   0.000   13.621   0.000 ↵
0.000
----- ↵
----
14  1.0380  -16.2493  -6.200   -1.600   0.000   -0.000   6.200 ↵
1.600
----- ↵
----
15  1.0332  -16.3223  -8.200   -2.500   0.000   0.000   8.200 ↵
2.500
----- ↵
----
16  1.0392  -15.9543  -3.500   -1.800  -0.000   0.000   3.500 ↵
1.800
----- ↵
----
17  1.0326  -16.2753  -9.000   -5.800  -0.000   0.000   9.000 ↵
5.800
----- ↵
----
18  1.0224  -16.9510  -3.200   -0.900  -0.000  -0.000   3.200 ↵
0.900
----- ↵
----
19  1.0192  -17.1317  -9.500   -3.400   0.000   0.000   9.500 ↵
3.400
----- ↵
----
20  1.0230  -16.9350  -2.200   -0.700  -0.000  -0.000   2.200 ↵
0.700
----- ↵
----
21  1.0229  -16.6373 -17.500  -11.200   0.000  -0.000  17.500 ↵
11.200
----- ↵
----
22  1.0284  -16.4562   0.000   -0.000   0.000  -0.000   0.000 ↵
```

```

0.000
-----
23  1.0228  -16.6455  -3.200  -1.600  0.000  -0.000  3.200
1.600
-----
24  1.0161  -16.8222  -8.700  -2.400  -0.000  4.300  8.700
6.700
-----
25  1.0103  -16.3973  -0.000  0.000  -0.000  0.000  0.000
0.000
-----
26  0.9925  -16.8229  -3.500  -2.300  0.000  -0.000  3.500
2.300
-----
27  1.0152  -15.8722  0.000  0.000  0.000  0.000  0.000
0.000
-----
28  0.9978  -12.0054  0.000  0.000  0.000  0.000  0.000
0.000
-----
29  0.9952  -17.1221  -2.400  -0.900  -0.000  -0.000  2.400
0.900
-----
30  0.9836  -18.0197  -10.600  -1.900  0.000  0.000  10.600
1.900
-----
Total          17.764  35.783  301.164  161.983  283.400
126.200
-----
#####
#####
-----
Line FLOW and Losses
-----
|Line| |From|To |  P  |  Q  | From| To |  P  |  Q  |  Line Loss
| No  | |Bus |Bus|  MW  |  MVar | Bus | Bus|  MW  |  MVar |  MW  |

```

```

MVar |
----- ↵
-----
      1  1  2  177.762  -1.230  2  1  -172.362  17.401  5.400 ↵
16.172
----- ↵
-----
      2  1  3  83.402  11.387  3  1  -80.551  0.292  2.850 ↵
11.679
----- ↵
-----
      3  2  4  45.724  3.763  4  2  -44.599  -0.337  1.124 ↵
3.426
----- ↵
-----
      4  2  5  83.060  3.934  5  2  -77.368  1.211  0.784 ↵
2.250
----- ↵
-----
      5  2  6  61.878  1.349  6  2  -80.002  8.915  3.058 ↵
12.849
----- ↵
-----
      6  3  4  78.151  1.039  4  3  -59.792  4.980  2.086 ↵
6.329
----- ↵
-----
      7  4  6  70.164  -12.181  6  4  -69.565  14.263  0.598 ↵
2.082
----- ↵
-----
      8  4  12  44.203  -18.399  12  4  14.356  -11.518  0.158 ↵
0.399
----- ↵
-----
      9  5  7  -14.198  11.916  7  5  -37.156  2.462  0.376 ↵
1.153
----- ↵
-----
     10  6  7  37.532  -1.308  7  6  -29.396  5.266  0.107 ↵
0.375
----- ↵
-----
     11  6  8  29.503  -4.892  8  6  -27.920  23.046  0.000 ↵
2.442
----- ↵
-----
     12  6  9  27.920  -20.603  9  6  -15.918  7.584  -0.000 ↵
1.557

```

```

----- ↵
-----
  13  6  10  15.918  -6.027  10  6  -27.920  -6.607  0.000 ↵
0.666
----- ↵
-----
  14  6  28  18.484   0.826  28  6   -0.000  19.354  0.000 ↵
0.841
----- ↵
-----
  15  8  28  -0.604   1.270  28  8  -44.203  23.823  0.000 ↵
5.424
----- ↵
-----
  16  9  10  27.920   7.448  10  9   0.000  13.621  0.000 ↵
0.226
----- ↵
-----
  17  9  11   0.000 -18.689  11  9   -7.750  -2.382  0.075 ↵
0.156
----- ↵
-----
  18 10  17   5.077   3.944  17 10  -17.449  -6.867  0.218 ↵
0.430
----- ↵
-----
  19 10  20   8.743   3.279  20 10  -1.544  -0.777  0.061 ↵
0.128
----- ↵
-----
  20 10  21  18.336  11.626  21 10   -7.450  -3.723  0.006 ↵
0.006
----- ↵
-----
  21 10  22   5.882   3.366  22 10  -5.065  -3.912  0.015 ↵
0.034
----- ↵
-----
  22 12  13  -0.000 -13.394  13 12  -3.935  -1.888  0.044 ↵
0.090
----- ↵
-----
  23 12  14   7.825   2.538  14 12  -6.254  -1.934  0.006 ↵
0.013
----- ↵
-----
  24 12  15  17.668   7.296  15 12  -3.048  -1.021  0.015 ↵
0.031
----- ↵

```

```

-----
 25 12 16    7.511    3.850    16 12   -8.667   -3.110    0.076 ↵
0.169
----- ↵
-----
 26 14 15    1.550    0.782    15 14    6.467    2.410    0.012 ↵
0.032
----- ↵
-----
 27 15 18    6.298    2.023    18 15  -18.184  -11.297    0.152 ↵
0.328
----- ↵
-----
 28 15 23    4.495    3.120    23 15   -5.851   -3.302    0.031 ↵
0.064
----- ↵
-----
 29 16 17    3.950    1.923    17 16   -4.467   -3.063    0.000 ↵
0.000
----- ↵
-----
 30 18 19    3.054    1.034    19 18   -0.684   -0.097    0.028 ↵
0.057
----- ↵
-----
 31 19 20   -6.452   -2.379    20 19   -5.801   -3.225    0.049 ↵
0.076
----- ↵
-----
 32 21 23    0.684    0.097    23 21   -1.943   -1.545    0.008 ↵
0.016
----- ↵
-----
 33 22 24    5.851    3.302    24 22    0.968   -2.349    0.012 ↵
0.021
----- ↵
-----
 34 23 24    1.951    1.561    24 23   -3.500   -2.300    0.045 ↵
0.068
----- ↵
-----
 35 24 25   -0.956    2.370    25 24    4.535    0.060    0.022 ↵
0.042
----- ↵
-----
 36 25 26    3.545    2.368    26 25  -18.427   -0.622    0.000 ↵
1.282
----- ↵
-----

```

```

    37 25 27  -4.513  -0.018  27 25  0.605  -1.266  0.088 ↵
0.166
----- ↵
-----
    38 27 28  -17.822  5.203  28 27  17.822  -3.921  0.165 ↵
0.311
----- ↵
-----
    39 27 29   6.192  1.673  29 27  -6.104  -1.507  0.034 ↵
0.064
----- ↵
-----
    40 27 30   7.095  1.668  30 27  -6.930  -1.357  0.001 ↵
0.004
----- ↵
-----
    41 29 30   3.704  0.607  30 29  -3.670  -0.543  0.058 ↵
0.204
----- ↵
-----
      Total Loss                                17.764 ↵
71.661
----- ↵
-----
##### ↵
#####
Optimization without SSSC Started using MSSA
Modified Salp Swarm Optimizer
The best MSSA solution score is: 2.9841
Runing time: 2704.4748

varval_opt =

Columns 1 through 10

    1.1000  1.0979  1.0803  1.0976  1.1000  1.1000  80.0000  50.0000 ↵
35.0000  30.0000

Columns 11 through 20

    40.0000  0.9706  1.0722  1.0084  0.9801  0.0942  0.3151  0.1100 ↵
0.4984  0.2747

Columns 21 through 24

    0.3146  0.4974  0.3103  0.0124

fobjval =

```

2.9841

```
#####
####
-----
                                Newton Raphson Loadflow Analysis
-----
| Bus |   V   | Angle |   Injection   |   Generation   |   Load
|-----|-----|-----|-----|-----|-----|-----|-----|-----|
| No  |  pu   | Degree |  MW   | MVar  |  MW   | Mvar  |  MW   | MVar  |
|-----|-----|-----|-----|-----|-----|-----|-----|-----|
1    1.1000   0.0000   51.384  -10.694   51.384  -10.694   0.000
0.000
-----
2    1.0979  -0.7937   58.300   -3.870   80.000   8.830   21.700
12.700
-----
3    1.0912  -2.1184   -2.400   -1.200    0.000   0.000   2.400
1.200
-----
4    1.0884  -2.5035   -7.600   -1.600   -0.000   0.000   7.600
1.600
-----
5    1.0803  -4.5359  -44.200    3.436   50.000  22.436  94.200
19.000
-----
6    1.0852  -2.9884   -0.000   -0.000   -0.000  -0.000   0.000
0.000
-----
7    1.0760  -4.0887  -22.800  -10.900   -0.000  -0.000  22.800
10.900
-----
8    1.0876  -3.0000    5.000    4.932   35.000  34.932  30.000
30.000
-----
9    1.0903  -3.3165    0.000   -0.000    0.000  -0.000   0.000
0.000
```

```

0.000
----- ↵
----
 10  1.0718  -5.1159  -5.800  17.094  0.000  19.000  5.800 ↵
1.906
----- ↵
----
 11  1.1000  -0.3340  30.000  5.928  30.000  5.928  0.000 ↵
0.000
----- ↵
----
 12  1.0803  -3.6715  -11.200  -7.185  0.000  0.000  11.200 ↵
7.185
----- ↵
----
 13  1.1000  -0.9704  40.000  16.418  40.000  16.418  0.000 ↵
0.000
----- ↵
----
 14  1.0674  -4.6346  -6.200  -1.600  0.000  0.000  6.200 ↵
1.600
----- ↵
----
 15  1.0637  -4.8660  -8.200  -2.390  0.000  0.000  8.200 ↵
2.390
----- ↵
----
 16  1.0696  -4.5477  -3.500  -1.800  -0.000  -0.000  3.500 ↵
1.800
----- ↵
----
 17  1.0661  -5.1488  -9.000  -5.302  -0.000  -0.000  9.000 ↵
5.302
----- ↵
----
 18  1.0548  -5.6187  -3.200  -0.900  -0.000  -0.000  3.200 ↵
0.900
----- ↵
----
 19  1.0527  -5.8846  -9.500  -3.400  0.000  0.000  9.500 ↵
3.400
----- ↵
----
 20  1.0568  -5.7511  -2.200  -0.425  -0.000  -0.000  2.200 ↵
0.425
----- ↵
----
 21  1.0581  -5.5702  -17.500  -10.885  0.000  0.000  17.500 ↵
10.885

```

```

----- ↙
----
22  1.0657  -5.5571  0.000  0.000  0.000  0.000  0.000 ↙
0.000
----- ↙
----
23  1.0580  -5.5648  -3.200  -1.103  -0.000  -0.000  3.200 ↙
1.103
----- ↙
----
24  1.0568  -6.0745  -8.700  -2.090  -0.000  4.300  8.700 ↙
6.390
----- ↙
----
25  1.0617  -6.4157  -0.000  0.000  -0.000  0.000  0.000 ↙
0.000
----- ↙
----
26  1.0448  -6.8005  -3.500  -2.300  0.000  -0.000  3.500 ↙
2.300
----- ↙
----
27  1.0732  -6.3763  -0.000  -0.000  -0.000  -0.000  0.000 ↙
0.000
----- ↙
----
28  1.0814  -3.3134  0.000  0.000  0.000  0.000  0.000 ↙
0.000
----- ↙
----
29  1.0544  -7.4934  -2.400  -0.888  0.000  0.000  2.400 ↙
0.888
----- ↙
----
30  1.0435  -8.2917  -10.600  -1.900  -0.000  -0.000  10.600 ↙
1.900
----- ↙
----
Total          2.984  -22.624  286.384  101.149  283.400 ↙
123.773
----- ↙
##### ↙
##### ↙
----- ↙
-----
Line FLOW and Losses
----- ↙
-----

```

Line No	From Bus	To Bus	P MW	Q MVar	From Bus	To Bus	P MW	Q MVar	Line Loss MW
1	1	2	27.468	-4.862	2	1	-27.344	5.232	0.123

2	1	3	23.916	-0.169	3	1	-23.703	1.045	0.214

3	2	4	20.389	-0.418	4	2	-20.192	1.018	0.197

4	2	5	39.424	1.636	5	2	-21.252	-0.540	0.050

5	2	6	25.831	-0.147	6	2	-38.814	0.926	0.610

6	3	4	21.303	0.685	4	3	-25.510	1.123	0.322

7	4	6	24.561	1.453	6	4	-24.500	-1.242	0.061

8	4	12	9.284	3.513	12	4	5.412	-6.074	0.026

9	5	7	-5.386	6.140	7	5	-28.212	-2.662	0.185

10	6	7	28.397	3.230	7	6	1.102	5.852	0.004

11	6	8	-1.099	-5.840	8	6	-3.356	2.739	-0.000

```

-----
 12  6  9   3.356  -2.707   9  6  -7.243  -2.284  0.000 ↵
0.299
----- ↵
-----
 13  6 10   7.243   2.583  10  6 -33.356 -17.506  0.000 ↵
1.608
----- ↵
-----
 14  6 28  12.112   3.540  28  6  30.000   5.928  0.000 ↵
1.359
----- ↵
-----
 15  8 28   3.898   2.143  28  8  -9.284  -3.298  0.000 ↵
0.215
----- ↵
-----
 16  9 10  33.356  18.865  10  9  40.000  16.418  0.000 ↵
2.163
----- ↵
-----
 17  9 11 -30.000  -4.320  11  9  -8.226  -1.356  0.075 ↵
0.156
----- ↵
-----
 18 10 17   3.073   5.991  17 10 -20.001  -3.212  0.240 ↵
0.473
----- ↵
-----
 19 10 20   7.879   4.177  20 10  -2.018   0.251  0.075 ↵
0.158
----- ↵
-----
 20 10 21  17.379  11.568  21 10  -9.466  -1.204  0.008 ↵
0.007
----- ↵
-----
 21 10 22   6.468   1.239  22 10  -3.060  -5.958  0.026 ↵
0.060
----- ↵
-----
 22 12 13 -40.000 -14.254  13 12  -5.940   0.656  0.049 ↵
0.100
----- ↵
-----
 23 12 14   8.301   1.512  14 12  -7.108  -0.738  0.009 ↵
0.018
----- ↵
-----

```

```

    24 12 15    20.241    3.685    15 12    -3.899    0.180    0.014 ↵
0.027
----- ↵
-----
    25 12 16     9.541     1.363    16 12    -7.814    -4.033    0.065 ↵
0.145
----- ↵
-----
    26 14 15     2.026    -0.244    15 14     5.614     3.607    0.013 ↵
0.033
----- ↵
-----
    27 15 18     7.157     0.838    18 15   -17.247   -11.283    0.132 ↵
0.284
----- ↵
-----
    28 15 23     6.662    -0.268    23 15    -6.441    -1.183    0.027 ↵
0.057
----- ↵
-----
    29 16 17     5.966    -0.596    17 16    -6.623     0.347    0.000 ↵
0.000
----- ↵
-----
    30 18 19     3.908    -0.162    19 18     0.253    -0.398    0.039 ↵
0.079
----- ↵
-----
    31 19 20    -5.601    -3.580    20 19    -6.397    -1.115    0.043 ↵
0.068
----- ↵
-----
    32 21 23    -0.253     0.398    23 21    -3.157     1.079    0.013 ↵
0.027
----- ↵
-----
    33 22 24     6.441     1.183    24 22    -0.846     2.068    0.008 ↵
0.015
----- ↵
-----
    34 23 24     3.170    -1.052    24 23    -3.500    -2.300    0.041 ↵
0.061
----- ↵
-----
    35 24 25     0.854    -2.053    25 24     2.721     4.479    0.026 ↵
0.050
----- ↵
-----
    36 25 26     3.541     2.361    26 25   -12.089    -3.459    0.000 ↵

```

```
0.872
----- ↵
-----
 37 25 27 -2.695 -4.429 27 25 -3.887 -2.110 0.078 ↵
0.147
----- ↵
-----
 38 27 28 -15.976 -1.851 28 27 15.976 2.722 0.147 ↵
0.276
----- ↵
-----
 39 27 29 6.178 1.637 29 27 -6.100 -1.490 0.030 ↵
0.057
----- ↵
-----
 40 27 30 7.077 1.631 30 27 -6.930 -1.355 0.011 ↵
0.033
----- ↵
-----
 41 29 30 3.700 0.602 30 29 -3.670 -0.545 0.023 ↵
0.081
----- ↵
-----
      Total Loss                2.984 ↵
15.347
----- ↵
-----
##### ↵
#####
>>
```

```
0.872
----- ↵
-----
 37 25 27 -2.695 -4.429 27 25 -3.887 -2.110 0.078 ↵
0.147
----- ↵
-----
 38 27 28 -15.976 -1.851 28 27 15.976 2.722 0.147 ↵
0.276
----- ↵
-----
 39 27 29 6.178 1.637 29 27 -6.100 -1.490 0.030 ↵
0.057
----- ↵
-----
 40 27 30 7.077 1.631 30 27 -6.930 -1.355 0.011 ↵
0.033
----- ↵
-----
 41 29 30 3.700 0.602 30 29 -3.670 -0.545 0.023 ↵
0.081
----- ↵
-----
      Total Loss                2.984 ↵
15.347
----- ↵
-----
##### ↵
#####
>>
```

Annex 4: Load Flow Analysis and Optimization with Inclusion of SSSC in Standard IEEE 30-Bus System

MATLAB Command Window

Page 1

```
#####
###
-----
-----
                          Newton Raphson Loadflow Analysis
-----
-----
| Bus |   V   | Angle |   Injection   |   Generation   |   Load
|-----|-----|-----|-----|-----|-----|-----|-----|-----|
| No  |  pu   | Degree |   MW   |   MVar   |   MW   |   Mvar   |   MW   |
MVar |-----|-----|-----|-----|-----|-----|-----|-----|
-----
1   1.0600   0.0000   261.164   4.899   261.164   4.899   0.000
0.000
-----
2   1.0330  -5.3686   18.300   17.442   40.000   30.142   21.700
12.700
-----
3   1.0144  -7.9822   -2.400   -1.200   -0.000   0.000   2.400
1.200
-----
4   1.0042  -9.6407   -7.600   -1.600   0.000   -0.000   7.600
1.600
-----
5   1.0000 -14.4391  -94.200   17.721   0.000   36.721   94.200
19.000
-----
6   1.0014 -11.3785   0.000   0.000   0.000   0.000   0.000
0.000
-----
7   0.9930 -13.1723  -22.800  -10.900   -0.000   0.000   22.800
10.900
-----
8   1.0000 -12.1211  -30.000   3.946   -0.000   33.946   30.000
30.000
-----
9   1.0448 -14.4904   0.000   0.000   0.000   0.000   0.000
0.000
-----
-----
```

```
10  1.0374  -16.1141  -5.800  17.000  -0.000  19.000  5.800 ✓
2.000
----- ✓
----
11  1.0820  -14.4904   0.000  19.354   0.000  19.354   0.000 ✓
0.000
----- ✓
----
12  1.0532  -15.3635 -11.200  -7.500   0.000   0.000  11.200 ✓
7.500
----- ✓
----
13  1.0710  -15.3635   0.000  13.621   0.000  13.621   0.000 ✓
0.000
----- ✓
----
14  1.0380  -16.2493  -6.200  -1.600   0.000  -0.000   6.200 ✓
1.600
----- ✓
----
15  1.0332  -16.3223  -8.200  -2.500   0.000   0.000   8.200 ✓
2.500
----- ✓
----
16  1.0392  -15.9543  -3.500  -1.800  -0.000   0.000   3.500 ✓
1.800
----- ✓
----
17  1.0326  -16.2753  -9.000  -5.800  -0.000   0.000   9.000 ✓
5.800
----- ✓
----
18  1.0224  -16.9510  -3.200  -0.900  -0.000  -0.000   3.200 ✓
0.900
----- ✓
----
19  1.0192  -17.1317  -9.500  -3.400   0.000   0.000   9.500 ✓
3.400
----- ✓
----
20  1.0230  -16.9350  -2.200  -0.700  -0.000  -0.000   2.200 ✓
0.700
----- ✓
----
21  1.0229  -16.6373 -17.500 -11.200   0.000  -0.000  17.500 ✓
11.200
----- ✓
----
22  1.0284  -16.4562   0.000  -0.000   0.000  -0.000   0.000 ✓
```

```

0.000
-----
----
23  1.0228  -16.6455  -3.200  -1.600  0.000  -0.000  3.200
1.600
-----
----
24  1.0161  -16.8222  -8.700  -2.400  -0.000  4.300  8.700
6.700
-----
----
25  1.0103  -16.3973  -0.000  0.000  -0.000  0.000  0.000
0.000
-----
----
26  0.9925  -16.8229  -3.500  -2.300  0.000  -0.000  3.500
2.300
-----
----
27  1.0152  -15.8722  0.000  0.000  0.000  0.000  0.000
0.000
-----
----
28  0.9978  -12.0054  0.000  0.000  0.000  0.000  0.000
0.000
-----
----
29  0.9952  -17.1221  -2.400  -0.900  -0.000  -0.000  2.400
0.900
-----
----
30  0.9836  -18.0197  -10.600  -1.900  0.000  0.000  10.600
1.900
-----
----
Total          17.764  35.783  301.164  161.983  283.400
126.200
-----
#####
#####
-----
Line FLOW and Losses
-----
|Line| |From|To |  P  |  Q  | From| To |  P  |  Q  |  Line Loss
| No  ||Bus |Bus|  MW  |  MVar | Bus | Bus|  MW  |  MVar |  MW  |

```

MVar									
1	1	2	177.762	-1.230	2	1	-172.362	17.401	5.400
16.172									
2	1	3	83.402	11.387	3	1	-80.551	0.292	2.850
11.679									
3	2	4	45.724	3.763	4	2	-44.599	-0.337	1.124
3.426									
4	2	5	83.060	3.934	5	2	-77.368	1.211	0.784
2.250									
5	2	6	61.878	1.349	6	2	-80.002	8.915	3.058
12.849									
6	3	4	78.151	1.039	4	3	-59.792	4.980	2.086
6.329									
7	4	6	70.164	-12.181	6	4	-69.565	14.263	0.598
2.082									
8	4	12	44.203	-18.399	12	4	14.356	-11.518	0.158
0.399									
9	5	7	-14.198	11.916	7	5	-37.156	2.462	0.376
1.153									
10	6	7	37.532	-1.308	7	6	-29.396	5.266	0.107
0.375									
11	6	8	29.503	-4.892	8	6	-27.920	23.046	0.000
2.442									
12	6	9	27.920	-20.603	9	6	-15.918	7.584	-0.000
1.557									

```

-----
-----
  13  6  10  15.918  -6.027  10  6  -27.920  -6.607  0.000 ✓
0.666
-----
-----
  14  6  28  18.484   0.826  28  6   -0.000  19.354  0.000 ✓
0.841
-----
-----
  15  8  28  -0.604   1.270  28  8  -44.203  23.823  0.000 ✓
5.424
-----
-----
  16  9  10  27.920   7.448  10  9   0.000  13.621  0.000 ✓
0.226
-----
-----
  17  9  11   0.000 -18.689  11  9   -7.750  -2.382  0.075 ✓
0.156
-----
-----
  18  10 17   5.077   3.944  17  10  -17.449  -6.867  0.218 ✓
0.430
-----
-----
  19  10 20   8.743   3.279  20  10  -1.544  -0.777  0.061 ✓
0.128
-----
-----
  20  10 21  18.336  11.626  21  10  -7.450  -3.723  0.006 ✓
0.006
-----
-----
  21  10 22   5.882   3.366  22  10  -5.065  -3.912  0.015 ✓
0.034
-----
-----
  22  12 13  -0.000 -13.394  13  12  -3.935  -1.888  0.044 ✓
0.090
-----
-----
  23  12 14   7.825   2.538  14  12  -6.254  -1.934  0.006 ✓
0.013
-----
-----
  24  12 15  17.668   7.296  15  12  -3.048  -1.021  0.015 ✓
0.031
-----
-----

```

```

-----
 25 12 16    7.511    3.850    16 12    -8.667    -3.110    0.076 ✘
0.169
----- ✘
-----
 26 14 15    1.550    0.782    15 14     6.467     2.410    0.012 ✘
0.032
----- ✘
-----
 27 15 18    6.298    2.023    18 15   -18.184   -11.297    0.152 ✘
0.328
----- ✘
-----
 28 15 23    4.495    3.120    23 15    -5.851    -3.302    0.031 ✘
0.064
----- ✘
-----
 29 16 17    3.950    1.923    17 16    -4.467    -3.063    0.000 ✘
0.000
----- ✘
-----
 30 18 19    3.054    1.034    19 18    -0.684    -0.097    0.028 ✘
0.057
----- ✘
-----
 31 19 20   -6.452   -2.379    20 19    -5.801    -3.225    0.049 ✘
0.076
----- ✘
-----
 32 21 23    0.684    0.097    23 21    -1.943    -1.545    0.008 ✘
0.016
----- ✘
-----
 33 22 24    5.851    3.302    24 22     0.968    -2.349    0.012 ✘
0.021
----- ✘
-----
 34 23 24    1.951    1.561    24 23    -3.500    -2.300    0.045 ✘
0.068
----- ✘
-----
 35 24 25   -0.956    2.370    25 24     4.535     0.060    0.022 ✘
0.042
----- ✘
-----
 36 25 26    3.545    2.368    26 25   -18.427    -0.622    0.000 ✘
1.282
----- ✘
-----

```

```

    37 25 27  -4.513  -0.018  27 25  0.605  -1.266  0.088 ✎
0.166
----- ✎
-----
    38 27 28 -17.822  5.203  28 27  17.822  -3.921  0.165 ✎
0.311
----- ✎
-----
    39 27 29  6.192  1.673  29 27  -6.104  -1.507  0.034 ✎
0.064
----- ✎
-----
    40 27 30  7.095  1.668  30 27  -6.930  -1.357  0.001 ✎
0.004
----- ✎
-----
    41 29 30  3.704  0.607  30 29  -3.670  -0.543  0.058 ✎
0.204
----- ✎
-----
    Total Loss 17.764 ✎
71.661
----- ✎
-----
##### ✎
#####
Optimization with SSSC Started using MSSA
Modified Salp Swarm Optimizer
The best MSSA solution score is: 2.9814
Runing time: 2461.3007

ans =

    Columns 1 through 10

    1.1000  1.0976  1.0798  1.0970  1.1000  1.1000  80.0000  50.0000 ✎
35.0000  30.0000

    Columns 11 through 20

    40.0000  1.0141  0.9687  0.9904  0.9711  0.0496  0.0397  0.0187 ✎
0.0113  0.0011

    Columns 21 through 24

    0.0454  0.0176  0.0453  0.0063

ans =

```

18

ans =

0.0976 -1.3093

fobjval =

2.9814

```
#####
###
-----
-----
                          Newton Raphson Loadflow Analysis
-----
-----
| Bus |   V   | Angle |   Injection   |   Generation   |   Load
| No  |  pu   | Degree |  MW   |  MVar  |  MW   |  Mvar  |  MW   |
MVar |
-----
-----
  1   1.1000   0.0000   51.154   -9.302   51.154   -9.302   0.000
0.000
-----
  2   1.0976  -0.7874   58.300   -3.133   80.000    9.567   21.700
12.700
-----
  3   1.0897  -2.0877   -2.400   -1.200   -0.000   -0.000    2.400
1.200
-----
  4   1.0867  -2.4654   -7.600   -1.600    0.000    0.000    7.600
1.600
-----
  5   1.0798  -4.5305  -44.200    3.364   50.000   22.364   94.200
19.000
-----
  6   1.0847  -2.9813   -0.000   -0.000   -0.000   -0.000    0.000
0.000
-----
```

7	1.0755	-4.0827	-22.800	-10.900	0.000	0.000	22.800	10.900
8	1.0870	-2.9917	5.000	4.680	35.000	34.680	30.000	30.000
9	1.0829	-3.3039	0.000	0.000	0.000	0.000	0.000	0.000
10	1.0823	-5.0860	-5.800	17.050	0.000	19.000	5.800	1.950
11	1.1000	-0.3013	30.000	9.807	30.000	9.807	0.000	0.000
12	1.0860	-3.5123	-11.831	-7.663	-0.000	0.000	11.831	7.663
13	1.1000	-0.8253	40.000	11.970	40.000	11.970	0.000	0.000
14	1.0768	-4.5640	-6.200	-1.600	-0.000	-0.000	6.200	1.600
15	1.0760	-4.9688	-7.580	-2.265	-0.000	-0.000	7.580	2.265
16	1.0772	-4.4402	-3.500	-1.800	0.000	0.000	3.500	1.800
17	1.0755	-5.0879	-9.000	-5.789	0.000	0.000	9.000	5.789
18	1.0665	-5.6558	-3.200	-0.900	-0.000	0.000	3.200	0.900

19	1.0639	-5.8865	-9.500	-3.400	0.000	0.000	9.500	3.400
20	1.0677	-5.7403	-2.200	-0.699	-0.000	-0.000	2.200	0.699
21	1.0688	-5.5487	-17.500	-11.155	-0.000	-0.000	17.500	11.155
22	1.0761	-5.5198	-0.000	-0.000	-0.000	-0.000	0.000	0.000
23	1.0687	-5.5506	-3.200	-1.582	0.000	-0.000	3.200	1.582
24	1.0671	-6.0273	-8.700	-2.355	-0.000	4.300	8.700	6.655
25	1.0720	-6.3576	-0.000	-0.000	-0.000	-0.000	0.000	0.000
26	1.0552	-6.7349	-3.500	-2.300	0.000	0.000	3.500	2.300
27	1.0833	-6.3163	0.000	0.000	0.000	0.000	0.000	0.000
28	1.0809	-3.3068	0.000	-0.000	0.000	0.000	0.000	0.000
29	1.0647	-7.4118	-2.400	-0.894	0.000	0.000	2.400	0.894
30	1.0539	-8.1947	-10.600	-1.900	0.000	0.000	10.600	1.900
Total			2.743	-23.565	286.154	102.386	283.411	

125.951

```
-----
#####
#####
```

Line FLOW and Losses

```
-----
|Line| |From|To |   P   |   Q   | From| To |   P   |   Q   |   Line Loss
| No  ||Bus |Bus|  MW   |  MVar | Bus | Bus|  MW   |  MVar |  MW   |
MVar  |
-----
```

Line No	From Bus	To Bus	P (MW)	Q (MVar)	From Bus	To Bus	P (MW)	Q (MVar)	Line Loss (MW)
1	1	2	27.399	-4.360	2	1	-27.277	4.725	0.122
									0.366
2	1	3	23.755	0.721	3	1	-23.544	0.144	0.211
									0.865
3	2	4	20.287	0.549	4	2	-20.092	0.045	0.195
									0.594
4	2	5	39.434	1.747	5	2	-21.095	-1.434	0.050
									0.143
5	2	6	25.856	0.013	6	2	-38.823	0.817	0.610
									2.565
6	3	4	21.144	1.578	4	3	-25.533	0.965	0.322
									0.978
7	4	6	25.083	-1.912	6	4	-25.020	2.134	0.064
									0.222
8	4	12	8.504	0.379	12	4	5.403	-6.107	0.026
									0.067
9	5	7	-5.377	6.173	7	5	-28.203	-2.630	0.185

```

0.569
-----
10  6  7  28.388  3.199  7  6  1.101  5.640  0.003 ✓
0.012
-----
11  6  8  -1.098  -5.629  8  6  -3.136  -0.887  0.000 ✓
0.019
-----
12  6  9   3.136   0.906  9  6  -8.005  -0.326  -0.000 ✓
0.295
-----
13  6 10   8.005   0.621 10  6 -33.136  -0.085  -0.000 ✓
1.712
-----
14  6 28  12.121   3.543 28  6  30.000   9.807   0.000 ✓
1.031
-----
15  8 28   3.899   2.100 28  8  -8.504  -0.223   0.000 ✓
0.156
-----
16  9 10  33.136   1.116 10  9  40.000  11.970   0.000 ✓
2.017
-----
17  9 11 -30.000  -8.095 11  9  -8.280   0.225   0.073 ✓
0.151
-----
18 10 17   2.950   7.571 17 10 -18.642  -6.236   0.007 ✓
0.534
-----
19 10 20   8.092   3.969 20 10  -2.065   1.838   0.075 ✓
0.158
-----
20 10 21  17.774  11.409 21 10  -9.596  -0.132   0.015 ✓
0.013
-----
21 10 22   6.525   1.325 22 10  -2.932  -7.523   0.028 ✓
0.066

```

```

-----
-----
  22 12 13 -40.000 -9.953 13 12 -6.068 1.734 0.046 ✓
0.094
-----
-----
  23 12 14 8.353 -0.074 14 12 -6.894 -1.216 0.008 ✓
0.016
-----
-----
  24 12 15 18.648 6.770 15 12 -3.686 -0.301 0.013 ✓
0.026
-----
-----
  25 12 16 9.671 0.289 16 12 -8.027 -3.824 0.065 ✓
0.145
-----
-----
  26 14 15 2.080 -1.825 15 14 5.827 3.126 0.018 ✓
0.048
-----
-----
  27 15 18 6.940 1.310 18 15 -17.641 -11.124 0.133 ✓
0.285
-----
-----
  28 15 23 6.187 0.823 23 15 -6.498 -1.269 0.028 ✓
0.057
-----
-----
  29 16 17 6.096 -1.668 17 16 -6.154 -0.755 0.000 ✓
0.000
-----
-----
  30 18 19 3.694 0.316 19 18 -0.141 0.031 0.034 ✓
0.068
-----
-----
  31 19 20 -5.814 -3.099 20 19 -6.454 -1.201 0.044 ✓
0.068
-----
-----
  32 21 23 0.141 -0.031 23 21 -3.083 0.883 0.012 ✓
0.024
-----
-----
  33 22 24 6.498 1.269 24 22 -0.829 2.051 0.008 ✓
0.014
-----
-----

```

```

-----
 34 23 24    3.095    -0.859    24 23    -3.500    -2.300    0.040 ✘
0.060
----- ✘
-----
 35 24 25    0.837    -2.037    25 24     2.737     4.459    0.025 ✘
0.049
----- ✘
-----
 36 25 26    3.540     2.360    26 25   -12.098    -3.462    0.000 ✘
0.841
----- ✘
-----
 37 25 27   -2.711    -4.411    27 25    -3.888    -2.067    0.076 ✘
0.144
----- ✘
-----
 38 27 28  -15.986     1.109    28 27    15.986    -0.268    0.144 ✘
0.271
----- ✘
-----
 39 27 29     6.176     1.637    29 27    -6.099    -1.493    0.030 ✘
0.056
----- ✘
-----
 40 27 30     7.074     1.628    30 27    -6.930    -1.357    0.011 ✘
0.033
----- ✘
-----
 41 29 30     3.699     0.599    30 29    -3.670    -0.543    0.023 ✘
0.081
----- ✘
-----
      Total Loss                                2.743 ✘
14.913
----- ✘
-----
##### ✘
#####
>>

```

REFERENCES

- [1] A. Jain, L. K. Yadav, A. Omer, and S. Bhullar, “Analysis of effectiveness of SSSC in transmission network using PI controlled technique,” *Energy Procedia*, vol. 117, pp. 699–707, Jun. 2017
- [2] G. Bone, R. Mihalič, “Modelling the SSSC Device in the Power Flow Problem as Power Injections Regulated According to First Order Sensitivity”, *Deregulated Electricity Market Issues in South Eastern Europe*, 2015.
- [3] N. Grudinin, “Reactive power optimization using successive quadratic programming method,” *IEEE Trans. Power Syst.*, vol. 13, no. 4, pp. 1219–1225, Nov. 1998.
- [4] R. Jamal, B. Men, and N. H. Khan, “A novel nature inspired meta-heuristic optimization approach of GWO optimizer for optimal reactive power dispatch problems,” *IEEE Access*, vol. 8, pp. 202596–202610, 2020.
- [5] R. Katuri, A. Jayalaxmi, G. Yesuratnam, and D. Yeddanapaalli, “Genetic algorithm optimization of generator reactive power,” *AASRI Procedia*, vol. 2, pp. 192–198, Jan. 2012.
- [6] K. B. O. Medani, S. Sayah, and A. Bekrar, “Whale optimization algorithm based optimal reactive power dispatch: A case study of the Algerian power system,” *Electr. Power Syst. Res.*, vol. 163, pp. 696–705, Oct. 2018.
- [7] M. Ebeed, A. Ali, M. I. Mosaad, and S. Kamel, “An improved lightning attachment procedure optimizer for optimal reactive power dispatch with uncertainty in renewable energy resources,” *IEEE Access*, vol. 8, pp. 168721–168731, 2020.
- [8] A. Amin, S. Kamel, and M. Ebeed, “Optimal reactive power dispatch considering SSSC using grey wolf algorithm,” in *Proc. 18th Int. Middle East Power Syst. Conf. (MEPCON)*, Dec. 2016, pp. 780–785.
- [9] S. Mirjalili a,*, A. H. Gandomi b,f, S. Z. Mirjalili c, S. Saremi a, H. Faris d, S. M. Mirjalili e, “Salp Swarm Algorithm: A bio-inspired optimizer for engineering design problems”, © 2017 Elsevier Ltd.
- [10] N. H. Khan, Y. Wang, D. Tian, R. Jamal, S. Kamel and M. Ebeed “Optimal Siting and Sizing of SSSC Using Modified Salp Swarm Algorithm Considering Optimal Reactive Power Dispatch Problem,” *IEEE Access*, 2021.3061503
- [11] N. H. Khan, Y. Wang, D. Tian, M. A. Z. Raja, R. Jamal, and Y. Muhammad, “Design of fractional particle swarm optimization gravitational search algorithm for optimal reactive power dispatch problems,” *IEEE Access*, vol. 8, pp. 146785–146806, 2020.
- [12] S. Mouassa and T. Bouktir, “Multi-objective ant lion optimization algorithm to solve large-scale multi-objective optimal reactive power dispatch problem,” *COMPEL Int. J. Comput. Math. Electr. Electron. Eng.*, vol. 38, no. 1, pp. 304–324, Jan. 2019.
- [13] H. Faris, M. M. Mafarja, A. A. Heidari, I. Aljarah, A. M. Al-Zoubi, S. Mirjalili, and H. Fujita, “An efficient binary salp swarm algorithm with crossover scheme for feature selection problems,” *Knowl-Based Syst.*, vol. 154, pp. 43–67, Aug. 2018.
- [14] R. A. Ibrahim, A. A. Ewees, D. Oliva, M. Abd Elaziz, and S. Lu, “Improved salp swarm algorithm based on particle swarm optimization for feature selection,” *J. Ambient Intell. Humanized Comput.*, vol. 10, no. 8, pp. 3155–3169, Aug. 2019.

- [15] L. Abualigah, M. Shehab, M. Alshinwan, and H. Alabool, “Salp swarm algorithm: A comprehensive survey,” *Neural Comput. Appl.*, vol. 32, pp. 11195–11215, Nov. 2019, doi: 10.1007/s00521-019-04629-4.
- [16] P. P. Biswas, P. Arora, R. Mallipeddi, P. N. Suganthan, and B. K. Panigrahi, “Optimal placement and sizing of FACTS devices for optimal power flow in a wind power integrated electrical network,” *Neural Comput. Appl.*, pp. 1–22, Nov. 2020, doi: 10.1007/s00521-020-05453-x.
- [17] G. Tu, Y. Li, and J. Xiang, “Analysis, control and optimal placement of static synchronous compensator with/without battery energy storage,” *Energies*, vol. 12, no. 24, p. 4715, Dec. 2019.
- [18] M. Ebeed, A. Ali, M. I. Mosaad, and S. Kamel, “An improved lightning attachment procedure optimizer for optimal reactive power dispatch with uncertainty in renewable energy resources,” *IEEE Access*, vol. 8, pp. 168721–168731, 2020.
- [19] G. Chen, L. Liu, Z. Zhang, and S. Huang, “Optimal reactive power dispatch by improved GSA-based algorithm with the novel strategies to handle constraints,” *Appl. Soft Comput.*, vol. 50, pp. 58–70, Jan. 2017.
- [20] S. Kamel, F. Jurado, and Z. Chen, “Power flow control for transmission networks with implicit modeling of static synchronous series compensator,” *Int. J. Electr. Power Energy Syst.*, vol. 64, pp. 911–920, Jan. 2015.

[IOEGC15] Editor Decision



IOEGC15 Publication Committee <conference-noreply@ioe.edu.np>

to me, Jeetendra, Akhileshwar, Prabhat ▾

Mon, Jun 10, 9:12AM (2 days ago)

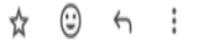

Priyanka Karna; Jeetendra Chaudhary, Akhileshwar Mishra, Prabhat Kumar Pankaj;

We have reached a decision regarding your submission to 15th IOE Graduate Conference, "OPTIMAL SITING AND SIZING OF SSSC IN INPS USING MODIFIED SALP SWARM ALGORITHM CONSIDERING OPTIMAL REACTIVE POWER DISPATCH PROBLEM".

Our decision is to: **Accept Submission**

Optimal siting and sizing of SSSC in INPS using Modified Salp Swarm Algorithm considering Optimal Reactive Power Dispatch Problem

Priyanka Karna ^a, Jeetendra Chaudhary ^b, Akhileshwor Mishra ^c, Prabhat Pankaj ^d,

^a Department of Electrical Engineering, Pulchowk Campus, Institute of Engineering, Tribhuvan University, Nepal

^b Department of Electrical Engineering, Pulchowk Campus, Institute of Engineering, Tribhuvan University, Nepal

^c Department of Electrical Engineering, Pulchowk Campus, Institute of Engineering, Tribhuvan University, Nepal

^d Nepal Electricity Authority, Nepal

✉ ^a priyankakarn03@gmail.com

Abstract

Effective coordination between power generation and demand is vital for maximizing efficiency, especially with the increasing demand for electrical energy. Flexible AC Transmission System (FACTS) devices, like the Static Synchronous Series Compensator (SSSC), enhance transmission efficiency by improving power transfer capacity and stability. Integrating SSSC presents challenges due to nonlinear functions, complicating the Optimal Reactive Power Dispatch (ORPD) problem. To address this, a Modified Salp Swarm Algorithm efficiently determines the optimal location and rating of SSSC, comparing results with the IEEE 30-bus system. Our approach aims to minimize power losses, voltage deviations, and improve the voltage profile, demonstrating its effectiveness in optimizing power system operation with SSSC controllers. After solving the ORPD problem and load flow analysis, initial line losses of 119.108 MW (5.8% of total load) reduced to 35.336 MW (1.72% of total load) after including SSSC in INPS. The optimal SSSC size is 58.307 MVA, located on line Lahan to Kusaha, resulting in significant power loss reduction and voltage profile improvement.

Keywords

Flexible alternating current transmission systems, static synchronous series compensator, Optimal reactive power dispatch, Integrated Nepalese Power System

1. Introduction

In the sector of electrical power systems, managing transmission networks efficiently has become increasingly crucial with rising energy demands. Flexible Alternating Current Transmission Systems (FACTS) devices [12] are indispensable tools for enhancing grid controllability, stability, and efficiency [11]. Among these devices, the Static Synchronous Series Compensator (SSSC) is notable for optimizing reactive power dispatch within power systems. By inserting controllable voltage in series with transmission lines, the SSSC regulates active and reactive power flow, ensuring voltage stability and enhancing transmission capacity [4]. SSSC is modelled within the load flow problem by representing it as power injections at the nodes [5] [9] of the line where it is installed. These power injections, which represent the SSSC, are used as

inputs in a power flow calculation. [1]

The optimal management of reactive power resources, known as Optimal Reactive Power Dispatch (ORPD) [5], is essential for maintaining system integrity and efficiency. This involves determining settings for reactive power sources to uphold voltage levels within limits while minimizing power losses [9] [1]. However, as power systems evolve, the ORPD problem becomes more complex [7], requiring innovative optimization techniques [2].

This paper is using an optimization algorithm [3] based on the Modified Salp Swarm Algorithm (MSSA) [10] to address the ORPD problem [8] and determine optimal SSSC locations and ratings. MSSA adjusts control variables iteratively to optimize the specified objective function for power system operation on the Integrated Nepal Power System (INPS) and comparison with the IEEE 30-bus system

[6] demonstrate the algorithm's efficacy in minimizing losses, voltage deviations, and enhancing stability. Integration of SSSC within the optimization framework promises significant improvements in system performance, offering a cost-effective solution for power system optimization.

2. Approach

The main objective of this paper is to find the optimal size and the location of the SSSC in the INPS using Modified Salp Swarm Algorithm. To optimize the power losses and voltage deviation reduction SSSC model is developed with Optimal Reactive Power Dispatch solution. Load flow analysis is carried out in INPS without SSSC and with SSSC and result is compared with the IEEE 30-Bus system.

2.1 SSSC Modeling and Formulation

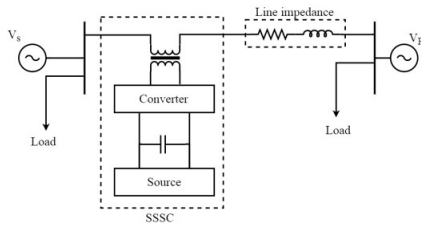

Figure 1: Schematic diagram of SSSC

The SSSC is modeled in load flow analysis as power injections at the nodes of the transmission line where it is installed, rather than directly incorporating it into calculations. Initially, load flow analysis is performed without considering the SSSC, yielding a mismatch vector indicating deviation from desired conditions. The power injections representing the SSSC are adjusted iteratively to minimize this mismatch vector. Convergence is reached when the mismatch vector becomes sufficiently small, indicating steady-state conditions satisfying SSSC requirements. The SSSC can be modeled as a voltage source in series with impedance.

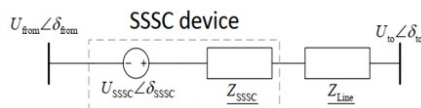

Figure 2: The SSSC Device Normally Modelled

This directly simplifies into:

$$Z_{Total} = Z_{SSSC} + Z_{Line} \quad (1)$$

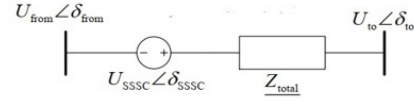

Figure 3: SSSC equivalent branch, summing impedences

The Norton equivalent of figure 3 we obtained is shown in figure 4:

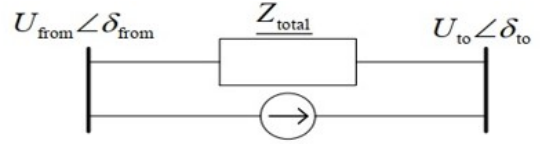

Figure 4: SSSC equivalent branch, Norton equivalent

$$I_G = \frac{U_{SSSC} \angle \delta_{SSSC}}{Z_{total}} \quad (2)$$

The latter can be restated in terms of power injections in the following ways:

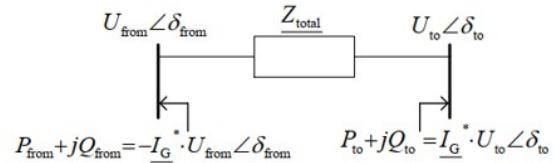

Figure 5: SSSC equivalent nodal power injections at ends of line of insertion

$$P_{from} + jQ_{from} = -I_G * U_{from} \angle \delta_{from} \quad (3)$$

$$P_{to} + jQ_{to} = I_G * U_{to} \angle \delta_{to} \quad (4)$$

The power injections will model an SSSC device. The parameters of the SSSC device, U_{SSSC} and δ_{SSSC} , can then be calculated from the injected powers and the voltages and angles at the bus of SSSC device as:

$$U_{SSSC} \angle \delta_{SSSC} = Z_{total} * I_G \quad (5)$$

2.2 Optimal Reactive Power Dispatch (ORPD) Problem Formulation for Different Objective Functions

The aim of the ORPD problem is to find the values of control variables that minimize the objective function while satisfying certain equality and inequality conditions. The control variables include various parameters that can be adjusted, such as generator

powers and bus voltages. The dependent variables are the outcomes or results of the optimization, representing aspects like power generation, bus voltages, and the impact of the SSSC. The formulation of these equations are from the reference [2].

The ORPD problem minimizes an objective function while adhering to equality and inequality constraints. The objective is to optimize system performance by adjusting control variables while ensuring operational constraints are met. The independent variables include factors such as generated power, voltages, and reactive powers, while dependent variables encompass various system parameters like generated power at the slack bus and power flow in transmission lines. Constraints are categorized as equality and inequality, ensuring specific conditions are met precisely and imposing limits on variables, respectively. Ultimately, ORPD aims to enhance the efficiency and stability of power systems.

2.2.1 Minimization of Power Losses and Voltage Deviations

The minimization of active power losses and voltage deviations in single objective function can be formulated as:

$$F = \alpha \sum_{i=1}^{NL} P_{losses} + \beta \sum_{i=1}^{NL} [V_i - V_{ref}] \quad (6)$$

Here, F represents the objective function, where α and β are weighting factors representing the relative importance of minimizing power losses and voltage deviations, respectively. NL denotes the number of transmission lines, P_{losses} represents active power losses, V_i represents the voltage magnitude at bus i, and V_{ref} is the reference voltage, commonly set to 1. This objective function integrates the goals of reducing both power losses and voltage deviations, allowing for a unified optimization approach that balances both objectives according to the specified weighting factors.

2.2.2 Constraints

1. Equality Constraints

These constraints represent the balanced load flow equations as:

$$P_{Gi} - P_{Di} = \sum_{j=1}^{NB} |V_i||V_j||Y_{ij}| \cos(\theta_{ij} - \delta_{ij}) \quad (7)$$

$$Q_{Gi} - Q_{Di} = \sum_{j=1}^{NB} |V_i||V_j||Y_{ij}| \sin(\theta_{ij} - \delta_{ij}) \quad (8)$$

1. Inequality Constraints

These constraints which represent the operating limits of system component include:

$$P_{Gi}^{min} \leq P_{Gi} \leq P_{Gi}^{max} \quad i = 1, 2, \dots, NG \quad (9)$$

$$V_{Gi}^{min} \leq V_{Gi} \leq V_{Gi}^{max} \quad i = 1, 2, \dots, NG \quad (10)$$

$$Q_{Gi}^{min} \leq Q_{Gi} \leq Q_{Gi}^{max} \quad i = 1, 2, \dots, NG \quad (11)$$

$$V_{Li}^{min} \leq V_{Li} \leq V_{Li}^{max} \quad i = 1, 2, \dots, NPQ \quad (12)$$

$$V_{se}^{max} \leq V_{se} \leq V_{se}^{min} \quad (13)$$

$$\theta_{se}^{max} \leq \theta_{se} \leq \theta_{se}^{min} \quad (14)$$

The system constraints which added to the objective function are taken into consideration by using the penalty factors related the constraints. Thereby, the objective function can be formulated as:

$$\begin{aligned} F_g(x, u) = & Fi(x, u) + eG(PG1 - P_{G1}^{lim})^2 + \\ & eQ \sum_{i=1}^{NPV} (Q_{Gi} - Q_{Gi}^{lim})^2 + ev \sum_{i=1}^{NPQ} (V_{Li} - V_{Li}^{lim})^2 + \\ & es \sum_{i=1}^{NLT} (S_{Li} - S_{Li}^{lim})^2 + eF(V_{se} - V_{se}^{lim})^2 + \\ & et(\theta_{se} - \theta_{se}^{lim})^2 \end{aligned} \quad (15)$$

2.3 The Modified Salp Swarm Algorithm (MSSA)

1. Mathematical Model of MSSA

In the Salp Swarm Algorithm (SSA), inspired by the behavior of salps in deep oceans, the population is divided into two groups: leaders and followers. The leader, positioned at the front of the chain, guides the swarm, while the rest of the salps act as followers, following either the leader directly or indirectly. This swarming behavior, resembling the formation of salp chains, aids in efficient movement and potentially in locating food sources.

In SSA, the position of salps is represented in an n-dimensional search space, where n corresponds to the number of variables in a given problem. This position information is stored in a two-dimensional matrix known as Z_n , facilitating the exploration of the search space by the salps.

To update the position of the leader the following equation is proposed:

$$Z_n^i = \begin{cases} Z_{LD} + C_1(u_n - l_n)c_2 + l_n c_3 & \geq 0 \\ Z_{LD} + C_1(u_n - l_n)c_2 + l_n c_3 & < 0 \end{cases} \quad (16)$$

where, Z_n^i and Z_{LD} represent the leader position and food source position, respectively. U_n and l_n are the upper and lower limits in nth dimension of search space.

$$C_1 = 2e^{-\left(-\frac{4a}{A}\right)} \quad (17)$$

In order to change the position of followers, the following expression is used.

$$Z_n^m = \frac{1}{2}ce^2 + v_0e \quad (18)$$

Where, $m \geq 2$, $c = \frac{v_{final}}{v_0}$ and $v = \frac{z-z_0}{e}$. The simulation time is depending on the iterations and the conflict between iteration is equal to 1 while considering $v_0 = 0$, the Equation (16) will be as followed.

$$Z_n^m = \frac{1}{2}(Z_n^m + Z_n^{m-1}) \quad (19)$$

The MSSA is proposed to overcome the shortages of the conventional SSA which include its tendency to local optima. and stagnation for some cases. Two search strategies are presented for enhancing capability of the conventional SSA. The modification in SSA is utilized for boosting the exploration process by updating the locations of salps using the Levy flight distribution (LFD) to aid population to find new areas to overcome its stagnation. While the second modification depends upon modifying and updating the locations of salps in the spiral path around the best solution to enhance its exploitation. The first modification which based on the LFD is expressed as follows.

$$Z_{n-new}^m = Z_n^m + \infty + Levy(\beta) \quad (20)$$

Where ∞ refers to a step size parameter which is assigned as follows.

$$\infty + Levy(\beta) \sim 0.01 \frac{u}{|v|^{\frac{1}{\beta}}} (Z_n^m - Z_{LD}) \quad (21)$$

where u and v are determined using (26) and (27) as follows:

$$u \sim N(0, \phi_u^2), v \sim N(0, \phi_v^2) \quad (22)$$

$$\phi_u = \left[\frac{\Gamma(1 + \beta)x \sin(\Pi x \frac{\beta}{2})}{\Gamma[\frac{1+\beta}{2}]x\beta} \right]^{\frac{1}{\beta}}, \phi_v = 1 \quad (23)$$

where Γ represents the standard gamma function. The second modification is based on modifying the locations of salps in the spiral path around the best solution which can be expressed as follows:

$$Z_{n-new}^m = |Z_{LD} - Z_n^m| e^{bt} \cos(2\pi t) + Z_n^m \quad (24)$$

where b denotes a constant to describe the logarithmic spiral shape. To balance the exploration and the exploitation process an adaptive operator k is utilized to achieve this task.

$$K(t) = k_{min} + \left(\frac{k_{max} - k_{min}}{T_{max}} \right) * t \quad (25)$$

where, k_{max} and k_{min} are the maximum and the minimum k limits. Finally, it is worth mentioned that searching capability of the MSSA is improved by enhancing the exploration phase using the LFD by applying Eq. (18) at the first iteration when the value of k is small while the exploitation phase is enhanced using the variable bandwidth transition by applying Eq. (22) at the final iteration when the value of k is large.

2.4 Single Line Diagram of Integrated Nepalese Power System

The Integrated Nepal Power System (INPS) is the primary electrical grid network that connects power generation facilities, transmission lines, substations, and distribution networks across Nepal into a unified system. It serves as the backbone of the country's electricity infrastructure, facilitating the transmission and distribution of power from various sources to consumers throughout Nepal. INPS has 400 kV, 220 kV, 132 kV, 66 kV, 33 kV and 11 kV transmission

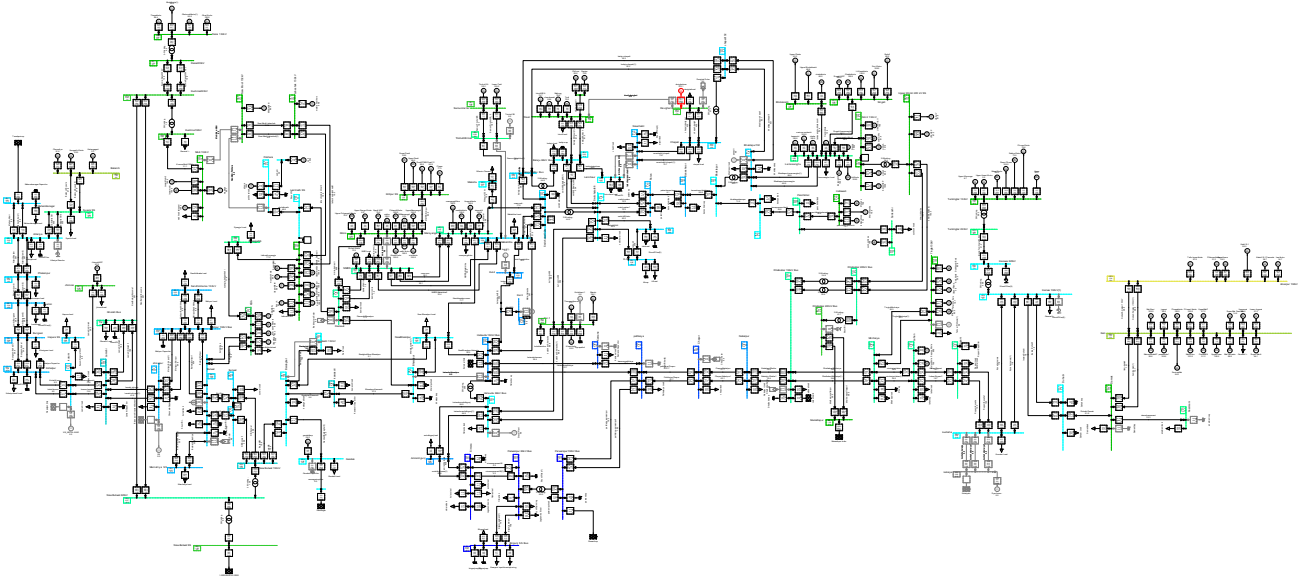

Figure 6: Integrated Nepalese Power System

network in which 132 kV network has mostly used in transmission network in all over Nepal. In INPS Dhalkebar and Muzaffarpur are the maximum capacity substation which has 400 kV double circuit line having highest transmission capacity. The total installed capacity in INPS is 3320 MW but the peak load is 2010 MW. In dry season generation does not meet the demand so power is imported from Indian grid through Dhalkebar and Muzaffarpur line but in wet season power is surplus so it is exported to India. Nepal has Marsyandi, Middle Marsyangdi, Kaligandaki and Chameliya as highest capacity PROR. Kulekhani-I, Kulekhani-II and Kulekhani-III and only storage type of plant in all over Nepal. Mostly generation are in hilly region and load are mostly in terai region due to which there congestion in transmitting the line and disturbance in voltage in the line.

2.5 A. Flow Chart of MSSA to solve ORPD problem with Optimal inclusion of SSSC

Hence, the Modified Salp Swarm Algorithm (MSSA) outlined in the flowchart presents a novel approach to optimizing power systems, leveraging the collective behavior of salp populations. By iteratively updating the positions of salps based on fitness evaluations and incorporating randomness to maintain diversity, the algorithm aims to find optimal solutions for power system operation.

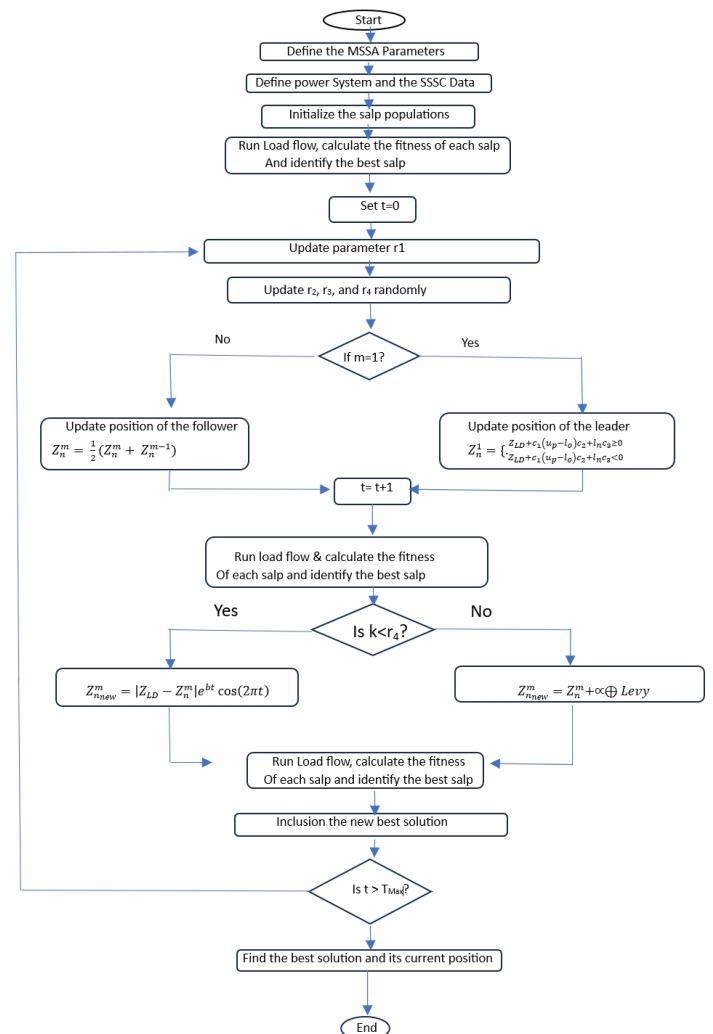

Figure 7: Flowchart of MSSA to solve ORPD problem with optimal inclusion of SSSC.

3. Result

In order to achieve the objective, coding was done in MATLAB programming for the INPS. ORPD problem was solved and load flow analysis was done using MSSA algorithm. Coding for Optimal placement of SSSC was done with the optimal calculation of optimal size and placement of SSSC. The line losses were calculated and was found to be 35.336 MW after the inclusion of SSSC in INPS which is very then the loss without SSSC in INPS which was 119.108 MW. The optimal size of SSSC was 58.307 MVA with the optimal location in line Lahan to Kusaha. The line from the Bus Lahan to the Bus Kusaha is most overloaded line in INPS.

These are the figures of convergence performance of MSSA for power losses and voltage profile with base case and optimized case in INPS with and without inclusion of SSSC in the system.

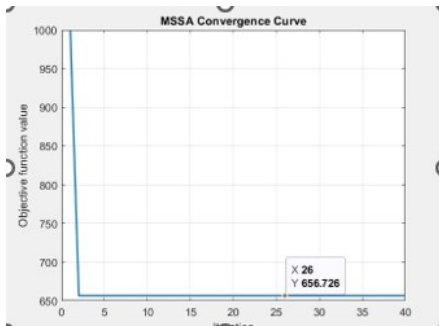

Figure 8: Convergence Performance of MSSA for Power Losses Minimization without Inclusion the SSSC on INPS

Here, figure 8 explains to the performance of the MSSA in minimizing power losses within the INPS, specifically without considering the inclusion of SSSC.

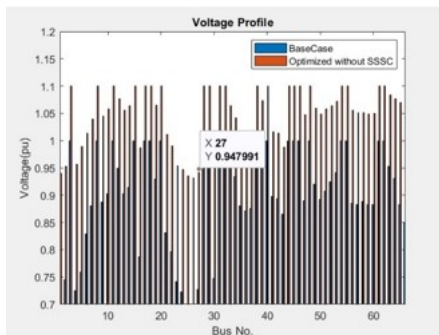

Figure 9: Voltage Profile without Inclusion the SSSC on INPS

Here, figure 9 explains the improvement of voltage profile in optimized case then the base case after performing load flow analysis without considering the inclusion of SSSC on INPS.

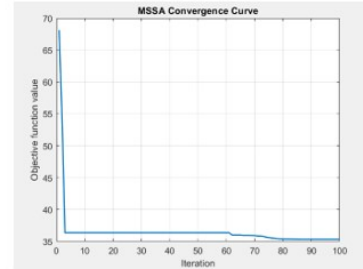

Figure 10: Convergence Performance of MSSA for Power Losses Minimization with Inclusion the SSSC on INPS

Here, figure 10 explains to the performance of the MSSA in minimizing power losses within the INPS, specifically with considering the inclusion of SSSC.

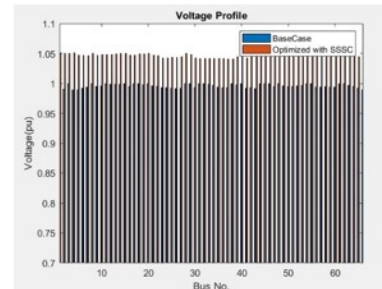

Figure 11: Voltage Profile with Inclusion the SSSC on INPS

Here, figure 11 explains the improvement of voltage profile in optimized case then the base case after performing load flow analysis on INPS with considering the inclusion of SSSC.

After comparing the figure 11 with figure 9, we see that voltage profile has been improved much after inclusion of SSSC in the system then the system without SSSC. Hence, line losses have been decreased.

Since for the actual scenario of Nepal, there are most ROR and PROR plant and the data has been taken for the wet condition. So, we cannot optimize the power and cannot fix its value in such as we cannot stop the power plant to decrease the losses, the supply cannot be stopped and power should be exported. Power plant must run in full condition. For that case

the value of voltage was not above 0.95 p.u. after optimization and there was no feasible solution within those constraints. Therefore, constraints were relaxed and taken to 0.9 p.u. and was able to get the solution.

Also, the result was compared with and without SSSC in IEEE 30-Bus system and found that there was decrease in the line losses which was 2.743 p.u. with SSSC and 2.984 p.u. without SSSC. After optimization we get the optimum placement of SSSC in the Line 18 which is the branch 12-15 with the optimal size of SSSC as 72.39 MVA

Now the convergence performance of MSSA for power loss minimization without and with inclusion of SSSC and its voltage profile can be shown and compared as follows:

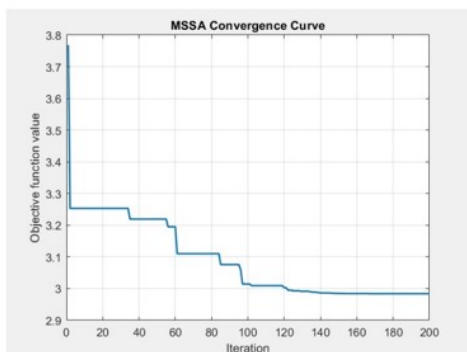

Figure 12: Convergence Performance of MSSA for Power Losses Minimization without Inclusion the SSSC on IEEE 30-Bus System

Here, figure 12 explains to the performance of the MSSA in minimizing power losses within the IEEE 30-Bus system, specifically without considering the inclusion of SSSC.

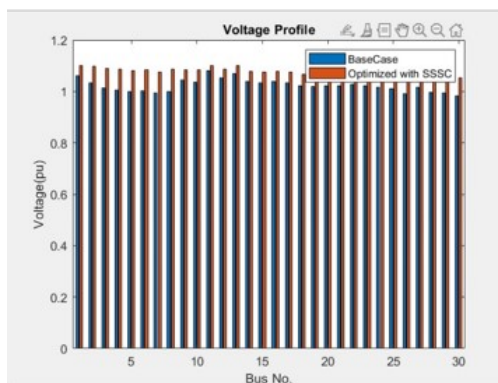

Figure 13: Voltage Profile without Inclusion the SSSC on IEEE 30-Bus System

Here, figure 13 explains the improvement of voltage

profile in optimized case then the base case after performing load flow analysis without considering the inclusion of SSSC on IEEE 30-Bus system.

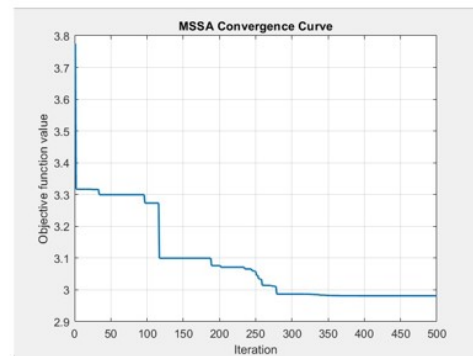

Figure 14: Convergence Performance of MSSA for Power Losses Minimization with Inclusion the SSSC on IEEE 30-Bus System

Here, figure 14 explains to the performance of the MSSA in minimizing power losses within the IEEE 30-Bus system, specifically with considering the inclusion of SSSC.

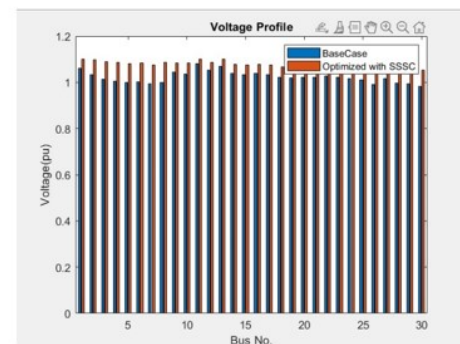

Figure 15: Voltage Profile with Inclusion the SSSC on IEEE 30-Bus System

Here, figure 15 explains the improvement of voltage profile in optimized case then the base case after performing load flow analysis on IEEE 30-Bus system with considering the inclusion of SSSC. After comparing the figure 15 with figure 13, we see that voltage profile has been improved much after inclusion of SSSC in the system then the system without SSSC. Hence, we became able to verify the result of INPS with the test result of IEEE 30-Bus system.

4. Conclusion

The objective of research is the optimal placement and size of SSSC and reduction of power losses after the placement. We see in INPS, there is reduction of

power losses and improvement in voltage profile after optimization and inclusion of SSSC in the system. The similar work was done in IEEE 30-Bus system and got the similar result.

Acknowledgments

The authors are grateful to the assistance provided by personnels of Load Dispatch Centre from Nepal Electricity Authority in terms of data throughout this research.

References

- [1] A. Amin, S. Kamel, and M. Ebeed. Optimal reactive power dispatch considering sssc using grey wolf algorithm. In *2016 Eighteenth International Middle East Power Systems Conference (MEPCON)*, pages 780–785. IEEE, 2016.
- [2] G. Bone and R. Mihalič. Modelling the sssc device in the power flow problem as power injections regulated according to first order sensitivity. *Engineering and Industry Series, Deregulated Electricity Market Issues in South Eastern Europe*, 2015:80–85, 2015.
- [3] R. A. Ibrahim, A. A. Ewees, D. Oliva, M. Abd Elaziz, and S. Lu. Improved salp swarm algorithm based on particle swarm optimization for feature selection. *Journal of Ambient Intelligence and Humanized Computing*, 10:3155–3169, 2019.
- [4] A. Jain, L. K. Yadav, A. Omer, and S. Bhullar. Analysis of effectiveness of sssc in transmission network using pi controlled technique. *Energy Procedia*, 117:699–707, 2017.
- [5] S. Kamel, F. Jurado, and Z. Chen. Power flow control for transmission networks with implicit modeling of static synchronous series compensator. *International Journal of Electrical Power & Energy Systems*, 64:911–920, 2015.
- [6] N. H. Khan, Y. Wang, D. Tian, R. Jamal, S. Kamel, and M. Ebeed. Optimal siting and sizing of sssc using modified salp swarm algorithm considering optimal reactive power dispatch problem. *IEEE Access*, 9:49249–49266, 2021.
- [7] N. H. Khan, Y. Wang, D. Tian, M. A. Z. Raja, R. Jamal, and Y. Muhammad. Design of fractional particle swarm optimization gravitational search algorithm for optimal reactive power dispatch problems. *IEEE Access*, 8:146785–146806, 2020.
- [8] K. Lee, Y. Park, and J. Ortiz. A united approach to optimal real and reactive power dispatch. *IEEE Transactions on power Apparatus and systems*, (5):1147–1153, 1985.
- [9] I. Marouani, T. Guesmi, H. Hadj Abdallah, and A. Ouali. Optimal reactive power dispatch with sssc device using nsgaii approach. *International Journal of Computer Science and Network Security, IJCSNS*, 10(7):58–68, 2010.
- [10] S. Mirjalili, A. H. Gandomi, S. Z. Mirjalili, S. Saremi, H. Faris, and S. M. Mirjalili. Salp swarm algorithm: A bio-inspired optimizer for engineering design problems. *Advances in engineering software*, 114:163–191, 2017.
- [11] E. Naderi, M. Pourakbari-Kasmaei, and H. Abdi. An efficient particle swarm optimization algorithm to solve optimal power flow problem integrated with facts devices. *Applied Soft Computing*, 80:243–262, 2019.
- [12] X.-P. Zhang, C. Rehtanz, and B. Pal. *Flexible AC transmission systems: modelling and control*. Springer Science & Business Media, 2012.

Optimal Siting and Sizing of SSSC In INPS Using Modified Salp Swarm Algorithm Considering Optimal Reactive Power Dispatch

ORIGINALITY REPORT

9%

SIMILARITY INDEX

PRIMARY SOURCES

- 1 Noor Habib Khan, Yong Wang, De Tian, Raheela Jamal, Salah Kamel, Mohamed Ebeed. "Optimal Siting and Sizing of SSSC Using Modified Salp Swarm Algorithm Considering Optimal Reactive Power Dispatch Problem", IEEE Access, 2021 81 words — 1%

Crossref
- 2 hdl.handle.net 48 words — 1%

Internet
- 3 Khalid. H. Mohamed, K. S. Rama Rao. "Intelligent optimization techniques for optimal power flow using Interline Power Flow Controller", 2010 IEEE International Conference on Power and Energy, 2010 43 words — 1%

Crossref
- 4 Mohamed Ebeed, Shimaa Ali, Ahmed M. Kassem, Mohamed Hashem et al. "Solving stochastic optimal reactive power dispatch using an Adaptive Beluga Whale optimization considering uncertainties of renewable energy resources and the load growth", Ain Shams Engineering Journal, 2024 30 words — < 1%

Crossref
- 5 Alex Chamba, Carlos Barrera-Singaña, Hugo Arcos. "Optimal Reactive Power Dispatch in 25 words — < 1%

Electric Transmission Systems Using the Multi-Agent Model with Volt-VAR Control", Energies, 2023

Crossref

6 Worawat Nakawiro, Istvan Erlich. "Voltage security assessment and control system using a hybrid intelligent method", 2009 IEEE Bucharest PowerTech, 2009 23 words — < 1%

Crossref

7 link.springer.com 21 words — < 1%

Internet

8 Noor Habib Khan, Yong Wang, De Tian, Raheela Jamal, Salah Kamel, Mohamed Ebeed. "Optimal siting and sizing of SSSC Using Modified Salp Swarm Algorithm Considering Optimal Reactive Power Dispatch Problem", IEEE Access, 2021 19 words — < 1%

Crossref

9 techscience.com 18 words — < 1%

Internet

10 Mostafa Abdo, Salah Kamel, Mohamed Ebeed, Juan Yu, Francisco Jurado. "Solving Non-Smooth Optimal Power Flow Problems Using a Developed Grey Wolf Optimizer", Energies, 2018 17 words — < 1%

Crossref

11 mafadoc.com 17 words — < 1%

Internet

12 Ban H. Alajrash, Mohamed Salem, Mahmood Swadi, Tomonobu Senjyu, Mohamad Kamarol, Saad Motahhir. "A comprehensive review of FACTS devices in modern power systems: Addressing power quality, optimal 16 words — < 1%

placement, and stability with renewable energy penetration",
Energy Reports, 2024

Crossref

-
- 13 Ajay Shah, Sanjaya Neupane, Kamal Darlami. "Impact Study of the Hetauda-Dhalkewar-Inaruwa Transmission Line on the Operation of Integrated Nepal Power System", Advances in Engineering and Technology: An International Journal, 2023 15 words — < 1%

Crossref

-
- 14 Oveis Abedinia, Ali Ghasemi-Marzbali, Mohammad Shafei, Mehdi Bagheri. "A Modified Salp Swarm Algorithm: An Application for Reactive Power Dispatch Problem", 2022 IEEE International Conference on Environment and Electrical Engineering and 2022 IEEE Industrial and Commercial Power Systems Europe (EEEIC / I&CPS Europe), 2022 15 words — < 1%

Crossref

-
- 15 Benjamin L. Delay, Maziar Moaveni, John M. Hart, Phil Sharpe, Erol Tutumluer. "Evaluating Railroad Ballast Degradation Trends Using Machine Vision and Machine Learning Techniques", Geotechnical Frontiers 2017, 2017 12 words — < 1%

Crossref

-
- 16 D. F. Lopes, J. L. Marques, E. A. Castro. "Chapter 22 A MCDA/GIS-Based Approach for Evaluating Accessibility to Health Facilities", Springer Science and Business Media LLC, 2021 12 words — < 1%

Crossref

-
- 17 Khaled Ben Oualid Medani, Samir Sayah. "Optimal reactive power dispatch using particle swarm optimization with time varying acceleration coefficients", 2016 8th International Conference on Modelling, Identification and Control (ICMIC), 2016 11 words — < 1%

Crossref

- 18 Jaganathan, S., and S. Palaniswami. "Application of refined bacterial foraging algorithm technique to control of optimal power dispatch with interline power flow controller", Journal of Vibration and Control, 2013. 10 words — < 1%
Crossref
-
- 19 ispranproceedings.elpub.ru 10 words — < 1%
Internet
-
- 20 www.frontiersin.org 10 words — < 1%
Internet
-
- 21 TEJASWITA KHOBARAGADE, k t Chaturvedi. "Comparative Analysis of Evolutionary Techniques for Economical Load Dispatch in a 6-Unit Thermal Power System", Research Square Platform LLC, 2023 9 words — < 1%
Crossref Posted Content
-
- 22 Thomas Poirié, Thomas Schmitt, Etienne Bousser, Richard Vernhes, Ludvik Martinu, Jolanta Ewa Klemberg-Sapieha. "Hybrid organic/inorganic nanolaminate structures with enhanced tribo-mechanical properties for optical applications", Surface and Coatings Technology, 2017 9 words — < 1%
Crossref
-
- 23 coek.info 9 words — < 1%
Internet
-
- 24 repository.its.ac.id 9 words — < 1%
Internet
-
- 25 shop.tarjomeplus.com 9 words — < 1%
Internet
-
- 26 A. Cano, F. Jurado. "Optimum location of biomass-1% fuelled gas turbines in an electric system", 2006 8 words — <

27 B. Tyagi, S.C. Srivastava. "A method for optimal placement of reactive sources & reactive power procurement in competitive electricity markets", 2006 IEEE Power India Conference, 2006 8 words — < 1%

28 Mahmoud Zadehbagheri, Rahim Ildarabadi, Abdol 8 words — < 1% majid Javadian. "Optimal Power Flow in the Presence of HVDC Lines Along with Optimal Placement of FACTS in order to Power System Stability Improvement in Diferent Conditions: Technical and Economic Approach", IEEE Access, 2023

29 S. Surender Reddy, P. R. Bijwe. "Efciency Improvements in Meta-Heuristic Algorithms to Solve the Optimal Power Flow Problem", International Journal of Emerging Electric Power Systems, 2016 8 words — < 1%

30 Shelly Vadhera, Shreya Mahajan. "Optimal allocation of dispersed generation unit in a network system", 2016 International Conference on Microelectronics, Computing and Communications (MicroCom), 2016 8 words — < 1%

31 Yiyang Qiao, Fan Hu, Wen Xiong, Zihao Guo, Xiaoguang Zhou, Yajun Li. "Multi-objective optimization of integrated energy system considering installation confguration", Energy, 2023 8 words — < 1%

32 ejtas.com 8 words — < 1%

33 journals.semnan.ac.ir

Internet

8 words — < 1%

34 www.mdpi.com

Internet

8 words — < 1%

EXCLUDE QUOTES ON

EXCLUDE SOURCES OFF

EXCLUDE BIBLIOGRAPHY ON

EXCLUDE MATCHES OFF