

**MIGRATION INDUCED SOCIAL CHANGE IN
AN URBAN SETTING**

A Study of Chhorepatan, Pokhara

**A Thesis Submitted to the Faculty of
Humanities and Social Sciences, Department of
Sociology/Anthropology In partial fulfillment for the Degree of
Master of
Arts in Sociology**

Krishna Kumari Basnet

Roll No. 101/064

T.U. Regd. No. 6-1-48-1937-2002

**Tribhuvan University
Department of Sociology/ Anthropology
Prithivi Narayan Campus,
Pokhara**

2015

LETTER OF RECOMMENDATION

It is with great pleasure that I recommend the approval of the thesis entitled **Migration Induced Social Change in an Urban Setting** *A Study of Chhorepatan, Pokhara* completed by **Krishna Kumari Basnet** under my supervision for partial fulfillment of the requirements for Master of Arts in Sociology. Therefore, this thesis is recommended for its evaluation.

Date : 2071/12/13

Amrit Kumar Bhandari
Lecturer
Department of Sociology/Anthropology
Prithwi Narayan Campus
Pokhara, Nepal

LETTER OF APPROVAL

This is to certify that the thesis submitted by **Krishna Kumari Basnet** entitled **Migration Induced Social Change in an Urban Setting** *A Study of Chhorepatan, Pokhara* has been approved by this Department in the prescribed format of Humanities and Social Sciences.

EVALUATION COMMITTEE

.....

Shanti Bhushal

Head of the Department

.....

Prof. Dr. Lekhnath Bhattarai

External

.....

Amrit Kumar Bhandari

Supervisor

Date: 2071/12/30

ACKNOWLEDGEMENT

I wish to thank various people for their contribution to this project special thanks should be given to my supervisor Amrit Kumar Bhandari, for his guidance, positive response and useful critiques through out the research work as well as in the process of writing this thesis. I am equally grateful to the department of sociology/Anthropology Prithvi Narayan Campus for providing permission to write dissertation in this title **Migration Induced Social Change in an Urban Setting** *A study of chhorepatan, pokhara*. Similarly, the respected personalities and well wishers of Department deserve thanks.

Another special thanks are given to Mr. Pradip Thapa assisting me during my field works and making my dissertation presentable.

I express my heartfelt thanks to my spouse Laxman Thapa for his love, support and encouragement for me during my survey and I also thankful to my parents, family and friends for their support and encouragement through my work on this thesis.

Similarly, I would like to express my sincere thanks to all the people of Chhorepatan for their cordial support and co-operation during my field.

I have felt spengthened a lot from the cordial co-operation of all above mentioned people and parties. But I consider myself immature in the context of dissertation related works. Therefore, I might have made several mistakes during my research works. In fact, no one is perfect and perfection is an illusion that can never be translated into reality. Thus, I entirely bear all the errors happened during the research work.

Date : 2071/12/27

Krishna Kumari Basnet

TABLE OF CONTENTS

<i>LETTER OF RECOMMENDATION</i>	<i>II</i>
<i>LETTER OF APPROVAL</i>	<i>III</i>
<i>ACKNOWLEDGEMENT</i>	<i>IV</i>
<i>TABLE OF CONTENTS</i>	<i>V</i>
<i>LIST OF TABLES</i>	<i>VII</i>
<i>LIST OF FIGURES</i>	<i>VIII</i>
CHAPTER I : INTRODUCTION	1-5
1.1 Background of the Study	1
1.2 Statement of the Problem	3
1.3 Objective of the Study	3
1.4 Significant of the Study	4
1.5 Limitation of the Study	4
1.6 Organization of the Study	4
CHAPTER II : LITERATURE REVIEW	6-16
2.1 Theoretical Overview	6
2.1.1 Migration as Social Interaction	6
2.1.2 Structural Functionalism	8
2.1.3 Urbanisation	9
2.2 Review of Previous studies	12
2.3 Research Gap	16
CHAPTER III : RESEARCH METHODS	17-22
3.1 Rational of the Selection of the Study area	17
3.2 Research design	17
3.3 Nature and sources of data	18
3.4 Universe and Sampling	18

3.5	Data collection Technique	19
3.5.1	Questionnaire	19
3.5.2	Interview	19
3.5.3	Observation	20
3.6	Reliability and validity of the data	20
3.7	Operational Definition and measurement of selected concepts/ variables	20
3.8	Data processing and analysis	21

CHAPTER IV : STUDY AREA AND THE RESPONDENTS 22-30

4.1	Study Area	22
4.1.1	General Introduction of Pokhara	22
4.1.2	Brief Introduction to Chhorepatan	23
4.2	Selected Demographic Characteristics of Respondents	23
4.2.1	Caste/Ethnicity of Respondents	23
4.2.2	Distribution of Family size of Respondents	25
4.2.3	Age group of the respondents	26
4.2.4	Distribution of migrants family by sex	27
4.2.5	Educational Status of Respondents Family	28
4.2.6	Religion of the Respondents	29
4.2.7	Occupational characteristic of Migrants	30

CHAPTER V : SOCIAL INTERACTION BETWEEN MIGRANTS AND LOCAL PEOPLE 31-38

5.1	Origin of Migrants	31
5.2	Reason for Choosing Chhorepatan of Migrants	32
5.3	First Reaction of local resident towards migrants	33
5.4	Involvement of in Social Activities on Chhorepatan	34
5.5	Migrants working post in the organization	35

5.6	Migrants participation in different activities of tole development	36
5.7	Heard your opinion in your organization	37
5.8	Change in Chhorepatan after migration	38

**CHAPTER VI : PATTERN OF CULTURAL EXCHANGE BETWEEN
THE MIGRANTS AND THE LOCALS 39-52**

6.1	Differences of the respondents from local people	39
6.2	Migrants way of performing birth, death and marriage rituals	40
6.3	Migrants get invitation from locals in their rituals	41
6.4	Type of participation played in locals Rituals	42
6.5	Type of participation by locals in their rituals	43
6.6	Type of participation of people of the place of origin	43
6.7	Feeling in the activities of death ceremony in this place	45
6.8	State of reciprocal exchange	46
6.9	The main things/goods exchanged	47
6.10	Migrants food habit	48
6.11	Migrants celebrate birthday	49
6.12	State of traditional culture	50
6.13	Way of observing festivals in the festivals	51
6.14	Differences between societies of before migration and this	51

CHAPTER VII : SUMMARY AND CONCLUSION 53-55

7.1	Summary of findings	53
7.2	Conclusion	54

References

LIST OF TABLE

Table Headings	Page
4.1 Distribution of the Respondents by caste/Ethnicity	24
4.2 Distribution of the Respondents by family	25
4.3 Distribution of the Respondents by age	26
4.4 Distribution of migrants family by sex	27
4.5 Distribution of the Respondents	28
4.6 Distribution of Respondents by religion	29
4.7 Occupational Characteristic of Migrants	30
5.1 Distribution of origin of migrants	31
5.2 Distribution of origin of migrants	32
5.3 First Reaction of local resident towards you	33
5.4 Migrants Engaged organization and activities in Chhorepatan	34
5.5 Migrants working post in the organization (N=18)	35
5.6 Migrants working post in the organization	36
5.7 Heard your opinion in your organization	37
5.8 Change in Chhorepatan after migration	38
6.1 Difference from local people	39
6.2 Migrants way of performing birth, death and marriage rituals	40
6.3 Migrants get invitation from locals in their rituals	41
6.4 Type of participation by respondents in locals Rituals	42
6.5 Type of participation by locals in respondents rituals	43
6.6 Type of participation by locals in their rituals	44
6.7 Feeling in the activities of death ceremony in this place	45
6.8 State of reciprocal exchange	46
6.9 The main things/goods exchanged	47
6.10 Migrants food habit	48
6.11 Migrants celebrate birthday	49
6.12 State of traditional culture	50
6.13 Way of observing festivals	51
6.14 State of traditional culture	52

LIST OF FIGURE

Figure Headings	Page
4.1 Distribution of the Respondents by caste/Ethnicity	24
4.2 Distribution of the Respondents by family	25
4.3 Distribution of migrants family by sex	27
4.4 Migrants Engaged organization and activities in Chhorepatan	29
5.1 Distribution of origin of migrants	31
5.2 Distribution of origin of migrants	32
5.3 First Reaction of local resident towards you	33
5.4 Distribution of Respondents by religion	34
5.5 Migrants working post in the organization	36
5.6 Heard your opinion in your organization	37
6.1 Difference from local people	39
6.2 Migrants way of performing birth, death and marriage rituals	40
6.3 Migrants get invitation from locals in their rituals	41
6.4 Type of participation by respondents in locals Rituals	42
6.5 Type of participation by locals in their rituals	43
6.6 Feeling in the activities of death ceremony in this place	45
6.7 State of reciprocal exchange	46
6.8 The main things/goods exchanged	47
6.9 Migrants food habit	48
6.10 Migrants celebrate birthday	49
6.11 State of traditional culture	50

CHAPTER I

INTRODUCTION

1.1 Background of the Study

Migration is the physical movement of people within and between social systems. The sociological study of migration focuses on "Push factors" and "Pull factors" (conditions that cause people to leave one area and be attracted to another) as well as international demands for labour and the shift of capital across national boundaries. The definition of the word migration can be the movement of people from one place to another with the intention of settling temporarily or permanently in the new location. The phenomenon of migration is as old as the history of mankind. People have moved across continents, nations in search of better resources (New Era : 1981).

Migration as a permanent or semi permanent change of residence by an individual or group of people. Migration means physical movement of people from one place to another for the betterment of life. Rural urban migration is the migration of people from rural areas into cities. In this study I have used migration as both temporarily and permanent movement of people (individual and whole family) from rural areas to urban areas and have involved in some informal works in the city (John and et.al 2000 : c.f. Timilsina, 2007).

Internal migration is not a new phenomenon in Nepal. It has long been used as a strategy for making a living by the Nepalese population and especially rural to rural migration has played a part in the Eastern Hill Region of Nepal. But the increased demand for income generating activities and interest in

education has also initiated rural urban migration (Subedi 2006). Urban centers across the border in India have been popular destinations, but increasing numbers are moving to Kathmandu, and the urbanization of degree is escalating dramatically. Especially the increased quality of higher education in the capital area leads to increased migration, and the number of internal educational migrants are similarly on the rise (Shakya, 2009).

Migration is the 3rd component of population change. The other two being mortality and fertility the nature of migration as a factor affecting population size is different from that of mortality and fertility. Migratory movements are therefore a product of the social, cultural, economic, political and physical circumstances in which individuals and societies find them (Bhende and Kanitkar, 2004). of the three major components of population change, migration is the most difficult to conceptualize and measure (Jones, 1981). The difficulties in conceptualizing and measuring the phenomenon of migration arise because unlike fertility and mortality, migration is not just an unequivocal biological event but a physical and social transaction (Zelinsky, 1971). The fact that a migrant is a person who travels is the only unambiguous element in the entire subject (Barelay, 1958). In neoclassical laissez faire equilibrium theory, migration is regarded as an adjustment mechanism which directs the spatial economy to a state of equilibrium (Chandna 1999).

In the context of migration it may have impacts on national identity interpretation and cohesion this refers to how migration affects neighbourhoods and is defined by people's perceptions of how people get along with each other in their local area or neighborhood.

1.2 Statement of the Problem

Most of the developing countries like Nepal have been suffering from the burning problem of population, migration. It creates a number of social, economic, demographic and political problems for the country. In the previous century the people migrated from west to east but at present period the people migrates from north to south from the mountains to the terai region.

Chhorepatan is one of most urbanized place in Pokhara. It is so due to the high rate of migration. People from different places migrate to this area. Due to the high rate as migration the requirements needed for the people are also high in number, which resultant development needed for the people are almost fulfilled in his area. The basic requirement, facilities of education, transportation and other infrastructures are found in fixed amount as required by the people. So, the migration rate is high in this area. People mainly migrate to this area for various facilities due to which they are helped for easiness to settle in this area.

1.3 Objective of the Study

The general aim of this study is to analyze the migration induced social change in Chhorepatan. However its specific objectives are:

- i. to assess the mode of social interaction between migrants and local people in the study area
- ii. to analyze the pattern of cultural exchange between the migrants and the locals of the study area.

1.4 Significant of the Study

The immediate significant of the study is purely academic one of achieving M.A. Degree in Sociology. But this study may have some applied significance too. It is expected that it would be able to find out the relation between local people and migrants and cultural exchange between them. It may be useful to improve socio economic conditions and data records can be used by different organizations to carry out their teacher and development programs. Since, no similar study have been taken place in this study area so far. So this study is excepted to become fruitful and base at local planning process of policy makers, planners, donor agencies and development planners.

1.5 Limitation of the Study

This study is limited to only in Chhorepatan. The records may not be used for the situation of other communities. This present study specifically focused on the social and cultural impact of migration and interaction between local people and migrants.

Sample size 123 from the selected research area so the finding may not be applicable in regional and national level. Despite of my maximum effort there may be small errors and mistakes because minimum data has been taken in suitable time to fulfill the requirements of master degree.

1.6 Organization of the Study

The study has been organized into seven chapter. Chapter one deals with background of the study, statement of the problem, objective of the study, significant of the study, limitation of the study and organization of the study, chapter two deals with background, literature review, structural functionalism, theoretical review, urbanization and review of previous studies. Chapter third deals with research methodology, rational of the selection of the study area,

research design, nature and sources of data, universe and sampling, data collection technique, questionnaire, interview, observation, reliability and validity of the data, operational definition and measurement of selected concepts/variables and data processing and analysis. Chapter four deals with study area and respondents, general introduction of Pokhara, brief introduction of Chhorepatan, selected demographic characteristics of respondents, caste/ethnicity of respondents, distribution of family size of respondents, distribution of family size of respondents, age group of the respondents, distribution of migrations family by sex, educational status of respondents family, religion of the respondents and occupational characteristic of migrations. Chapter five discusses on social interaction between migrants and local people, origin of migrants, reason for choosing Chhorepatan of migrants, first reaction of local residents towards migrants, involvement of in social activities on Chhorepatan, migrants working post in the organization, migrants participation in different activities of tole development, heard your opinion in your organization and change in Chhorepatan after migration, chapter six deals with pattern of cultural exchange between the migrants and the locals. In the chapter seven summary of findings and conclusion have been assembled.

CHAPTER II

LITERATURE REVIEW

2.1 Theoretical Overview

2.1.1 Migration as Social Interaction

People do not live in a place when they feel that they can have happy times after changing their residence from a place where they have been living since long time ago. The place of origin for the migrants and the place where they stop for their living is called the place of destination for the migrants. The term migration is commonly defined as the permanent change of residence by an individual or a group. So migration is an act of the movement of a group of persons or an individual from a well defined area until or political boundary to another during a specific period of time with a view of changing residences. Those people who have their permanent residence in pursuit of how socio-economic activities are called migrants. "In the words context each year people from a part of a continent", migrate to next part of the continent. From Nepal, young people leave their country for a period of time for India. Similarly, people from Vietnam leave their country for Hongkong. (Bhandari 1991)

According to Goffman, society frames interaction but interaction is not dependent on macrostructures furthermore interaction can have a transformative impact on social structures. The key point in Goffman's work is that he rejected the classical sociological opposition between the individual and social structure that still retains credibility in current sociological theory. For Goffman "individual and social structures are not competing entities".

They are "Joint products of an interaction order sui generis" (Rawls, 1987 : 138).

Giddings (2000) social interaction is the process by which we act and react in relation to those around us. While there have always been interactions between people of different nations between people of different nations, globalization has changed both the frequency and the nature of those contacts with globalization a greater proportion of our interactions come to involve directly or indirectly, people from other countries or cultures.

Giddings (2001) claims that migratory movements is not a new phenomenon, it is one that seems to be page 258 accelerating as part of the process of global integration. Worldwide migration patterns can be seen as one reflection of the rapidly changing economic, political and culturalities between countries. It has been estimated that the world's migrant population in 1990 was more than 80 million people, 20 million of whom were refugees. This number appears poised to increase into the early years of the twenty first century, prompting some scholars to label this the age of migration (c.f. castle and Miller 1993).

Todaro (1969) gives the most significant contribution to the large volume of migration literature. According to him migration mechanism can be explained by the differences in "expected" rather than "actual" earnings between two places. He formulates migration model which has four basic features.

- i. Migration is stimulated primarily by rational economic considerations of relative benefits which are mostly financial and also psychological.
- ii. The decision to migrate depends on expected rather than actual wage differentials.
- iii. The probability of obtaining employment rate in the new sector and

- iv. Migration rates in excess of new employment opportunity are not only possible but rational and even likely in the face of wide, new or old expected income differentially.

Boque (1969) follows "Push and Pull" model of Ravenstein. As a person he believes that he cannot satisfy his needs and the atmosphere is undesirable, unpleasant or intolerable, he migrates to other places where he may get relief from these unpleasant situations. To him, push factors are declined in natural resources, lack of employment, natural calamities, the pull factors are: superior opportunities for employment to earn large income to obtain desired specialized education or training, preferable environment and living condition. Migration will cease only when disequilibrium disappears. Migration is favourable to young male and educated ones and affects both size and composition of the population. Moreover the flight of migration is an acute problem specially of developing nations.

2.1.2 Structural Functionalism

Different sociologists have put forward their views and theories regarding sociology. According to Spencer (2001) he compared society to a human body. In the same way each part of the body works in harmony with other parts. If we want to understand the importance of the heart for helping the body function properly, we need to understand how it related to other parts of the body. Similarly, if we analyze the functions of some aspect of society, such as education, we can learn how it impacts the other parts of system. Functionalists emphasize that other the balance are the normal state of society and disruption in one part of the system will certainly disrupt other parts.

Strauss (1963) said the 'Social structure is difficult to define with precision and clarity. It could mean so many people. It touches upon the borderlines of

many disciplines. For example, sociology defines its concept and meaning. Anthropology describes the structure of a given society and its relations between parts: religion provides the interpretation for the background of its values and norms and history traces the origin of the process of its evolution in all its different forms. Thus, the term social structure many one of the most famous theoretical anthropologist of our time refers to a group of problems the scope of which appear so wide and the delimitation so imprecise that is hardly possible for a paper strictly limited in size to meet them fully.

In the same way Durkheim (2001) focused on society rather than an individual. His most outstanding work is the division of labour. He is known as societal functionalist because he believes that all the behaviours and activities are done by an individual directly affect the whole society.

2.1.3 Urbanisation

According to Rao (1990), urbanization became a world phenomenon today. In 1800 (i.e. before the industrial revolution) there were only 2 cities in the world each with a population of 100,000 or over, and all these were in Europe. By 1950 there were 858 such cities in the world (364 of them in the European continent) with a combined population of over 313,000,000. An unprecedented growth has taken place not only in number of great cities but also in their size. England, where the industrial Revolution took place first, became urbanized at a relatively faster rate. England, America, Germany and Israel are the most urbanized countries of the world where more than 75% of the people live in towns and cities.

Ritzer (2000) described urbanization as a result of the industrial revolution where large number of people in the nineteenth and twentieth centuries were uprooted from their rural homes and moved to urban settings. This massive

migration was caused in large part, by the jobs created by the industrial system in the urban areas. But it presented many difficulties for those people who had to adjust to urban life. In addition, the expansion of the cities produced a seemingly endless list of urban problems overcrowding, noise pollution, traffic and so forth. The nature of urban life and its problems attracted the attention of many early sociologists, especially Max Weber and George Simmel. In fact the first major school of American sociology the Chicago school was in large part defined by its concern for the city and its interest in using Chicago as a laboratory in which to study urbanization and its problems.

Srivastava (2002) social life in the country side moves and develops in a rural setting just as social life in the urban area moves and develops in an urban setting. Their respective settings considerably determine rural and urban social life.

A correct comprehension of the specific characteristics of the rural framework is, therefore indispensable for a group grasp of the distinct features of rural social life. Such study constitutes the first task of the rural sociologist and can be accomplished by studying in contrast the distinctive features of rural urban settings. A brief outline of the principal points of contrast between the rural and urban setting will show how the different structures and life-processes of rural and urban societies are to a great extent the consequence of the difference between those different settings.

Outstanding sociologists have said down a number of significant criteria for distinguishing the rural social composition of population, the degree of the complexity of social structure and social life, the intensity and variety of

social contact and others. They have finally attempted to trace the sharp differences and contrasts between the two types of social phenomena rural and urban, largely to the based differences between the rural and urban settings.

The following are the most important criteria of distinguishing the rural. Social world from the urban social world.

1. Occupational differences
2. Environmental differences
3. Differences in the size of the communities

Kharel (2005) analyze both the pros and cons of labour migration. According to her, temporary movement of workers lessens the burden on the over crowded domestic market. But remittances are blamed for encouraging social and economic idleness. For example a family sustained by remittance may leave its land completely barren. Partly because of the 'houveau rich' syndrome or partly due to lack of able bodied men to mind the fields. On the one hand, during their stay abroad, they send a steady supply of remittances to their families or make direct investment in the home country, when they return they repatriate knowledge and skills as well, which can be advantages, depending on how the government capitalize on their strength.

Adhikari (1996) has noted the lack of research into how labour migration and remittances affect local village and household economy and society. According to him most research studies conducted in Nepal have paid little assention to the growing role of affe economy. Although a few studies give some account of aff farm employment, their main concern has been with the

relatives size of the income generated rather than with its role in the livelihood strategies of different village groups.

Pyakurel (1978) Pointed out that 76% of total migrants mainly belonging to Sarkis, Giris and Gurung families are able bodied males in Satdanda village Panchayat. And most of the migrants are literate and above 88% of the activities males are employed fully in their area of destination. Population pressure, low productivity and lack of resources push the rural people from their native village. Whereas expanding of the Terai and bright light of city are the main attraction of internal migration. Availability of long term employment, high wages and to be the Dure is the attractive factors for external migration.

Shakya (2009) Internal migration is not a new Phenomenon in Nepal. It has long been a used as a strategy to making a living by the Nepalese population and especially rural to urban migration has played a part in the eastern Hill region of Nepal. But the increased demand for income generating activities and interest in education, has also initiated rural urban migration (Subedi 2006). Urban centers across the border in India have been popular destinations but increasing numbers are moving to Kathmandu, and the urbanization degree is escalating dramatically. Especially the increased quality of higher education in the capital area leads to increased migration and the number of internal educational migrants are similarly on the rise.

2.2 Review of Previous studies

Migration is the movement of people either across an international border or within a state. It is population movement encompassing any kind of movement of people whatever its length, composition and causes. It includes

migration of refugees, displaced persons, uprooted people and economic migrants.

Myron (1971) made the first study on internal migration and implication of these component in social and political affairs of Nepal. He concluded basic reason for migration high hill destiny per unit land employment opportunities outside the hills and malaria eradication in the terai region. The report concluded that pursue a policy of developing first those regions with the great economic disparities and provoke political conflicts to do otherwise may be to show the pace of national economic growth.

Kunwar (1993) analyzed causes and consequences of internal migration phenomenon through the multivariate analysis as well as path model. He concluded that low productivity and insufficient land are the main causes of leaving origin and availability of physical facilities, extension or business opportunities reduced the causes of leaving origin, but moving of relatives and friends, education increased the causes of leaving origin. He also concluded that age factor also played significant role in the process of migration.

Acharya (2000) concluded that immigration is the general phenomenon because the shape increases in population of the destination in comparison to the origin. Immigration is also a problem for economic development because it creates a population problem in the receiving regions. More even, it shortens the size of land by reducing production. He focused that transportation, health, education and communication, better employment, opportunity and malaria eradication are most favourable for migrations to Byas municipality. The problem of increasing population is a great problem

of Nepal because of the growth rate of Nepal which is 2.1 percent annum. Similarly in Byas migrants have overall family size which is unfavourable to raise the standards of living of the households.

Gurung (2001) explain the out flow of population its impact on socio-cultural environment of Karapu VDC in Lamjung district, owing to its scope to poography, has given rise to uneven distribution of rural settlements. The villages of the study area generally consists of clusters of houses with foot paths and surrounded by cultivated fields all around and the general patterns of land use includes multi cropped at nearby settlement around inhabit are side followed by single cropped zone of seasonal irrigated area in the periphery the field sizes shown rectangular terrace pattern and are of small size. Major portion of the village land is owned by Gurung community and scheduled castes people are mostly landless and lead a traditional works. Moreover, there is a scarcity of food grain in area of which food sufficiency up to a year and food surplus households are recorded 17.04% and 20.14% respectively. It indicated the shortage of basic necessity such as food in village from their own agriculture educational structures of the region also has seem discouraged to remain their because there is no higher level of education and modern based education system in the study area for which, people have to migrate other destinations in search of better facilities to sustain and compete the present situation of the society.

Kattel (2006) also made a studying valam VDC in Kaski district. She concluded the significance of labour migration to the Nepalese economy has been growing over time. Although the objective of labour migration is mainly economic it has direct and indirect impacts on social aspect as well. Labour migration has become an important aspect of development because it has

helped in enhancing various prerequisites of development such as raising people's standard of living. But in spite of that, the government has not paid due attention to it. This study is an attempt to describe and analyse the pattern involved and its impact on the concerned families as well as the society as a whole.

Timilsina (2007) concluded the internal migration history of Nepal, rural urban migration has been increasing after mid 1990s. It is because of the extreme Maoists and Government conflict in the rural areas of Nepal after the Maoist insurgency in the country. In addition to this, there are huge disparities between rural and urban areas of Nepal in terms of socio-economic and infrastructure development. Kathmandu is by far a favourable destination to all. This ultimately creates high population concentration in the valley and gives pressure in the informal activities; street vending is one of the main activities among them.

GC (2008) Rural and urban areas are interdependent to each other. One needs mutual and integrated support for better standards this kind of symbiotic relationship promotes rural production in one hand and on the other, it gradually uplifts the living standards of the rural people. Actually, it is not only the matter of give and take with rural area, it enhances in the quality of the services that rural people need and get from the town. It is before, essential for the sustainable development of both rural and urban area. In fact, the pace (speed) of the development cannot take off without mutual connection of village and town. The development of market towns in the village is a great opportunity for rural people where they can sell handicrafts, agricultural production, wild production etc. In the meantime, facilities extended from the market center are not which significant without its hinterlands. Farmers of

small land holders who reside in rural area get direct advantage of researchable. They produce primary products and sale them in the local market as well as in the core market. Similarly the people of urban area and its hinter land also get advantage that consume rural products and satisfy their demands co-operatives which have been establishing to faster the relationship between rural and urban area also extend their networking different sector of the need and interest of the people.

Poudel (2012) made the first study on in Immigration situation in Rajahar village development committee, Nawalparasi. He concluded basic reason of migration, to asses the nature and volumes of in migration to identity the pull and push factors of in migration. According to him the trend of migration is increasing everyday which has created a serious problem in using resources and its implementation on development and plants and politics.

2. Research Gap

As reviewed above, migration that focus not only on urbanization in Nepal but also on the urbanization in the world, and their number is increasing. Total two migrations is reviewed in the contents of migration, one is internal migration and other is external migration. Urbanization has already proved to be fruitful subject for migration. There appears an absence of qualitative anthropological orientation while looking at urbanization in Nepali context. Thus this study has been made an attempt to fulfill this lacuna.

CHAPTER III

RESEARCH METHODS

3.1 Rational of the Selection of the Study area

Chhorepatan is in the important part of Kaski district of Gandaki zone. This area occupies an important place in Kaski district. This study area is also known as the junction of the Siddhartha highway. After the construction of Siddhartha Highway in this area became the most important part of district and started to develop and then different people from different districts have migrated in the study area. But there has been less attempt to make any research. Nowadays the study area has been facing different problems due to over population.

Thus the case of Chhorepatan has been selected on the basis of following considerations.

- It is impossible to select a large area for primary data collection because it takes much time and money.
- Due to migration Chhorepatan has been adversely affected in almost every sector of economic, social and political sectors.
- The study area has population of mixed caste ethnic groups.
- There was no past study carried out on migration in this area.

3.2 Research design

Descriptive and exploratory research design were employed in this study. The study attempt to describe and document the socio-economic conditions of migrants in Chhorepatan sub metropolitan city of Kaski district. It is

expected that this research design was able to describe the Characteristics of the research objectives.

3.3 Nature and sources of data

In the study the data collected here are both qualitative and quantitative in nature, for this primary and secondary data was collected primary data were collected from field work using interview with respondent by personal contact. The secondary data were collected from relevant literature. Journals and reports.

3.4 Universe and Sampling

This study has been conducted in Chhorepatan submetropolitan city of Kaski district. It is known that study area consists of 4 Tole Bikash Sanstha and most of the migrants are concentrated in 4 tole Bikash Sanstha respectively. So these four Tole Bikas Sanstha are concentrated for study.

Before sampling all survey was done to enumerate the total number of migrant household in Chhorepatan. From this survey it was found that there were 1170 migrant households. Out of these households 123 households were chosen as samples. At first households were divided according to toles and act of total households in each tole 10.51% households were picked out by purposive sampling. Not all people were willing to respond. Initially the researcher attempted used stratified random sampling however. In the household selected offer sampling. It was difficult to meet respondents as they were out of households or unwilling to respond. Due to this reason purposive sampling was used.

The are 123 households are migrated in the study are. geographically the study area is divided into 4 Tole Bikash sanstha which are:

1. Sitalchautari Tole Bikash Sanstha
2. Davis fall Tole Bikash Sanstha
3. Simaltuda Tole Bikash Sanstha
4. Belghari Tole Bikash Sanstha

Among them 40 migrants households are from Sitalchautari tole bikas. 35 migrants household are from davis fall tole bikas, 25 migrans households are from Belghari tole bikas and 23 migrants households are from Simaltuda tole bikas Sanstha.

3.5 Data collection Technique

Different techniques were applied to collect data have been discussed below:

3.5.1 Questionnaire

The structured questionnaire was designed to get information on sex, caste/ethnic, place of origin, occupation, years of migration, reason for migration, number of migrants by age and sex, religion, family size and educational status etc. The information about changes that have taken place in Chhorepatan mainly due to in-migration have been collected by using the questionnaire prepared. Both closed and open ended questions were included in the questionnaire.

3.5.2 Interview

Key informant Interview technique was used to collect qualitative information. Researcher conducted interviews by visiting door to door. Altogether of 5 respondent individual were interviewed. Generally the key informants were native people. People those who had better knowledge of the

problems cause and other important information about migrations the member or head the of migrants member or head of the migrants were selected for the interview. Interview was taken with successive member of the family if the senior member was found to be unavailable.

3.5.3 Observation

This study was conducted by observing the physical condition and living standard of migrants mode of social interaction between migrants and local people, cultural exchange between the migrants and the locals. In Chhorepatan, observation was used to find out the phenomena which could not be investigated through the previous two methods.

3.6 Reliability and Validity of the Data

For the reliability and validity of the study, the researcher visited the respondent individually. To fill the schedules as well as informal interviews were also conducted, where cross check method also used to maintain reliability of the data when necessary. The research instruments were prepared in Nepali and ban slated into English when necessary. The respondents were familiar with the nature and objectives of the study. To check instruments necessary modifications and alternations were done in the tools in the field. So the collected data were reliable enough. The content validity method also applied to maintain the validity of data. Hence, the tools were reliable and the interpretation be valid.

3.7 Operational Definition and Measurement of Selected Concepts/Variables

Migration: Migration means physical movement of people from one place to another for the betterment of life.

Migrants: The people who have been migrated from other place or

Chhorepatan. Local residents: The people who have been living in Chhorepatan for the last 3 generation is termed as local residents.

3.8 Data Processing and Analysis

All the data are presented and analyzed to fulfill the objective. In this research some descriptive statistical tools such as frequency and percentage are used to analyze data. The data are also presented with the help of suitable tables and figures.

CHAPTER IV

STUDY AREA AND THE RESPONDENTS

4.1 Study Area

4.1.1 General Introduction of Pokhara

Pokhara is located at western region. It is highly urbanized city. Almost all the facilities or all the basic need that human civilization wanted are fulfilled in this city. This city is mainly famous in terms of tourism. People in this city are highly literate and civilized, people here help each other in requirement, follow and respect each others culture and tradition. The thought at this city mainly emphasize on the brotherhood and sisterhood between the migrants and local people. Due to highly arrival of tourist, the people in this city are highly modernized as a respect to other city.

The study area, Chhorepatan is developing into sub-metropolitan toward the urbanization. the sub-metropolitan comes on the Kaski district of Gandaki zone in the western region of our country Nepal. It lies almost at the central part of the district and situated at bank of Fewa lake.

The study area Chhorepatan occupies an important place among the several sub metro Politian in Kaski district. The study area is one of the central part of Siddhartha highway. Geographically this area represent inner hilly area. The study area is also known as junction of Siddhartha highway. After the construction of Siddhartha highway this area was started to develop but this

was totally neglected before the construction of Siddhartha highway. Almost all the tole in this area are develop.

Monsson is the dominant climate. Summer and winter are two distinct season. Due to the dominant and due to the presence of Machhapuchhre Himalaya. This area is almost cool or moderate.

4.1.2 Brief Introduction to Chhorepatan

Chhorepatan lies in Ward No. 17 of Pokhara. Administratively this ward no 17 is largest ward in pokhara. The total population of this ward is according to ward office-17, Chhorepatan are divided into 4 tole bikas sanstha where there is presence of 1358 households. Among the 1358 households,188 household are belonging to old citizens and 1170 are migrant households. From this data we came to know that almost all population belonging to this area are populated by the migrants.

4.2 Selected Demographic Characteristics of Respondents

4.2.1 Caste/Ethnicity of Respondents

In any society caste/ethnicity plays an important social role. It reflects the social characteristic of the society. In Chhorepatan there are a many different caste groups namely Brahmin Chhetri, Gurung, Magar, Gharti and others. Among them Brahmin, Chhetri and Gurung is the largest cast group.

Table 4.1

Distribution of the Respondents by caste/Ethnicity

S.N.	Caste/Ethnicity	Number	Percent
1	Brahmin	31	25.2
2	Chhetri	30	24.4
3	Gurung	29	23.6
4	Magar	10	8.1
5	Gharti	6	4.9
6	Dalit	12	9.8
7	Others	5	4.0
	Total	123	100.0

Source : Field Survey, 2015

Figure 4.1

Distribution of the Respondents by caste/Ethnicity

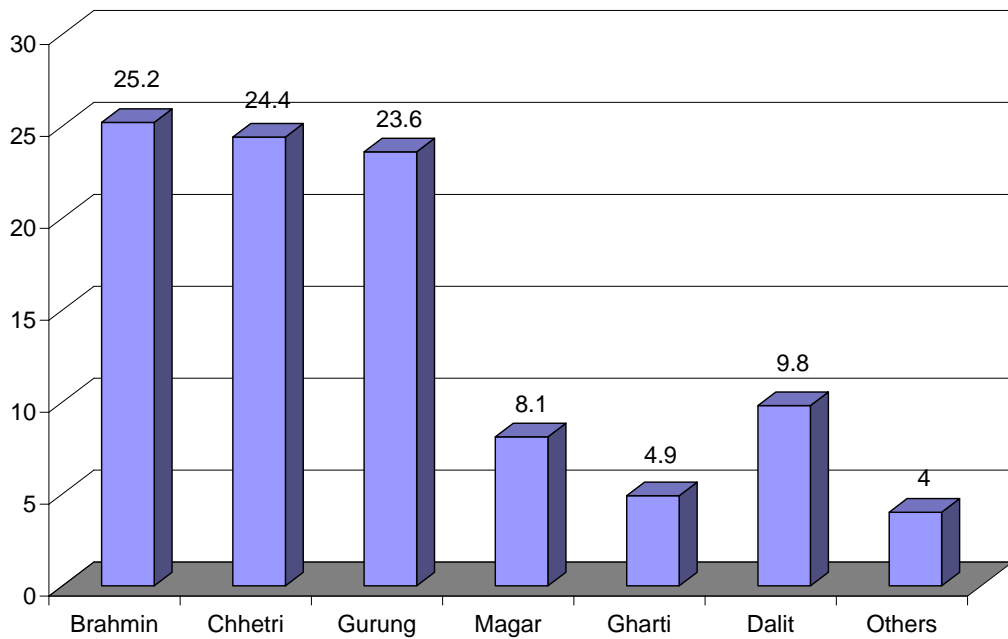

The above table reveals that the people living in that area are Brahmins and followed by Chhetri, Gurung and so on. Brahmins holds the highest

percentage of 25.2 and 50 on. Brahmins holds the highest percentage of 25.2 where as others holds the least percentage i.e.4.0.

4.2.2 Distribution of Family size of Respondents

It is defined as a fundamental social group in society typically consisting of one or two parents and their children in order words family can also be defined as two or more people who share goals and values have long term commitments to one another and resident usually in some dwelling. The movement of people is not only determined by individual decisions, but also it is influenced by socio-economic.

Table 4.2
Distribution of the Respondents by family

S.N.	Family size	Number	Percent
1	upto 4	55	44.7
2	5 -7	62	50.4
3	8 and more	6	4.9
	Total	123	100.0

Source : Field Survey, 2015

Figure 4.2
Distribution of the Respondents by family

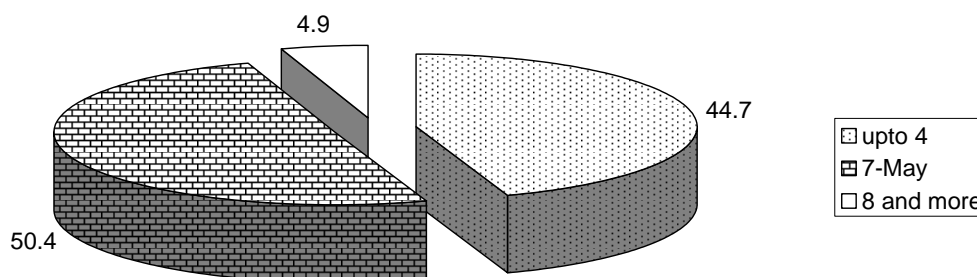

From the above table 44.7% of respondents are the family size upto 4 and 50.4% households have the family size from 5 to 7 and 4.9% have the family size 8 and more. From the table we conclude that the highest percentage of family size in Chhorepatan holds by 5-7 family size which is 50.7 and family size.

4.2.3 Age group of the respondents

Age also plays an important role for the potential migrants to move for one place to another in search of betterment of their life. The migrants migrated in the study area in different age. Age composition not only helps to discover the age of the people but also the number of people who are economically active or are depends.

Table 4.3
Distribution of the Respondents by age

S.N.	Age Group	Number	Percent
1	16-25	14	11.4
2	26-35	38	30.9
3	36-45	26	21.1
4	46-55	19	15.4
5	56-65	12	9.8
6	66 or above	9	7.3
7	unresponded	5	4.1
	Total	123	100.0

Source : Field Survey, 2015

The above 11.4% were in the age group 16-25, 30.90 in the age group 26.35. 21.1% in the age group 36-45, 15.4% in the age group 46-55. 9.8 percentage in the age group 56-65 and 7.3% in the age group 66 or above 4.1% did not responded.

4.2.4 Distribution of migrants family by sex

It is defined as the sum of the structural and functional difference by which the male and female are distinguished or the phenomena or behavior dependent on these difference or It is also defined as male or female division of a species, Especially as differentiated with reference to the reproductive function.

Table 4.4
Distribution of migrants family by sex

S.N.	Sex	Number	Percent
1	Male	77	62.6
2	Female	46	37.4
	Total	123	100.0

Source : Field Survey, 2015

Figure 4.3
Distribution of migrants family by sex

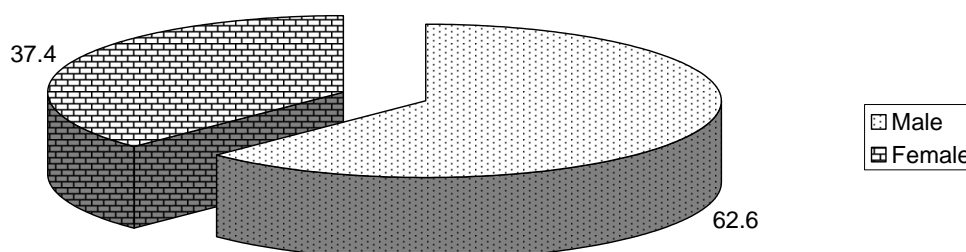

According to the sex migrants are mainly classified into sex male and female where around 62.6% are male and 37.4% belonging to female from this data we came to know that the population of this area is highly populated by the male.

4.2.5 Educational Status of Respondents Family

Educational is one of the most important factors of socio-economic development. In the study area, the migrant having different educational status found. But majority of them were literate.

Table 4.5

Distribution of the Respondents Family by Level of Education

S.N.	Educational Qualification	Number	Percent
1	Illiterate	1	0.8
2	Literate	41	33.3
3	SLC	32	26.0
4	+2	27	22.0
5	BA and above	16	13.0
6	Unresponded	6	4.9
	Total	123	100.0

Source : Field Survey, 2015

From the above table,33.3% of people are literate,26% had passed SLC,22% have secured pass mark in +2 level while 0.8% of people are illiterate. From this data we came to understand that the migrants level in this area are highly literate.

4.2.6 Religion of the Respondents

It is defined as the set of belief concerning the cause, nature and purpose of the universe, especially when considered as the creation of a superhuman agencies, using involving ritual observances and often containing a moral code of governing the conduct of human affairs.

Table 4.6

Distribution of Respondents by religion

S.N.	Religion	Number	Percent
1	Hindu	95	77.2
2	Buddhist	22	17.9
3	Hindu Buddhist	3	2.4
4	Others	3	2.4
	Total	123	100.0

Source : Field Survey, 2015

Figure 4.4

Migrants Engaged organization and activities in Chhorepatan

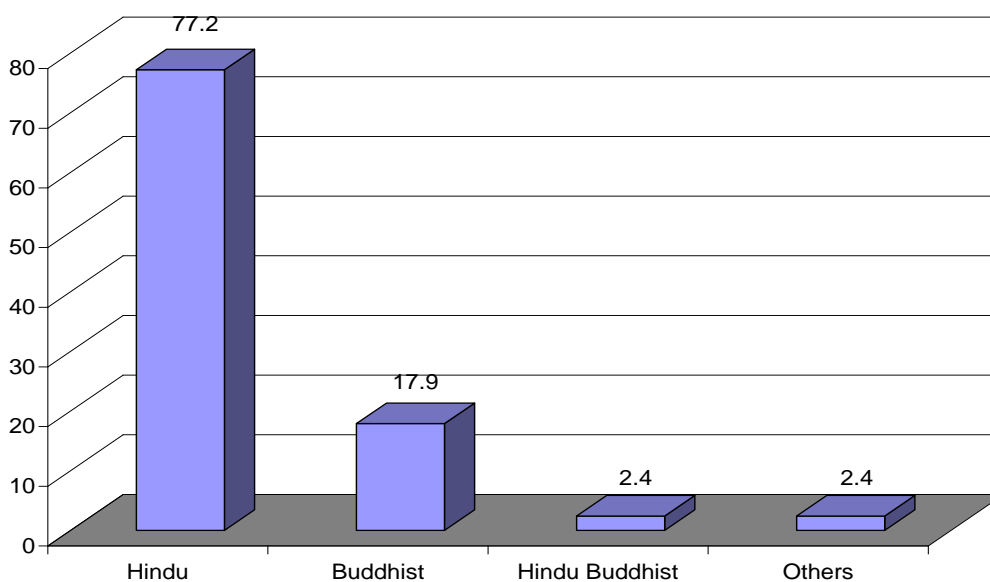

Among the total migrants Hindu religion have highest in number with 77.2%. 17.6% of migrants are Buddhist of wants to follow Buddhist. The migrants in this area also follow both Hindu Buddhist which is 2.4% in number. so this area is highly populated by Hindu religion

4.2.7 Occupational characteristic of Migrants

This area is highly populated by the migrants where their main occupation is business/trade and services. Further migrants work as a laborer as a farmer for their livelihood.

Table 4.7
Main Occupational Characteristic of Migrants

S.N.	Occupation	Number	Percent
1	Service	33	26.8
2	Trade/Business	34	27.6
3	Wage/Labouring	2	1.6
4	Farming	8	6.5
5	Others	31	25.2
6	No occupation	15	12.2
	Total	123	100.0

Source : Field Survey, 2015

From the above data 26.8% of the migrants work as a servicer in an organization. The majority people in this area job as a trade/business which is almost 27.6%. The rest people work as a farmer (6.5%) and a laborer (1.6%). Some of them are those migrants who don't do their occupational work where their population rate is 12.2%.

CHAPTER V
SOCIAL INTERACTION BETWEEN MIGRANTS AND LOCAL
PEOPLE

5.1 Origin of Migrants

The migrants in this area mainly originated from neighboring district. The majority number of migrants are migrated from Syangja district. Some of the migrants are also evolved from Parbat and Kaski district.

Table 5.1
Distribution of origin of migrants

S.N.	District of Origin	Number	Percent
1	Kaski	33	26.8
2	Parbat	20	16.3
3	Syangja	59	48.0
4	Others	11	8.9
	Total	123	100.0

Source : Field Survey, 2015

Figure 5.1
Distribution of origin of migrants

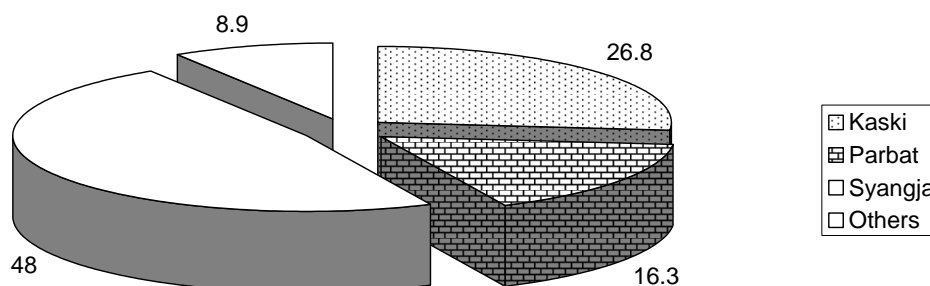

From the given reference data majority people were migrated from Syangja district whose population is 48%.The people from Kaski and Parbat are also migrated to this area whose population rate is 26.8% and 16.3% respectively.

5.2 Reason for Choosing Chhorepatan of Migrants

Reason for choosing Chhorepatan of migrants there are many reason for the selection of Chhorepatan by the migrants. The main reason is facilities like education health, job opportunities, transportation and others. Also due to the relatives people migrate to Chhorepatan.

Table 5.2
Distribution of origin of migrants

S.N.	Reasons	Number	Percent
1	Because of relatives	41	33.3
2	Because of facilities	39	31.7
3	Easy to settle	43	35.0
	Total	123	100.0

Source : Field Survey, 2015

Figure 5.2
Distribution of origin of migrants

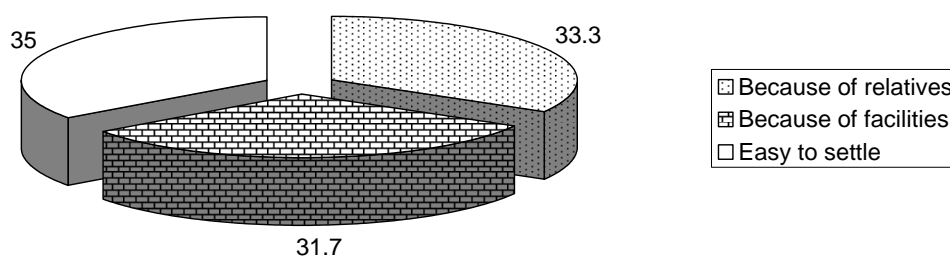

From the table it shows 33.3% respondent migrated because of the relatives and 31.7% respondent migrated because of facilities where as 35.0% respondent migrated because they found it easy to settle. From the data it is clear that people migrated to this area due to their relatives and facilities.

5.3 First Reaction of local resident towards migrants

In my survey the first reaction of local resident towards migrants was in the form of brotherhood and also in the form of help due to which migrants became easily acceptable in Chhorepatan.

Table 5.3
First Reaction of local resident towards you

S.N.	Reaction	Number	Percent
1	Brotherhood	19	15.4
2	Helpful	96	78.0
3	No reaction	5	4.1
4	Can't say	3	2.4
	Total	123	100.0

Source : Field Survey, 2015

Figure 5.3
First Reaction of local resident towards you

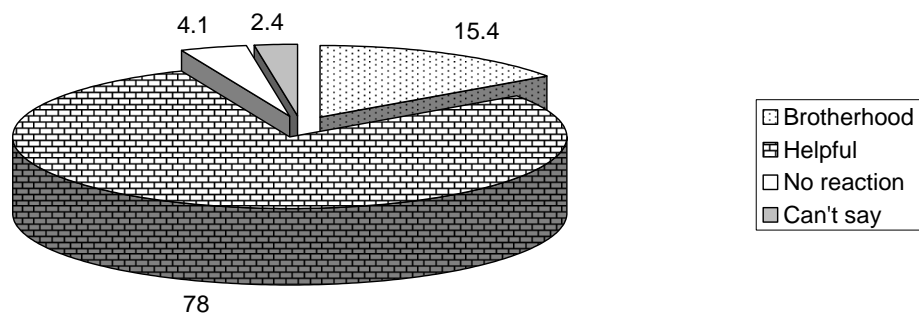

During my survey most of them respondents helpful and many of them showed their brother hood and few did not reacted.

5.4 Involvement of in Social Activiites on Chhorepatan

During my survey it was clear that the first reaction of local resident towards migrants was in the form of helpfulness which was 78%. The other reaction that migrants got from local resident was in the form of brother hood which was 15.4%.

Table 5.4

Migrants Engaged organization and activities in Chhorepatan

S.N.	Attainted organization	Number	Percent
1	Tole Bikash Samiti	19	15.4
2	School Management committee	96	78.0
3	Others	5	4.1
4	Not engaged	3	2.4
	Total	123	100.0

Source : Field Survey, 2015

Figure 5.4

Distribution of Respondents by religion

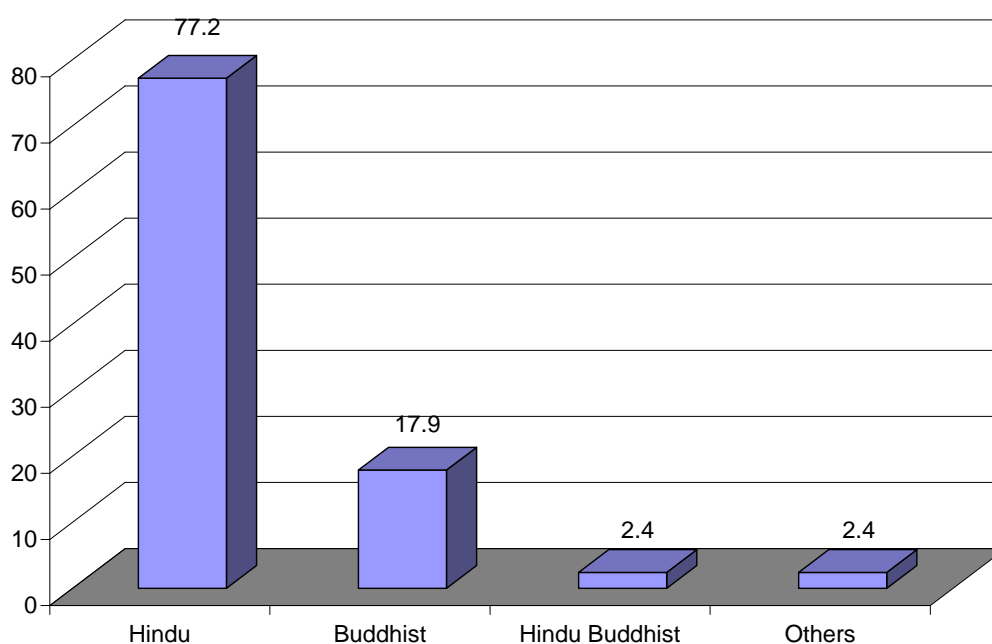

From my survey the migrants in this area highly participated themselves in various attended organization. The majority people attended themselves in school development committee which was 78%, the population rate 15.4% also participated in various tole bikas samiti.

5.5 Migrants working post in the organization

In my fieldwork the rate of migrants is highly based as membership post in various organization. Some of the migrants post themselves as chairman/co-ordinator and vice chairman/vice coordinator in the organization. In any organization people can assume a number of posts in executive as well as other committees. The working post of the respondents in such committees is given below:

Table 5.5
Migrants Working Post in the Organization (N=18)

S.N.	Post	Number	Percent
1	Chairman/Co-oridnator	9	7.31
2	Vice Chairman/Vice coordinator	11	8.94
3	Member	79	64.22
4	Others	24	19.51
	Total	123	100.0

Source : Field Survey, 2015

Among the total engaged respondents the majority of people whose population rate as 47% involved themselves as membership post in various organization. The other migrants evolved themselves as chair/co-orrdinator

and vice chairman/vice co-ordinator in various organization whose population rate is 10.8% and 13.3% respectively.

5.6 Migrants participation in different activities of tole development

Migrant participated or put their hands and effort in various activities of tole development. Some of the migrants in low capacity participated in some of the activities of tole development.

Table 5.6

Migrants working post in the organization

S.N.	Response	Number	Percent
1	Yes, in most of them	112	91.1
2	No	8	6.5
3	In some of them	3	2.4
	Total	123	100.0

Source : Field Survey, 2015

Figure 5.5

Migrants working post in the organization

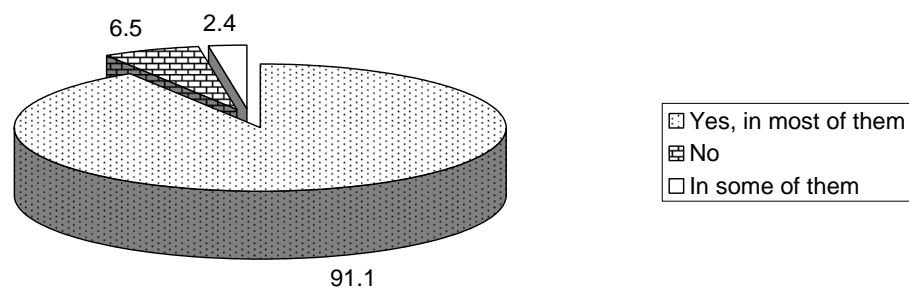

From my survey the majority of people are helpful in their behavior and things. so they participated in various activities in tole development. The participated population rate where 91.1% while 2.4% of people participated in some activities. 6.5% are those migrants who neglected in the participation.

5.7 Heard your opinion in your organization

From my survey the majority of the respondent find themselves heard their little opinion by the various organization while some of the migrants was those whose all opinion was heard by the organization.

Table 5.7
Heard your opinion in your organization

S.N.	Response	Number	Percent
1	Totally	35	28.5
2	Literate	78	63.4
3	Not any	6	4.9
4	Not answered	4	3.3
	Total	123	100.0

Source : Field Survey, 2015

Figure 5.6
Heard your opinion in your organization

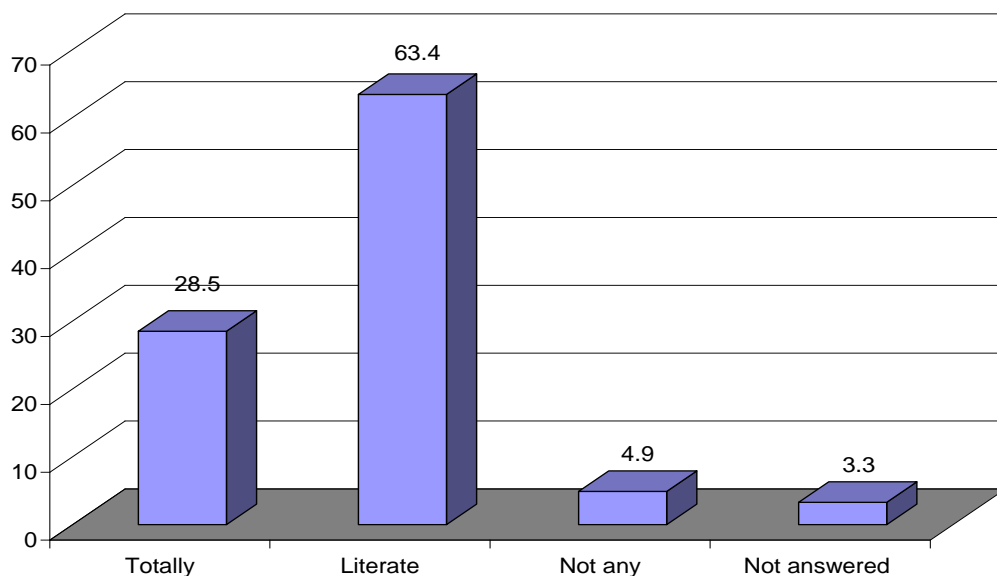

From the above given table it was clear that high rate of opinion was heard by the various organization whose percent rate was 28.5%. The majority opinion was respond was 28.5%. The majority opinion was respond in little by the organization whose rate is 63.4%.

5.8 Change in Chhorepatan after migration

Due to the arrival of the various migrants drastic change has been occur in every field in this area. The majority changes that took place in this area is development of infrastructures and other further changes were population growth and effect on drinking water.

Table 5.8
Change in Chhorepatan after migration

S.N.	Changes	Number	Percent
1	Population	22	17.9
2	Road/Transport	36	29.3
3	Housing	28	22.8
4	Education, Health and drinking water	20	16.3
5	Others	14	11.4
6	Hot much	3	2.4
	Total	123	100.0

Source : Field Survey, 2015

The table shows that 17.9% respondent found change in population similarly 29.3% respondents found changed in roads/transport, 228 respondents found change in housing, 16.3% respondents found change in education, health and drinking water and 11.4% change in others where as 2.4% did not found any change.

CHAPTER VI
PATTERN OF CULTURAL EXCHANGE BETWEEN THE
MIGRANTS AND THE LOCALS

6.1 Differences of the respondents from local people

The majority migrated people do not show any difference towards their living habit as compare to the local resident. But some of the migrants thought little changes in their livelihood as compared to the local resident.

Table 6.1
Difference from local people

S.N.	Response	Number	Percent
1	Non any	61	49.6
2	Little	44	35.8
3	A number of differences	15	12.2
4	Not response	3	2.4
	Total	123	100.0

Source : Field Survey, 2015

Figure 6.1

Difference from local people

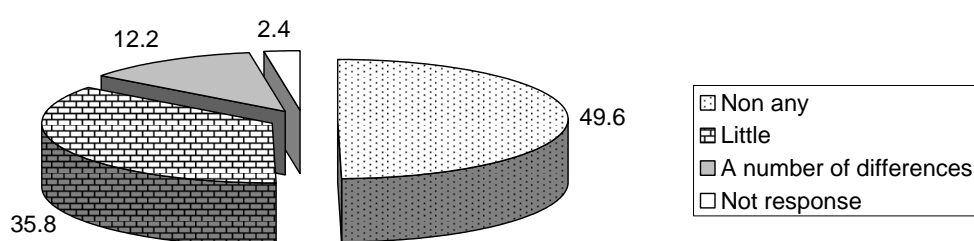

From the given survey data around 49.6% migrated people thinks no changes in their livelihood as compare to local resident. 35.8% people thinks there is little change in living style as compare to local resident.

6.2 Migrants way of performing birth, death and marriage rituals

In this society majority of people take each others help in performing birth death and marriage rituals while minority people celebrate birth death rituals while minority people celebrate birth, death and marriage own way.

Table 6.2

Migrants way of performing birth, death and marriage rituals

S.N.	Response	Number	Percent
1	By taking others help	115	93.5
2	In own way	6	4.9
3	Not responded	2	1.6
	Total	123	100.0

Source : Field Survey, 2015

Figure 6.2

Migrants way of performing birth, death and marriage rituals

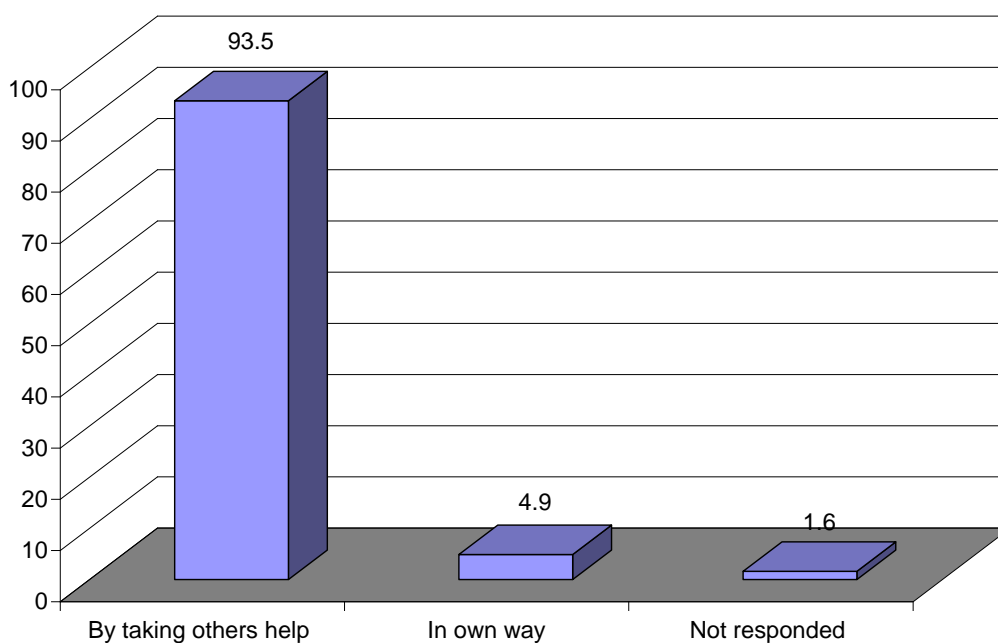

From the above table we found most of the migrants i.e. 93.5% perform their rituals by taking others help and the remaining on their own way.

6.3 Migrants get invitation from locals in their rituals

The study area has high number of literate people due to which thinks of helping and needing each other was followed by them. Similarly, due to this thought migrants are invited in various rituals by the local resident.

Table 6.3

Migrants get invitation from locals in their rituals

S.N.	Response	Number	Percent
1	Yes	121	98.4
2	No	2	1.6
	Total	123	100.0

Source : Field Survey, 2015

Figure 6.3

Migrants get invitation from locals in their rituals

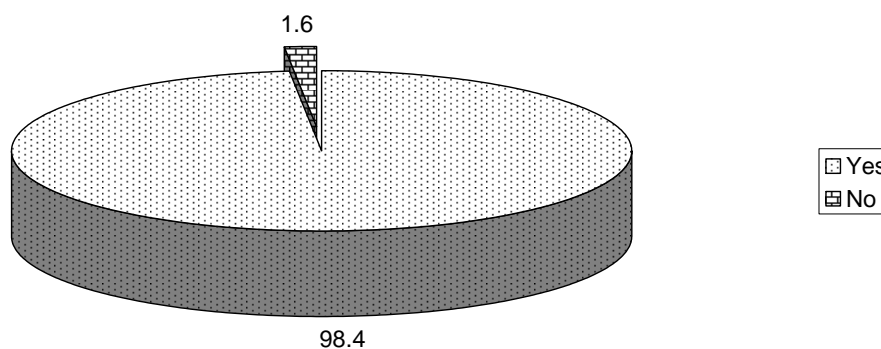

From the above table it is clear that almost all people around 98.4% people invites or provide invitation notice to the migrants in their different rituals or ceremony. Some of the people are so short-minded people that they do not invite the neighbors migrants in their rituals whose percent rate is 1.6%.

6.4 Type of participation played in locals Rituals

Due to the invitation given by the local resident to the migrants, migrants shows their full participation in rituals. Some of the people in majority show active participation in helping as in the rituals while some of them preferred as a guest in the rituals.

Table 6.4

Type of participation by respondents in locals Rituals

S.N.	Response	Number	Percent
1	Active and helpful	111	90.2
2	Present only as a guest	10	8.1
3	Others	2	1.6
	Total	123	100.0

Source : Field Survey, 2015

Figure 6.4

Type of participation by respondents in locals Rituals

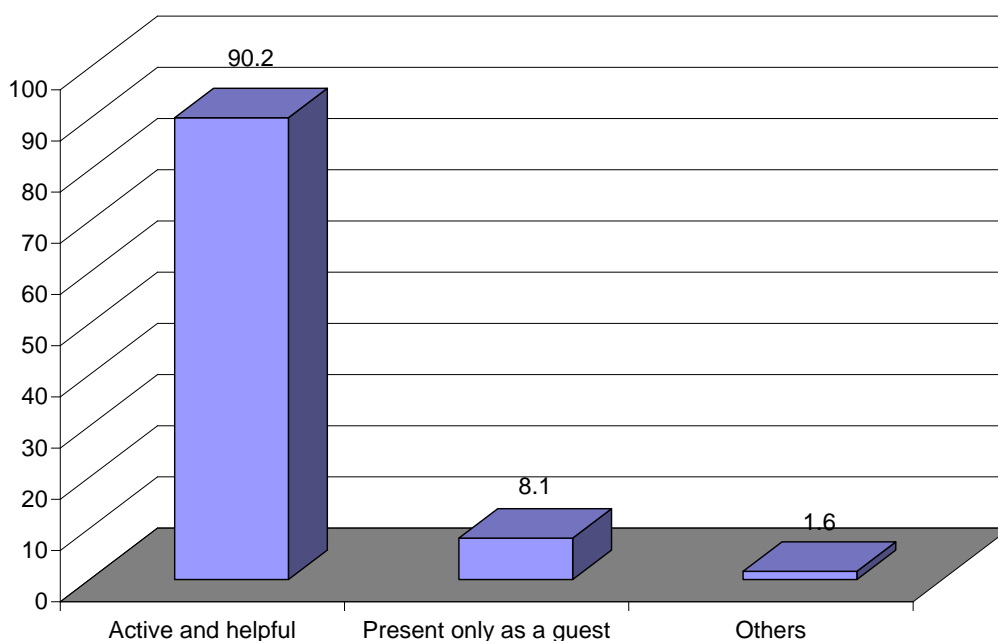

From the above given table it is clear that most of the migration rate put their active role in helping the people as best as they can in the ritual. The

migration rate of this people is almost 90.2%. Some of the migrants are those people who participate as only a guest in the rituals whose percentage rate is 8.1%.

6.5 Type of participation by locals in their rituals

Not only the migrants but the local people show their full participation hanging around by helping and by active participation in the rituals of the migrated people. Almost 0% of people do not neglect on the participation of the rituals.

Table 6.5

Type of participation by locals in respondents rituals

S.N.	Response	Number	Percent
1	Help actively	98	79.7
2	Little help	22	17.9
3	Not much	1	0.8
4.	Not responded	2	1.6
	Total	123	100.0

Source : Field Survey, 2015

From the above given survey table 79.7% of people have active help in the ceremony of the migrated people while 17.9% of people played little rate in helping the migrated people in their rituals. Almost non local resident do not play any role in the participation of their rituals.

6.6 Type of participation of people of the place of origin

Due to the high literate rate of both migration and local people, the participation of helping each other is more seen in the area. Almost all people play active role in helping in various works that is carried out in this area.

Table 6.6

Type of participation by locals in their rituals

S.N.	Response	Number	Percent
1	Help actively	112	91.1
2	Little help	9	7.3
3	Not responded	2	1.6
	Total	123	100.0

Source : Field Survey, 2015

Figure 6.5

Type of participation by locals in their rituals

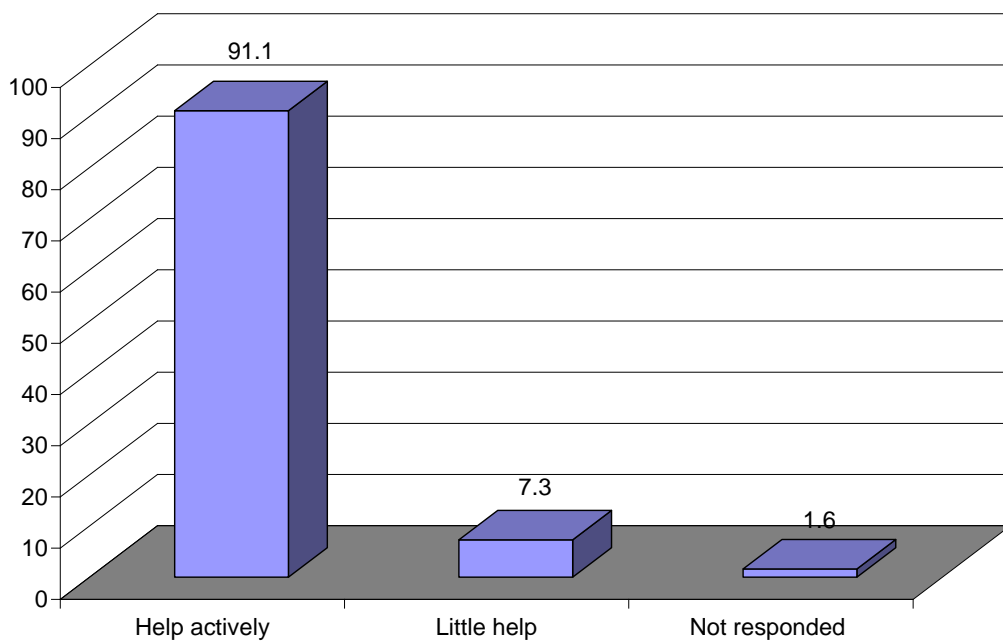

From data above data almost 91.1% respondents found people helping actively in various work or in the various field. But some of the people around 7.3% choose some field in helping the people. Almost 1.6% of people do not take any emphasis on helping the people

6.7 Feeling in the activities of death ceremony in this place

Death is certain or certainty thing that is happened in all the people's life. It does not give any single or chance that it is happening. Naturally without any thought it occurred. So after the death of people, death ceremony occurred when due to participation of almost all people it is easily celebrated.

Table 6.7

Feeling in the activities of death ceremony in this place

S.N.	Response	Number	Percent
1	Easier than before	91	74.0
2	More difficult than before	25	20.3
3	Not responded	7	5.7
	Total	123	100.0

Source : Field Survey, 2015

Figure 6.6

Feeling in the activities of death ceremony in this place

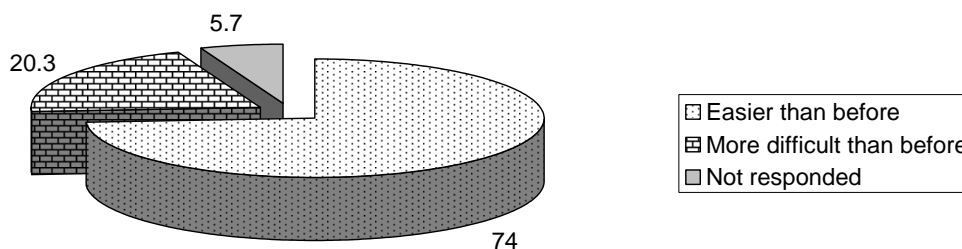

From the above given table it is clear that as compared to before 74% people think death a ceremony is easy to celebrate with any difficulties this happened due to strong or deep participation by the local people in the

migrated family. Some of the people thinks (around 20.3%) it is more difficult to celebrate this ceremony as compared to before.

6.8 State of reciprocal exchange

From my survey reciprocal exchange also take place in this area. Almost all people think that reciprocal exchange like exchange of cultural, tradition takes place in this area. Only minority people think it does not exist.

Table 6.8
State of reciprocal exchange

S.N.	Response	Number	Percent
1	Yes, it exists	108	87.8
2	No, it doesn't exist	10	8.1
3	Not responded	5	4.1
	Total	123	100.0

Source : Field Survey, 2015

Figure 6.7
State of reciprocal exchange

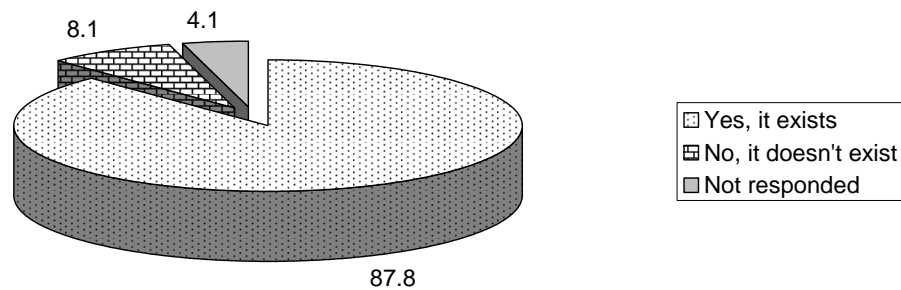

From the above data it is cleared that reciprocal exchange take place or exist in this area. The rate that the people thinks that it exist is around 87.8%. The minority people around 8.1% thinks it does not exist in this area.

6.9 The main things/goods exchanged

From my survey, the majority of the respondents exchange their goods with each other. The goods that they exchange are mainly many and household things. The majority people exchange the money while some exchange the household thing.

Table 6.9

The main things/goods exchanged

S.N.	Response	Number	Percent
1	Every households things	36	29.3
2	Money	87	70.7
	Total	123	100.0

Source : Field Survey, 2015

Figure 6.8

The main things/goods exchanged

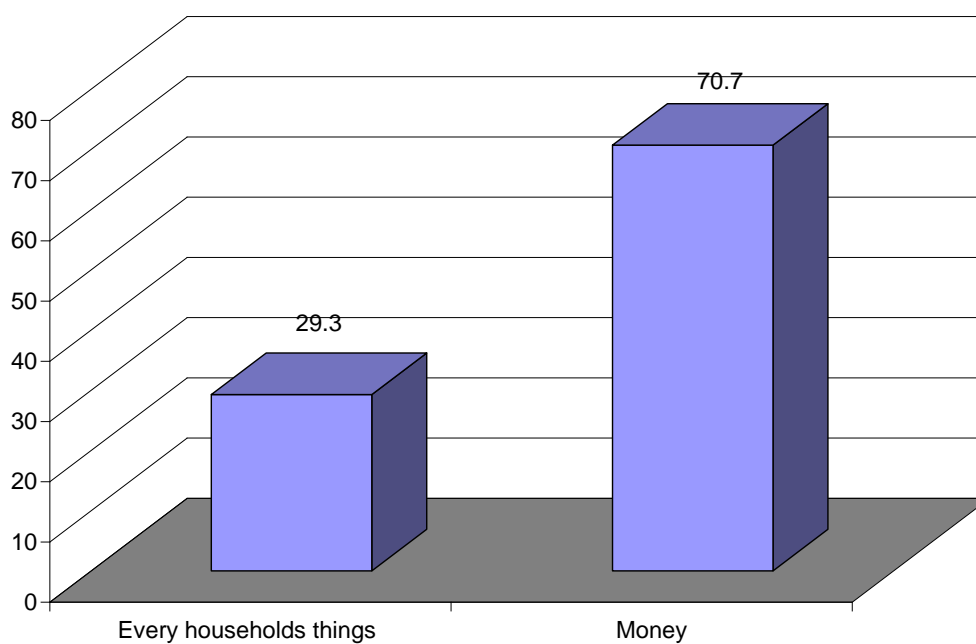

From the above table it is clear that around 70.7% of people exchange the money with each other when needed. Around 29.3% of people exchange their household goods or household material when they are referred.

6.10 Migrants food habit

When the people migrate from one place to another the focal habit in them rarely changes. Here also people in major thinks that the food habit is different that before while some thinks it is some as before.

Table 6.10
Migrants food habit

S.N.	Fooding habit	Number	Percent
1	Same as before	61	49.6
2	Different than before	62	50.4
	Total	123	100.0

Source : Field Survey, 2015

Figure 6.9
Migrants food habit

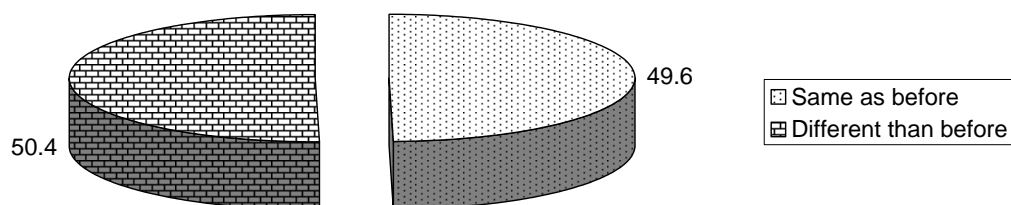

From above table it is cleared that high number of migrants thinks their fooding habits are different than they used to be the rate of this type of people

is half of the population i.e. 50.4%. But rest half of the people thinks they are some as before whose rate is 49.6%.

6.11 Migrants celebrate birthday

Nepal is a developing countries. Here people are not totally modified as compared to other developed country so the celebration of birthday is least in number. but in this area almost majority of people celebrate their birthday while some do not.

Table 6.11
Migrants celebrate birthday

S.N.	Response	Number	Percent
1	Yes	73	59.3
2	No	45	36.6
3	Unresponsed	5	4.1
	Total	123	100.0

Source : Field Survey, 2015

Figure 6.10
Migrants celebrate birthday

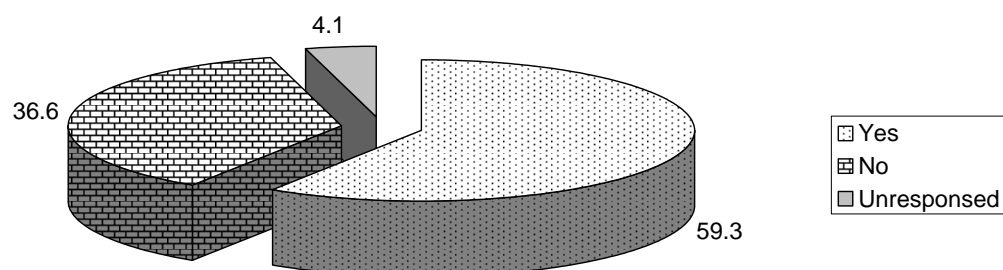

From the above it is clear that more people i.e. around 59.3% celebrate their birthday in this area while 36.6% do not. Almost 4.1% do not respond this topic.

6.12 State of traditional culture

When people migrate to new place the traditional culture do not changed as they are transferred to new place. Here in this area same thought i.e. traditional culture do not take place. But some of the people thinks they occur.

Table 6.12
State of traditional culture

S.N.	Response	Number	Percent
1	Yes	101	82.1
2	Changed	18	14.6
3	Unresponsed	4	3.3
	Total	123	100.0

Source : Field Survey, 2015

Figure 6.11
State of traditional culture

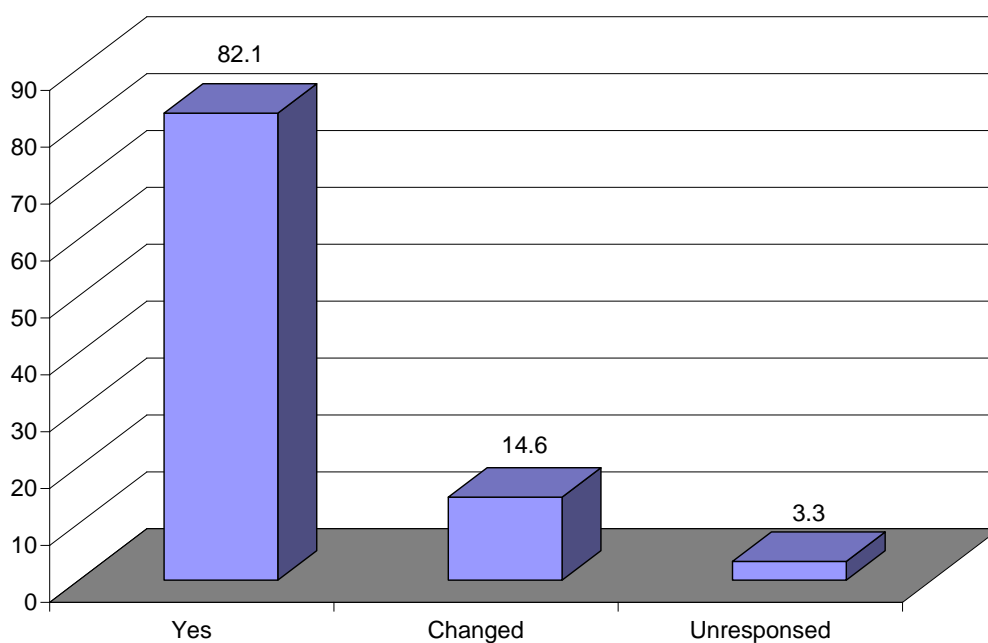

From the above table, we found out that traditional culture do not preferred as by the place in this area. Around 82.1% of people thinks that state of traditional culture do not occur. While 14.6% thinks the traditional culture occurred in this area.

6.13 Way of observing festivals in the festivals

Due to the high literate rate in this area people respect each other festival and celebrate together. Migrants here find out celebrating the festival together with local people while only some do not find that as they were expected.

Table 6.13

Way of observing festivals

S.N.	Response	Number	Percent
1	Yes	102	82.9
2	No	19	15.4
3	Sometimes	2	1.6
	Total	123	100.0

Source : Field Survey, 2015

From the above analysis more than half of the migrant that is around 82.9% thinks or find celebrating their each other festival to gather. But 15.4% of people do not get any help or do not want to celebrate festivals together from local people.

6.14 Differences between societies of before migration and this

From my survey, the societies have been changed before and after the migration. The change that occurred are in different field like infrastructure,

behavior and many more. Here in this area the migrant mainly found out difference in the behavior of the people and the facilities.

Table 6.14
State of traditional culture

S.N.	Response	Number	Percent
1	Can't say	25	20.3
2	Before village but now city	6	4.9
3	behavior of people	24	19.5
4	Easy to get help	2	1.6
5	Less facilities than before	2	1.6
6	More educated society than before	2	1.6
7	More facilities	26	21.1
8	More helpful neighbours	2	1.6
9	Not any	6	4.9
10	Not discrimination as before	2	1.6
11	Same as before	26	21.1
	Total	123	100.0

Source : Field Survey, 2015

From the above analysis, about 19.5 people found positive change in behavior of the people as compared to before. The majority change that they found after arrival in this area is the facilities. Around 21.7% people found out positive change in the facilities in this area.

CHAPTER VII

SUMMARY AND CONCLUSION

7.1 Summary of findings

This present micro level study attempt to analyze the pattern of cultural exchange between the migrants and the locals and to asses the mode of social interaction between migrants and local people in the context of Chhorepatan sub metro Politian city. A simple qualitative approach has been adopted in the analysis instead of sophisticated statistical tools for the achievement of the above objectives. Basically, descriptive analytical research design had been used. The analysis was adequately supported by illustrations.

Initially most people have been migrated to this area due to infrastructures of development, due to their relatives and for the easyness. Before 1979 the human population in Chhorepatan was relatively small but after 1979 the human population in this area has been rapidly increased and is going on. the marginal population in this area have been divided into many sub castes where Brahmin, Chhetri and Gurung are high in number which were mainly migrated from Syangja, Parbat and Kaski respectively. So the situation has changed and different people from different regions have migrated in this area and this study area is developing towards urbanization process.

The origin of respondents was different 3 districts. Among the three districts the respondents 26.8% came from Kaski, 16.3% came from Parbat and 48.0% came from Syangja. The trends and volumes of migration is mainly from adjoining hill villages.

The main pull factor in the study area were opportunity available for better facilities 31.7%, presence of relatives 33.3% and easy settle 35%.

Beside the social and cultural interaction between local and migrant age group also played significant determinant a migration. The migration was high in age group 26-35 (30.9%) followed by age group 36-45 (21.1%) age group below 25 years (11.4%) and age group 46-55 (15.4%) 56-65 years were 9.8% and 60 or above years were only 4.1%. Therefore number of adults migrants was found higher than the young and old.

In the study area an overwhelming majority of migrants were found relatively better in the condition of all basic needs such as infrastructure of development (education, health, transportation etc) drinking water, population and others.

7.2 Conclusion

Different positive and negative impacts are seen on the society when people migrate from one place to another. It is seen that majority of people are migrating from rural areas to urban areas. People have been migrating from one place to another for having better quality of life and for the search of better opportunities. A society can be divided in the two categories where of them is the migrants and the other are the local residents. We can also observe some distinct differences among them. Due to migration there exists drastic changes in the social, economic and cultural aspects of study area.

From 1979 the migration took place in the study area where people mainly from rural place migrated to this area for the good and secure facilities. The

majority people around 485 from Syangja migrated to this area, 26.8% migrants from Kaski migrated to this area. People from Parbat holding 16.3% migrate to this area in search of good facilities.

People living in Chhorepatan are divided into various cast and ethnicity, family size, age and sex respectively. The majority migrants in the study area according to age group holding 30.9% is adult group (26-35). People in this area are highly qualified. Literate rate in this area is marginally high in number which is 33.3%. People in this area is highly involved themselves in various occupation such as business (27.6%), laboring (1.6%), farming (6.5%) and involvement in various services (26.8%). People living in this area are mainly retired Indian army. They are categories in different religions such as Hindu Buddhist.

These studies show that drastic change had been seen due to migration. The main and major change that take place in this area is incensement of population growth due to which their exists changes in the intra structure of the development four the fulfillment of the basic needs.

REFERENCES

- Acharya, Binod Bhakta (2000). Immigration in Nepal: A case study of Byas Municipality, Unpublished M.A. Thesis, Submitted to Geography Department, Prithvi Narayan Campus.
- Adhikari, J. (1996), The Beginnings of Agrarian Change : A case study in Central Nepal, Kathmandu : TM Publications.
- Bhandari, Govinda Hari, (1991), In migration pattern in Sisuwa Gaun Bikas Samiti, Kaski, Unpublished M.A. Thesis, Submitted to Geography Instruction Committee, T.U.
- Bogue, D.I, (1969). Principle of Demography, New York : John Wiley
- GC, Basanta Bahadur (2008). "Rural Urban Linkage in Kaski District with special reference to Pokhara and Pundi Bhumdi". Unpublished M.A. Thesis, Submitted to Geography Department, Prithvi Narayan Campus.
- Giddings, Anrthony (2001). Sociology 4th Edition. Migratory Movements.
- Gurung, Lekh Bahadur (2001). Out migration and its impact on Social cultural environment in Karapu VDC Lamjung, Unpublished M.A. Thesis, Submitted to Geography Department Prithvi Narayan Campus.
- Kattel, Anjita (2006). Socio-Economic Impacts of Labour migration on the family : A case study of Bhalam VDC in Kaski", Unpublished M.A. Thesis, Submitted to Sociology and Anthropology, Prithvi Narayan Campus, Pokhara.

- Kharel, Beena (2005). "Substance of Remittance". The Kathmandu Post. Daily Newspaper, 20th January
- Kunwar, Laxman (1993). "Causes and consequences of Internal migration in Nepal : A Case Study of Bharatpur Municipality, Chitwan" Unpublished M.A. Thesis, Submitted to CDPS. TU.
- Nawin Kumar Pyakural (1978). "Migration and Income" A case study of Satdanda village Panchayat Unpublished M.A. Thesis, Submitted to Institute of Humanities and Social Sciences Economic Department, T.U. Kathmandu.
- New Era (1981). Internal and Inter regional migration. Kathmandu : New Era October.
- Poudel, Sanjay (2012). In migration Situation in Rajahar Village Development Committee, Nawal Parasi". Unpublished M.A. Thesis, Submitted to Department of Sociology Anthropology, Prithvi Narayan Campus, Pokhara.
- Rao, C.N. Shaner (199). Principles of Sociology with an introduction to social thought Published by S. Chand and Company Ltd.
- Ritzer, George (2000). Classical Sociological Theory 3rd Edition PP. 9
- Shakya, S. (2009). *Unleashing Nepal : Past, Present and Future Economy*. India : Penguin Books.
- Srivastav, Kamal Shanker (2002). Principles of Sociology, Publish by S.B. Magia 435.

Timilsina, Krishna Prasad (2007). "Rural Urban Migration and Livelihood in the informal sector. Unpublished M.A. Thesis, Submitted to Geography Department. Trondheim Norway.

Todaro, M.P. (1969). A Model of labour migration and urban employment in less development countries" American Economic Review. Vol. 89.

Wiether, Myron (1971). The Political Demography of Nepal. Seminar on Population and Development CEDA.