

Chapter I

Introduction

Background of the Study

New technology seems to have a growing impact on school, and it will probably more and more be incorporated within school practice. This makes it urgent to identify the crucial points according to which one might organize the use of computers and related new technology in education performances. It is important to understand how technology influences education and why. Mathematics in education is related to technology and technology to mathematics, thus deep knowledge of the influences of information communication technology on mathematics learning attracts high interest (Fuglestad, 2006). ICT based learning into conventional secondary education are the new practices to address the access and *quality* issues in this 21st century. Government and private institutions need to ensure to meet the expectation of students and the requirements of employers. Due to the use and application in ICT are becoming essential part of education at all levels in Nepal as well.(Dhakal, 2014).

Council for Mathematics Education recommended that ICT should be used in mathematics teaching because it encompasses skills and concept which are an important part of mathematics knowledge. Furthermore, it helps people to adapt to changes unexpected problem in their careers and other aspects of their lives. More recently the council endorsed with the statement that ICT should underlaygo on all aspects of mathematics teaching in order to give students experience of the power of mathematics in the world around them. They saw ICT techniques as a vehicle for student to construct, evaluate and refine their own theories about mathematics and the theories of others.

Like the change between an informal practical situated mathematics to a formal, generalized mathematics the inclusion of technology such as geometry software (example include GeoGebra, Mathematica etc.) may induce qualitative new aspects on its education. ICT may serve as a tool for learning powerful mathematical concepts, for getting insight and understanding and to do problem solving. A critical issue is how this function may be started and sustained. What are organizing matters, what are obstacles, what goals may be obtained and what are indicators of reaching at specific goals.

In this rapidly changing environment, education should change as quickly as the technology does. According to Fluk (2010), the future of Information, Communication and Technology (ICT) should play as a transformation role in education rather than integration into existing subject areas. The transformative view of ICT in education requires us to examine what new ways of pedagogies and curriculum are appropriate for a new generation working with new tools.

In this era the information technology has made its access to every field of life. The use of information and communication technology in education is growing admittance to information, educational products and overall perspectives, which are coming to form a globalized information network. Entrance to the technologies is a prerequisite for partaking in a global information society. So for the obvious reasons students/ individuals and instructions that are competent to access and joined in these global networks are at an advantage.

According to L97 (KUF,1999) students should develop independence and self-reliance in their learning. Self – regulated learning seems to be an interest in many subject areas in general and in mathematics education. The students are active take responsibility and organize their problem solving. Development of self-regulated learning and power to build their own knowledge and self- reliance is an important goal for the students. To use appropriate technological tools that students can judge as appropriate in different tasks, is part of this goals.

Literatures had shown that the advancement of computer has brought great innovation and thus school teachers need to be component in using computers so that they would maximize its use in teaching and learning. In addition NikAzis (2008) distinguished that the use of ICT has to be integrated in mathematics curriculum in both formal and informal ways and not just make it as an extra component. By integrating ICT into their everyday teaching practice, teachers can provide creative opportunities for supporting students' learning and fostering the acquisition of mathematical knowledge and skills (Hohenwarter and Hohenwater, M. & Jones K., 2007).When technological tools are available, students can focus on decision making, reflection, reasoning and problem solving. Students can also benefit in different ways from technology integration into everyday teaching and learning. For example Hollebrands (2007) highlighted that new learning opportunities are provided in

technological environments which potentially help students to engage with different mathematical objects and level of understanding. ICT also adds a new dimension to the teaching and learning of mathematics by helping students to visualize certain mathematics concept. Van Voorst (1999) and Hohenwater (2009) claimed that the visualization and exploration of mathematics objects and concepts in multimedia environment can foster understanding in new ways.

Statement of the Problem

Mathematics plays an important role in our everyday life. For this reason, the National Education System Plan (1971-1976) has emphasized in making the mathematics teaching life oriented and practical. Most of the school in Nepal is still using the traditional methods characterized by mastery of subject matter through drill, repetition and memorization. Few textbook, Marker and Board are use as the main instructional materials. NESP-1971 has emphasized on making mathematics life oriented and practical by introducing revised content, textbooks, and supervision system. In order to make geometry teaching conceptual, practical, the teacher expected to use the ICT properly. Hence, this study intends to study on effect of ICT in teaching geometry, at secondary level.

ICT play significant role in transferring basic knowledge to its application sectors eradicating the misconceptions about geometric concepts related to theorems proving. A review of the literatures indicates that ICT may serve as a tool for learning powerful mathematical concepts, for getting insight and understanding and to do problem solving. Due to the use and application in ICT are becoming essential parts of education at all level in Nepal as well (Dhakal, 2014). ICT play as a transformation role in education rather than integration into existing subject areas (Fulk, 2010). ICT helps to develop the communities for learning with technology (Fuglestad, 2003). ICT can have positive impact on teaching and learning (Eid, 2014). In short, good policy and management for updating ICT as teaching materials has positive impact on student's achievement improved perception toward learning geometry. So, an experimental conducted to see the effects of ICT on the academic achievements of students as compared to the traditional method of teaching in geometry at grade nine. So, this study focused on the answer to the following questions:

- Do the use of ICT affect in teaching geometry?
- Does the use of ICT yields better attainment of students than without using these?

Objectives of the Study

The main objectives of this study were as follows:

- To find the effect of ICT in teaching geometry in secondary level.
- To explore how ICT affects students confidence in the classroom.

Hypothesis of the Study

In this step hypothesis was constructed to test the correlation of variables according to the necessary. Hypothesis was cleared the structure of statement and was fix the direction of data collection process. For this study hypothesis was formulate as follows:

Research Hypothesis

The mean achievement of the students taught by using ICT is higher than mean achievement of the students taught without using ICT in teaching geometry.

Statistical Hypothesis

The following statistical hypotheses were formulated:

- H₀: H₀: $\mu_1 = \mu_2$, where μ_1 and μ_2 are mean achievement score of experimental and control groups on pretest.
- H₁: H₁: $\mu_1 \neq \mu_2$, where μ_1 and μ_2 are mean achievement scores of experimental and control groups on pretest
- H₀: H₀: $\mu_3 = \mu_4$, where μ_3 and μ_4 are mean achievement scores of experimental and control group on posttest.
- H₁: H₁: $\mu_3 \neq \mu_4$, where μ_3 and μ_4 are mean achievement scores of experimental and control group on posttest.
- H₀: H₀: $\mu_5 = \mu_6$, where μ_5 and μ_6 are mean achievement scores of experimental group on pretest and posttest.

$H'_1: \mu_5 \neq \mu_6$, where μ_5 and μ_6 are mean achievement scores of experimental group on pretest and posttest.

Significance of the Study

There are many new changes and challenges that teachers face, and are required to adapt to new methods of teaching and learning an increase in students numbers, and an explosion in the development of teaching with ICT. All of this means teachers need to update their knowledge and skills to develop the educational process in the classroom.

Many of these studies have provided evidence of the significant contribution that ICT makes to improving methods of teaching and positively impacting the learners. The presence of ICT in the interactive educational environment can help to develop thinking skills and make classrooms an environment for educational growth. ICT also helps students to develop new thinking skills which may transfer to difficult situation which may require analysis and comprehension skills; and consequently critical skills development. So, this study will help to support for mathematics teachers, schools, curriculum designer and policy makers as described below:

- **Mathematics Teachers:** Finding of this study will provide important information to the mathematics teachers about student's learning processes by the way of visualizations and to choose the best way of teaching geometry. In addition, to improve their teaching strategies.
- **School:** School can utilize the results to provide support and training to teacher on the use of ICT in teaching mathematics.
- **Curriculum Planer:** This study will help curriculum planer to find the important of ICT in teaching geometry at class nine and teacher guide prepared by the Ministry of Education for math book to emend curriculum research material in reference with ICT.
- **Policy Makers:** This study will support to the policy makers for integrating ICT in mathematics teaching and learning.

Delimitation of the Study

According to the interest of researcher, it is impossible to complete a research without maintaining all process. Sometime researchers will be unsuccessful to take pretest and there is difficult to divide the experimental and control group. Also it is difficult to control the external variables in experimental research. In this situation research cannot success to meet the conclusion. So delimitation should help to binds the study area to success the research which researcher wants to find out. This study will be limited in the following areas:

- The study was conducted with the experimental and control group of the students of grade nine of Kathmandu municipality.
- Only two public school were selected by purposive sampling method one for experimental and another for control group.
- This content coverage was limited to geometry of grade nine.
- The study was focused on using Projector Power point, Computer and GeoGebra software as ICT tools.
- This study was an experiment of 25 lessons.

Operational Definitions of the Related Terms

Some terms related to this study were defined. The definition were operationalize in the research context by consulting the literature. The key terms of this research were defined as below:

ICT: It stands for "Information and communication technologies". ICT refers to the use of projector, computer while teaching geometry.

ICT Based Teaching: It refers to use of ICT to present, drill and practice for theorem proving and problem solving activities as well as simulation activities in teacher learning process.

GeoGebra: It is a free, multi-platform, open-source dynamic mathematics software suitable for learning and teaching of mathematics. It combines geometry, algebra and calculus into a single easy to- use package that are dynamically linked.

Effectiveness: Effectiveness refers to improvement student's test scores and positive perception toward ICT based teaching

Achievement: It refers to the score obtained by the students on the achievement test prepared by the researcher.

Attainment: It refers to the active participation in classroom, homework and other activities in mathematics classroom.

Active Participation: It refers to the students regularity, doing classwork and homework

Experimental Group: A group of students, which is explored and use of ICT regularly. While teaching in geometry class.

Control Group: A group of students who were regular instruction in theorem proving of geometry, without using ICT.

Traditional Method: Traditional method represents a teaching strategy in which represents a teaching strategy in which the teacher constructs and organizes the subject matter and exposes everything by him. The teacher uses lecture method of teaching the teacher is main actor and could be taken as the teacher centered method.

Chapter II

Review of Related Literature

The review of literature involves the systematic identification and analysis of documents related to the study under taken. Scientific research much base on past knowledge. The present studies is considering as milestone for the study. Review of some related literature is cited below:

Rohani(2015) did a research on "The Effects of Geogebra on Mathematics Achievement: Enlightening Coordinate Geometry Learning indicated that there was a significant difference between the mean of the students' score on the post test in favor of the Geogebra group. 60 students were randomly selected with 27 for GeoGebra group and 26 for Conventional group. Mean, Standard deviation and t-test were used as statistical tools. He found that positive impact of utilizing mathematical learning software thus enhancing students learning and understanding. If clearly demonstrated the instructional effectiveness of GeoGebra as compared to the traditional construction tools. This study gave an alternative to the teachers to utilize Open Sources Software (OSS) as a tool in their instructional activities.

Eid (2014) conducted a doctoral dissertation entitled "A study on the use of ICT in Teaching in Secondary Schools in Kuwait". A mixed research methodology was employed in this study. 18 schools used in the research project. The research had distributed the questionnaire to 331 teachers over the 18 schools, and the researcher had met 16 participants, fourteen of them teachers and two of the policy makers in the Ministry of education. Mean, standard deviation, mode and rank were used as a statistical tool.He summarize that teachers clearly believe that ICT can have positive impact on teaching and learning. The research describes a situation where students are confident in their home use of ICT as a learning tool. The researcher suggests that increased confidence in ICT could be linked to increase positively about the impact and benefits of ICT.

Dhakal (2014) conducted a research entitled "ICT in Mathematics: Access and Quality in Higher education". In his research, questionnaire students were asked to indicate whether the application of computer and ICT-related facilities in their subjects to enhances the quality of their learning. The twenty two questions on this

category were collected together defined according to "if the score falls below 22, the belief is low, if the score falls in between of 22 and 44, there is moderate belief and if the score falls above 44, there is high belief.

The result indicates that a high proportion of semester -on students (95%) definitely agree that learning with ICT enhance access and quality. He found that the level of ICT knowledge in terms of use and access in M.Ed. mathematics students in T.U. are moderate. The perceptions and benefits of students regarding use of ICT in teaching and learning mathematics in TU is very high.

Drijers, Monaghan, Thomas, Trouche (2012)' Use of Technology in Secondary Mathematics' addressed the student learning often use a particular type of technology with one or more students working on tasks in manner indicated by a theoretical framework. Then look for some indication (such as engagements) or measure of improved learning outcomes. The most common interventions have involved the use of handheld graphing (GDS) or computer algebra system (CAS) calculators, although computer based CAS is also used. All forms of digital technology concluded with, "Educational technology is making a modest difference in learning of mathematics. It is a help, but not a breakthrough." They concluded that teacher is key to the successful use of digital technology in the mathematics classroom for the effective teaching. They claim that the term "ICT integration" can be considered misleading, suggesting that there is some permanent entity to which technology has to be integrated.

Keith (2011) conduct research entitled "The values of learning Geometry with ICT: lessons from Innovative Educational Research. He creates a framework of teaching approaches with geometry software as follows.

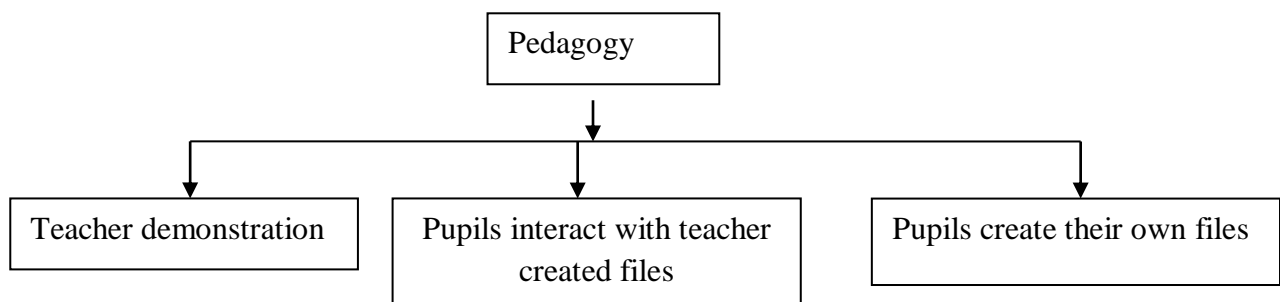

(Figure 1: Framework of teaching approaches with geometry software)

The main message of this research is that the undoubted and so far unparalleled, affordances of ICT, must be measured against the complexity of classroom learning, the demanding role of the teacher and the need for well-turned relevant professional development opportunities. While, access to computing power may shortly no longer be a source of an unbridgeable 'digital divide' differential access to networks of people that provide supports for educational innovation via ICT may be emerging new form of 'digital divide'. He focus the use of interactive software, the design of appropriate teaching and learning activities, and the nature of suitable teacher professional learning and development and this is matched by supportive institutional and national policies. Then the potential of ICT to enliven mathematics teaching and learning may be more likely to reach a 'tipping points' and move the pathway of education to a radically new route.

Amina (2003) conducted a doctoral dissertation entitled "Effectiveness of ICT in Mathematics at Secondary Level". To conduct the research three different schools from public, garrison and private sectors of Islamabad respectively. A sample of sixty students, having equal number of male and female students studying mathematics in class IX, was randomly selected from every school out of one hundred and eighty students. Students of every sample school were divided into equal groups. i.e. experimental group and control group. Every group contained thirty students, which further divided into equal number of male and female students. The students of experimental group were exposed to the teaching through ICT, where as the students of control groups were taught through traditional method of teaching in the subject of mathematics.

In order to achieve the objective of the study, t- test and Analysis of Variance (ANOVA) were applied through the SPSS Software to the mean score of the students obtained from posttest. The result was found that the effectiveness of ICT against traditional method of teaching in the academic achievement in mathematics at secondary level. It showed that ICT was more effective for female students in the academic achievement in, mathematics at secondary level in contrast to traditional method of teaching. ICT was least effective for students of low ability level in the academic achievements in mathematics against traditional method of teaching at secondary level.

Fuglestad (2003) concluded that a research study entitled "ICT and Mathematics Learning" shows that professionals reflect critically on and inquire into aspects of their professional lives, issues are revealed, questions refined and socially significant action cannot be taken in a clearly directed and knowledgeable manner. This ICTML project will be a large scale inquiry involving professional teachers, dedicated and researchers in inquiry at some level. At any level, those involved will engage in inquiry to their own particular roles, aims and expertise. This project involves researching aspects of students learning with ICT and use of ICT as support for teaching. In close co-operation with researchers in other areas of faculty, they will also study very nature of inquiry as a means of sustained effective education development in mathematics. He focuses the developmental research involving personal technology may form a basis for further planning of teaching environment and material. Also ICT helps to develop the communities for learning with technology.

Cambridge and others (2002) analyzed ICT and Mathematics: a guide to learning and teaching mathematics (11-19) summarize that the suitability of accommodation varies considerably; a minority of schools have good levels of high quality accommodations, equipment and software, for both schools have subject specific purposes. Many schools, however, find it difficult to complement ICT lessons by sufficient use of ICT in other subjects. Teachers are becoming skilled in setting up such arrangements, but there remains a considerable variation in how well the pupils learn when working computers. It is also concluded that care of teacher ensures that pupils understand what standards have to do and what they have to learn.

Keith (2002) 'Issues in the teaching and learning of geometry' suggests that it is likely to be meaningful to introduce various functions of proof to students more or less in the sequence as shown in figure:

Explanation \Rightarrow Discovery \Rightarrow Intellectual challenge \Rightarrow Verification \Rightarrow Systematization

(Figure 2: The likely learning sequence of functions of mathematical proof)

He defines geometry is the part of the mathematics curriculum where it is possible to have the most fun. It should be visual, intuitive, creative and demanding. Increase the use of imagination creates the striking classroom displays, suspend

geometrical models, from the ceiling of classroom, involve pupils in making things and imagining things, get them decide on definition and then explore the logical consequences. He defines the new developments in computing technology as one of the spatial thinking and visualization is vital in a 21st century. Geometry is where those are important skills are natured.

Theoretical Review

Learning theories provided us with conceptual frameworks of interpretation for the solutions to practical problem. Teaching methods were in the main based on theories were behaviorism and constructivism. These two approaches were based on two main schools of psychology that have influenced learning theory. They had different perspectives on learning, different perspectives on teaching styles and different approaches to pedagogy and evaluation.

Constructivist learning theory views that learning as a process in which the learner actively construct or builds new idea or concepts based upon current and past knowledge is known as constructivism. In other words learning involves constructing one's own experiences. Constructivist learning where internalized concepts, rules and general principals may consequently be applied in a practical real world context. This is also known as social constructivism. Social constructivism posits that knowledge is constructed when individuals engage socially in talk and actively about shared problems or tasks. Learning is seen as the process by which individuals are introduced to a culture by more skilled member.

Constructivist learning theory had been used to study the impact of ICT on teaching and learning. This learning theory contributed to understanding both the construction of and relationship between curricula and events. It also provided direction for research and implementation. Because of the influences of the constructivist learning movement, the theory of constructive learning emphasis the teachers central role in academic curricula and suggests improvement according to the teachers needs and interest. This theory supported the individual's growth and enables the students to explore their learning potential. Despite the theorist's different definitions of learning, a majority are agreed that learning happens when experience leads to a constant change in the individual's knowledge or manner. What is meant by

'experience' in this definition is ' interaction of the person with his or her environment '(Woolfolk, 2006: 196)

The proposed model applies and combines Constructivism and Conversation theories in learning environment, in which the students is an active maker of knowledge. In the proposed model a variety of learning activities and scenarios, differentiated for working students and regular students are applied, supported by innovative ICT tools, which facilitate applying Constructivism and Conversation theories and increase the level of communication and interaction between students; as a result, learning quality, experience and outcomes are increased effectively (Ahmad A. H. & Jeanne S., 2001).

Constructivism argued that autonomy and active participation of the students. The learner was an information constructor and actively built his/her own subjective representations of reality. New information was related to previous knowledge in terms of schema development. Constructivist learning theories range from the individual and personal constructivism of Piaget, to the social constructivism of Vygotsky. The use of ICT enables opportunities for learning environment and practices that require interaction among individuals, co-operation with chances to experiencing learning and the principles which constructivism supports. Hence, active learning, discovery learning and knowledge buildings is part of constructivism. Students were free to explore their learning within the prescribed framework and structure. They explored and constructed their own knowledge by solving realistic problems.

According to the theory of constructivism, knowledge is not taught but is learned by the learner themselves through constructing new knowledge on the bases of past knowledge. The students were also actively engaging in the process of scaffolding as they brought assistance from more advanced students in their geometry class. Students being the center of teaching and learning process while teacher works as organizer, facilitator and motivator. Psychologist Richard Gregory (1970) argued that perception is a hypothesis, which is based on prior knowledge. In this way students are actively constructing own perception of reality based on environment and stored knowledge. Thus the result of this study was supported by the design of the constructivist learning environment.

Constructivism was used in this research study as a theory to guide understanding of how students acquire new knowledge about theorems proving in geometry. According to Johnston and Ng'ambi (2006) argued that constructivist learning environment (Learner-centered) as an effective complement to the traditional learning environment (teacher-centered) in which, the role of the teacher shifts from being a source of knowledge to facilitating learning. Moreover, when learners are given the opportunity to engage actively in processing of prior knowledge with new information they construct new meaning.

Conceptual Framework of the Study

Conceptual framework had been developed on the basis of the previous researchers and studies carried out in the similar topics. In this regard, the researcher has consulted researches of various writers and researched. The idea can be present in the following framework:

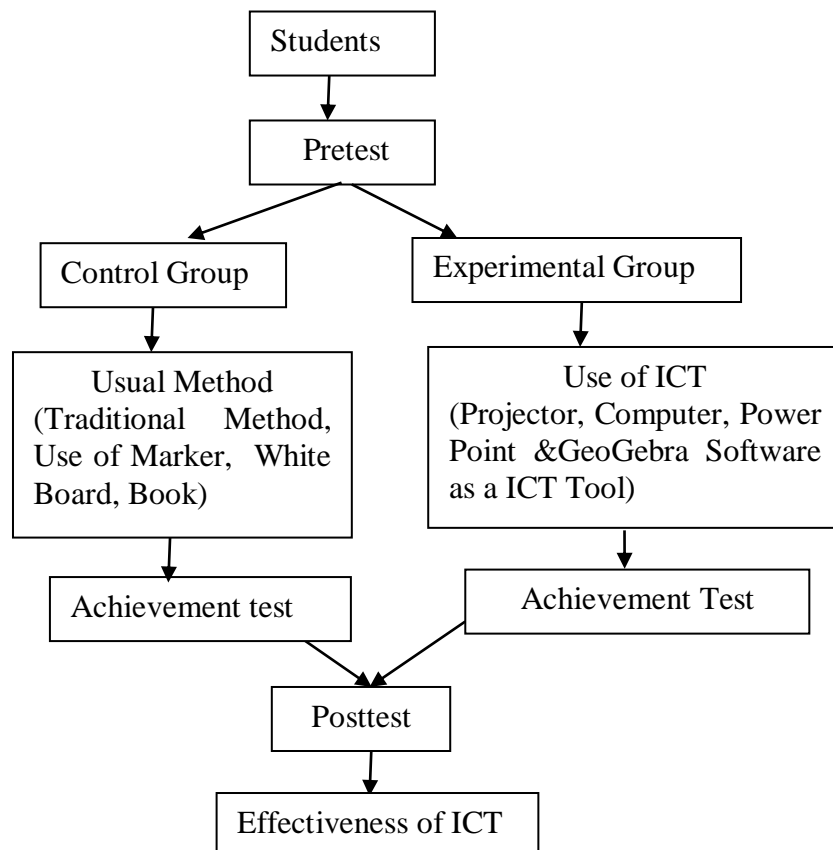

(Figure 3: Framework of effectiveness of ICT in teaching geometry at grade nine)

In the initial phase of learning content was presented by power point and students were encouraged for questioning and recalling preliminary information related to concept. Then students were asked questions related to the presented topics.

Also power point was used for the purpose of visualizing the steps of theorems proving which was appeared in the construction phase. Finally, assessment and reflection on the solution helps to generate new knowledge and concepts. However, It should be noted here that, contents was presented first. And then next steps were followed by the questioning and recalling the information allied to the problems. In sum, conceptual framework for this experimental setting is designed in the above diagram on the basis of constructivism approach of learning. It provides direction for research and implementation.

Chapter III

Methods and Procedure

This study entitled "The effectiveness of ICT in on teaching geometry at grade nine" was essentially experimental in nature. It was design to examine the effect on ICT on geometry teaching. This chapter incorporates research design, population of the study, variables study, data collection tools, data collection procedure and analysis procedure.

Research Design

The design of this study was experimental in nature (nonequivalent group design) based on pretest, post-test, non equivalent control group design along with quantitative data for the purpose of the research.

Table 1: Design of the Study

Group	Pretest	Treatment	Post-test
Experimental	T ₁	ICT based	T ₃
Control	T ₂	Usual Method	T ₄

Where, T₁ and T₃ are pretest and post- test given to the students of experimental group and T₂ and T₄ are pretest and posttest given to the student of control groups respectively. For this, the researcher used 5 point Likert scale. This design was one of the most effective in minimizing the threats to experimental validity. Two groups were made homogeneous as nearly as possible on the basis of pre- test result with the establishment of two non- equivalent groups, experimental and control. Experimental group was received the experimental treatment whereas control group was not receive it. Experimental group taught by using ICT and control group taught by usual method.

Population of the Study

This study conducted within Kathmandu district considering students from two public secondary schools for identifying the effectiveness of ICT in teaching learning geometry at grade nine and elicitation the student's perception in learning

geometry using ICT. Thus, all secondary level students those were studying a grade nine at Kathmandu was taken as the population of study.

Sample of the Study

This study experimental and was carried out two schools Shree Vaishnabi Secondary School, Kirtipur- 18 and Economics groups students of Mangal Secondary School, Kirtipur- 16, Kathmandu. These two schools were selected by the researcher because of access and expectation of help and co-operation need from the school. For the selection of students, first of all pre- achievement test was taken to the whole students of class nine of both schools. Two groups were made homogeneous as possible as on the basis of their pre-achievement scores. A fair coin was tossed to determine the experimental and control group. In this process, Shree Vaishnabi Secondary School's twelve students (seven girls and five boys) were selected and Mangal Secondary Schools thirty six student (twenty girls and sixteen boys) selected as a control and experimental group according to the coin toss.

Data Collection Tools

The researcher was developed two different teaching modules for each group every day teaching using by ICT and usual method of teaching for experiment. The achievement test paper was the main instrument for data collection of the study. Some question developed by researcher himself, some question taken from teacher's guide and specification grid of grade nine which published by CDC, Sanothimi Bhaktapur.

Achievement Test Paper-I (for Pretest)

An achievement test paper-I was consisted sixteen items. Among them eight was knowledge level question demands simple information carry 1 marks as score, the comprehensive level questions demands both information and skill, carry 2 marks each whereas the application type of questions were higher level which demands knowledge as well as comprehensive level of 4 mark each. The questions were selected from the unit geometry of grade six to nine from curriculum of Mathematics. This test was administrator on both groups at the initial stage to find the correlation between two groups. Also on the basis of achievement test paper- I, researcher was matched to equivalent of two groups.

Achievement Test Paper- II (for post-test)

An achievement test paper – II consisted of sixteen items in which eight were objective items of one mark, five were short type subjective item of two marks and three were long type subjective item of four marks. It contained the questions from the taught chapter as pretest and also length of the posttest was equal as the pretest. This test administrator on the experimental and control group at the final stage of the experiment.

Questionnaires

The students perceptionscale (questionnaire) was used to elicit student's perception in learning geometry using ICT. In this study, a set of questionnaire with 17 items was adopted and modified based on Shadaan and Leong (2013) study. Likert scale was used in the questionnaire, with option ranged from 1(Strongly Disagree) to 5 (Strongly Agree) for positive statement and for negative statement the scoring process was reversed (see Appendix-C).

Participant Observation

Observation is a kind of tool that helps to see knowledge through the use of sense i.e. eyes, ears, nose, tongue and skin. It had great importance not only in research work but also in our daily lives. Direct observation has the advantages of putting researchers into first hand contact with reality. Participant observation is a close and involvement of researcher in a natural setting in order to experience and understand the behavior interaction event and so on. It helps to bridge and share the intimacy between the researcher and the setting which is under study; by emerging researcher her/himself into the subject being study. Since the Nepalese classroom constitute by socio- cultural forces because students from different background have their own live reality and in the classroom difficult to conform norm and values of the school but also produce difference and these multiple realities influences the life in the classroom as well. To get require information the researcher observes school overall as well as key respondents individually and collectively during their work at school, classroom, playing with peers, interacting with teachers about 25 lessons.

Validity and Reliability of Tools

Since a tools are valid for particular purpose and particular group. Therefore, the mathematics achievement test and teaching modules were developed for measuring the problem solving performance as well as achievement of grade nine students. For this purpose test items were piloted and reliability was checked before it was administered. For that researcher was used 16 test items (8 knowledge level question, 5 comprehensive level question and 3 knowledge as well as comprehensive level question) from the text book of grade six to nine, then the set of test items was administered for the purpose of pilot test of group nine students of Janasewa Higher Secondary School, Kirtipur who were not included in the sample of the study. The estimation of the validity of this test the tools were developed with the help of mathematics teachers, supervisor and other educators. The teaching modules were constructed on the basis of ICT. The suggestion from experts and necessary changes were made to improve the tools for the immense of the validity. Therefore, it could be said that the tools were quite valid.

The reliability, Cronbach's Alpha coefficient of test items was calculated by using the statistical package for Social Science (IBM SPSS 21.0) version. In this study, the reliability coefficient of overall achievement test was 0.723 and content validity of the achievement test items was determined by the experts' Judgment.

In this study, a set of questionnaire with 20 items was adapted and which are modified based on Shadaan and Leong (2013) study used for students' perception on ICT in the learning of circle. A set of questionnaire was developed for the purposed of pilot test-then the questionnaire was administrated among the 36, grade nine of Mangle Secondary School, Kirtipur which group of students' were not included in the sample of the study.

Data Collection Procedure

Achievement test papers were the main tools of data collection for the study. The data for the experimental and control groups were collect from Shree Vaishnabi Secondary School and Mangal Secondary School, Kirtipur were respectively taught by the researcher himself. The experimental group was taught by ICT whereas control group was taught by usual method. Twenty-five lesson instructional activities were

carried out as regular school activities. At the end of instructional period, the achievement test was administered to both groups of the sample students. The post-test was contained same item but different test that was used in pretest. The answer sheets were collected and process manually by researcher himself. The score was tabulate and their mean and variance was calculated by using statistical formulae.

Stage of Experiment

This study was conducted in three stages:

Pre-Experimental Stage

In this stage, the subject experts tested reliability, validity and standardization prepare teaching episode. Also prepared and validity of achievement test paper. At last, the pretest was administered to the students to measure their achievement in mathematics in two schools and it was divided into experimental and control groups. This period had ranged from February 18, 2018 to March 16, 2018.

Experimental Stage

In this experimental stage, the researcher took geometry classes on the both control and experimental groups on behalf of proposed plan. On this stage the experimental group (Students of Mangal Secondary School) was taught theorem proving of chapters Triangle, Parallelogram and Circle with ICT and control group (Students of Vaishnabi Secondary School) followed teaching and learning session in the traditional teacher centered approach. This period was ranged February 19, 2018 to March 15, 2018.

Post- Experimental Stage

In this stage, posttest was administered after finishing the unit. The researcher himself was checked answer paper and analyzed the data with the help of statistical package for Social Science (IBM SPSS 21.0) version.

Control of Variable (Extraneous/ Confounding)

Since the experiment was conducted in two different schools. Each school of grade nine students was taught by using ICT and without these by researcher himself. In teaching activity there was attempted to control individual factors from which the

outcome might not be separate on other factors apart from the situation of teaching method. Students whom taught by some book, topic and equal time, they were got some homework and class task. There was not any discussion between two groups of students about of teaching methods each other because they were not having any relation with each other group. Similarly during experimental period both groups were controlled to take extra class, tuition and coaching class. Every group was involved boys and girls but they were not selected and equal. At this process, same achievement test was taken both group and use some scoring procedure.

Similarly, there were some intervening such as history, maturation, testing and mortality etc. which affected the outcomes largely. Some of them were controlled by special procedures and some of them were controlled by the design of the experiment. These variables were described below:

Independent Variable

The independent variable of the study was the treatments (teaching method) implemented, and had two categories as ICT based teaching and traditional method (without using ICT). For the control group not to use any technological tools that support or facilitate the learning process. Therefore independent variables which instructional methods were controlled.

Dependent Variables

Dependent variables of the study were the student's posttest score on Mathematics Achievement Test (MAT) and student's perception in learning geometry by using ICT.

Non- Experimental Variables

There were also common experimental variables such as teacher variables. The non- experimental variables such as teachers variable, subject matter teaching aids, length of experiment, evaluation apply, student and school environment was controlled in order to minimize the effect on dependent variables.

Method of Data Collection

The researcher developed the achievement test, teaching lesson plan and Questionnaire for the raw data collection. At first the researcher visited the school(Shree Vaishnabi secondary school,kirtipur-18, Kathmandu) and conducted the test in twelve students.

Then researcher taught them through tradition method. During this period researcher noted down the students understanding, participation, intrapersonal skills and performance accuracy in his daily note. A daily note based on the classroom reflection prepare by researcher facilities the data analysis and interpretation researcher was noted remarkable events found in the class of both groups. At the end of the study, Student had the standardized achievement test administered in both groups of the sample students.

This study based on the quantitative data obtains from achievement test. For this purpose researcher visitedthe sample school of Kathmandu district then researcher were select the two nonequivalent groups of grade nine students from the selected school with the help of head master and mathematics teacher to collect the required information. ICT used in the experimental group and usual method for control group. Both group were instructed for a time span of three week for each group and taught the same content to reach exactly the same objectives with different teaching method.

In the first phase of experiment students of both groups was administered pre-achievement test for the purpose of identifying the student's level in theorems proving of Triangle, Parallelogram and Circle and analyzed the results of pre-achievement test quantitatively. After three week of regular class similar but different test administrated both groups as post-achievement test to examine the effect of the ICT and results of the post-achievement test was analyzed quantitatively by using IBM SPSS 21.0.

Finally, researcher used questionnaire based on the five point Likert scale in experimental group students including the students perception towards the use of ICT in learning geometry. The questionnaire provided to the students individually and they were requested to tick on one of Strongly Agree, Agree, Neutral, Disagree and

Strongly Disagree. For positive statement Strongly Agree, Agree, Neutral, Disagree and Strongly Disagree implied 5, 4, 3, 2, 1 point respectively and for negative statement the scoring process was reversed. After collected the answered questionnaires, the response of the students were coded so suitably that it fitted with the statistical tests.

Data Analysis and Interpretation Procedure

To complete the objective of this study mathematics achievement test and set of questionnaires had used to obtain student's achievement score and to find out perception about the ICT. To analyze the data, it was necessary to organize the data by using computer and verbal data were converted in to numerical form. The achievement test scores were analyzed by using descriptive statistics. In descriptive statistics, the mean, standard deviation of the pretest and posttest scores of the dependent variables were computed for both experimental and the control group and then inferential statistics was injected. Especially, t-test was used to test statistical significance difference between the achievement of the students those was in the control group and experimental group at the beginning of the experiment and at the end. To purpose of analyzing the result SPSS 21.0 was used.

At first, independent samples t-test was conducted to determine whether the experimental and the control group differ significantly in terms of their mathematics achievement level in theorems proving related to the lesson Triangle, Parallelogram and Circle. Therefore pretest score of experimental and control group were compared. In second, independent samples t-test was conducted again to explore whether there was a statistically significant difference between posttest score of the experimental group after the treatment session ended. The hypotheses were tested at the significance level of 0.05 since it is mostly used value in educational studies.

There is wide variety of effect size measures around but the one was used in conjunction with the t-test is called Cohen's d. In this study the Cohens'd measure the effect size of differences between two groups on the basis of following guidelines (Daniel M, 2004).

0-0.20 = weak effect

0.21-0.50 = modest effect

0.51-1.00 = moderate effect

>1.00 = strong effect

Finally in order to identify students' perception towards learning geometry by using ICT was done by calculating mean scores and standard deviation of individual respondents on the perception scale. To achieve this numerical score were assigned to five points Likert scale, for all the positively stated statements the values given were as follows: Strongly Agree=5, Agree=4, Undecided =3, Disagree=2 and Strongly Disagree=1 and for negatively stated statements the scoring process was reversed. The data was analyzed by SPSS 21.0. Finally, the result was interpreted on possible pictorial graph using SPSS 21.0 and Microsoft Excel.

Chapter IV

Analysis and Interpretation of the Data

This chapter deals with the analysis and interpretation of data obtained from the student's achievement scores and perception scale of the sample students. The major function of this discussion is to interpret the result of the study. The main aims of this study was to compare the achievement score of students thought by ICT assist learning and expository learning method of teaching geometry (Triangle, Parallelogram and Circle) in this research. The strategy to answer the research question is based on making analysis of quantitative data collections from the appropriate data sources. In order to make the process of quantitative analysis easier the finding from the different data sources are first tabulated in the appropriate tables. For all statistical analysis the IBM SPSS 21.0 version were applied to analyze the obtained data and hypothesis were tested at the significance level at the 0.05.

The objectives of this research study were to compare students mean achievement of experimental and control groups in learning of geometry. This research was completed based on experimental design selecting two public schools at Kathmandu district. Mathematics achievement test and questionnaires were used as data collection tools extraneous variables were controlled as much as practicable. The data are organized and tabulated as below.

Achievement Score of Control and Experimental Group Student's in Pretest

There were 36 students in experimental group and 12 students in control group. In pretest 30 marks of mathematics achievement test was administrated in which pass marks were 10 (See individual score of the students in Appendix –F). Achievement test scores were calculated using IBM Statistical Package for Social Science 21.0 (IBM SSPS 21.0) which is presented in the table 2 below and detailed SPSS 21.0 result of pretest Appendix-F.

Table-2 Pretest Comparison Group Statistics

Group	N	Mean	Std.dev.	t-value	Df	P-Value
Control	12	13.917	4.714	-1.547	46	0.129
Experimental	36	16.611	5.376			

Table-2 showed the p-value was 0.129 ($p > 0.05$) which indicates that the differences in the mean score of the two groups were not significant in pretest score. It means calculated t-value is -1.547, which is tested 95% confidence interval having lower limit is -6.200 and upper limit is 0.811. Hence t-value is lying between $-6.200 < -1.547 < 0.811$ thus our null hypothesis there is no significant difference between the average achievements of the students those taught by ICT and without using ICT based teaching in pretest cannot be rejected. This result illustrates that both students in the control and experimental group were similar in abilities before the treatment was administered.

The graphical representation of the mean and standard deviation of the students of control group and experimental group shows that both group students are homogeneous in terms of their mean score in pretest.

Figure 4: Student's Achievement in Pretest

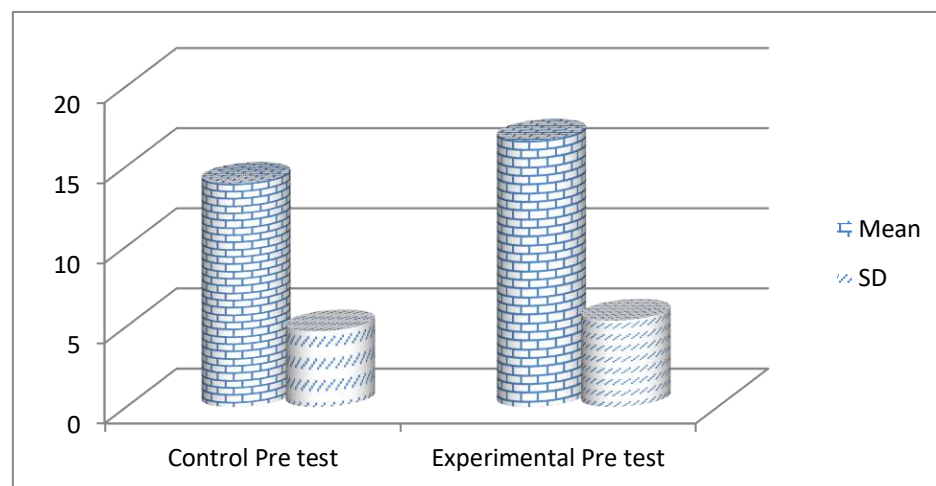

Achievement Score of Control and Experimental Group Student's in Posttest

To determine whether any significant difference exists between the posttest mean score of the control and experimental group, an independent sample t-test was carried out by IBM SPSS 21.0. The summary of student's achievement in posttest is presented in table 3 given below and detailed IBM SPSS 21.0 result of posttest see Appendix-H.

Table-3: Posttest Comparison Group Statistics

Group	N	Mean	Std. Deviation	t-value	df	P-Value
Control	12	15.458	4.943	-4.530	46	0.000
Experimental	36	22.694	4.744			

Table 3 showed that the p-value was 0.000 ($P < 0.05$) which indicate that the difference in the mean score of two groups were signification. It means calculated t-value is -4.530 at 95%. Confidence interval having lower limit is 10.451 and upper limit is -4.020, hence t-value is lying out of acceptance region, thus our null hypothesis there is no significance different between the average achievements of the students those taught by using ICT based teaching in posttest must be rejected. This shows that ICT based teaching provided positive impact on students test score in theorems proving of geometry with compared to traditional method.

This finding illustrated that the students in the experimental group performed better using ICT than the control group using without ICT (usual learning method). The students in the experimental group performed better in the posttest compared to the control group. Thus ICT is more powerful strategy to gain more achievement for student.

The graphical representation of the mean and standard deviation of the students of control group and experimental group obtained in posttest shows that mean score of experimental group students slightly higher than control group students in terms of their mean score in post-test.

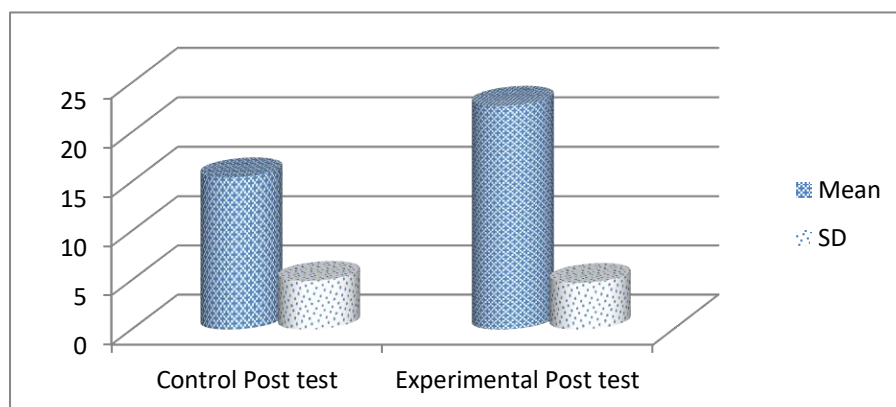
Figure-5 Student's Achievement in Posttest

Paired Sample Test: The table 4 Showed that the Result of Paired Sample t-test

Table 4: Result of Paired Sample t-test

Group	Mean	Sd	t	df	P-Value
Control Posttest score-Pre test score	1.542	1.437	3.715	11	0.003
Experimental Posttest score pretest score	6.083	2.729	13.373	35	0.000

A paired sample t-test was conducted to compare the pretest and posttest scores for control and experimental groups. The result as illustrated in table 4 shows for the control group the p-value obtained 0.003 which is less than 0.05, indicating there is significant difference between the pre and posttest score. So our assumption, there is no significant improvement in pretest and posttest scores of control group is rejected. For the experimental group, the p-value obtained is 0.000 ($P < 0.05$) indicating there is significant difference between the pre and posttest score. So, our assumption, there is no significant improvement in pretest and posttest score of experimental group is rejected. This indicated that there is a significant improvement in pretest and posttest score of experimental group is accepted.

From the result, it can be seen that students gained from both approaches but the students in the experimental group appear to have a higher mean difference or improvement in scores compared to the control group. The mean score of the experimental group increased more than that of the control group indicating that learner's performance in the experimental group improved more than in the control group. The standard deviation of the experimental group had a smaller increase as compared to that of the control group indicating that the gap between learners who understood theorems proving and those who did not was higher in the control group than in the experimental group. Thus, ICT is more powerful strategy to gain more achievement for students.

Cohen's d-test: The Table 5 Showed the Result of the Cohen's d

Table-5: Result of Cohen's d -test

Group	N	Mean	Mean Diff.	Std. dev.	d	Cohen's d
Control	12	15.458	7.238	4.943	7.315	0.989
Experimental	36	22.694		4.744		

Table 5 shows that the students achievement in posttest in terms of mean, standard deviation, mean score difference, score of Cohen's d . It showed that the control group obtained a mean score of 15.458 and SD is 4.943 while the experimental group obtained a mean 22.694 and std. dev. is 4.744 and the score of Cohen's d is 0.989, which lies between $0.51 < 0.989 < 1.00$. Therefore there is a moderate effect of ICT in geometry teaching. Because of limited in short time period the result found moderate effect. If this study was conducted for long period result must get strong effect. In conclusion, ICT has affected in teaching geometry of secondary level.

Result of Student's Perceptions in Learning Geometry by Using ICT

The students' perception was identified through a set of questionnaire based on five point Likert scale consists of 17 items. The questionnaire was distributed to the experimental group only to know their perception based on their experience using the ICT in learning geometry. The overall items have 0.723 as Cronbach's Alpha coefficient was carried out by SPSS 21.0. The results of students' perception are shown as table 6 below.

Table 6: Students Perception toward Geometry Learning Using ICT

S.N.	Items	Mean	Std.dev.
1.	I was excited while using ICT in learning Geometry.	4.06	1.040
2.	I learnt a lot of geometry concept using ICT software.	4.17	0.845
3.	Lesson with ICT is interesting to learn geometry.	4.31	0.822
4.	I felt confident to solve the problems using ICT.	3.97	0.810
5.	The lessons with the ICT help me to easily understand the theoretical part of geometric lesson. Triangle, Parallelogram and Circle	4.00	0.717
6.	I benefited a lot through the teacher student's interaction.	3.83	0.941

7.	I was able to visualize and answer the questions after each activity.	3.47
8.	ICT software can help increase my achievement in geometry.	3.56
9.	I can think creatively and critically when using ICT	3.50
10.	I enjoyed learning mathematics much more by using ICT.	3.28
11.	ICT encourage me participate in class activity.	3.56
12.	I need more time to learn theoretical part of geometric lesson by using ICT.	1.75
13.	It makes geometry class boring	1.39
14.	ICT enables me to get the idea of proof easier	3.75
15.	I was able to find the better connections between previous learning and new learning	3.81
16.	I was satisfied with the use of ICT in learning geometry.	3.89
17.	I would like to learn more geometric concepts using ICT.	3.61

Based on table 6, over all mean of items were 3.523 (See Appendix – K) which is higher than 3.0. According to the Kofi(2010), a mean score of 3.0 or higher indicates a positive perception toward ICT in learning geometry and the mean score lower than 3.0 indicates negative perception toward ICT. Results from table 6 also show that 16 out of 17 of the items had a mean score of higher than 3.0. It shows majority of students agreed with statements about ICT. Result from table 6 show that students generally gave positive response toward the ICT in learning geometry. The study found that items in the questionnaire that had the lowest mean was item 13 which stated that students make boring geometric class by using ICT with a mean 1.39. While the highest mean is 4.31 which is obtained for the 3 item: Lesson with ICT is interesting to learn geometry.

Based on the results in table 6, majority of the students have a positive perception towards ICT based learning. It is seen that more respondents believe that ICT based learning could generally provide better learning experience. However for a negative statement 'It makes geometry class boring most of the respondents disagreed and strongly disagreed with mean 1.39. Item Lesson with ICT is interesting to learn geometry shows that majority of respondents agreed and strongly agreed with mean 4.31. Similarly the items 2,3,4,5,6,15,16 show that majority of respondents agreed and

strongly agreed. They also enjoyed learning mathematics much more when using ICT and were able to form better connections between previous learning and new learning. It can be concluded that the using of ICT can increase students' Interest, confidence and their motivation in learning mathematics.

The finding from the questionnaire show that majority of students liked the geometry lesson with ICT. They are positive about the theorems proving using ICT. The ICT based teaching has also had a positive effect on the students' interactions with each other as well as with the teacher. In addition, from the students' discussion and interactions during the class it was noticeable that the ICT based teaching raised the students' interest and enthusiasm toward geometry.

Chapter V

Summary, Findings, Conclusions and Recommendations

This study was concerned the study on the effectiveness of ICT on teaching geometry at grade nine students. The main purpose of this study was to investigate the effectiveness of ICT in teaching geometry. The second purpose was to investigate the perception of students in learning geometry using ICT. This chapter starts with a summary of the major findings and the chapter ends with conclusion and recommendation for further research.

Summary of the Study

The result of the pretest of both groups indicated that was no significant difference and there was significant difference between both groups on posttest scores. The findings showed that the ICT based teaching as a supplement to traditional classroom teaching is more effective than traditional teaching alone. It clearly demonstrates the instructional effectiveness of ICT as compared to the traditional construction tools.

Using ICT to work with theorems proving provides many advantages to students. Students are able to generate fast, accurate and easy arguments. They may create their own conjectures and make construction with technology to write a proof or argument. In addition, researcher found that students in the treatment group were more engaged when they learned theorems proving using ICT as opposed to the control group who received traditional instruction.

The findings of the research also reveal that the use of ICT can provide rich mathematical environments in which students are engaged in classroom actively. It appears to have the potential to facilitate peer interaction, as well as to focus that interaction on learning. Findings from this study support previous studies to show that learning through ICT does give positive impact in constructing students' knowledge and understanding of theorems proving of geometry. Learning process underwent by experimental group also enable open communication between students and teacher, as well as among students themselves. By visualizing theorem proving steps, it helps those who are visual-spatial type learners better than rote learning process. In addition, the finding of this study is supported by Dogan, (2010) whereby it was

observed that computer based activities encouraged higher order thinking skills, and had a positive effect in motivating students towards their learning. Major finding of the study are stated below:

- There was not significance difference between the average achievements of control group students and experimental group students in pretest.
- Students in the experimental group scored significantly higher on the average than the students in the control group in post-test.
- Use of ICT has become effective than traditional method in order to learning geometry become of the improvement test scores and positive perception towards ICT of the control group student.
- The results show that ICT has positive effects on students' leaning and achievements.
- The result of paired sample t-test of experimental and control group was found significant.
- The results show that all most all students have positive perception of using ICT in geometry learning.

Finding and Discussion

The focus of this study was to discover effectiveness of teaching mathematics through Information Communication Technology (ICT) as compared to traditional method of teaching in topic of geometry at grade nine. The researcher had selected the two non-equivalent groups as the experimental and control group. After taken the pretest of both groups researcher taught for experimental group through ICT and traditional method for control group. Researcher applied the Questionnaire and Interview tool to get the strong data. Researcher found the mean difference score 7.236 after applying the ICT for experimental group and traditional method for control group. The mean score of pretest of experimental group was 16.611, which had increased tend to 22.694. But mean score of pretest of control group was 13.917, which has increased tend to 15.458 is limited increased to compare with the experimental group.

The p-value score of pretest group comparison was 0.129 ($p > 0.05$) which is indicating that the difference in the mean score of two groups were not significant in

pretest score. Also the p-value score of posttest group comparison was 0.000 ($p < 0.05$) which is indicating that the difference in the mean score of two groups were highly significant. This showed that ICT based teaching provided positive impact on students test score in theorem proving of geometry with compared to traditional method.

A paired sample t-test was conducted to compare the pretest and post test score for control and experimental groups. The result as p-value obtained 0.003 which is less than 0.05 indicating there is significant difference between the pretest and post test score. So our assumption, there is no significant improvement in pretest and post test scores of control group is rejected. For the experimental group p-value obtained 0.000 ($p < 0.05$) indicating there is significant difference between the pre and posttest score of experimental group. So our assumption, there is no significant improvement in pretest is rejected. This indicated that there is a significant improvement in pretest and posttest of experimental group is accepted.

The student's achievement in posttest in terms of Cohen's d is 0.989 which was lied between $0.51 < 0.989 < 1.00$. Therefore there is a moderate effect of ICT in geometry teaching. This shows that ICT has affected in geometry teaching.

Application of ICT as a teaching strategy in mathematics was found effective as compared to traditional method of teaching. So to enhance its use in other disciplines of education, the Integration of ICT might be introduces in all other subjects of the curricula taught at secondary and higher secondary levels. Computer software programs and on-line tutoring for all the disciplines taught at SEE and HSS level might be developed.

Reflection

It has been found that had taught through use of ICT assist learning is effective than without ICT assist learning in teaching geometry at basic level. Use of technology in the classroom is more motivated to the mathematics learning. Use of ICT in the classroom is effective tool than traditional method. Teacher and other respective person had motivated to apply the technology in the learning environment. Student prefers to use computer assist method to learn the geometry when they utilized ICT in geometry tasks. The computer method is completely new for student,

they has exposed to the traditional method. The various feature of the ICT like visual, dynamic help to the student to understand the concept in the depth. The immediate feedback is playing the very vital role in learning and students were very positive to learn of the geometry. ICT is the one of the tool which assists to the student in simple as well as different way. ICT can be useful as a mathematical tool that can integrate for teaching of mathematics at basic level.

Conclusions

In this study, the teaching and learning of theorems proving using ICT has established as effective method. The findings highlight that students in the experimental group performed better using ICT than the control group in which traditional teacher centered method had been used. The ICT also enhanced visualization and understates steps of theorems proving for students. Moreover, it is found that ICT based learning helped them to think creatively and critically in the process of discussion and elaboration and they were able to visualize abstract concepts related with geometry.

On the basis of above findings it can say that ICT has a positive impact on student's achievement in theorems proving of lesson Triangle, Parallelogram and Circle. An important consideration is to use technology to develop knowledge and ways of thinking well as help students move further in their understanding of core geometry concepts in addition; this study suggests that the use of ICT in the mathematics classroom is useful for helping student's performance better regarding theorems proving. Furthermore, students have a positive perception towards learning geometry in reference with use of ICT. Consequently, the ICT also encourages students to learn the theorems proving of lesson Triangle, Parallelogram, and Circle in more enjoyable and interesting way. Apart from this, ICT is the best tool learns theorems proving by the way of visualization and the use of ICT in teaching geometry can make the learning process more effective as well as enhance the student's capabilities in understanding basic concepts. Moreover, facilitation through ICT in constructive environment yields much better achievement than traditional method of learning geometry. ICT helps to make connection between their prior knowledge and new knowledge through visually. Therefore, from the policy level, the use of ICT should be promoted. So, that the mathematics education can further be improved.

Implication

According to the finding of the data of the present study in different sector can the apply ICT in the teaching and learning geometry in the academic curriculum ICT can be apply in the kindergarten level to University level and future investigation on this topic has presented in the following section.

Implication for the Policy Study Level

The policy is the main roadmap of curriculum design, which has affected by the politics, need of the society, international curriculum. The ministry of education and NCED should encourage to the teacher to apply the technology teacher must get regular supervision must be need in the classroom. Feedback and motivation for the active teacher also reward and punishment need to apply in teacher evaluation. The results of this study suggest that policy maker can encourage using ICT in geometry classroom.

Implication for Practice Level

ICT assist learning is the student center method in the learning process. Students can take active participation in learning process. So, school can use ICT while teaching. The present study has established ICT assisted instruction significantly improves the performance and learning achievement of the mathematics. The teacher can apply ICT as the bridge to connect the content and brain of student. ICT- assist learning can be arrange to present in large classrooms as it provides maximum amount of variety and flexibility by maintaining the quality as well quantity.

Implication for Further level

This study had conducted with small sample size. Large sample size for the further studies in implicated to increase the validity of the study. The study had conducted in grade nine. The further study can be conduct in the other lower class and upper class in the school level to make the standard of the thesis topics. Experimental verification of the content which student can solve themselves in lab is the area of the study.

Recommendations

This study focused on theorems proving of Triangle, Parallelogram and Circle lesson at grade nine, thus the results cannot be generalized to the other grade levels and other geometry lesson. Further research may be conducted at different grade level and different geometry topics. This research was limited with three weeks. Further research may be conducted to investigate long term effects of ICT usage on student's achievement in all geometry content area. The following topics has recommended as the further research:

- The comparison between the perception of teachers and students may also be conducted.
- The effectiveness of ICT in ruler area of Nepal can be conducted.
- The access of the technology in mathematics classroom of Nepal may also be conducted.

References

- Amina (2003). *Effectiveness of ICT in Mathematics at secondary Level*. Retrieved from <https://www.sciencedirect.com/science/article/pii/S18770428112007>.
- Cambridge & others (2002). *ICT and Mathematics: A Guide to Learning and Teaching Mathematics*. (11-19). Retrieved from www.adrianoldknow.org.uk/full%20report.doc.
- Dhakal, B.P. (2014). *ICT in Mathematics: Access and Quality in Higher Education*. *Mathematics Education Forum*, II (36), 11-15.
- Daniel, M. (2004). *Doing Quantitative Research in Education*. London : Sage Publication .
- Drijvers, P., Monaghan, J., Thomas, M., Touché, L. (2003). *Use of Technology in Secondary Mathematics*. Retrieved from www.ibo.org/globalassets/publication/ib-research.
- Eid, A. (2014). *A Study on the use of ICT in Teaching in Secondary Schools in Kuwait* (Doctoral dissertation, Cardiff Metropolitan University, Kuwait). Retrieved from <http://repository.Cardiffmet.ac.uk>.
- Fuglestad, A.B. (2003). *ICT and Mathematics Learning: Developing Communities for Learning with Technology*. Retrieved from www.prosjekt.uia.no/iktm/papers/ICT.
- Fuglestad, A. B. (2009). *ICT for Inquiry in Mathematics : A Developmental Research Approach*. *Journal of Computers in Mathematics and Science Teaching*. 28(2), 192-202.
- Hohenwarter, M., & Jones, K. (2007). *Ways of linking Geometry and Algebra: The Case of GeoGebra*. In D. Kuche *Research into Learning Mathematics*, 27(3), 126-131.
- Johnston, K., & Ng'ambi, D. (2006). *An ICT Mediated Constructivist Approach for Increasing Academic Support and Teaching Critical Thinking Skills*. *Educational Technology & Society*, 9(3), 244-253.

- Jones, K. (2002). *Issues in the Teaching and Learning of Geometry*. In: Linda Hagarty (Ed), *Aspects of Teaching Secondary Mathematics: Perspectives on Practice*. (pp. 121-139). RoutledgeFalmer, London.
- Jones, K. (2011). *The Value of Learning Geometry with ICT: Lessons from Innovative Education Research*. In Adrian Old know and Corol Knights (Eds), *Mathematics Education with Digital Technology* (PP.39-45). London: Continuum.
- Jones, K. (2033). *The Value of Learning Geometry with ICT: Lesson from Innovative Educational Research*. In Adrian Old known and Carol Knights (EDS), *Mathematics Education with Digital Technology*. London: Continuum. (Chapter 5, Pp. 3945) .
- Kofi, A. (2010). Relationship between students attitudes toward ICT and their achievement in ICT at the University of Cape Coast. *International Journal of Basic Education*, 1.
- Kristof D.W.& Nicky R. (2014). Does ICT Matter for effectiveness and efficiency in Mathematics education: Warmo-esberg 26,1000 Brussels (Belgium).
- Leong, K.E. (2013). Impact of Geometer's Sketchpad on Student Achievement in Graph Functions. *The Malaysian Online Journal of Educational Technology*, 1(2), 19-31.
- Mathomo, M. M. (2006). *The Use of Educational Technology in Mathematics Teaching and Learning: An Investigation of a South African Rural Secondary School*.
- National Curriculum Board, (2009). *Shape of the Australian Curriculum: Mathematics*. Attorney- Generals Department, Australia: Author.
- NCT, M. (2000). *Principles and Standards for School Mathematics*. Reston, VA: Author.
- Piaget, J. (1980). *Adaptation and Intelligence*. Chicago: University of Chicago Press.
- Rohani (2015). *The Effects of GeoGebra on Mathematics Achievement: Enlightening Coordinate Geometry Learning*. Retrieved from <https://www.sciencedirect.com/science/article/pii/S18770428112007>.

Shadaan, P. & Ed., L.K. (2013). Effectiveness of Using GeoGebra on Student's Understanding in Learning Circle, *The Malaysian Online Journal of Educational Technology*, 1(4).

Shrestha, R. (2012). *Status of ICT Use in Teaching/Learning Mathematics*. An Unpublished Master Thesis.

The Mathematics Association, (2002). *ICT and Mathematics: A Guide to Learning and Teaching Mathematics*. Retrieved from <http://eprints.soton.ac.uk>.

APPENDIX-A**Mathematics Achievement Pretest****Sub:** -Compulsory Mathematics**Full Mark:**-30**Class:** -IX**Pass Mark:** -10**Time:** -40 min**Attempt all the question:-****Group:A [8×1 =8]**

1. In the given figure, AB and CD both are perpendicular to PQ full stop point is AB//CD?

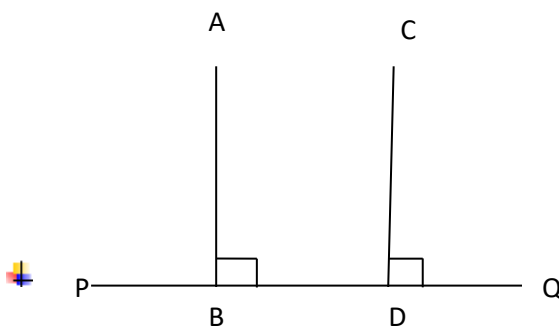

2. Write the name of obtuse angle of the following figure.

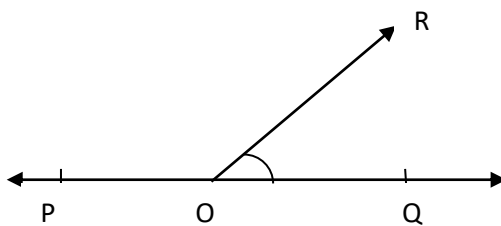

3. In the given figure, find the values of x .

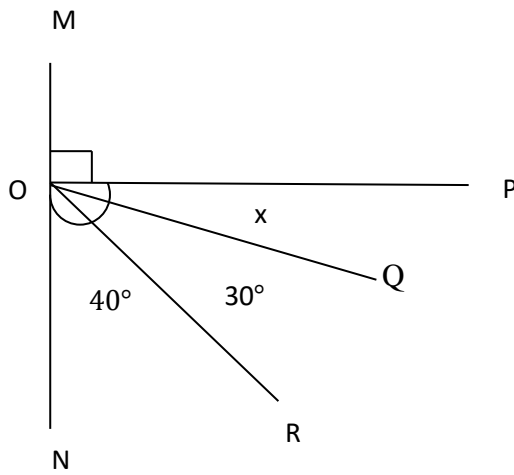

4. Find the value of 'a' in the given figure.

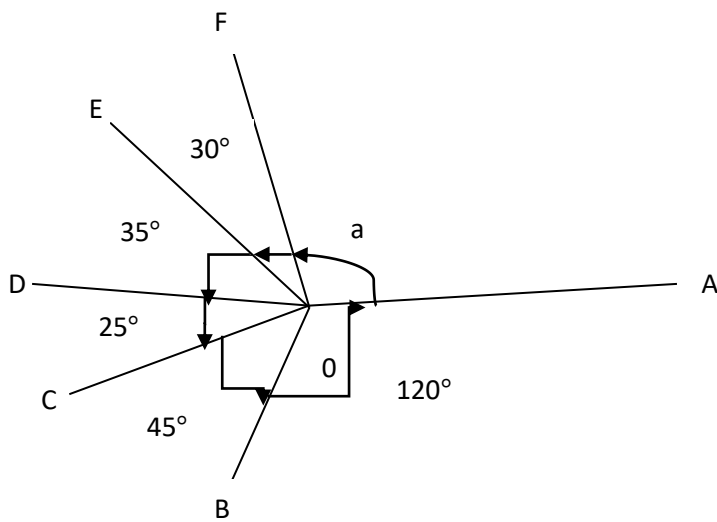

5. Find the value of x .

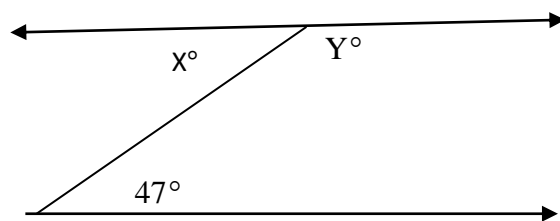

6. In the figure, two straight lines are intersected by a transversal. List the pair of External angles.

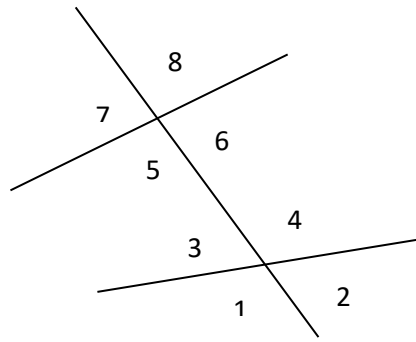

7. Find the value of x .

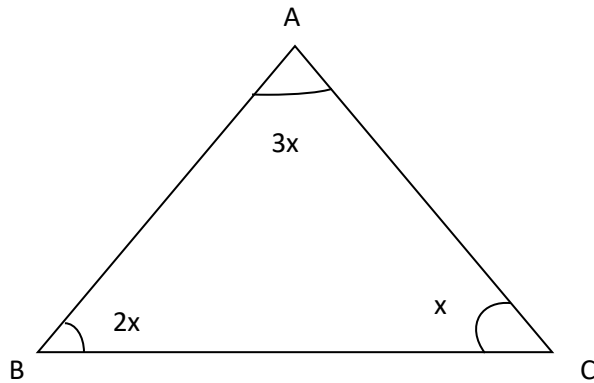

8) On the basis of the information given in the figure, find the value of X .

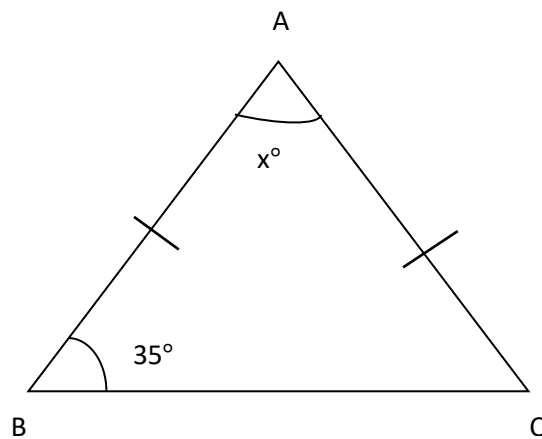

Group "B" [5×2=10]

9. Construct the angle of 45° with the help of compass.

10. Find the value of x, y, z and a in the given figure

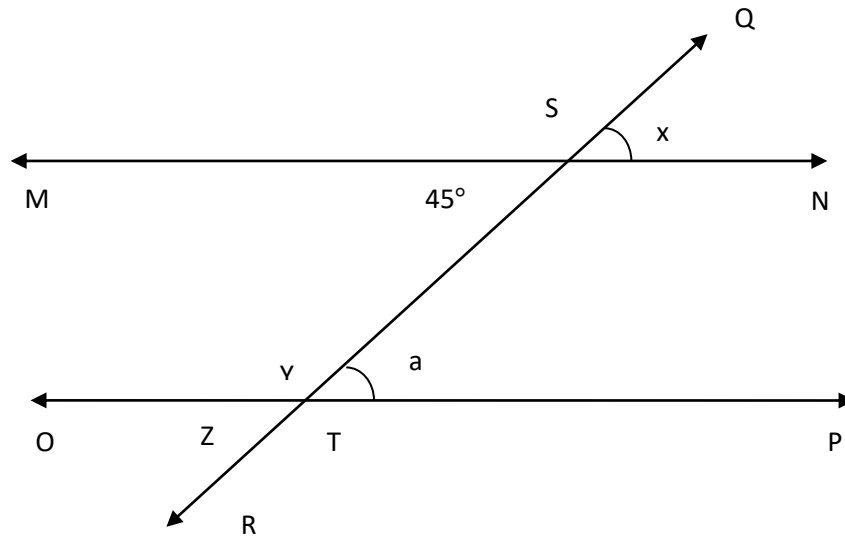

11. Find the value of x from the given figure.

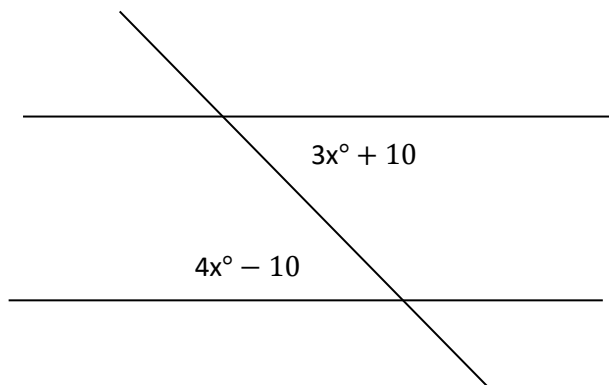

12. In the $\triangle ABC$, if $\angle BAC=90^\circ$, $AB=9\text{cm}$ and $AC=40\text{cm}$ find the length of BC .

13. In the given figure, ABCD is a rectangle .If $AC=20$ cm and $AB=16$ cm, Find the length of BD and AD

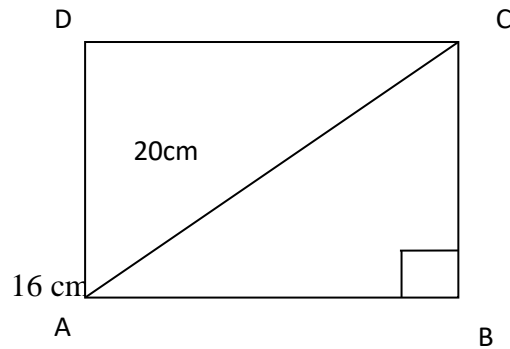

Group C [3×4=12]

14. Find the value of x, y and z in the following figures.

i)

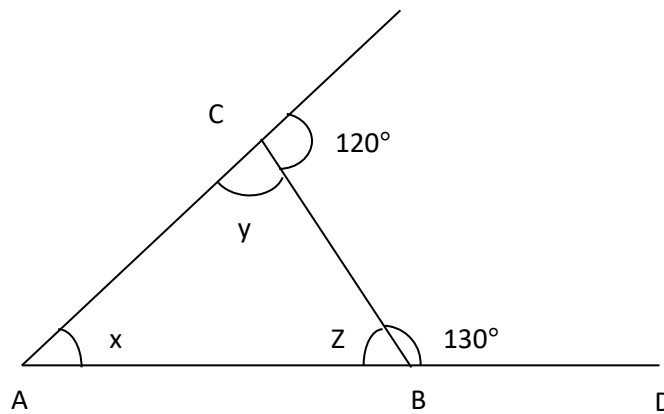

ii)

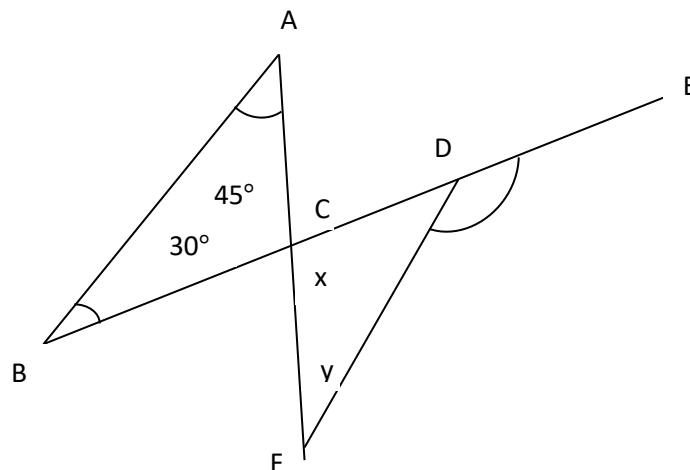

15. Prove that the base angles of an isosceles triangle are equal.

16. If $AB=AC=25$ cm and $BC=14$ cm, If $AD \perp BC$, find the length of AD .

Best of Luck

Appendix-B**Mathematics Achievement Post-Test****Class: - C. Math****Full Mark :- 30****Time: - 40 minute****Pass Mark: - 10****Attempt all the question:-****Group: A [8×1=8]**

1. How many perpendicular line can be draw on the line QR from point P.

. P

Q _____ R

2. Write the name of acute angle of the following figure.

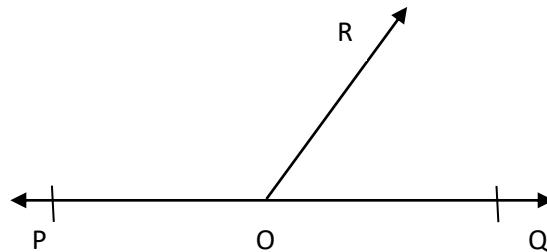

3. In the given figure find the value of a.

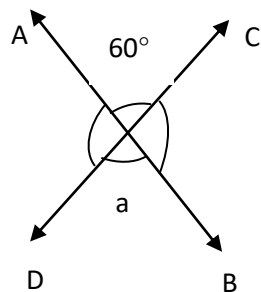

4. Find the value of 'x' in the given figure.

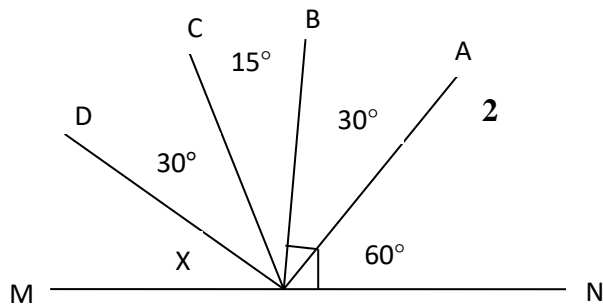

5. Find the value of x.

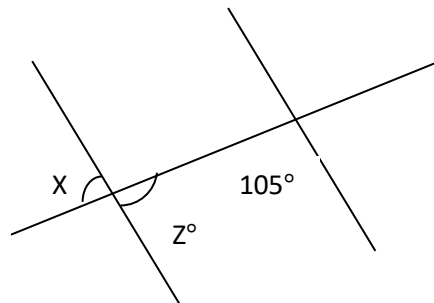

6. In the figure two straight lines are intersected by a transversal. List the pair internal Angles.

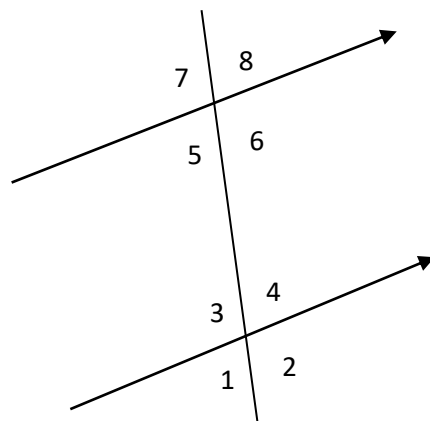

7. Find the value of y .

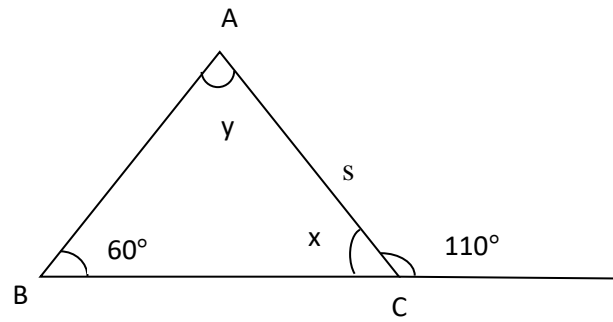

Group "B" [5×2 =10]

8) On the basis of the information given in the figure, find the value of X.

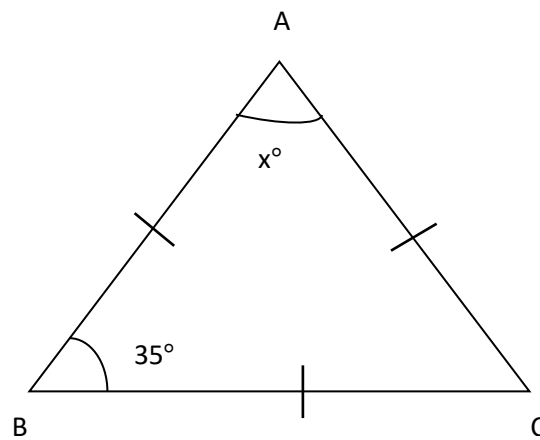

9) Construct the angle of 60° with the help of compass.

10) Find the value of x, y and z from the given figure.

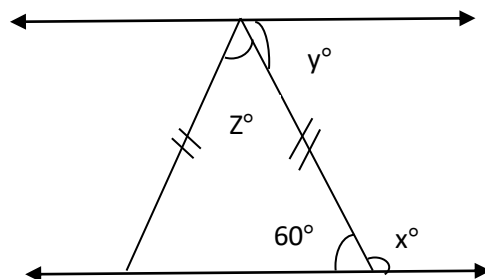

11. Find the value of the angles a° , x° , y° and z° .

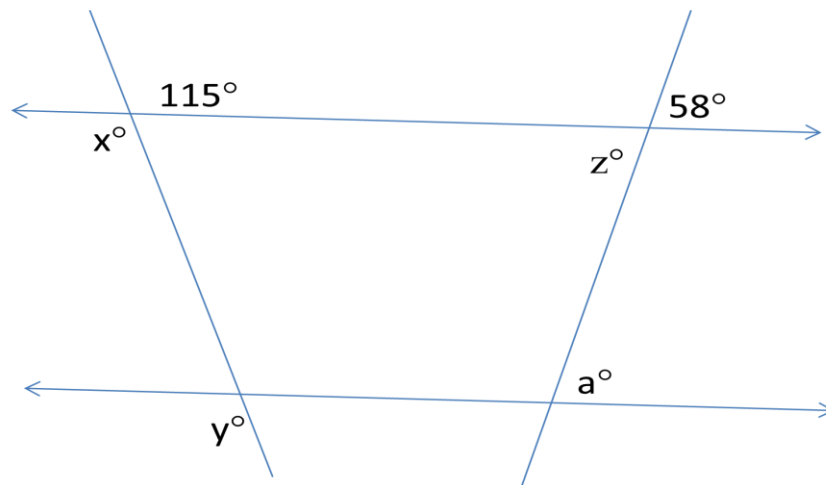

12. In the $\triangle ABC$, if $\angle BAC = 90^\circ$, $AB = 5\text{cm}$ and $AC = 13\text{cm}$. Find the length of BC .

13. In the given figure, $ABCD$ is a rectangle. If $AC = 25\text{ cm}$ and $AB = 20\text{cm}$ Find the length of BD & AD .

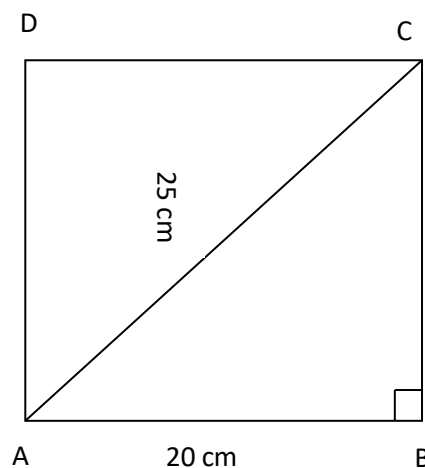

Group C [3×4=12]

14. Prove that the sum of internal angles of a triangle is equal to 180°

15. Prove that the opposite sides and angles of a parallelogram are equal.

16. Prove that a perpendicular draw from the centre of a circle to a chord bisects the Chord.

Appendix-C

Student Perception Scale

Dear Students,

Read each items carefully and tick (√) on your choice among the given option.

Name:

S.N.	Items	Strongly Agree	Agree	Neutral	Disagree	Strongly Disagree
1.	I was excited while using ICT in learning geometry.					
2.	I learnt a lot of geometry concept using ICT software.					
3.	Lesson with ICT software is interesting to learn geometry.					
4.	I felt confident to solve the problems using ICT.					
5.	The lessons with the ICT software help me to easily understand the theoretical part of geometric lesson triangle, Parallelogram and Circle.					

6. I benefited a lot through the teacher student's interaction.
7. I was able to visualize and answer the questions after each activity.
8. ICT software can help can help increase my achievement in geometry
9. I can think creatively and critically when using ICT.
10. I enjoyed learning mathematics much more by using ICT.
11. ICT encourage me participate in class activity.
12. I need more time to learn theoretical part of geometric lesson by using ICT.
13. It makes geometry class boring

14. ICT enables me to
get the idea of
proof easier.
15. I was able to find the
better connections
between previous
learning and new
learning
16. Overall I was satisfied
with the use of ICT
in learning geometry
17. I would like to learning
more geometric
concepts using ICT.

APPENDIX-D

Teaching Episodes

Teaching Episode-1

Chapter:Triangle

Section: Theorem Proving

Time: 45 min

Objective

At the end of the lesson the students should be able to :

- Prove the theorem the sum of internal angles of a triangle is equal to 180° by theoretically.

Prerequisites: Students are familiar with concept of triangle and knowledge of classification of triangle on the basis of sides and angle.

Activities

1. At first, researcher will present the content of today through power point, and then first few minutes of lesson hour, the content of lesson will introduce to the students such as: what is mean by triangle? How many types of triangle on the basis of sides? How many types of triangle on the basis of angle? After introduction of the topic, brief explanation about the content is made by the researcher and students to ask questions related to present content. Also students will engage to draw the triangle as well as Given, To prove and construction on their copy according to the present content. The researcher will utilize the projector and software when need.
2. In second, researcher use Geogebra software and demonstrate related steps by the way of visualization. After that, researcher and students will interact each other about figure as well as statement of the problem in which researcher give first priority to students. For answer so, the teacher role is as a facilitator for the whole learning process. After a brief explanation by the dynamic activity and discussion, the students will engage to give geometrical explanation pre designed visualize steps and write consequent steps on their copy. Then after complete proof, researcher will ask the questions to students related to the theorem. In this phase

students will actively participate in the learning process in that they are imagining, communication, exploring and expressing their own ideas, while the students are dealing with the activities, the researcher gives feedback to the students' errors and guides them about their questions.

3. In the last but not least phase, the researcher constructs, drags and resizes the object which is displayed on the screen dynamically. They observe the results of the movements. In such a learning environment, students create their own understanding related steps of a theorem proof and these phases are revisited if necessary. At the end of the lesson, the researchers summarize the main points and definitions, also give the home assignment as well as students will tell the next content.

The formal construction is generated using GeoGebra, and corresponding steps are visualized such as:

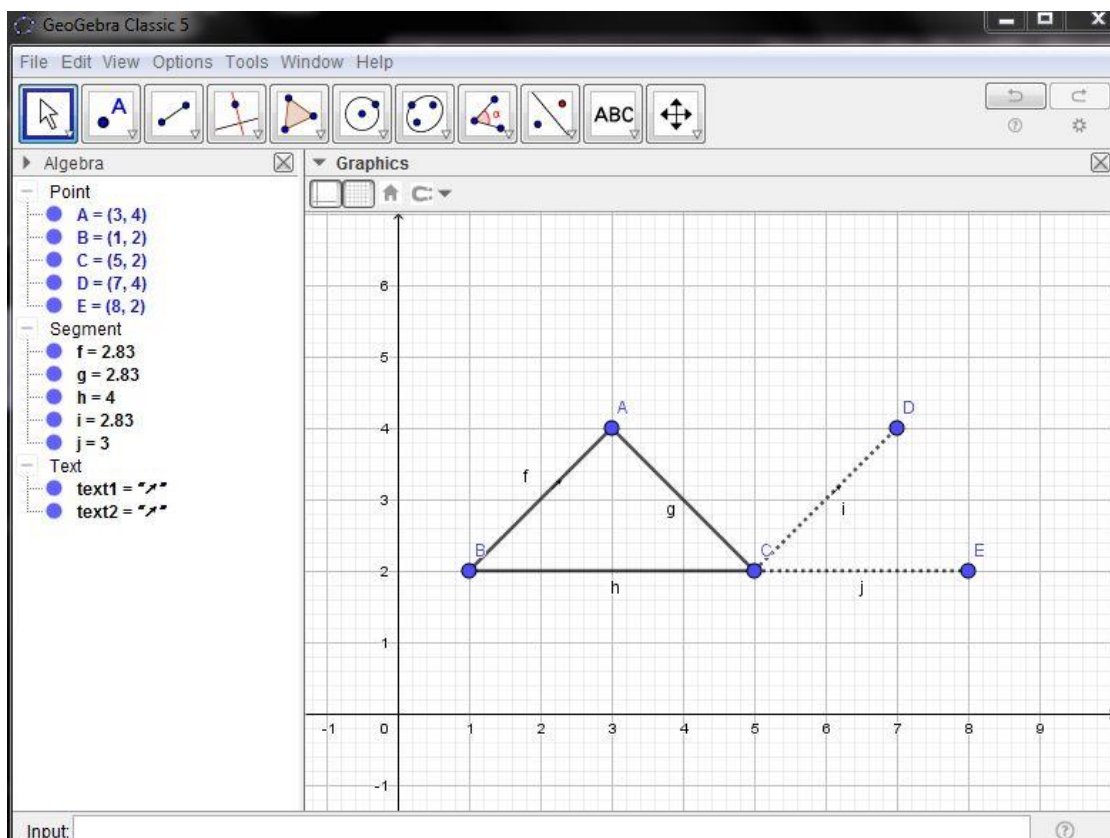

Remark: Last researcher demonstrate 'Given', 'To prove', 'Construction' (if necessary), 'Statement' and 'Reason' in power point if the students feel awkward.

Teaching Episode-2

Chapter: Triangle

Section: Theorem proving

Time: 45 min

Objective

At the end of the lesson students should be able to :

- Prove the theorem the exterior angle of a triangle is equal to the sum of two opposite interior angles by theoretically.

Prerequisites: Students are familiar with concepts of triangle, knowledge of classification of triangle on the basis of sides and angle.

Activities

1. In first, researcher will present the content of today through power point. then first few minute, reviewing the prerequisite knowledge of the students. Then content of lesson will introduce to the students and a question related to the topic is clarify. Researcher will tell students the aim of the activity and what they are suppose to do in the activity. Also students will engage to draw the diagram as well as to write given, to prove and construction(if necessary) on their copy. Moreover, enable students to make conjectures, formulate concepts and proof idea by themselves. The researcher will utilize the projector and software when need.
2. In second, researcher use GeoGebra software and demonstrate related steps by the way of visualization. Researcher will start discussion with students about present figure. After a brief discussion by the dynamic activity, the students are engage to write consequent steps present bb GeoGebra software on their copy. Then after complete proof, researcher will ask the questions o students related to he theorem. In this phase, the researcher will motivate students to active participates in the learning. Process in that they are imagining, communicating, exploring and expressing their ideas, while the students are dealing with the activities the researcher will give feedback on the students crops and guide them about their questions.

- In last but not least phase, researcher construct, drag and resize the object which is display on the screen dynamically. They observe the result of the movements. In such learning environment students create their own understanding related steps of theorem prove and these phases will revise if necessary. These students generatenew question. Finally, the researcher summarizes the main points and definition also gives the home assignment as well as students will tell the next content.

The formal construction will generate using GeoGebra, and corresponding steps will visualized such as:

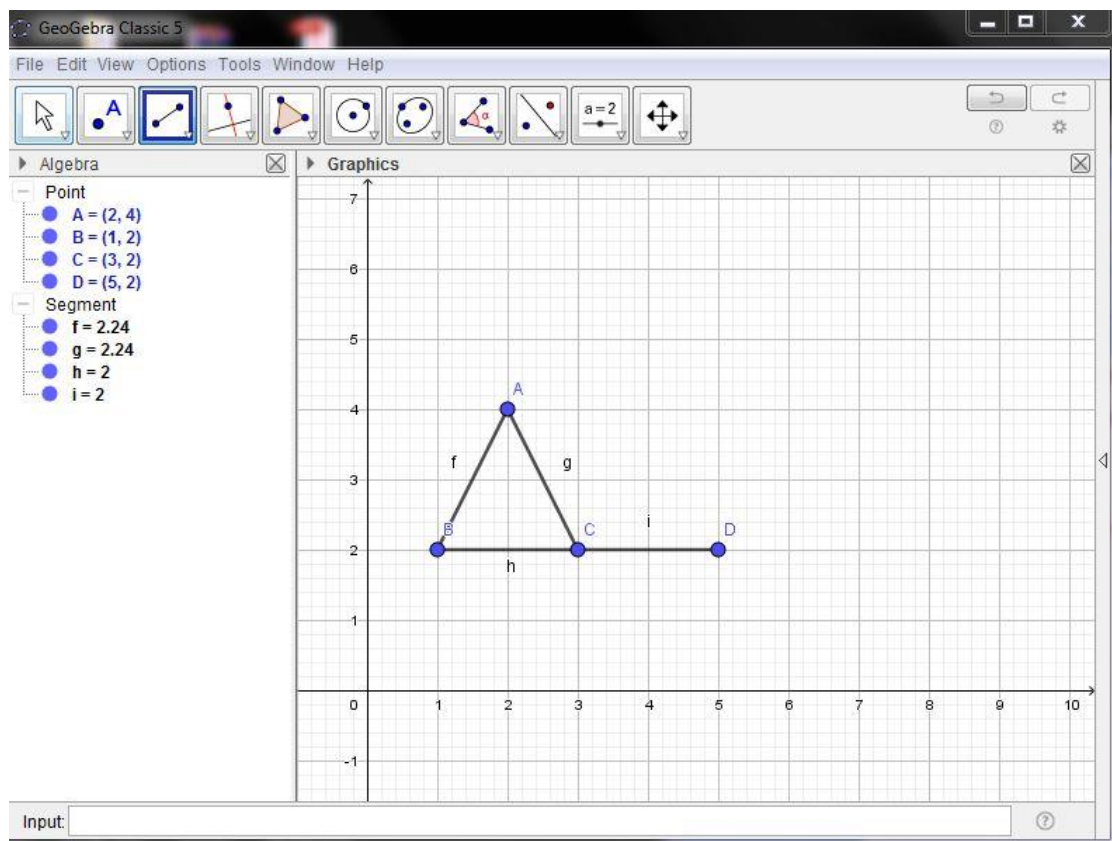

Remark: Last researcher demonstrate 'Given' to prove' construction, statements and Reasons in power point if the student fell awkward.

Teaching Episode-3**Chapter:** Triangle**Section:** Theorem proving**Time:** 45 min**Objective**

At the end of the lesson students should be able to:

- Prove the bisector of the vertical angle of an isosceles triangle bisects the opposite side perpendicularly.

Prerequisites: Students are familiar with concept of triangle and knowledge of classification of triangle on the basis of sides and angle and also knowledge of S.A.S., A.S.A., S.S.S. condition.

Activities

1. In first phase, researcher will present the content of today through power point, and related figure will demonstrate by GeoGebra software. Then discuss with the students about present figure and statement of theorem by asking question. In addition, students questions related to the topic are clear. Also students are engage to draw the diagram as well as write Given, To prove and construction on their copy. Then researcher will discuss with student for developing the proof ideas and how to write geometric proof and researcher will be use the projector and software when need.
2. In second phase, researcher use GeoGebra software and demonstrate related steps of theorem about present figure. After a brief discussion by the dynamic activity, Students will engage to write consequent steps of proof in their own words on their copy. At this time researcher act as a facilitator to encourage students for activity participate for the whole learning process. Then after complete proof, researcher will ask the questions to students related to the theorem. In his phase, the researcher will motivate students to active participates in the learning process. While the students are dealing with the activities. Theresearcher give feedback to the students errors and guide them about their questions.

- In last but not least phase, researcher construct, dragged and resize the object which will display on the screen dynamically. They observe the results of the movement. In such learning environment students create their own understanding related steps of theorem proof and these phases will revise. Finally, the researcher summarized the main points and definition also given the home assignment as well as students will tell he next content.

The formal construction will generate using GeoGebra, and corresponding steps will visualize such as:

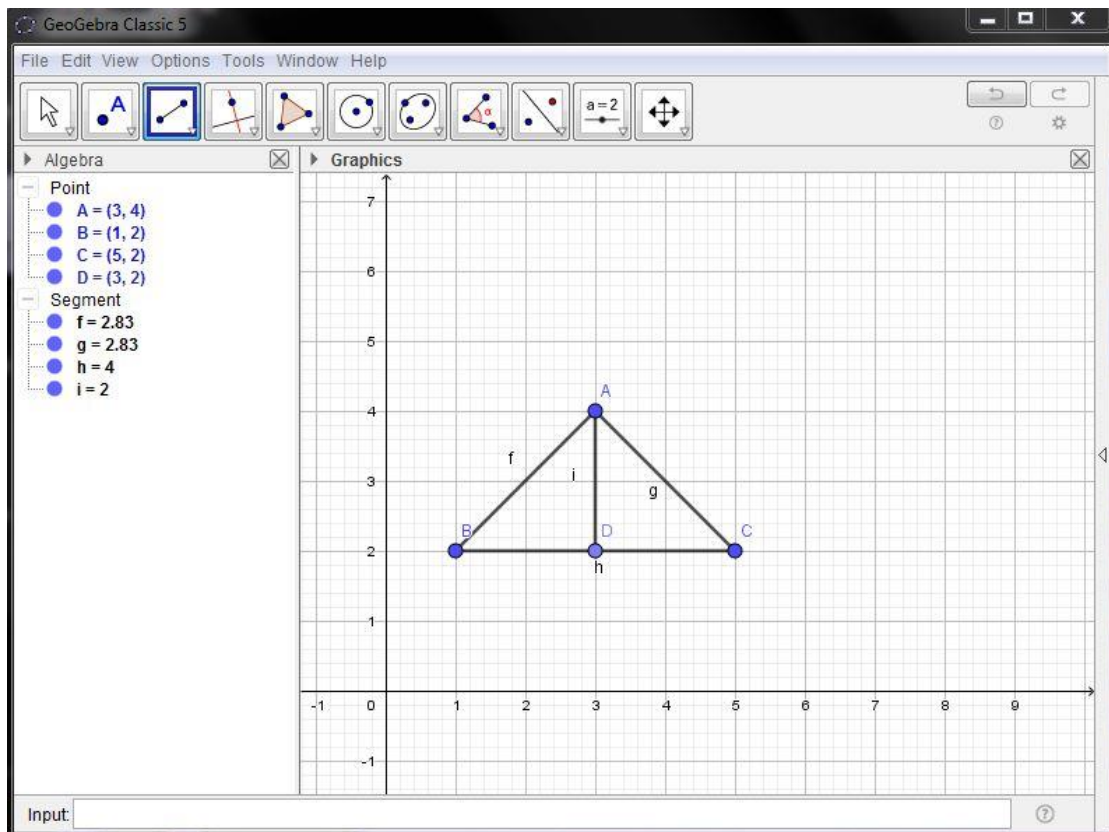

Remark: Last researcher demonstrate given, 'to prove', 'construction 'statement' and reasons' in power point if he students fell awkward.

Teaching Episode-4**Chapter:** Parallelogram**Section:** Theorem Proving**Time:** 45 min**Objective**

At the end of the lesson the students should be able to:

Prove the theorem that the opposite sides and angles of a parallelogram are equal by theoretically.

Prerequisites: Students are familiar with concepts of parallelogram, conditions of any two straight lines are parallel, and conditions of any two triangles are congruent.

Activities:

1. In first, researcher will present the content of today through power point and visualize related figure. Then first few minutes of lesson hour, review the prerequisite knowledge of the students. Then content will introduce to the students and researcher will ask question related to the present topic such as: what is given, what is to prove and how prove. Also Students will engage to draw diagram as well as write given, to prove and construction on their copy. Then researcher will discuss with students for developing the proof strategy and researcher will use the projector and software when need.
2. In second phase, researcher use GeoGebra software and demonstrate related steps of theorem proof by the way of visualization to enable the students for their work. At this time researcher will start discussion by the dynamic activity. Then students engage to write consequent steps own their word on their copy. The researcher will act as a facilitator to encourage students for actively participates. Then after complete proof, researcher will ask the questions to students related to theorem. In this phase, researcher will motivate students to active participation in learning in that they are imagining, communicating, exploring and expressing their ideas, while the students are dealing with activities, the researcher give feedback on the students errors and guide them about their questions.

- In last but not least phase researcher construct, dragged and resize the object which will display on the screen dynamically. They observe the result of the movements. In such learning environment students create their own understanding related steps of theorem proof and these phases will revise if necessary. Finally, researcher summarizes the main points and definition also gives the home assignment as well as students will tell the next content.

The formal construction will generate using GeoGebra, and corresponding steps will visualize such as:

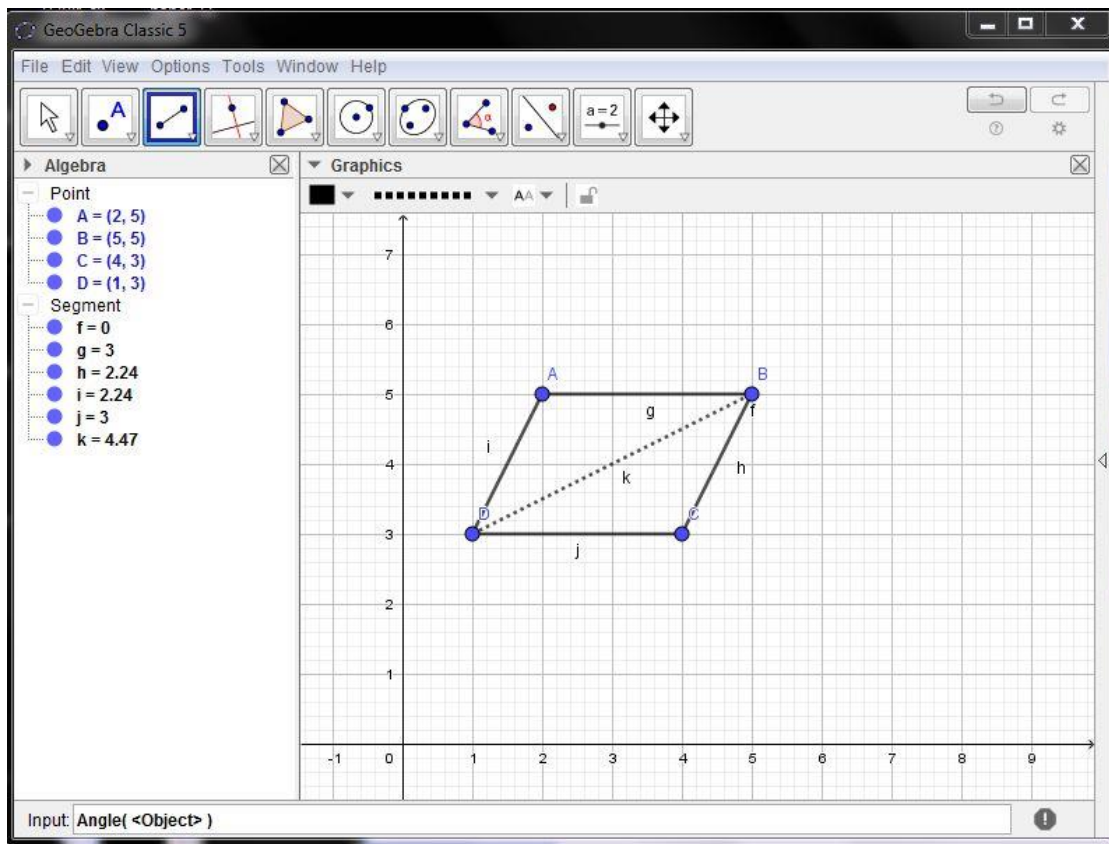

Remark: At Last researcher demonstrate 'given', to prove: 'construction (if necessary) statements' and reasons' in power point if the students fell awkward.

Teaching Episode-5

Chapter:Parallelogram

Section:Theorem proving

Time:45 min

Objective

At the end of the lesson the students should be able to:

- A quadrilateral whose opposite sides are equal is a parallelogram by theoretically.

Prerequisites: - Students are familiar with concepts of parallelogram, conditions of any two straight lines are parallel, and conditions of any two triangles are congruent.

Activities:

1. In first, researcher will present the content of today through power point and visualize related figure. Then first few minutes of lesson hour, review the prerequisite knowledge of the students. Then content with introduce to the students and researcher will ask question related to the present topic such as: what is given, what is to prove and how prove. Also students will engage to draw diagram as well as write given, to prove and construction on their copy. Then researcher will discuss with students for developing the proof strategy and researcher will use the projector and software when need.
2. In second phase, researcher use GeoGebra software and demonstrate related steps of theorem proof by the way of visualization to enable the students for their work. At this time researcher will start brief discussion by the dynamic activity. Then students engage to write consequent steps own their word on their copy. The researcher will act as a facilitator to encourage students for actively participates. Then after complete proof, researcher will ask the questions to students related to theorem. In this phase, researcher will motivate students to active participation in learning in that they are imagining, communicating, exploring and expressing their ideas, while the students are dealing with activities, the researcher give feedback on the students errors and guide them about their questions.

3. In last but not least phase, researcher construct, dragged and resize the object which will display on the screen dynamically. They observe the result of the movements. In such learning environment students create their own understanding related steps of theorem proof and this phase will revise if necessary. Finally, researcher summarizes the main points and definition also gives the home assignment as well as students will tell the next content.

The formal construction will generate using GeoGebra, and corresponding steps will visualize such as:

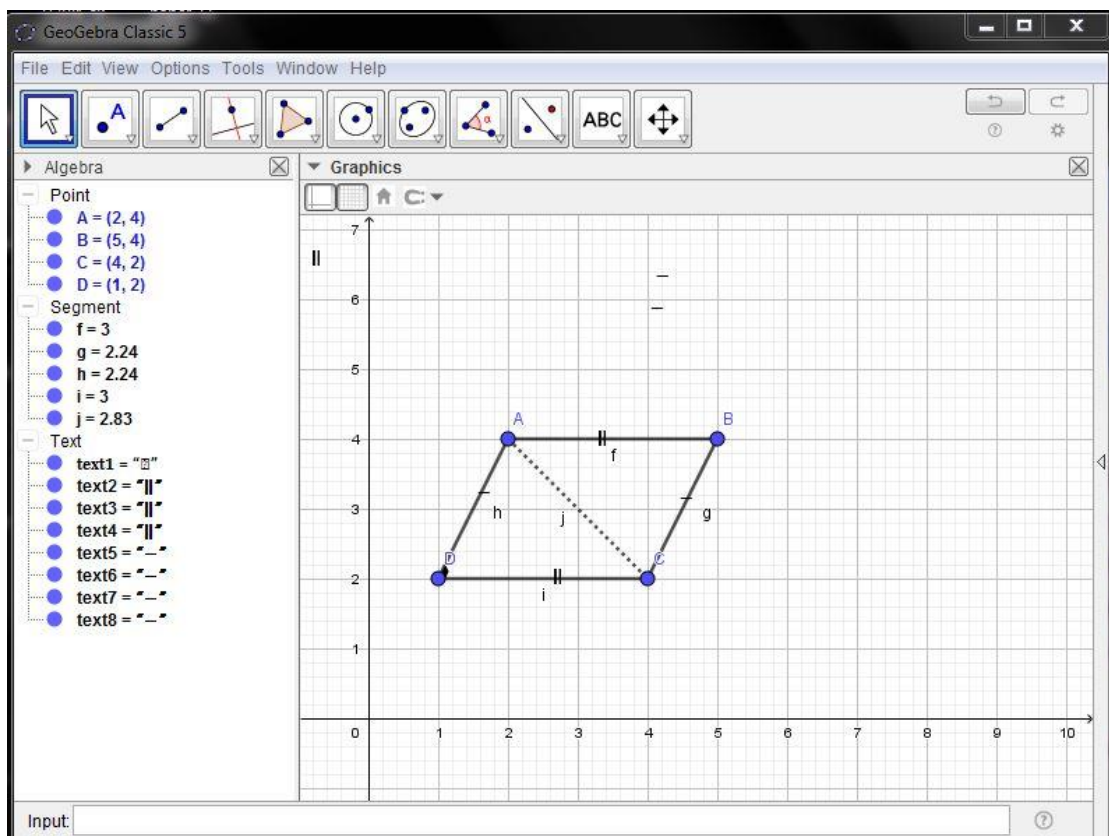

Remark: At Last researcher demonstrate 'given', to prove: 'construction (if necessary) statements' and reasons' in power point if the students fell awkward.

Teaching Episode-6**Chapter:** Parallelogram**Section:** Theorem Proving**Time:** 45 min**Objective**

At the end of the lesson students should be able to:

- Prove the theorem two line segments joining the opposite end points of two equal and parallel line segments are bisected by each other i.e. bisect each other by theoretically.

Prerequisites: -Students are familiar with concepts of parallelogram, conditions of any two straight lines are parallel, and conditions of any two triangles are congruent.

Activities:

1. In first, researcher will present the content of today through power point and visualize related figure. Then first few minutes of lesson hour, review the prerequisite knowledge of the students. Then content will introduce to the students and researcher will ask question related to the present topic such as: what is given, what is to prove and how prove. Also students will engage to draw diagram as well as write given, to prove and construction on their copy. Then researcher will discuss with students for developing the proof strategy and researcher will use the projector and software when need.
2. In second phase, researcher use Geogebra software and demonstrate related steps of theorem proof by the way of visualization to enable the students for their work. At this time researcher will start brief discussion by the dynamic activity. Then students engage to write consequent steps own their word on their copy. The researcher will act as a facilitator to encourage students for actively participates. Then after complete proof, researcher will ask the questions to students related to theorem. In this phase, researcher will motivate students to active participation in learning in that they are imagining, communicating, exploring and expressing their ideas, while the students are dealing with activities, the researcher give feedback on the students errors and guide them about their questions.

- In last but not least phase, researcher construct, dragged and resize the object which will display on the screen dynamically. They observe the result of the movements. In such learning environment students create their own understanding related steps of theorem proof and these phases will revise if necessary. Finally, researcher summarizes the main points and definition also gives the home assignment as well as students will tell the next content.

The formal construction will generate using Gebro, and corresponding steps will visualize such as:

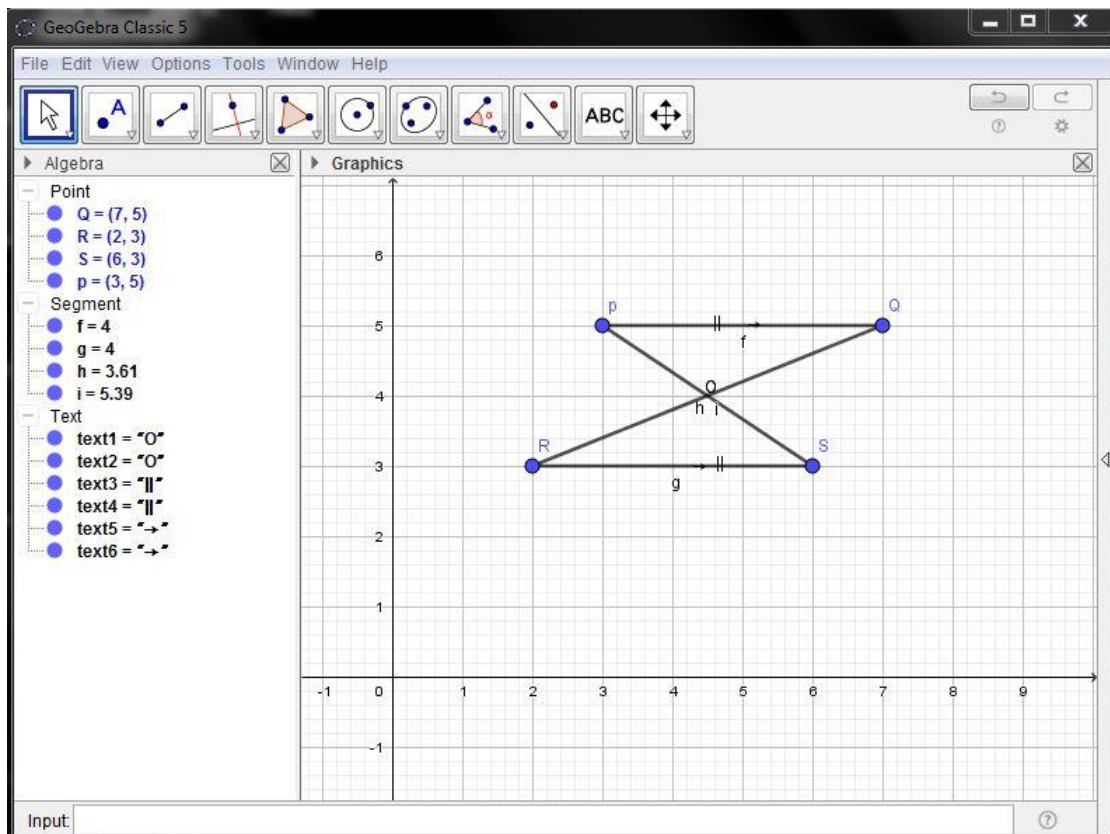

Remark: Atlast researcher demonstrate 'given', to prove: 'construction (if necessary) statements' and reasons' in power point if the students fell awkward.

Teaching Episode-7

Chapter: Circle

Section: Theorem proving

Objective

At the end of the lesson students should be able to:

- Prove the theorem a perpendicular drawn from the centre of a circle to a chord bisects the chord.

Prerequisites: Students are familiar with concept of circle; conditions of any two triangles are congruent.

Activities:-

1. In first, researcher will present the content of today through power point and visualize related figure. Then first few minutes of lesson hour, review the prerequisite knowledge of the students. Then content with introduce to the students and researcher will ask question related to the present topic such as: what is given, what is to prove and how prove. Also Students will engage to draw diagram as well as write given, to prove and construction on their copy. Then researcher will discuss with students for developing the proof strategy and researcher will use the projector and software when need.
2. In second phase, researcher use GeoGebra software and demonstrate related steps of theorem proof by the way of visualization to enable the students for their work. At this time researcher will start brief discussion by the dynamic activity. Then students engage to write consequent steps own their word on their copy. The researcher will act as a facilitator to encourage students for actively participates. Then after complete proof, researcher will ask the questions to students related to theorem. In this phase, researcher will motivate students to active participation in learning in that they are imagining, communicating, exploring and expressing their ideas, while the students are dealing with activities, the researcher give feedback on the students errors and guide them about their questions.
3. In last but not least phase researcher construct, dragged and resize the object which will display on the screen dynamically. They observe the result of the

Teaching Episode-8

Chapter:Circle

Section:Theorem Proving

Objective:

At the end of the lesson students should be able to :

- Prove the theorem the perpendicular bisector of a chord of a circle passes through the centre of that circle by theoretically.

Prerequisites: -Students are familiar with concept of circle; conditions of any two triangles are congruent.

Activities:-

1. In first, researcher will present the content of today through power point and visualize related figure. Then first few minutes of lesson hour, review the prerequisite knowledge of the students. Then content will introduce to the students and researcher will ask question related to the present topic such as: what is given, what is to prove and how prove. Also students will engage to draw diagram as well as write given, to prove and construction on their copy. Then researcher will discuss with students for developing the proof strategy and researcher will use the projector and software when need.
2. In second phase, researcher use GeoGebra software and demonstrate related steps of theorem proof by the way of visualization to enable the students for their work. At this time researcher will start brief discussion by the dynamic activity. Then students engage to write consequent steps own their word on their copy. The researcher will act as a facilitator to encourage students for actively participates. Then after complete proof, researcher will ask the questions to students related to theorem. In this phase, researcher will motivate students to active participation in learning in that they are imagining, communicating, exploring and expressing their ideas, while the students are dealing with activities, the researcher give feedback on the students errors and guide them about their questions.
3. In last but not least phase, researcher construct, dragged and resize the object which will display on the screen dynamically. They observe the result of the

movements. In such learning environment students create their own understanding related steps of theorem proof and these phases will revise if necessary. Finally, researcher summarizes the main points and definition also gives the home assignment as well as students will tell the next content.

The formal construction will generate using GeoGebra, and corresponding steps will visualize such as:

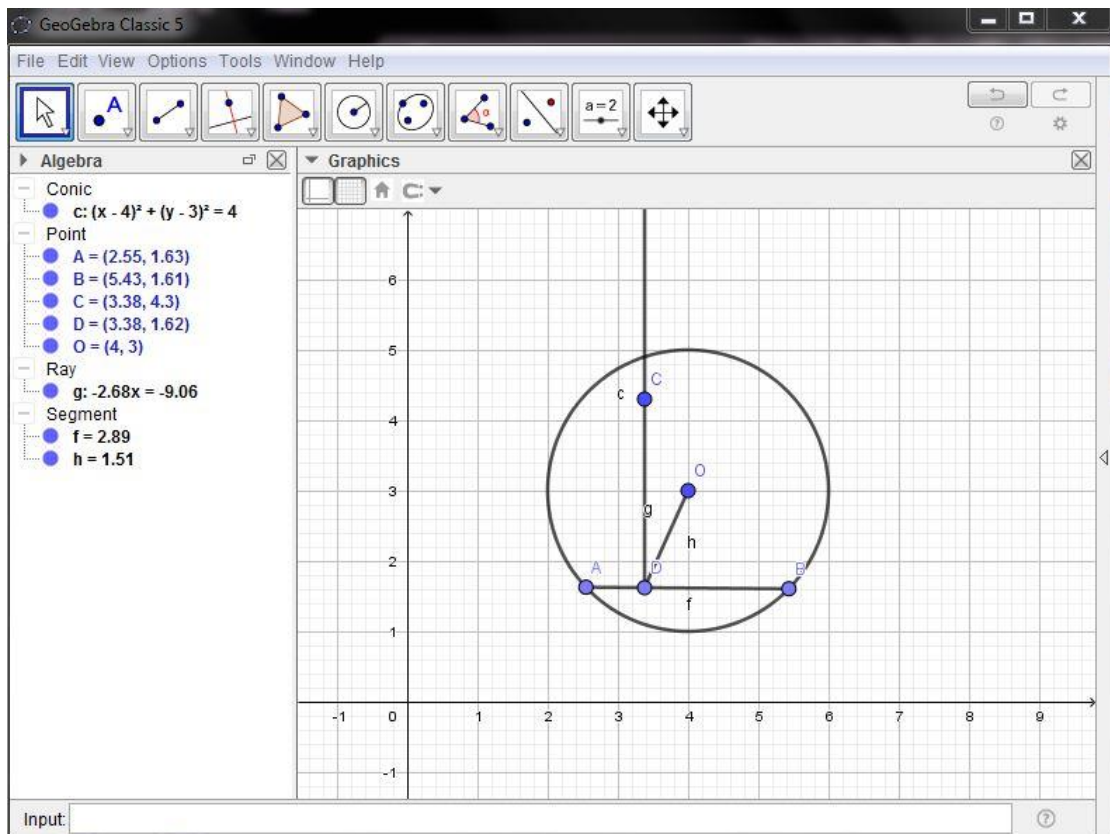

Remark: Atlast researcher demonstrate 'given', to prove: 'construction (if necessary) statements' and reasons' in power point if the students fell awkward.

Teaching Episode-9

Chapter: Circle

Section: Exercise

Time: 45 min

Objective

At the end of the lesson students should be able to:

- Solve the problem related to the above theorems

Prerequisites: Students are familiar with basic concepts about circle as well as have the knowledge of previously proved theorem

Activities:-

1. In first phase, researcher was presented the content of today through power point. Then first few minute, reviewing the prerequisite knowledge of the students. After that, researcher was asks question related to the present content. Also students were engaged to draw the presented diagram on their copy. Then researcher was start discussion with students for finding the value of x and y from the given figure.
2. In second phase, formal construction of given figure was constructed by the way of GeoGebra such as:

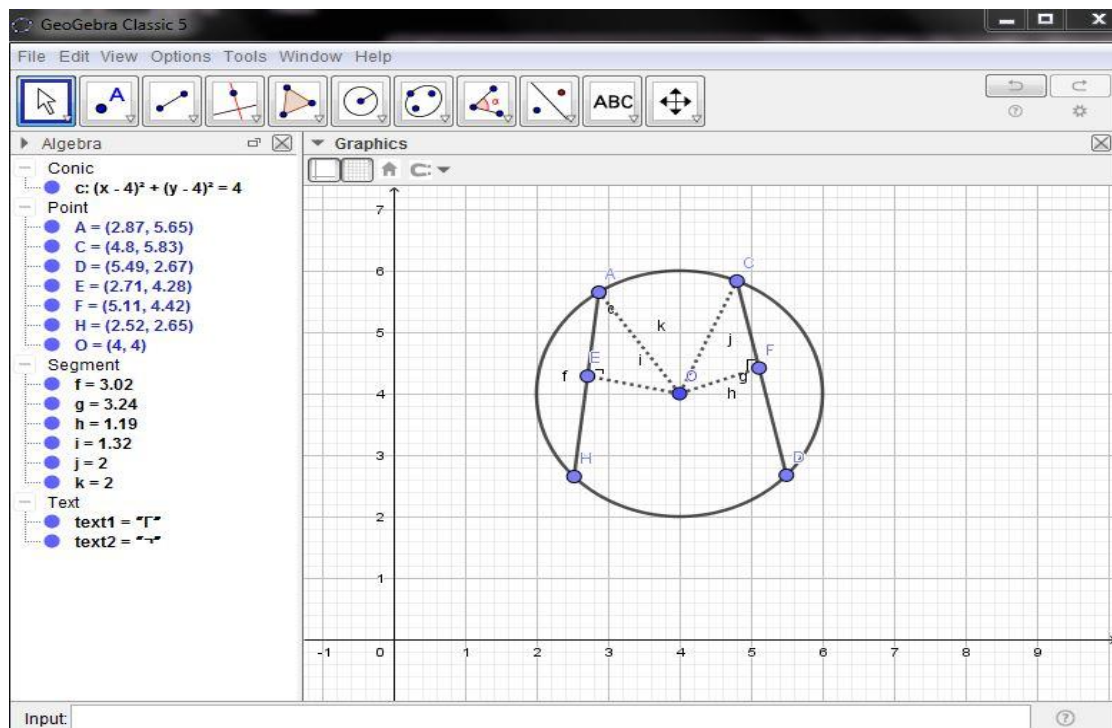

After that, researcher was start discussion with the students about figure and students are involved in the interaction to find the value of x and y. At his time

researcher acted as a facilitator to encourage students for actively participate. Then, researcher measures the unknown angle by GeoGebra software and asks reason to the students behind these unknown angles and researcher gave feedback on the students' errors and guided them about their questions.

3. After measuring angle in GeoGebra, researcher demonstrates the all solving process by slides in Power point. Moreover, researcher gives such type of problem to the students by making the figure in GeoGebra window. Also researcher dragged and resized the constructed figure which was displayed on the screen dynamically. Students observed the results of the movements and created their own understanding of solving geometrical problem. Finally, researcher summarized the main points as well as gives home assignment.

TEACHING EPISODE FOR CONTROL GROUP**APPENDIX-E****Teaching Episode-1**

Chapter: Triangle

Section: Theorem Proving

Time: 45 min

Objective

At the end of the lesson the students should be able to :

- Prove the theorem the sum of internal angles of a triangle is equal to 180° by theoretically.

Prerequisites: Students are familiar with concept of triangle and knowledge of classification of triangle on the basis of sides and angle.

Activities

1. At first, researcher will present the content of today, and then first few minutes of lesson hour, the content of lesson will introduce to the students such as : what is mean by triangle ? How many types of triangle on the basis of sides? How many types of triangle on the basis of angle? After introduction of the topic, brief explanation about the content is made by the researcher and students to ask questions related to present content. Also students will engage to draw the triangle as well as given, to prove and construction on their copy according to the present content.
2. In second, researcher demonstrates related steps by the way of writing on the board. After that, researcher and students will interact each other about figure as well as statement of the problem in which researcher give first priority to students. For answer so, the teacher role is as a facilitator for the whole learning process. After a brief explanation by the dynamic activity and discussion, the students will engage to give geometrical explanation pre designed steps and write consequent steps on their copy. Then after complete proof, researcher will ask the questions to students related to the theorem. In this phase students will active participates in the learning process in that they are imagining, communication,

exploring and expressing their own ideas, while the students are dealing with the activities, the researcher give feedback to the students error and guide them about their questions.

- 3.** In last but not least phase, researcher constructs the object. They observe the results of the objects. In such learning environment students create their own understanding related steps if theorem proof and these phases are revisit of necessary. At the end of the lesson the researchers summarize the main points and definition also gives the home assignment as well as students will tell the next content.

Teaching Episode-2

Chapter: Triangle

Section: Theorem proving

Time: 45 min

Objective

At the end of the lesson students should be able to :

- Prove the theorem the exterior angle of a triangle is equal to the sum of two opposite interior angles by theoretically.

Prerequisites: Students are familiar with concepts of triangle, knowledge of classification of triangle on the basis of sides and angle.

Activities

1. In first, researcher will present the content of today. Then first few minute, reviewing the prerequisite knowledge of the students. Then content of lesson will introduce to the students and a question related to the topic is clarify. Researcher will tell students the aim of the activity and what they are suppose to do in the activity. Also students will engage to draw the diagram as well as to write given, to prove and construction (if necessary) on their copy. Moreover, enable students to make conjectures, formulate concepts and proof idea by themselves.
2. In second, researcher demonstrates related steps by the way of writing on the board. Researcher will start discussion with students about present figure. After a brief discussion by the dynamic activity, the students are engage to write consequent steps present on their copy. Then after complete proof, researcher will ask the questions o students related to he theorem. In this phase, the researcher will motivate students to active participates in the learning. Process in that they are imagining, communicating, exploring and expressing their ideas, while the students are dealing with the activities the researcher will give feedback on the students crops and guide them about the questions.
3. In last but least phase, researcher constructs the object. In such learning environment students create their own understanding related steps of theorem prove and these phases will revise if necessary. These students generate new question. Finally, the researcher summarizes the main points and definition also gives the home assignment as well as students will tell the next content.

Teaching Episode-3

Chapter: Triangle

Section: Theorem proving

Time: 45 min

Objective

At the end of the lesson students should be able to:

- Prove the theorem in an isosceles triangle, the perpendicular bisector of the base bisects the vertical angle

Prerequisites: Students are familiar with concepts of triangle on the basis of sides and angle and Also knowledge of S.A.S., A.S.A, and S.S.S. condition.

Activities

1. In first, researcher will present the content of today. Then first few minutes of lesson hour, review the prerequisite knowledge of the students. Then content will introduce to the students and researcher will ask question related to the present topic such as: what is given, what is to prove and how prove. Also students will engage to draw diagram as well as write given, to prove and construction on their copy.
2. In second phase, researcher demonstrates related steps of theorem proof by the way writing on the board to enable the students for their work. At this time researcher will start brief discussion by the dynamic activity. Then students engage to write consequent steps own their word on their copy. The researcher will act as a facilitator to encourage students for actively participates. Then after complete proof; researcher will ask the questions to students related to theorem. In this phase, researcher will motivate students to active participation in learning in that they are imagining, communicating, exploring and expressing their ideas, while the students are dealing with activities, the researcher give feedback on the students errors and guide them about their questions.
3. In last but not least phase, researcher construct object. They observe the result of the movements. In such learning environment students create their own understanding related steps of theorem proof and these phases will revise if necessary. Finally, researcher summarizes the main points and definition also gives the home assignment as well as students will tell the next content.

Teaching Episode-4**Chapter:** Parallelogram**Section:** Theorem Proving**Time:** 45 min**Objective**

At the end of the lesson the students should be able to:

Prove the theorem that the opposite sides and angles of a parallelogram are equal by theoretically.

Prerequisites: Students are familiar with concepts of parallelogram, conditions of any two straight lines are parallel, and conditions of any two triangles are congruent.

Activities:

1. In first, researcher will present the content of today. Then first few minutes of lesson hour, review the prerequisite knowledge of the students. Then content will be introduced to the students and researcher will ask questions related to the present topic such as: what is given, what is to be proved and how to prove. Also students will engage to draw a diagram as well as write given, to be proved and construction on their copy.
2. In second phase, researcher demonstrates related steps of theorem proof by the way of writing on the board to enable the students for their work. At this time researcher will start discussion by the dynamic activity. Then students engage to write consequent steps on their own words on their copy. The researcher will act as a facilitator to encourage students to actively participate. Then after complete proof, researcher will ask questions to students related to the theorem. In this phase, researcher will motivate students to active participation in learning in that they are imagining, communicating, exploring and expressing their ideas, while the students are dealing with activities, the researcher gives feedback on the students' errors and guides them about their questions.
3. In last but not least phase researcher constructs the object. They observe the result of the movements. In such learning environment students create their own understanding related steps of theorem proof and these phases will be revised if necessary. Finally, researcher summarizes the main points and definition also gives the home assignment as well as students will tell the next content.

Teaching Episode-5

Chapter: Parallelogram

Section: Theorem Proving

Time: 45 min

Objective

At the end of the lesson students should be able to:

- Prove the theorem two line segments joining the end points of two equal and parallel line segments towards the same side are also equal and paralleling theoretically.

Prerequisites: -Students are familiar with concepts of parallelogram, conditions of any two straight lines are parallel, and conditions of any two triangles are congruent.

Activities:

1. In first, researcher will present the content of today. Then first few minutes of lesson hour, review the prerequisite knowledge of the students. Then content will introduce to the students and researcher will ask question related to the present topic such as: what is given, what is to prove and how prove. Also students will engage to draw diagram as well as write given, to prove and construction on their copy.
2. In second phase, researcher demonstrates related steps of theorem proof by the way of writing on the board to enable the students for their work. At this time researcher will start brief discussion by the dynamic activity. Then students engage to write consequent steps own their word on their copy. The researcher will act as a facilitator to encourage students for actively participates. Then after complete proof, researcher will ask the questions to students related to theorem. In this phase, researcher will motivate students to active participation in learning in that they are imagining, communicating, exploring and expressing their ideas, while the students are dealing with activities, the researcher give feedback on the students errors and guide them about their questions.
3. In last but not least phase researcher construct the object .They observe the result of the movements. In such learning environment students create their own understanding related steps of theorem proof and these phases will revise if necessary. Finally, researcher summarizes the main points and definition also gives the home assignment as well as students will tell the next content.

Teaching Episode-6**Chapter:** Parallelogram**Section:** Theorem Proving**Time:** 45 min**Objective**

At the end of the lesson students should be able to:

- Prove the theorem two line segments joining the opposite end points of two equal and parallel line segments are bisected by each other i.e. bisect each other by theoretically.

Prerequisites: -Students are familiar with concepts of parallelogram, conditions of any two straight lines are parallel, and conditions of any two triangles are congruent.

Activities:

1. In first, researcher will present the content of today. Then first few minutes of lesson hour, review the prerequisite knowledge of the students. Then content will introduce to the students and researcher will ask question related to the present topic such as: what is given, what is to prove and how prove. Also students will engage to draw diagram as well as write given, to prove and construction on their copy.
2. In second phase, researcher demonstrates related steps of theorem proof by the way of visualization to enable the students for their work. At this time researcher will start brief discussion by the dynamic activity. Then students engage to write consequent steps own their word on their copy. The researcher will act as a facilitator to encourage students for actively participates. Then after complete proof, researcher will ask the questions to students related to theorem. In this phase, researcher will motivate students to active participation in learning in that they are imagining, communicating, exploring and expressing their ideas, while the students are dealing with activities, the researcher give feedback on the students errors and guide them about their questions.
3. In last but not least phase, researcher constructs the object. They observe the result of the movements. In such learning environment students create their own understanding related steps of theorem proof and these phases will revise if necessary. Finally, researcher summarizes the main points and definition also gives the home assignment as well as students will tell the next content.

Teaching Episode-7

Chapter: Circle

Section: Theorem proving

Objective

At the end of the lesson students should be able to:

- Prove the theorem a perpendicular drawn from the centre of a circle to a chord bisects the chord.

Prerequisites: Students are familiar with concept of circle; conditions of any two triangles are congruent.

Activities:-

1. In first, researcher will present the content of today. Then first few minutes of lesson hour, review the prerequisite knowledge of the students. Then content will introduce to the students and researcher will ask question related to the present topic such as: what is given, what is to prove and how prove. Also students will engage to draw diagram as well as write given, to prove and construction on their copy.
2. In second phase, researcher demonstrates related steps of theorem proof by the way of visualization to enable the students for their work. At this time researcher will start brief discussion by the dynamic activity. Then students engage to write consequent steps own their word on their copy. The researcher will act as a facilitator to encourage students for actively participates. Then after complete proof, researcher will ask the questions to students related to theorem. In this phase, researcher will motivate students to active participation in learning in that they are imagining, communicating, exploring and expressing their ideas, while the students are dealing with activities, the researcher give feedback on the students errors and guide them about their questions.
3. In last but not least phase researcher constructs the objects. They observe the result of the movements. In such learning environment students create their own understanding related steps of theorem proof and these phases will revise if necessary. Finally, researcher summarizes the main points and definition also gives the home assignment as well as students will tell the next content.

Teaching Episode-8

Chapter: Circle

Section: Theorem Proving

Objective:

At the end of the lesson students should be able to :

- Prove the theorem the perpendicular bisector of a chord of a circle passes through the centre of that circle by theoretically.

Prerequisites: - Students are familiar with concept of circle; conditions of any two triangles are congruent.

Activities:-

1. In first, researcher will present the content of today. Then first few minutes of lesson hour, review the prerequisite knowledge of the students. Then content will introduce to the students and researcher will ask question related to the present topic such as: what is given, what is to prove and how prove. Also students will engage to draw diagram as well as write given, to prove and construction on their copy. Their researcher will discuss with students for developing the proof strategy.
2. In second phase, researcher demonstrates related steps of theorem proof by the way of writing on the board to enable the students for their work. At this time researcher will start brief discussion by the dynamic activity. Then students engage to write consequent steps own their word on their copy. The researcher will act as a facilitator to encourage students for actively participates. Then after complete proof, researcher will ask the questions to students related to theorem. In this phase, researcher will motivate students to active participation in learning in that they are imagining, communicating, exploring and expressing their ideas, while the students are dealing with activities, the researcher give feedback on the students errors and guide them about their questions.
3. In last but not least phase, researcher constructs the object. They observe the result of the movements. In such learning environment students create their own understanding related steps of theorem proof and these phases will revise if necessary. Finally, researcher summarizes the main points and definition also gives the home assignment as well as students will tell the next content.

Teaching Episode-9**Chapter:** Circle**Section:** Exercise**Time:** 45 min**Objective**

At the end of the lesson students should be able to:

- Solve the problem related to the above theorems

Prerequisites: Students are familiar with basic concepts about circle as well as have the knowledge of previously proved theorem

Activities:-

1. In first phase, researcher was presented the content of today. Then first few minute, reviewing the prerequisite knowledge of the students. After that, researcher was asks question related to the present content. Also students were engaged to draw the presented diagram on their copy. Then researcher was start discussion with students for finding the value of x and y from the given figure.
2. In second phase, researcher will start discussion with the students about figure and students are involved in the interaction to find the value of x and y . At this time researcher acted as a facilitator to encourage students for actively participate. Then, asks reason to the students behind these unknown angles and researcher gave feedback on the students' errors and guided them about their questions.
3. After measuring angle, researcher demonstrates the all solving process by writing on the board. Moreover, researcher gives such type of problem to the students by making the figure on their copy. Also researcher dragged and resized the constructed figure which was displayed on the screen dynamically. Students observed the results of the movements and created their own understanding of solving geometrical problem. Finally, researcher summarized the main points as well as gives home assignment.

Appendix –F
Score of Pretest

S.N.	Score of students in experimental Group	Scores of students in control Group
1.	25	12
2.	16	15
3.	15.5	14
4.	24	13.5
5.	13	21
6.	13.5	15
7.	15.5	9.5
8.	15	7
9.	6	16
10.	8.5	6
11.	16.5	20
12.	15	18
13.	14	
14.	17	
15.	12	
16.	13	
17.	10.5	
18.	20	
19.	15.5	
20.	13.5	
21.	24	
22.	20.5	
23.	22	
24.	25	
25.	25	
26.	29	
27.	19	
28.	19	
29.	20	
30.	21	
31.	20	
32.	14	
33.	16.5	
34.	12.5	
35.	7.5	
36.	8	

Appendix-G

Group	N	Mean	Std. Deviation	Std. Error Mean	t	df	Sig. (2-tailed)	Mean	95% confidence Interval	Lower Upper
Control	12	13.917	4.714	1.361	-1.547	46	0.129	2694	-6.200	0.812
Experimental	36	16.611	5.376	0.896						

Appendix –H
Score of Post-test

S.N.	Score of students in Experimental Group	Scores of students in Control Group
1.	28	14
2.	24	16
3.	20	16
4.	27	15
5.	18	26
6.	19	14
7.	20	11.5
8.	18	9
9.	12	17
10.	14	8
11.	20	21
12.	19	18
13.	21	
14.	24	
15.	18	
16.	19	
17.	19	
18.	24	
19.	26	
20.	19	
21.	28	
22.	28	
23.	29	
24.	26	
25.	29	
26.	29	
27.	29	
28.	24	
29.	26	
30.	28	
31.	26	
32.	24	
33.	24	
34.	25	
35.	19	
36.	14	

Appendix-I

Detailed Output Result of Posttest Comparison Group Statistics.

Group	N	Mean	Std. Deviation	Std. Error Mean	t df	Sig. (2-tailed)	Mean	95% confidence Interval		
								Lower	Upper	
Control	12	15.458	4.943	1.427	- 4.530	46	0.000	-7.236	-10.451	-4.021
Experimental	36	22.694	4.743	0.791						

Appendix-J

Detailed Output Result of Cohen's d-test

Group	N	Mean	Mean Std. Dev.	dCohen's d
Control	12	15.458	7.238	4.943
Experimental	26	22.694	4.744	7.315

Cohen's d = $\frac{\text{Mean for group A} - \text{Mean for group B}}$

Polled standard deviation

Where the polled standard deviation =

$\frac{\text{Standard deviation of group 1} + \text{Standard deviation of group 2}}$

2

Appendix-K

Detailed Output Result of students perception scale

Item	Mean	Sum of the Mean	Cronbach's Alpha	Variance	No of items
	3.523	5969.89	0.723	0.058	17