

**INCOME GENERATING ACTIVITIES OF COMMUNITY
FORESTRY USER GROUPS
(A CASE STUDY OF RAMITE COMMUNITY FOREST USER GROUPS OF
NAMADI VDC, RAMECHHAP DISTRICT)**

**A Thesis Submitted in Partial Fulfillment of the Requirement for the
Awards of the Degree of Master of Arts in Rural Development**

**SUBMITTED BY
SHANTI PD. PAUDEL
Roll No. 3990
Regd. No. 7651-87**

**Central Department of Rural Development,
Faculty of Humanities and Social Sciences
Tribhuvan University, Kirtipur
Kathmandu, Nepal
2010**



RECOMMENDATION LETTER

This thesis entitled "**Income Generating Activities of Community Forestry User groups: A Case Study of Ramite Community Forestry User Groups in Namadi VDC, Ramechhap District**" has been prepared and written by Shanti Pd. Paudel under my supervision. This is his independent work. So, I recommend it for final approval.

.....
Dr. Chandra Lal Shrestha

(Supervisor)

Central Department of Rural Development

T.U., Kirtipur

APPROVAL LETTER

This is to certify that the thesis entitled "**Income Generating Activities of Community Forestry User groups: A Case Study of Ramite Community Forestry User Groups in Namadi VDC, Ramechhap District**" submitted by Mr. Shanti Pd. Paudel has been examined. It has been declared successful for fulfillment of the academic requirements toward the completion of Master of Arts in Rural Development.

Thesis Committee

Head
Prof. Dr. Pradeep Kumar Khadka
Central Department of Rural Development
T.U., Kirtipur

External Examiner
Prof. Dr. Mangala Shrestha
Central Department of Rural Development
T.U., Kirtipur

Thesis Supervisor
Dr. Chandra Lal Shrestha
Associate Professor
Central Department of Rural Development
T.U. Kirtipur

ACKNOWLEDGEMENTS

This study, "**Income Generating Activities of Community Forestry Users Groups: A Case Study of Ramite Community Forest User Groups in Namadi VDC, Ramechhap District**" is completed for the partial fulfillment of the requirement for the Degree of Master of Arts in Rural Development.

I am highly obliged to Associate Professor Dr. Chandra Lal Shrestha who supervised this thesis throughout the period of preparation.

At this moment, I must not forget Prof. Dr. Pradeep Kumar Khadka, Head of the Central Department of Rural Development, for his cooperation.

I would like to extend my sincere thanks to all respected teachers and staffs of the Department. My sincere acknowledgement also goes to all the staffs of T.U. Central Library, Ramechhap DFO, Ramite Community Forest User Groups, Executive Member of this CFUGs, FECOFUN, study area respondents, households, who has given their valuable time to fulfill the questionnaire and for their views.

I would further express my gratitude to my guardians, brother-Kailash Dhungel, Narayan Karki, Anita Shrestha and all my friends of Rural Development senior or junior students for their full support.

2010

Shanti Prasad Paudel

ABSTRACT

Community forestry is a small scale, village level forestry practice where decisions and actions are often made on a collective basis, and where the rural population participate in forest conservation planning, establishment, management and harvesting of forest crops and receive a small proportion of the socio-economic and ecological benefits from the forest.

Community forestry was introduced in Nepal in 1978. The community forestry approach has been highly successful in the protection of the forest in the hills of Nepal. The local user groups are responsible for the control, protection, and management of the forest.

This research is done on the current issue of income generation activities. Forest as local resources are main resources and also source of livelihood of flora, fauna and human beings. This study focuses on income generation of Ramite CFUGs of Ramechhap district. The main objective of this study is to investigate on Income Generating Activities. However, other specific objectives are;

- To analyze the socio-economic status of the forest users group.*
- To asses the income generating activities of forest user groups.*

This study has adopted both the descriptive and exploratory research designs. Out of 310 households only 13 percent (40 HHs) had been selected by purposive sampling. On the process of data collection both primary and secondary sources has been used.

The above study shows that the resources of CF had changed the socio-economic status of the local communities as well as the level of

participation had been increased rapidly. But for the further work it is recommended to adopt better trainings, skills, awareness.

The study was carried out in Namadi VDC of Ramechhap district. The methodology of the study included both the qualitative and quantitative method. Data was collected through in household questionnaire with 40 households different ethnic group sampled through sample random sampling method. The major findings of the study were,

- *The forest users comprise of 8 ethnic groups dominated Chhetri 37.5%, Sunuwar 17.5%, Gharti 7.5%, Kami 12.5%, Brahmin 2.5%.*
- *Service and agriculture is the major economic activities for majority of forest users households.*
- *Average family size of lower castes as Damai, Kami, Sarki have large number (5.4) and other castes have smaller family size comparatively and total average family size is 4.725 in sample HHs.*
- *Educational status of sampled households literate 78.61 and illiterate only 21.39 but woman are illiterate in majority.*
- *The main vision of this CFUGs to reduce poverty by improving live, livelihood, agriculture and income generating program through forestry.*
- *The forest conduction is found good on the CFUGs, plants are growing day by day and the greenery of forest gives an attractive scene from which people can take a kind of pleasure.*

- *Environment is changing woman participation is satisfactory on decision and implementation of CFUGs every work.*
- *Strong co-operation and co-ordination among the users fund mobilization for IGAS is a model works paying interest at the rate of different types of IGAS.*
- *In Ramite CFUG the fuel wood has been provided equally to the users on the bass of family size.*
- *The CFP is sustainable and is very significant to meet the needs of the villagers so quite effective in the feeling of people.*
- *Labour of the people is going non-profit activities and use to agriculture as a mass production and create market and find out for grate income.*
- *The production system must be change to*
 - *One production one village.*
 - *One quality one area*
 - *One skilled one introduction*
 - *One grant one bank*
 - *One labour one confidence*
 - *One market one quantity.*

then change life style of the village people and reduce the poverty at the country.

TABLE OF CONTENTS

Recommendation Letter	i
Approval Letter	ii
Acknowledgement	iii
Abstract	iv
Table of Contents	vii
List of tables	ix
List of Figures	x
Abbreviation and Acronyms	xi
CHAPTER-I: INTRODUCTION	1-6
1.1 Background of the Study	1
1.2 Statement of the Problem	1
1.3 Objectives of the Study	3
1.4 Importance of the Study	4
1.5 Limitations of the Study	4
1.6 Organization of the Study	5
CHAPTER-II: REVIEW OF LITERATURE	7-22
CHAPTER-III: RESEARCH METHODOLOGY	23-25
3.1 Research Design	23
3.2 Sample and Sampling Procedure	23
3.3 Sources of Data Collection	24
3.4 Data Collection Tools and Technique	24
3.4.1 Questionnaire Survey	24
3.4.2 Key Informant Interview	24
3.4.3 Field Observation	24
3.4.4 Focus Group Discussion	25

3.5	Data Processing	25
3.6	Data Analysis	25

CHAPTER - IV: INTRODUCTION OF THE STUDY AREA 26-36

4.1	Country Background	26
4.2	Glimpse of Ramechhap District	26
4.2.1	Geographical Condition	28
4.2.2	Major Ethnic Composition in Ramechhap District	28
4.2.3	Socio-economic Situation	28
4.2.4	Land Use	29
4.2.5	Climate and Soil	29
4.2.6	Community Forestry in Ramechhap	30
4.2.7	Religions Composition of Ramechhap District	31
4.3	Village Profile	31
4.4	Description of the Selected CFUGs	36

CHAPTER-V: SOCIO-ECONOMIC STATUS OF THE STUDY AREA 37-50

5.1	Total Number of Households and Sample	37
5.2	Ethnic Composition of Sampled HHs	37
5.3	Family Sizes of Ethnic Groups	39
5.4	Sex Composition of Sampled HHs	39
5.5	Educational Status of Sample Household According to Sex	42
5.6	Occupational composition of sampled Households	44
5.7	Distribution of Livestock Holding in the Sampled Households	45
5.8	Feeding Pattern of Livestock in Sampled HHs	46
5.9	Distribution of Land Holding in Sampled Households	46
5.10	Crops Production of Sample Households	47
5.11	Well-being Ranking of Sampled Household	49

CHAPTER - VI: INCOME GENERATING ACTIVITIES		
OF CFUGS		51-57
6.1	Introduction	51
6.2	Income Generating Activities of Ramite CFUG	51
6.2.1	Amliso (Broom Grass) Farming	51
6.2.2	Turmeric Farming	52
6.2.3	Other Sources of Income for CFUG	53
6.3	Sources of Income for Sampled Households	55
6.4	Annual Income of the Sampled Household	57

CHAPTER-VII: SUMMARY, CONCLUSION AND		
RECOMENDATONS		58-61
8.1	Summary	58
8.2	Conclusion	59
8.3	Recommendations	60

BIBLIOGRAPHY

QUESTIONNAIRE

LIST OF TABLES

Table No. 2.1 : Different Capitals and Their Fields of Research and Nature of Policy	16
Table No. 4.1 : Land Holding Pattern in Ramechhap District	30
Table No. 4.2 : Religious Composition of Ramechhap District	31
Table No. 4.3 : Household having Agricultural Land, Livestock and Poultry for Namadi VDC	33
Table No. 4.4 : Total Number of Population According to Caste Groups	34
Table No. 4.5 : Population 6 Year of Age and Over by Literacy Status and Sex for VDC	35
Table No. 5.1 : Ethnic Composition of Sampled HHs	38
Table No. 5.2 : The Family Size of Ethnic Groups in Sample HHs	39
Table No. 5.3 : Sex Composition of Sampled Households	40
Table No. 5.4 : Educational Status of Sampled Households	43
Table No. 5.5 : Occupational Composition of Sample Households	44
Table No. 5.6 : Distribution Livestock Holding of Sample Households	46
Table No. 5.7 : Distribution of landholding pattern in Sample Households	47
Table No. 5.8 : Distribution of Crops Production in Sampled Households	48
Table No. 5.9 : Well-being Ranking of Sampled Households	49
Table No. 6.1 : Average Annual Income of Samples HHs in Ramite CFUG.	57

LIST OF FIGURES

Figure No. 1	: District Map of Ramechhap (Land use map)	27
Figure No. 2	: Land Use Pattern in Ramechhap District	29
Figure No. 3	: VDC Map	32
Figure No. 4	: Population 6 Year of Age and Over by Literacy Status and Sex for VDC	35
Figure No. 5	: Ethnic Composition of Sampled HHs	38
Figure No. 6	: Educational status of sampled Households	43
Figure No. 7	: Occupational Composition of Sample Households	45
Figure No. 8	: Distribution of Land Holding Pattern	47
Figure No. 9	: Distribution of Crops Production in Sampled Households	48
Figure No. 10	: Well-being Ranking of Sampled Households	50

ABBREVIATIONS AND ACRONYMS

BS	–	Bikram Sambat
CBS	–	Central Bureau of Statistics
CF	–	Community Forestry
CFP	–	Community Forest Programme
CFUGs	–	Community Forest User Groups
DDC	–	District Development Committee
DFID	–	Department for International Development
DFO	–	District Forest Office
etc	–	Etcetera
FECOFUN	–	Federation of Community Forest Users, Nepal
FY	–	Fiscal Year
GDP	–	Gross Domestic Product
ha	–	Hectare (1000 Square Meters)
HHs	–	Households
HMG/N	–	His Majesty's Government of Nepal
i.e.	–	That is
IGAS	–	Income Generating Activities
INGOS	–	International Non-Government Organizations
K.M.	–	Kilometer
LFP	–	Livelihoods and Forestry Programme
MOF	–	Ministry of Finance
MPFS	–	Master Plan for the Forestry Sector
NGOs	–	Non Government Organization
No.	–	Number
NPC	–	National Planning Commission
NRs	–	Nepali Rupees
NTFPs	–	Non-Timber Forest Products

NUKCFP	–	Nepal UK Community Forestry Project
PAF	–	Poverty Alleviation Fund
PRA	–	Participatory Rural Appraisal
RP	–	Range Post
Rs	–	Rupees
Sq.	–	Square
UGC	–	User Group Committee
UNDP	–	United Nations Development Program
VDCs	–	Village Development Committees
WDR	–	World Development Report

**INCOME GENERATING ACTIVITIES OF COMMUNITY
FORESTRY USER GROUPS**

**A CASE STUDY OF RAMITE COMMUNITY FOREST USER GROUPS OF NAMADI
VDC, RAMECHHAP DISTRICT**

**A Thesis Submitted in Partial Fulfillment of the Requirement for the
Awards of the Degree of Master of Arts in Rural Development**

**SUBMITTED BY
SHANTI PD. PAUDEL
Roll No. 3990
Regd. No. 7651-87**

**Central Department of Rural Development,
Faculty of Humanities and Social Science
Tribhuvan University, Kirtipur
Kathmandu, Nepal**

2010

CHAPTER-I

INTRODUCTION

1.1 Background of the Study

Nepal is land-locked country which covers 1,47,181 sq.km. area of world. It is a country of rural areas in which more than 85% people are living in rural areas. It is one of the least development country of world. But it is very rich in term of forest resources and bio-diversity. The forest resource has made a significant contribution to economic and social development of the country.

Natural resources refer to any portion of the natural environment such as atmosphere, water, soil, forest, wildlife, land, minerals and environment asset. It is a relative term as it may vary different from society to society in its importance. On its broad classification come the renewable and non-renewable natural resources. The abiotic resources as natural gas, petroleum, coal, mines and metals come under the non-renewable resources while mostly biotic resources as farming, water, forest and sun are renewable natural resources.

Forest is one of the important natural resources for raising socio-economic status of the local people. Forest directly fulfills forest related substitutions need of women, poor and backward people. Forest has been providing inputs for agriculture, livestock and it supplies medicinal herbs, timber and non timber forest products. It also conservers watershed, improves the condition of the soil and provides recreation for tourists through forest based eco-tourism national park and wildlife reserves.

Similarly, it is providing a habitat for flora and fauna. It also providing raw materials for forest related industries.

Once the forest know as the chief wealth of the country, which proves the popularly known proverb; 'Hario Ban Nepal Ko Dhan: Forest alone contributes 10% to total national GDP, live stock get 40% of total fodder from forest foliage (Ban Ko Jankari, 2005); Fuel, wood contributes about 76% of the total energy sources used in the country, which also comes from forest. Also much of the agricultural system are directly based on the forest (NPC, 1998).

In the context of Nepal, forest cover was more the 45% of total area of the country in 1964. This has been reduced to 29% by 1998 (NPC, 1998). The population of Nepal has grown during last decade of the rate of 2.2% per year. Where as forest has been degraded at on annual rate of 1.7% per year. This has been creating many problems to the mankind and the environment.

In Nepal, community forest programme was started in 1979. Although it is a new programme it has developed dramatically in the last decade. Large areas of forest cover area being brought under community forest management. This is one of the successful programmes and is based on the concept of peoples participation. The main focus of this programmes is to involve local community in forest management.

Community forest comprises the most focused area of forest management in Nepal, especially in the hill districts. Community, forests encompass those parts of 'National forest' that have been 'handed over' to a community forest user group (CFUG). The CFUG is entitled to develop,

conserve, use and manage the forest and sell and distribute forest products by independently fixing the price.

During, the past 29 years of community forest implementation, about 1.2 million hectares of National forest has been handed over to more than 14,000 local community forest user groups involving 1.6 million households. The user groups cover about 35 percent (%) of the country's total population. The achievement of the community forestry can be seen in terms of better forest condition, better mobilization and income generation for rural development and institutional building at grass-root level (Kanel, 2006).

1.2 Statement of the Problem

Due to high growth rate of population the forest resources has been declining day by day. The rapid growth of population exerts pressure on the available farm land as it will not be sufficient to feed the growing peoples. So, the people, mainly the poor start cultivating the marginal land by clearing the forest resources declining area.

In 1964, about 45% of the total area was covered by forest. This area declined to 43 percent in 1979 and in 1986 it still declined to 37.4 percent, recent survey show that the forest sector covers only 29 percent of the total land area of the country in 1998 (NPC, 1998). This fact clearly shows that the forest resources has been exploited regularly. Government introduced several hard rules for forest management but could not control. It is realized that without the active participation once-operation of the local people, the forest conservation and utilization policy will not be

effective and sustainable. Therefore, to tackle these problem/community forestry was introduced.

Now, there is a need for reviewing and examining the effectiveness of community forest and find out solution for its further improvement in its mode of operation. The present study attempts to explore the existing knowledge and working model at community forest of the study area.

The policy of community forestry is very good in rhetorical perspective but in reality higher class user groups are taking more benefit than lower class user groups. The main problem is policy gap between rich and poor user groups.

1.3 Objectives of the Study

Generally, this study has focused 'Income Generating Activities of Forest User Group' of the study area. The specific objectives have been set as follows:

1. To analyze the socio-economic status of the forest user group.
2. To assess the income generating activities of forest user groups.

1.4 Importance of the Study

Forest resource is the main parts of natural resources many more things is being provided by forest to the environment. Such as, ecology balance, fodder, leaf, liter, water sources etc. It covers the area of 29 percent of the country.

Community forestry programme is very effective in a rural agrarian country like Nepal. It makes people feel that the forest belongs to them

and they took after in carefully. Different types of income generating activities have been started by users to improve their livelihoods.

There has been so many researches and studies regarding community forestry programme but in the hilly region of Nepal specially Ramite Kati Community Forest Namadi VDC of Ramechhap District, there have not been any satisfactory studies. In other words, it is a virgin area from the view points of research.

Therefore, the present study is focused on virgin area to explore something inside the community forestry with field level data. It is hoped that the outcome of the study will be helpful to introduce different types of benefits derived from community forest programme.

1.5 Limitations of the Study

Followings are the limitations of this study

1. This present study has focused on only Ramite Community forestry Namadi VDC Ramechhap district. Therefore, the findings of the study may not give the whole picture of other groups.
2. The study has conducted within the given time and financial limitation.
3. The study has focused on income aspect of the households only.
4. Simple statistical tools are used to analyze the data obtained.

1.6 Organization of the Study

The study encompasses seven chapters. The first chapter introduces the background: Introduction, statement of problem, objectives, importance, limitation and organization of the study. The second chapter describes the review of literature. The third chapter deals with the research methodology of the study. The fourth chapter introduces the introduction to the study area. The fifth chapter deals with the socio-economic status of the study area. The sixth chapter describes the income generating activities of CFUGs in the study area. And the last chapter describes major findings, conclusion and recommendations. At the end bibliography is presented

CHAPTER-II

REVIEW OF LITERATURE

There are many scholars and researchers who have devoted their time studying forestry issues in Nepal. Their efforts to find out the forestry problems and solutions are considered valuable contributions. However, here only some literatures of scholars and researchers have been reviewed in order to know about the existing status of community forestry in Nepal.

"Hariyo Ban, Nepal Ko Dhan" i.e. Green forest is Nepal's wealth" is an old slogan showing people's perceptions to Nepal's forest resource. It proves that the forest is one of the most important resources of Nepal. But now a days, the Nepalese forests are being destroyed at a, speed which is hard to imagine.

In the past, the population was less and people lived in close harmony with nature and gave top priority to the conservation of forest resource. In those days forests were looked upon as sources of subsistence and vital source for maintaining life supporting system. There was strict social control on the cutting of trees in the past. So the forest was remained in a good condition. In the Lichhavi period even to enter the forest, king's permission was needed. During Ram Shah's regime even dry leaves were charged.

According to Fisher and Gilmour (1991), the deforestation in Nepal started form eighteen Century. After the unification of Nepal, the government took little interest in forest management. Land policy in the hills was designed to encourage the conversion of land from forest to agriculture in order to increase the tax base. People were awarded by the

government with Birta lands if they undertook to reclaim virgin forest lands and bring it under cultivation. Such lands were granted tax exemption for some period as an incentive.

Regmi (1978) has concluded that the Ranas also did not change their view about forest because land was still the principle economic resource of the nation. They encouraged and pushed Jamindars or Birtawals to the terai and encouraged as much as possible to be brought into cultivation. About one third of the total forest and cultivated lands were under Birta tenure and 75% belonged to the members of the Rana family. During this period there were British rulers in India. The Rana rulers initiated a number of measures to maximize revenue from the timber export trade with India. In this way trees were indiscriminately felled to supply timber for buildings, ships and railway lines and to provide fuel for the ships and trains.

Bajracharya (1983) mentioned that the planning and control of forests by the government made people think negatively towards forest. Heavy deforestation took place as the villagers felt that their forests have been taken away by the government. The villagers have a strong incentive to destroy the forest so that the land could be claimed as private property.

Community forestry has involved to establish a suitable management of forests at local level. Rural communities have had significant achievements in meeting their forestry needs, generating and utilizing funds for community welfare, and conserving the forest as well. However, the management of community forestry will be at risk if the existing institutional arrangements within the user groups are not

improved and user groups do not strive to attain a suitable security for subsistence before migrated market economy.

Community forestry in Nepal has now found a certain direction through the support of forestry policy, legislation, departmental guidelines and extension oriented forestry, staff, passing over different obstacles and difficulties (Singh, 1998).

Community forest is a partnership programme between government and community organization in which government staff plays roles as facilitation and catalyst to identify real user groups to prepare operational plan of forest and constitutions of group and in implementation of community forestry activities. Whereas the community (user group) is responsible to manage, protect and utilize the forest in the sustainable basis.

A book prepared by Kafle (2000) pointed out that the Department of Forest has difficult task to protect effectively manage and sustainable use of the nation's forest resources. Most forest district offices had inadequate staff. So, it was not possible for the staff to protect the forest. Therefore to solve the problems new forest management acts were introduced.

Between 1957 and 1978 several laws and acts were passed defining the government authority over the forest and regulating the use of resources. Forest Act 1961 was first comprehensive forest legislation in the history of Nepal. It was an attempt to Institute the better management of the forest. Due to the political change in 1960. Nepal introduced a Panchayat system of government. The forest Act of 1961 which followed this change made provision for land to be made available for small private forest plots and introduced the idea of transferring government land for the use of Panchayat (Mahat et al. 1987).

Government Introduced several rules for forest management but could not be controlled and managed which resulted a high rate of deforestation by the large private owners: Most people had, come to believe that government forest belonged to nobody. They still needed forests products and damaged it continuously. On other hand the government did not realize the basic forestry needs of rural people and tried to keep them out of the forests, but there was no alternative for the people except illegal collection of forest products. As a result between 1963 and 1979, 500000 'hectars of forest land were cleared and about one million hectars of forest was regarded in terai and Dun valley (Bajracharya, 1993).

The first social or community forestry is believed to have orginated in Gujrat of India and was conceived as an approach to first development and first conservation (Kayastha, 1991). In India attempts to engage communities in tree growing data back to the 1950s through few results were obtained from early efforts.

National Forestry Plan was formulated in 1976 by a conference held in Kathmandu in 1975 to consider various issues relation to the mal management of forest in Nepal. It was attended by District Forest Officer- from throughout the country and senior members of Forest Department and Ministry. It was remarkable that the planned three days meeting extended to 23 days because of the great interest. That was generated and the desire to make a strong statement on the need to address the deteriorating condition of the country's forests (Mahat, et al. 1987).

The master plan for the forestry sector further boost the community forestry approach by stressing the need for management plans to be

developed at FUG level and identified all the forest development staff as extension agents Nepal's total forest area is 5.46 million hectares which are about 37 percent of the total area. Out of the total forest area, 62 percent of the forest is proposed as potential community forests.

Upreti (2000) stated that the community forestry have positive impacts on gender, equity, poverty, biodiversity and forest management which are significantly contributing to social change. The poverty reduction aspect is relatively weak as compared to the achievement made on gender and equity. The level of awareness is increased where by quantity and quality of participation of users poor, women, untouchables etc. is improved.

It is possible from community forestry to reduced poverty by securing resources for the poor, increasing the availability of resources and providing potential for income generating activities. Community forestry contributes to improve people's livelihood. It has contributed significant in building social capital.

The conference was followed by the formation of a working group charged with the tasks of formulating a plan to guide the future development of the forestry in Nepal. This culminated in the publishing of National Forestry Plan in 1976. National Forestry Plan (NFP) classified national forest in to four different categories according to use i.e.

Panchayati Forest (PF)

Panchayat Protected Forest (PPF)

Religious Forest (PF)land

Leasehold Forest (LF)

The promulgation of the NFP provided a policy base for instating forestry development.

The government forest to Panchayati Forest or Panchayat Protected Forest followed by the approval of management plan by the District Forest Officers. The rules and regulations were initiated which would govern the handing over of limited areas of government forest land to the control of the Panchayats. Therefore, formal recognition of the rights of villagers to manage their own forest resources with technical assistance is being provided by the forest department.

According to Karmacharya (1987) only 36,376 hector was handed over to Panchayati Forest or Panchayat Protected forest in 29 districts. Regmi, (1984) found that the control of community forests to be managed by local people were further strengthened by the provision of the decentralization act 1982. The community forests were passed to the users group as Panchayati Forest (PF) and Panchayat Protected Forest (PPF). Truly, Speaking the National Forestry Act 1976 played a key role in introducing community forestry and moreover the decentralization act 1981 became the next pillar for the development of community forestry.

The Master Plan for the Forestry Development was formulated in 1987-88. This plan touched all the forestry related issues and activities and emphasized on community forestry. Now community forestry has been the main forestry sector policy of government of Nepal.

Rana (1996) in his case study concludes that the community forestry had direct impact in the day to day lives of people of the villagers. The level of income has been effected positively. Community Forestry programme has been a vital necessity in providing the users with

forest product, Fodder and firewood supply has increased. He recommended in his study that the NGOs, INGOs and government sectors must devote further to expand community forestry in every villagers in the hills of Nepal.

Aryal (2000) found in his study that the community forestry in village is now the main source of fuel-wood, fodder for livestock and timber for villagers. From livestock milk, meat were sold to Banepa and Kathmandu became a major source of IGA to the people. Many NGOs and INGOs were supporting different community forestry. He suggested that the government and NGOs should be encouraged to work on community forestry based programmes. More awareness programmes should be implemented . Different kinds of training should be given to the user's group.

Prasai (2000) has out pointed in his dissertation that the community forest has fulfilled the different types of forest product wants. He noticed that the community forest was saving the time of people. If there was no community forest the house it had to spend more time for: collecting fuel wood and fodder. They used this saving time for other income generating work. He recommended in his study that the more awareness programmes are necessary to increase the use of improved stove, kerosene stove, bio-gas etc. to decrease the pressure on continuity forest for fuel-wood.

The Eight Plan (1985-1990) had taken a target of 5004 CFUGS formation but it could take the progress only 5314 CFUGs.

The community forestry has been receiving British aid from 1993. The Nepal UK Community Forestry Project (NUKCFP) is in operation. It worked in 4 districts of Koshi Hills and 3 districts of Dhaulabari Hills. A great success Dhaulagiri has been achieved during NUKCFP In the

formation of local level communities groups and developing mechanism to protect and manage forest.

Income Generating Activities (IGAs) are operated by some forest user groups in Koshi hills through NUKCFP initial grants and DFO support. The majority of the activities are concerned with inter-cropping in community forest. The CFUGs has been operating these activities with the main purpose of raising FUG's fund and to provide income/employment opportunities.

According to the report of Thapa, et. al. (1996) NTFPs (Non-Timber Forest Products) such as Bamboo, Cardamom, Ginger, Amliso, Chiraito, Turmeric, Lokta and Livestock are the main sources of IGAs which have been done in Koshi Hills on support of NUKCFP. NTFPs have the great importance to raise the economic status of village as well as nation.

K.C. (1993) in his report from four districts (Viz. Dhankuta, Sankhuwasabha, Ramechhap and Terhathum in Koshi hills) found that there were 291 FUGs in Koshi Hills up to December 1993 and only 17 CFUGs (15 FUG in Dhankuta, 2 FUGs in Terhathum) had applied for received project's grants to operate IGAs. Some other FUGs have been operating similar activities by their own investment or by the support from other sources.

In the study of Maharjan, et al. (1991) it is mentioned that 205 FUGs have received "seed money" from the project as financial support to introduce different types of IGAs through NTFPs in the Koshi hills and the CFUGs collected NTFPs worth NRs. 2,938,000. Some FUGs have introduced IGAs through their own fund which is not included in the project record. This shows that the Koshi Hills have a large potentiality to

mobilize its NTFPs to support the livelihoods of the poor, the women and minority groups.

Edwards, et. al. (1994) reported that about 100 varieties of NTFPs are exported to India from Nepal. Out of total quality of NTFPs exported "Chiraito" comprised about 50%. Edward (1994) found in his research that in some areas NTFP collection alone contributes on average 50% households' income.

Dahal, et. al. (1997) in a discussion paper pointed that up to July 1997, 292 CFUGs, in the Koshi hill area were involved in agro-forestry and animal based NTFP management. This paper also cleared some main reasons for inadequate management of NTFPs eg. lack of institutional capacity, lack of infrastructure (road, processing plants) under developed marketing mechanism, lack of clear-cut strategy guidelines and commitment by government to implement NTFP management plans and policy. In addition to that authority to manage NTFP" is not clear.

After the achievement of a great success from NUKCFP the livelihoods and forestry programme (LFP) has been applied in Koshi hills which is a bilateral programme of Government of Nepal and Department for International Development. United Kingdom LFP aims `to contribute to reduced Vulnerability and improve livelihood for poor rural people. It enhances the assets of rural communities through the promotion of more equitable, efficient and sustainable use of forest. resources (LFP, 2002).

LFP, this ten-year DFID programmestarted in April 2001, to operate in Sever hill districts, Dhankuta, Terhathum, Sankhuwasabha. Ramechhap of Koshi hills area . It focuses on forestry as a vehicle to improve the livelihoods of the rural poor of Nepal (LFP, 2002).

Department for International Development (DFID) comments some issues on poverty alleviation and uses an asset pentagon to show the different levels of assets available to individual.

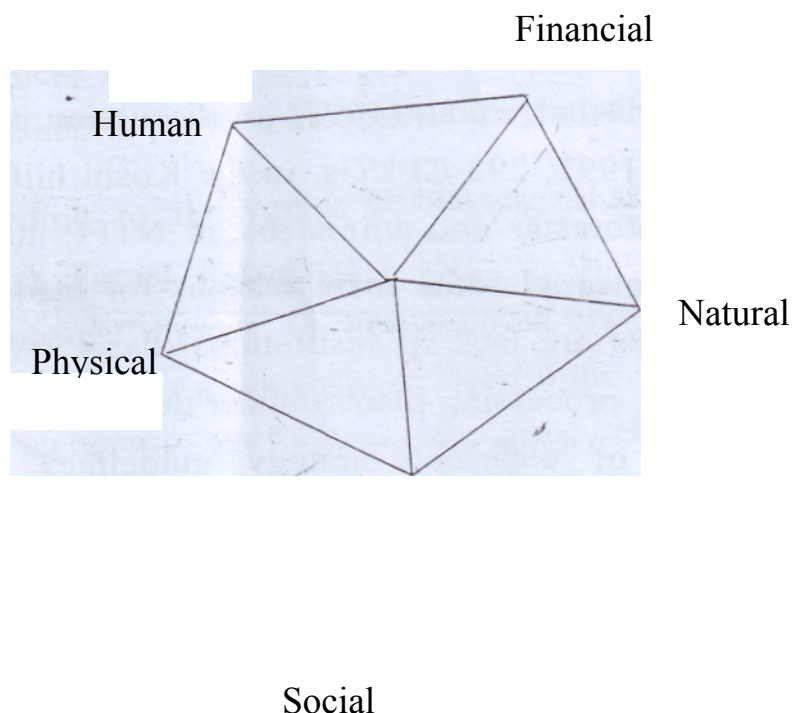

Source : DFID's Sustainable Livelihood's Guidance Sheets (DFID, 1998).

These assets are some times referred to as capital assets. Capital value of assets, can be accumulated and transferred, but it can also be depleted (Johnson, 1997). All these assets are come very different fields of research and they all have different policy levels affecting them.

Table No. 2.1: Different Capitals and Their Fields of Research and Nature of Policy.

Types of Capital	Definition	Field of Research	Area of Policy
Natural Capital	Natural resources such as forestry from which	Soil Science, Natural resource management, water management, etc.	Policies are technically and concerned with sustainable management

	<p>people gain useful products and services.</p> <p>Access to and quality of resources are important issues.</p>		
Human Capital	<p>Skill, knowledge, ability to labour, good health enable people to pursue and achieve livelihood strategies and objectives</p>	Medicine, Education	<p>Policies are concerned with increasing individual capabilities, literacy classes, health issues, and family planning</p>
Social Capital	<p>Social resources, which people draw in to pursue livelihood objective .</p>	Sociology, Gender	<p>Gender issues, decision making power, trust and reciprocity.</p>
Financial Capital	<p>Financial resources people use to achieve livelihoods objectives</p>	Economics	<p>Increasing incomes, Micro finance and Micro credit, income generating activities</p>
Physical Capital	<p>Basic infrastructure and producer goods needed</p>	Construction	<p>Access to clean water, roads, electricity and schools.</p>

	to improve livelihoods.		
--	-------------------------	--	--

Source : DFID's Sustainable Livelihoods Guidance Sheets 1998.

Similarly, the pentagon is presented in a very simple way, making it look the assets with all their different policy can be combined together to achieve the common goal of poverty alleviation. It is implied that policies from such diverse fields can easily be combined together and will fit smoothly resulting in the improvement of livelihoods. Although the types of capital are very disparate in nature, they are complementary. One policy alone is unlikely to improve the livelihood of an individual. For instance building a road has a positive impact by reducing the time taken to places, but this alone is unlikely to improve livelihoods.

LFN has taken an aim to develop all these assets to achieve its goal.

There are great potentiality of NTFPs in Ramechhap which are main sources of IGAs for the people. The main objectives of IGAs in LEP area are as follows :

- to create opportunities of employment and income generation for rural people through forestry and non-forestry IGAs.
- to maximize the return from forests through intensive and sustainable use of land.
- to encourage participation of poor and women members of the communities in decision making and benefit sharing in CF.
- to improve market access and information system related with NTFP enterprises for FUGs (Dev. 2001).

According to Tenth Plan (2002-2007); Nepal has been able to introduce itself as a country of Community Forestry in the world. With the help of Community forestry, Nepal has improved in the Field of forest, environment, bio-diversity and sustainable management and socio-cultural development. Through the medium of social justice and social improvement etc. have been launched in the local community. Community forests have been handed over to the local communities to improve the livelihoods C people below the poverty line (NPC, 2003).

According to Interim Plan (2007-2010), to stop the encroachment of forest, commercialization of its products, conservation and utilization of herbal products and the overall long term management of the forest areas are its major challenges. To develop internal market, promote exports, and generate employment by promoting forestry and forest-base industry, ensure regular supply of forest-based products by long term management of aquatic and geographical diversity, forest, plants, following policies are to be implemented:

- The necessary legal provision and procedural process are respected reformed to effectively manage the development of forestry.
- For the long term development of forest and aquatic areas, the peoples' participation are to be ensured thereby generating opportunities for the income from long-term management of forest, forest-related products, herbs, land and aquatic, environment, geographical diversity and forest related products' business.
- The reach of the poor are to be ensured by justifiable distribution system and community forest management, long-term forest management and by increasing forest-based products and its

supply.

- Some 35 per cent of the income of the community forestry are respected invested on the dalit, indigenous, nationalities, madeshi, handicapped, women and poor people's productive business.
- The reach of indigenous nationalities and the locals are to be ensured in the community forestry and its management.
- Monitoring of community forestry are to be made effective.
- The total area covered by the forest are to be marked.
- Programmes are to be brought by reforming necessary policies for the long-term management of aquatic area.
- Priority are to be given to local Tharu community, indigenous nationalities and madeshi (Muslim and backward community) in Terai for the management of community forestry.
- Forest development fund are to be set up by collecting fixed percentage of amount from buyers while selling forest-related products and a fixed percentage from the revenue generated by the sale of these products. The amount are to be used in the tree plantation and long-term forest management and poverty alleviation.
- The wasted land on the river banks are to be conserved and utilized, and bonded- forest programme are to be expanded to improve the livelihood of the families under the poverty line.
- Forest, agriculture, land and water conservation like related subjects are to be managed in a unified manner.

- A package programme are to be brought for Seti, Mahakali, Rapti, and Karnali by declaring them Herbs Zone.
- A special programme are to be brought for the people of Himalayan region for the conservation, management, and promotion of hers and forest animals.
- The western Himalayan region are to be declared a conservation area and programme are to be brought for its special conservation and social development.
- The role of the local community are to be increased in the management of conservation area.

Conceptual Framework of the Study

The framework of this research shows that community forestry is the 'Yam' of local rural communities. CF define as protection management and participation of local people. It helps to the local people directly and indirectly involves various sectors. The following diagram describes the role of community forestry in the subject of income generation as well as local people participation.

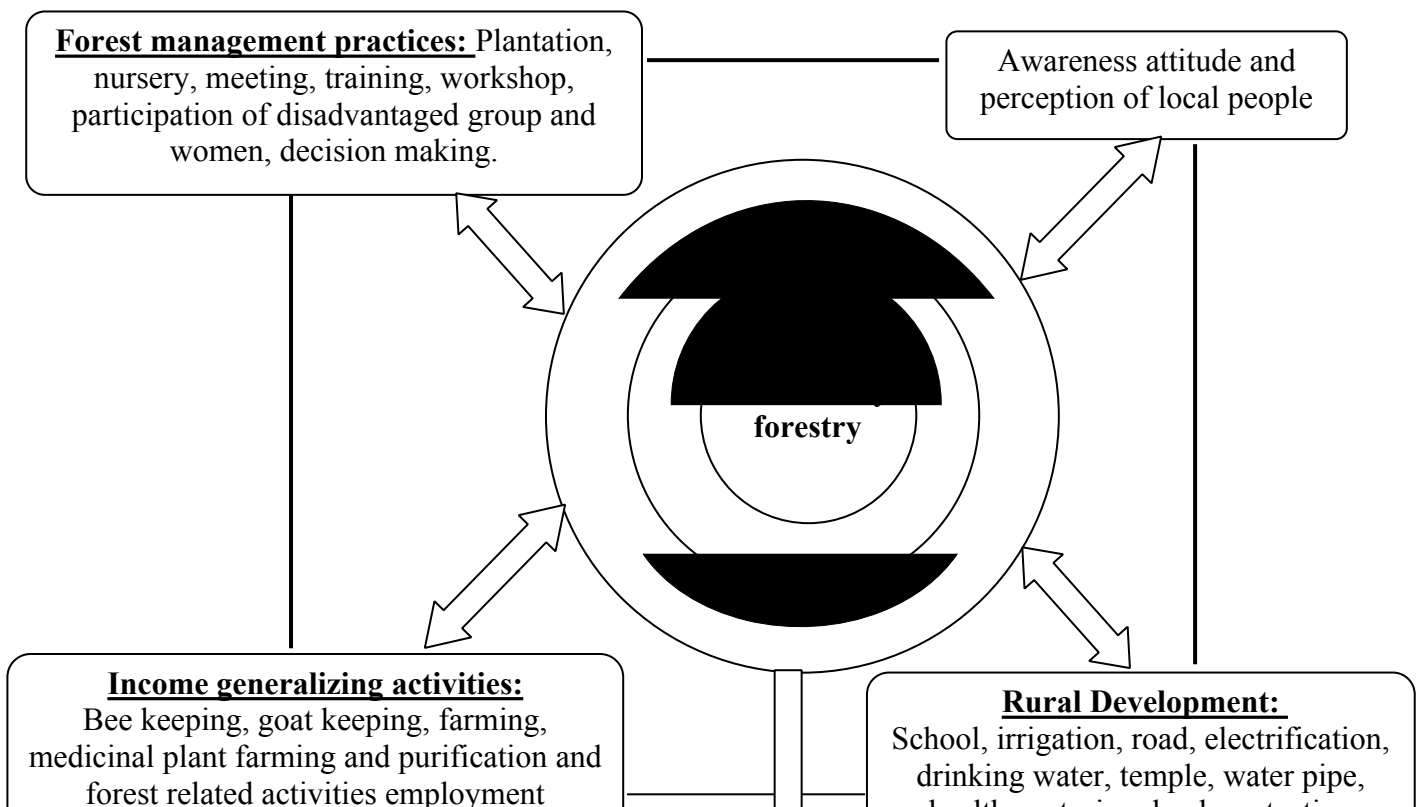

After the emergence of the community forest approach of this study
Source: Forestry Bulletin, 2060
area various developmental activities like, rural infrastructure
development, income generating activities, a forest management practices
and people's participation like decision making also

CHAPTER-III

RESEARCH METHODOLOGY

Research methodology is the most crucial and determining elements for the soundness and reasonableness of research output in any field of study. In this chapter includes research design, population of the study, sample and sampling procedure, source of data, data collection tools and techniques, data processing and data analysis respectively.

3.1 Research Design

The study has adopted both the descriptive and exploratory research designs. Descriptive research design is concerned with the describing the characteristics of a particular individual, as of a group. Community forest user group's character and their rules and process in community forestry activities are descriptively discussed. Exploratory research design finds out some problems and then analyses these problems applying different research methods.

3.2 Sample and Sampling Procedure

The study had been selected the community forestry user group at Namadi VDC Ward No. 4, 5 and 6. Out of 310 households, 13 percent 40 households had been sampled with purposive sampling method:

3.3 Sources of Data Collection

The present study is based on both primary and secondary data. The primary data had been collected from the field of the study area. Similarly, the secondary data had been used for the deep study which are collected from published or unpublished written documents, individuals experts and organization related to forest.

3.4 Data Collection Tools and Techniques

On the process of data collection tools and techniques are important. The collection of primary data had been done with the help of structured questionnaire, field observation, FUGs meeting observation, household head interview as well as focus groups discussion methods.

3.4.1 Questionnaire Survey

Structured questionnaire had been prepared to generate the realistic and actual data from households survey of the participated households. The respondents have requested to fill up the questionnaire.

3.4.2 Key Informant Interview

The primary data had been collected from key informants using semi or unstructured questions. The interview had been taken as cross checking for data obtained from questionnaire.

The informant had been interviewed on the impact of community forestry on local activities like development, income of user groups, living standard. In this process, information had been taken from politician, VDC secretary, chair-person of user groups, local teachers, social worker and so on.

3.4.3 Field Observation

Forty HHs which were selected by purposive sampling had been visited and income generation activities had been observed in various sectors. And it has been recorded in file. This was very useful to know that what was recently happening in the study area.

3.4.4 Focus Group Discussion

The focus group discussion had been located in the famous place of village with active participation of all; men, women, ethnic groups, children, youths and old persons. The discussion was started focusing the community forestry activities in local area and its impact on income generation activities and on more issues.

3.5 Data Processing

The table is formulated from questionnaire and interview about income, family size, educational status, production etc. Some summary measure like percent, mean are used to make results.

3.6 Data Analysis

After finishing interview schedule from field observation collected data had been processed. Simple statistical tools like table, graphs, bar diagram, pie chart etc. has been used for data analysis. In this stage, descriptive method was used for qualitative data.

CHAPTER - IV

INTRODUCTION OF THE STUDY AREA

4.1 Country Background

Nepal is the small landlocked country with the area of 147181 sq. km. (14.7 million hac.) located between two huge countries: China and India. She lies between 26⁰22" to 30⁰27" north and 80⁰12" to 88⁰12" east. She has huge diversity in culture and ecology although she is one of the poorest countries in the world. The country has wide range of biological diversity and five physiographic zones viz.: Terai, siwalik, middle mountains, high mountains and high Himal (HMG/N, 1998). Country includes 21 million people with different ethnic groups, cultures and castes. Forests cover about 38% of the country including 59% broad-leaved stands, 24% mixed conifer broad leaved stands, and 17% conifer stands from tropical to alpine climatic zones. The forestry sector contributes the national economy by providing 16% of the country's GDP and employing 18% of the total labor force.

4.2 Glimpse of Ramechhap District

Ramechhap district is recognized as less an industrial district which lies in Janakpur zone, the central development region of Nepal with an area of 1564.33 sq. km. and its headquarter is at Manthali RCP district consists of two major types of physiographic, viz. shadows of a Mahabharat hill that is in the southern side with steep slopes and Numbur Himal, which is rugged in all aspects. The (Tame and Shailung) Thodung, Nopra are dissected by many shallow rivers and streams, which change course from time to time. Main rivers are Likhu, Khimti, Tamakoshi, Sunkoshi, Chauri Khola and others are Tilpang, Pharpu, Haluwa, Palati, Chahare, Sabra, Sapsu, Ghyang Khola, Bhatauli Jatapokhari and Pachin Pokhari.

Figure No. 1: District Map of Ramechhap (Land use map)

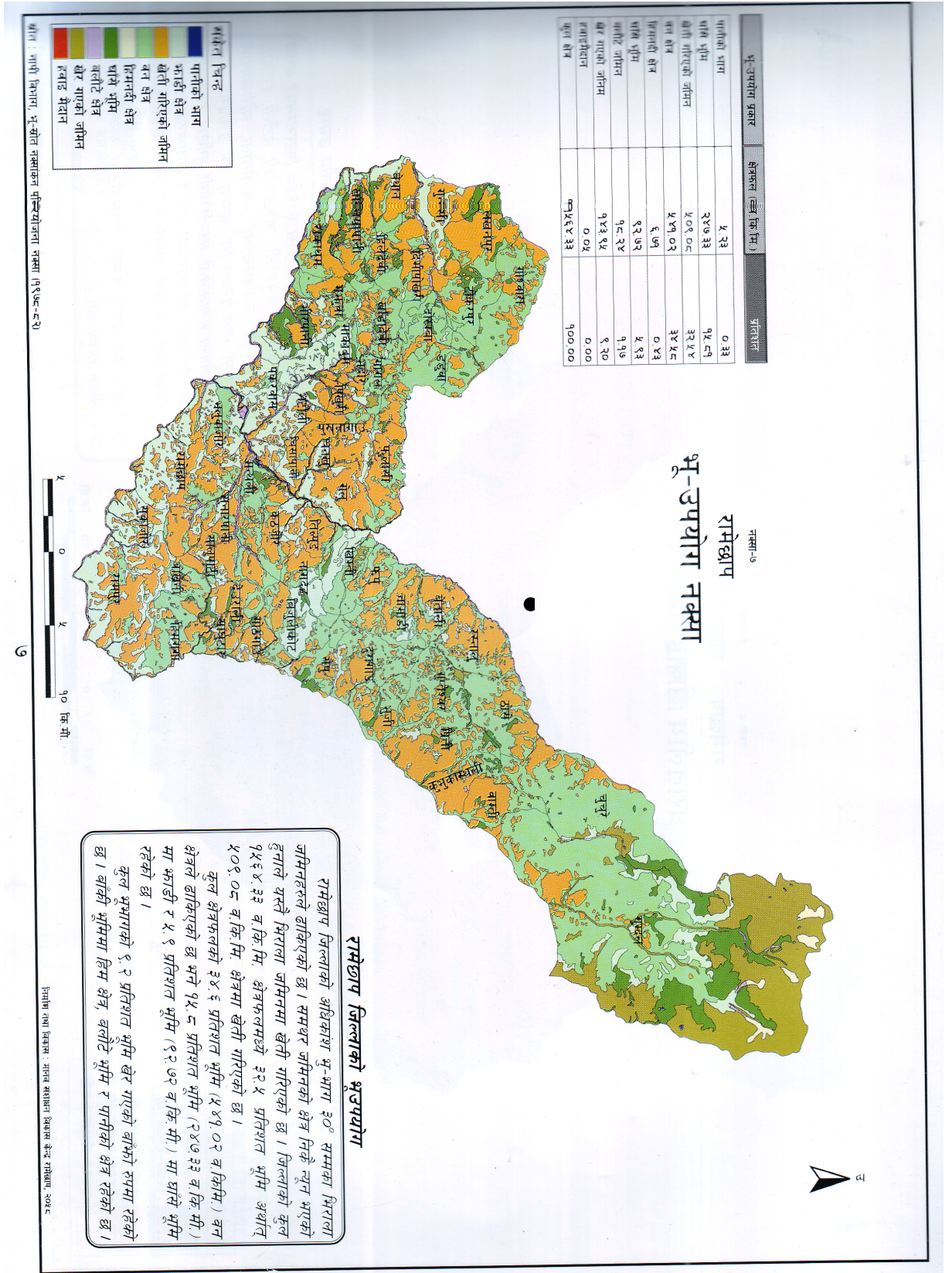

4.2.1 Geographical Condition

Ramechhap district is located between 27°28" to 27°50" north latitude and 85°50' to 86°35' east longitude. Its altitude ranges from 369 m to 6958 m. The political boundary of this district is Dolkha, Kabhre Planchowk and Sindhupalchowk in the west; Dolkha district in the North; Sindhuli district in the South and Solukhumbu, Okhaldhunga in East.

4.2.2 Major Ethnic Composition in Ramechhap District

According to the census, 2058, the total population of the district is 212408 where male occupy 100853 (47.48%) and left are female 111555 (52.52%). The number of total HHs, in Ramechhap district, is 40386 HHs at the average of 5.26 people per house hold. The population growth rate is nearer to national growth rate i.e. 2.21% most of the people lives in rural area, almost 82.56% of the population and the literacy rate of the district is 44.54% (above 6 years), among them male carry the 61.5% and female 27.25% only (2058). Similarly, Tamang (20.34%) is the major ethnic group in the district. Respectively, Brahmin (5.60%), Chhetri (26.31%), Newar (14.06%), Magar (10.90%), Kami (3.02), Damai/Dholi (1.87%), Majhi (2.59%), Sunuwar (4.18%), Sarki (2.63%), Sherpa (2.38%), Gharti (1.40%), Sanyashi (0.81%), Thami (0.76%) and others (3.21%).

4.2.3 Socio-economic Situation

Manthali is the headquarters of district. A majority of the population works in the agriculture sector despite the level of industrialization. Some 47 percent have other occupation. But, the agriculture occupation level is below the national figure 80 percent (DDC

Profile, 2007). Similarly, the literacy rate is which is below the national figure (DDC Profile, 2007).

4.2.4 Land Use

Total area of Ramechhap district consists of 1564.33 sq. kilometer ha and the largest part is covered by forest land. Similarly, agriculture land. The land use of the district is presented in figure 2.

Figure No. 2: Land Use Pattern in Ramechhap District

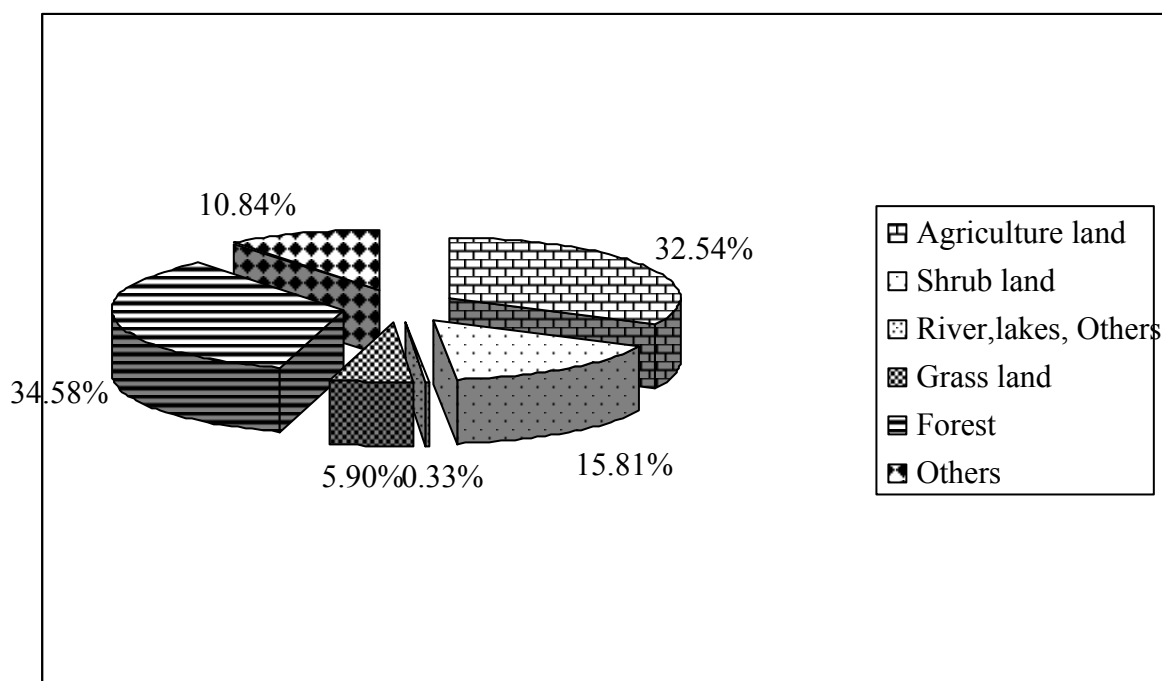

Source: DDC, 2008.

4.2.5 Climate and Soil

Climate varies from tropical, sub-tropical to temperate. Average annual rainfall of the district is 2535 mm and minimum temperature is 36.3 and 16.6 respectively. Its geology is tertiary Siwalik to the North the Mahabharat range to the south. And its soil consists of red soil around black, white, sandy eage or river.

4.2.6 Community Forestry in Ramechhap

The community forestry programme has been a learning programme in the district since 1990, after restoration of democracy through popular people movement. The Nepalese government emphasized people participation in forestry programmes through forest user group. In 1990/1991, there was only one community forest and handed over to user group, but the process was accelerated after the implementation of the forest regulation 1993. Until 2008, 287 community forest user groups have already been registered in the District Forest Office. It covers 23644 ha. forest area, about 32671 household are participating in the community forestry movement through being general user member (DFO, 2009).

Table No. 4.1: Land Holding Pattern in Ramechhap District

S.N.	Landholding pattern	No. of HHs of Total HHs
1	Land less HHs	0.8%
2	0.1 ha to 0.2 ha	13.5%
3	0.2 ha to 1 ha	67.3%
4	1 ha to 2 ha	15.5%
5	2 ha to 5 ha	2.4%
6	5 ha to 10 ha	0.3%
7	above 10 ha	0.2%

Source: DDC, 2007.

4.2.7 Religions Composition of Ramechhap District

The people of this district consist of different ethnic groups believing in different religions. The following table presents the religions composition of Ramechhap district.

Table No. 4.2: Religious Composition of Ramechhap District

S.N.	Religions	No. of people	Percentage
1	Hindu	144010	67.8
2	Buddha	60074	28.3
3	Islam	42	0.019
4	Kirat	4141	2.0
5	Jain	4	0.0018
	Christian	913	0.4
	Sikh	14	0.0065
	Others	3210	1.51
	Total	212408	100.00

Source: CBS, 2001.

4.3 Village Profile

Namadi VDC is located in the electoral constituency no. 1 of the Ramechhap District and the northern side of the district headquarter. It is surrounded by Duragyan VDC to the east Shahare and Chhayama VDC of Dolakha District to the west and Betali Pharpu VDC to the South VDC to the North.

The total population of this VDC is 3981 out of which 1778 are male and 2203 are female. And the total household of this VDC is 839.

Namadi VDC is known as the kitchen garden of Manthali Bazaar. Which is nearly one and half hours far from district headquarter using by bus. The total number of people of this VDC have been engaging on agricultural and livestock. Green vegetables, milk, rice, meat, potato and other food crops have been supplied from this VDC weekly and daily to Khimti, Potato and Manthali Bazaar. The following table shows the number of households having agricultural land, livestock and poultry farm for the VDC.

Table No. 4.3: Household having Agricultural Land, Livestock and Poultry for Namadi VDC

S.N.	Articles	HHs	Percentage
1	Agriculture land	78	9.20
2	Livestock	4	0.47
3	Land and livestock	140	16.59
4	Land and poultry	10	1.14
5	Livestock and poultry	5	0.60
6	Land livestock and poultry	590	70.29
7	Non for all	14	1.68
	Total	839	100

Source: CBS, 2001.

In the Namadi VDC mainly Tamang, Brahmins, Kshetri, Newar, Sunuwar, Kami, Damai, Sarki, Gharti, etc. ethnic groups are living. The following table shows the different groups of castes in the Namadi VDC.

Table No. 4.4: Total Number of Population According to Caste Others Groups

S.N.	Caste	HHs	Percentage
1	Tamang	382	9.60
2	Brahmins Hill	25	0.62
3	Kshetri	2407	60.46
4	Newar	63	1.58
5	Magar	6	0.15
6	Kami	121	3.03
7	Sunuwar	254	6.38
8	Damai/Dholi	92	2.31
9	Gurung	123	3.08
10	Sarki	107	2.68
11	Sherpa	151	3.79
12	Gharti Bhujel	218	5.47
	Total	3949	100.00

Source: CBS, 2001.

Namadi started its educational steps from 2011 B.S. with the establishment of Shree Kamala Devi Primary school which was first government school of Namadi. At present this school is become a Higher secondeary school. And there are 4 other primary schools and one lower secondary school in this VDC which are made by government.

The following table presents the educational status of this VDC.

Table No. 4.5: Population 6 Year of Age and Over by Literacy Status and Sex for VDC

Types	Male	Female	Total	%
Cannot read and write	271	580	851	32.25
Can read only	55	24	79	3
Read and write	901	783	1684	63.81
Not stated	6	29	25	0.95
Total	1227	1412	2639	100.00

Source: CBS, 2001.

The above table 4.5 shows that the large number of females are illiterate in this VDC. And more males are educated than female. The main cause behind it is that the females must engage in household work. So, they can get less opportunities to go to school.

Figure No. 4: Population 6 Year of Age and Over by Literacy Status and Sex for VDC

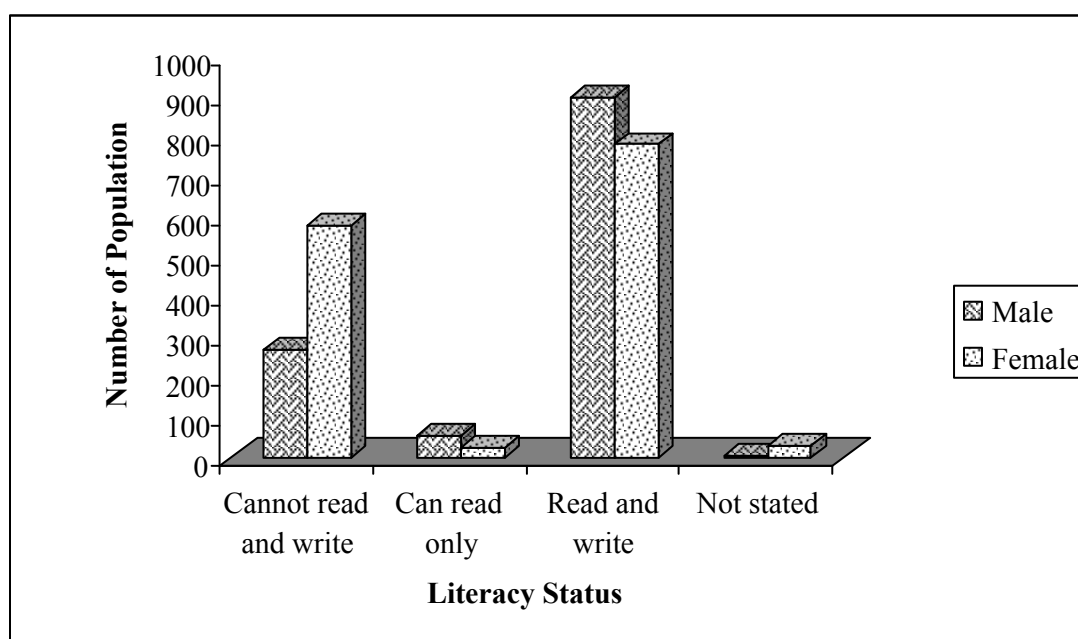

About the total forest area of this VDC 1907.98 hectares are covered by CF. There are 7 CFUGs in this VDC, which include 1333 households.

Sources: Community Forest Division, Department of Forest, Kathmandu, Nepal.

4.4 Description of the Selected CFUGs

Ramite CF lies to the north of Pharpu VDC and west of the Dolkha district Shahare, South of Dolkha VDC and east Namadi Ward No. 8. This CF handed over in 2056 B.S. to the local people. The large part of this forest lies in the Namadi VDC Ward No. 6. The total area of this forest is 264 hectares which is covered by natural forest and plantations.

It is located along with the bank of Khimti river, in this river 60 M.W. Hydropower constructed and running 2057. Now a days the hydropower called Khimti and Hydropower.

Regarding the ethnic composition in CFUG Chhetri (55.35%) is top most population and followed by Sunuwar and Chhetri (31.60%), Sharki (4.43%), Kami (3.47%) and similarly about 6.5% consists of others ethnic groups. Namely, Newar, Magar and Damai. The major positions of CFUG is headed by Chhetri because of the population is high with respect to other. In shortly, Ramite CFUG is known as an active community forest in Namadi VDC. It is also investing major parts of its income in the field of social development and in community as well.

CHAPTER-V

SOCIO-ECONOMIC STATUS OF THE STUDY AREA

This chapter introduces number of HHs, Ethnic composition, family size, sex composition, educational status, occupational composition, distribution of landholding, feeding pattern of livestock, crops production and well being ranking of sampled household and its table, graphs and figure orderly.

5.1 Total Number of Households and Sample

The total number of CFUGs are 7 in the Namadi VDC out of them Ramite CFUG was taken for this case study. There are 310 HHs among them nearly 13% (40) HHs are taken as sample purposively for this study.

5.2 Ethnic Composition of Sampled HHs

Truly, Nepal is a garden of various ethnic groups. Similarly, in the study area (Namadi VDC) where the forest users are consisted of various ethnic backgrounds. The caste and ethnicity play important roles for socio-economic development in Nepalese society. But there has been found a good relationship and participation among all caste groups in the study area. Lower castes also have been involving in every social and developmental work without any discrimination.

The following table show the ethnic composition of the sampled household in CFUGs.

Table No. 5.1: Ethnic Composition of Sampled HHs

S.N.	Caste	HHs	Percentage
1	Chhetri	15	37.5
2	Sunuwar	7	17.5
3	Gharti	3	7.5
4	Kami	5	12.5
5	Damai	3	7.5
6	Newar	4	10.0
7	Sarki	2	5.0
8	Brahmin	1	2.5
	Total	40	100.0

Source: Field Survey, 2010.

The above table 5.1 shows that the major percentage of total HHs are Chhetri, in the study area. After Chhetri caste, the percentage of Sunuwar, Kami and Newar castes comprise second highest in rank.

Figure No. 5: Ethnic Composition of Sampled HHs

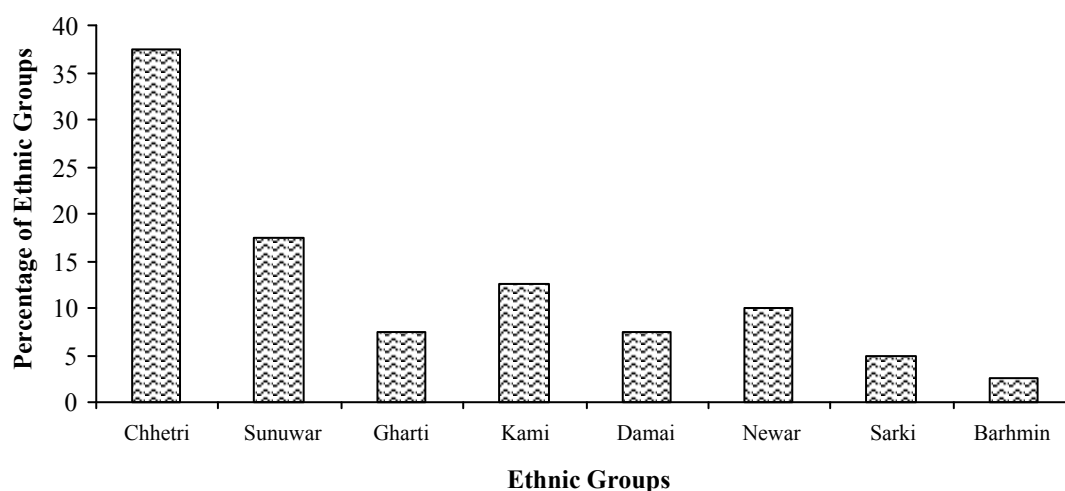

5.3 Family Sizes of Ethnic Groups

The family size affects the economic health, social and educational conditions of the family, from the tables below we can see the family size of various ethnic groups.

Table No. 5.2: The Family Size of Ethnic Groups in Sample HHs

Caste	No. of HHs	Total no. of family members	Average family size
Chhetri	15	68	4.53
Sunuwar	7	31	4.42
Gharti	3	13	4.33
Kami	5	27	5.40
Sharki	3	15	5.33
Newar	4	17	4.25
Damai	2	11	5.50
Brahmin	1	4	4.00
Total	40	187	4.72

Source: Field Survey, 2010.

The above table no. 5.2 shows that the average family size of lower castes as Damai, Kami, Sharki have large number 5.4 and the other castes have smaller family size comparatively. 4.3 and average 4.72 in sample HHs.

5.4 Sex Composition of Sampled HHs

Sex composition is one of the most important demographic features for the planners. Separate data for males and females are important for various types of planning. It will help to know which sector is weaker and

support they can do for uplifting the sex. The balance of sexes affects the social and economic relationship within a community.

The following table shows the sex composition of sampled household.

Table No. 5.3: Sex Composition of Sampled Households

Households	No. of females	Percentage	No. of males	Percentage	Total	Percentage
1	3	3.06	4	4.49	7	3.74
2	2	2.04	2	2.24	4	2.14
3	4	4.08	2	2.24	6	3.21
4	6	6.12	2	2.24	8	4.27
5	1	1.02	2	2.24	3	1.60
6	2	2.04	4	1.12	3	1.60
7	3	3.06	2	2.24	5	2.67
8	3	3.06	3	3.37	6	3.21
9	2	2.04	3	3.37	5	2.67
10	4	4.08	2	2.24	6	3.21
11	1	1.02	3	3.37	4	2.14
12	4	4.08	3	3.37	7	3.74
13	1	1.02	3	3.37	4	2.14
14	1	1.02	4	4.49	5	8.67
15	1	1.02	1	1.12	3	1.06
16	2	2.04	1	1.12	3	1.60
17	1	1.02	3	3.37	4	2.14
18	3	3.06	2	2.24	5	2.67
19	2	2.04	2	2.24	4	2.14
20	2	2.04	3	3.37	5	2.67

21	3	3006	2	2.24	5	2.67
22	4	4.08	1	1.12	5	2.67
23	1	1.02	2	2.24	3	1.60
24	2	2.04	1	1.12	3	1.60
25	3	3.06	4	4.49	7	3.74
26	1	1.02	3	3.37	4	2.14
27	5	5.10	2	2.24	7	3.74
28	3	3.06	2	2.24	5	2.67
29	3	3.06	2	2.24	5	2.67
30	2	2.04	3	3.37	5	2.67
31	4	4.08	1	1.12	5	2.67
32	3	3.06	2	2.24	5	2.67
33	1	1.02	3	3.37	4	2.14
34	2	2.04	2	2.24	4	2.14
35	4	4.087	1	1.12	5	2.67
36	2	2.04	3	3.37	5	2.67
37	1	1.02	2	2.24	3	1.60
38	1	1.02	2	2.24	3	1.60
39	3	3006	1	1.12	4	2.14
40	2	2.04	2	2.24	4	2.14
Total	98	100	89	100	187	100

Sources: Field Survey, 2010.

The above table 5.3 shows that out of total 187 persons, 98 are females and 89 are males. This proves that in this study area, there is little difference between females and males in number.

5.5 Educational Status of Sample Household According to Sex

Education is considered as a human capital and important infrastructure of the development as well. It plays a crucial role in all sectors of all society. In modern age, all the planners agree in the fact that development without participation of local people is almost impossible. for this purpose if all persons of households is educated then participation of them for any development activities are more effective. It can be said that if all persons of households are educated then the society is more conscious about the problem of the community, needs of the community and become able to provide more appropriate solution.

In this study the education status has been classified in to five groups. They are:

- i. Illiterate
- ii. Literate (either form formal on non-formal education)
- iii. Primary
- iv. Secondary
- v. Higher secondary

Illiterate are those who cannot read and write. Literate represent those persons who can read or write either from formal or non-formal education. Primary education means the academic education up to class five. secondary in known as the academic education up to S.L.C. and higher secondary education in that the academic education above S.L.C Level.

The education status can be seen on the following tables in sampled households.

Table No. 5.4 : Educational Status of Sampled Households

Level	No.of females	Percentage	No.of Males	Percentage	Total	Percentage
Illiterate	34	34.69	6	6.74	40	21.39
Literate	16	16.32	20	22.47	36	19.25
Primary	21	21.42	23	25.84	44	23.52
Secondary	18	18.36	25	28.08	43	22.99
Higher	9	9.18	15	16.85	24	12.83
Total	98	100	89	100	187	100

Source: Field Survey, 2010.

The above table 5.4 shows that out of 187 Population of total, 21.39% persons are illiterate and 19.25% persons can a little read write and only a few persons have got higher education in the sampled HHS.

Figure No. 6: Educational status of sampled Households

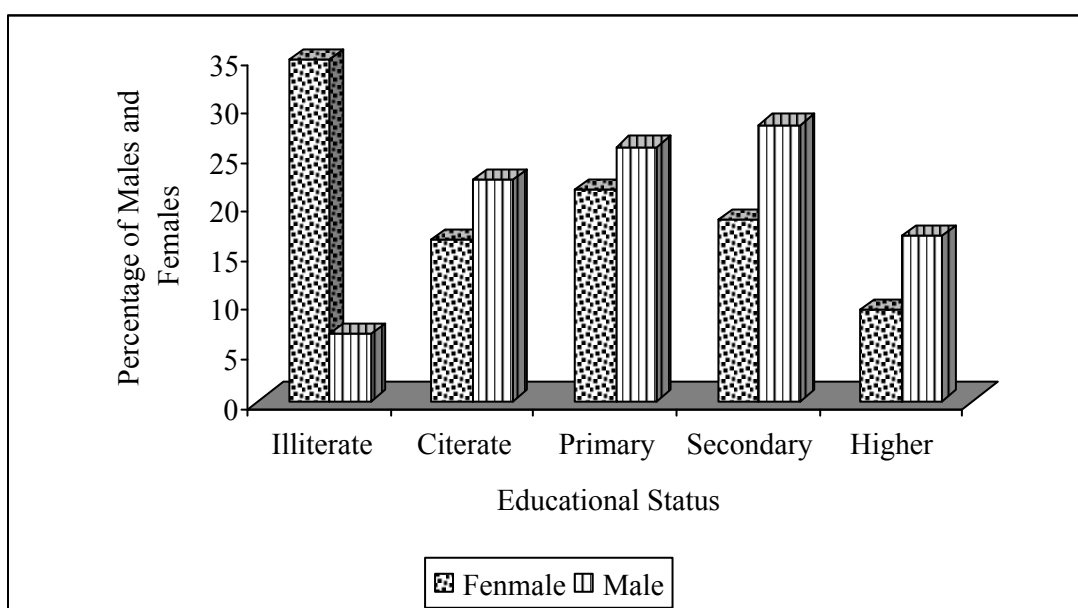

Source: Field Survey, 2010.

Comparing male and female, the larger percent of females are found illiterate and only a small percent of females can a little read and write.

5.6 Occupational composition of sampled Households

Agriculture is main occupation in Nepal. This trend can be seen in the study area also and livestock is an additional occupation of this area. The main sources of income are agriculture and live stock. Moreover, some household are engaging in non-agricultural occupation such a service, business, wage labour and traditional (caste-wise) profession. The tables below show the occupational composition of sampled HHS.

Table No. 5.5: Occupational Composition of Sample Households

Occupation	No. of Households	Percentage
Agriculture and live Stock	19	47.5
Service	6	15
Business	3	7.5
Wage labour	9	27.5
Traditional profession	3	7.5
Total	40	100

Sources: Field Survey, 2010.

The above table 5.5 shows that nearly 48% of the total sampled households are exercising in agriculture and livestock occupations other households are engaged in other professions like service, business, wage labour, etc.

Figure No. 7 : Occupational Composition of Sample Households

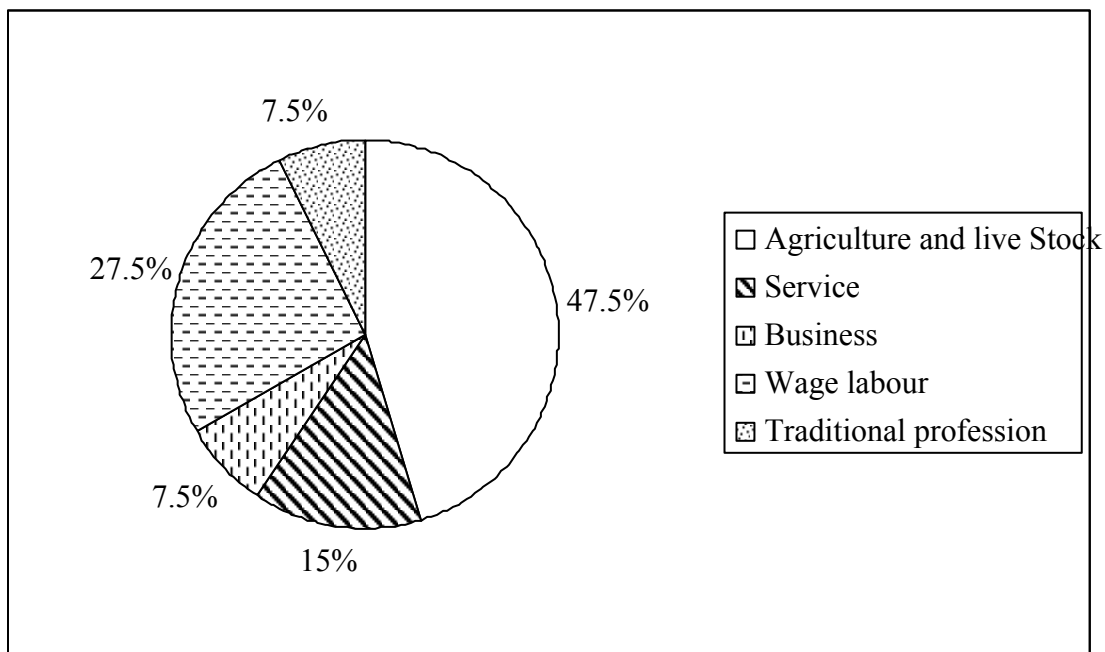

Sources: Field Survey, 2010.

5.7 Distribution of Livestock Holding in the Sampled Households

Livestock is one of the important occupations of Nepalese people for getting milk, meat, manure, ploughing ghee, eggs etc. Livestock is also a means of liquid assets which can easily be converted in to cash during crisis. Livestock play a multi-functional role in Nepal's farming system. They provide milk, meat, and draught power for tilling the land and manure for the maintenance of sails." (Streak 1998).

The following tables show the total number of livestock holding at present in the sampled households.

Table No. 5.6: Distribution Livestock Holding of Sample Households

Types of Animals	Average No. of perttis live stock	Percentage
Buffalo	1.00	6.82
Cow /ox	1.85	12.62
Goat	3.55	24.23
Chicken	6.80	46.41
pig	1.54	9.89
Total	14.65	100

Sources: Field Survey, 2010.

The above table 5.6 shows that out of total average 14.65 livestock, 46.41% are chicken, after it the highest percentage of livestock is goat which is 24.23% After then the percentages of cow pig and buffaloes followed.

5.8 Feeding Pattern of Livestock in Sampled HHs

Most of the people of the sampled households keep their livestock by stall-feeding. No one keeps their lives for grazing. So, forest products have not been destroyed by animals. It is a hard and fast rule making by all users not to graze their animals in the CF area, If it is found the person who grazes the animals he must pay fine. Therefore, all household usually collect forage, grass and edible weeds from the forests and form lands to feed their livestock.

5.9 Distribution of Land Holding in Sampled Households

Land holding is one of the most important determinants of the income and food sufficiency. More than 45% households have not Khet (irrigated land). So all of them use to spend their income for purchasing rice.

The following tables show the average land holding pattern of sampled household in the CFUGs.

Table No. 5.7: Distribution of landholding pattern in Sample Households

Land size (In Ropani)	No of Households	Percentage
Land less	-	-
Less than 5	9	22.5
5-10	11	27.5
10-20	13	32.5
20	7	17.5
Total	40	100

Sources: Field Survey, 2010.

Figure No. 8: Distribution of Land Holding Pattern

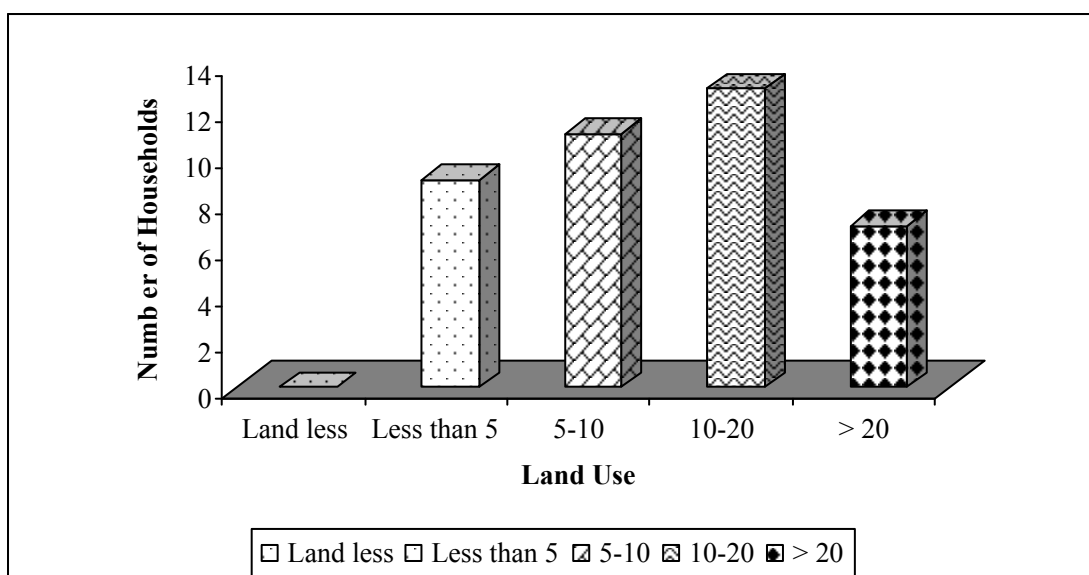

Sources: Field Survey, 2010.

The above table 5.7 and figure no. 6 show that the majority of households have been holding in between 10 to 20 rapani land, few (only 7) households are getting more then 20 ropani land

5.10 Crops Production of Sample Households

Differed kinds of crops are the main source of food for villagers. Paddy, maize, millet are the main crops production of the study area. So, mainly these 3 crops are calculated.

The average crops production are in the following tables.

Table No. 5.8: Distribution of crops production in Sampled Households

Crops production (In Muri)	No. of households	Percentage
Less than 5	13	32.5
5-10	9	22.5
10-20	6	15
20-30	8	20
30	4	10
Total	40	100

Sources: Field Survey, 2010.

Note;- 1 Muri = nearly 50kg

Figure No. 9: Distribution of Crops Production in Sampled Households

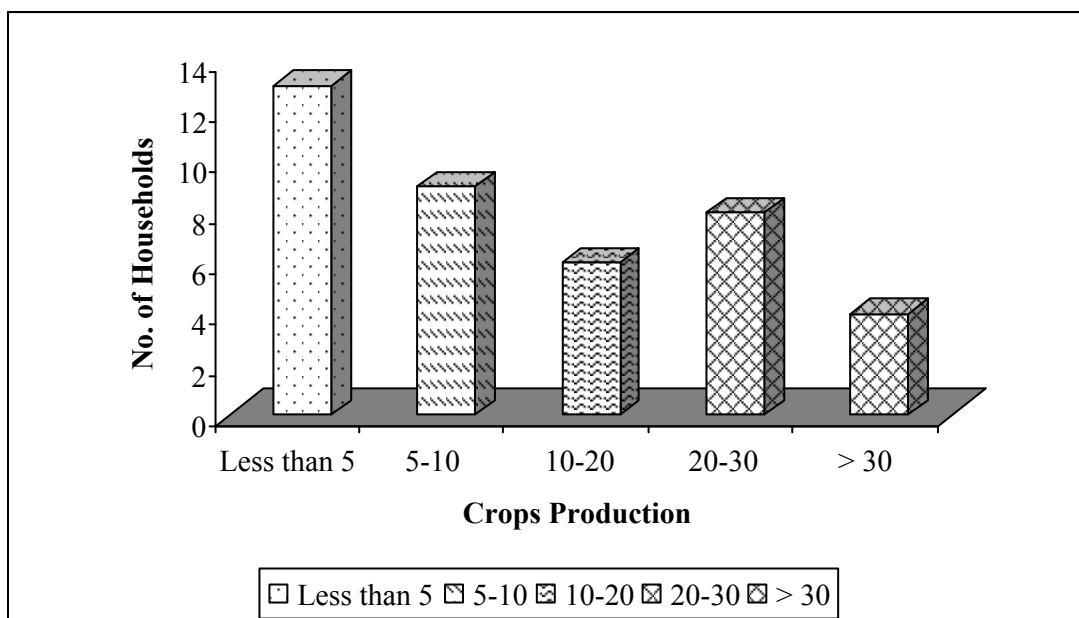

According to above table 5.8 and figure no. 9, show that more than 50% households have only up to 10 muri crops Production from their own land in a year . so, this clearly shows that there is food problem among those households.

5.11 Well-being Ranking of Sampled Household

To introduce the economic status of user's households, 'well-being ranking, the tool of PRA has been applied. This has been done with the help of DFO, RP and NGO on the basis of landholding size, family size, food sufficiency from their own land, off farm income such as remittances from pension, services in different organizations.

The following tables show the well-being ranking of sampled households in the basis of food sufficiency.

Table 5.9: Well-being Ranking of Sampled Households

Particulars	No. of HHs	Percentage
Food sufficient below 3 months	4	10
Food sufficient upto 3 months	13	32.5
Food sufficient upto 6 months	7	17.5
Food sufficient upto 9 months	5	12.5
Food sufficient upto 12 months +	11	27.5
Total	40	100.0

Sources: Field Survey, 2010.

Figure No. 10: Well-being Ranking of Sampled Households

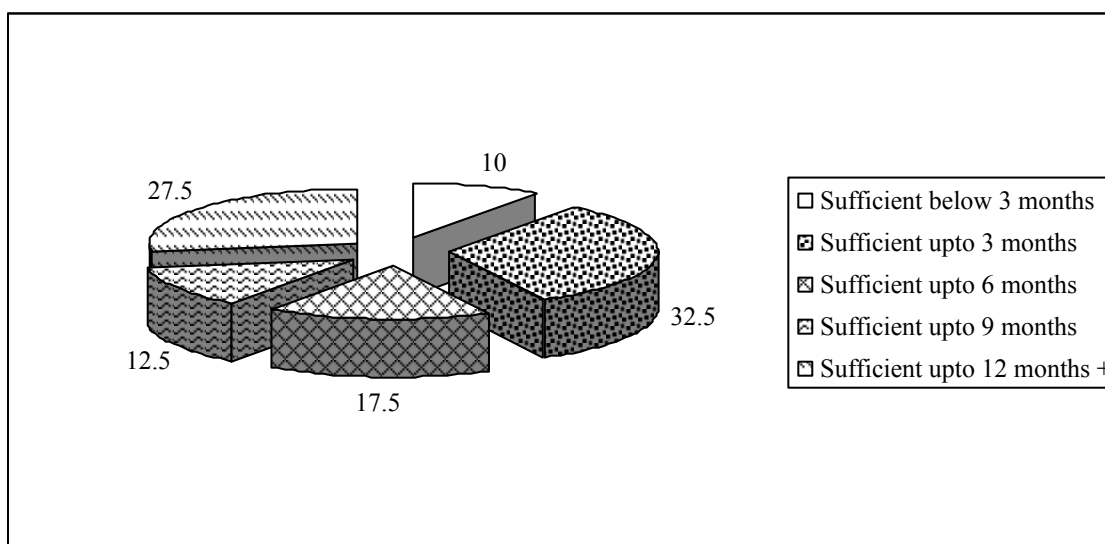

According to the above table 5.9 and figure No. 10 show that 11 households (27.5%) can solve their hand to mouth problem for entire year from their own food production and 29 households usually suffer from 'hand to mouth' existence. So, they have to buy food from their sources of earnings to meet their food deficiency problem.

CHAPTER - VI

INCOME GENERATING ACTIVITIES OF CFUGS

6.1 Introduction

Income generating activities have been initiated by the supporting of PAF grants. If there is potentiality of cash cropping (i.e. NTFs such as Amliso, turmeric, etc.) in the CF area, CFUGS can farm according to their own wishes. The main purpose of these activities is to raise additional income/employment opportunities to the poor as well as to increase the fund of CFUG. By the help of DFO, this funding support has been provided to the CFUGs in Ramechhap district.

According to the action plan of DFO there are 156 CFUGS involving in IGAs from FY 2000 to FY 2007 by the support of projects' grants. The DFO has provided Rs. 2,95,240 amount of project's grant to all the CFUGs. And 137 CFUGs have been performing IGAs from their own funds.

6.2 Income Generating Activities of Ramite CFUG

Mainly, the Ramite CFUG has been performing two types of inter-crop farming in the CFUG's area. They are as follows:

6.2.1 Amliso (Broom Grass) Farming

The botanical name of Amliso is *Amomum subulatum*. In the rural area, it can be used for two purposes. One purpose is to use Amliso for making broomstick. And another purpose is to use Amliso as a kind of fodder for livestock. It is ever green grass in winter season also. So, in winter it is very much useful for green grass. Therefore, people use to

plant this for fulfilling the needs of green grass and broomsticks. A piece of broomstick can be sold at Rs.15 by the people of study area. In this way two types of benefits have been achieved from this farming.

In Ramite CFUG, there have been planted 4000 pieces of seedlings on 20 ropanies land. For purchasing seedlings DFO has provided Rs. 4000 amount from the grant of NUKCFP in FY 2000. Now, the Amliso farming at Ramite started to produce Amliso. The general assembly of Ramite CFUG evaluates the wholesale value of total products of Amliso farming. At the time of the field survey of this dissertation research, the amount of tangible income collected from Amliso is Rs.1500; which is deposited in the fund of Ramite CFUG. The intangible benefits from Amliso are their use as fodder.

This Ramite CFUG has been making a plan for planting additional 3000 pieces of seedlings in FY 2000. To purchase these seedlings, CFP provided Rs.3000 through DFO. Hopefully, this implementation of this plan will benefit to households and CFUG of Ramite also.

6.2.2 Turmeric Farming

Turmeric is one of the inter-croppings of Ramite CFUG. This farming has been started by the participation of only 10 sampled HHs. Nearly, 5 ropanis land have been cultivated by these HHs very actively. In the starting period the seeds of turmeric are purchased from the amount of CFUG's fund. There are planted 27 kgs of seeds. Ramite CFUG has generated a substantial amount of income from this turmeric farming. The total production of turmeric in the FY 2006/07 is between 100 to 150 kgs. They deposited 10 percent of the total income to their fund. In addition 25 kg. of turmeric seeds are saved to cultivate again in the next season. The users of 8HHs have got good benefit from the farming of turmeric in the

CFUG. The remaining nearly 75/125 kgs., they divided equally for their own consumption.

6.2.3 Other Sources of Income for CFUG

1. Green-Ground Grass

This is a kind of source for earning income to the CFUG. When there is restriction of grazing for animal this grass has been grown up.

The CFUG area use to open for collecting grass from May to September. During this time the users use to collect 3-4 bhari of grass per day for their live stocks. Purji system (in which the normal price is paid so that the forest authority gives permission) has been applied for distributing grass to all HHs. For taking Purji Rs.10 is determined by committee's members. Then after, anyone of the users can carry out the grass during opening time. In FY 2007, there has been collected Rs.170 in the CFUG's fund.

2. Dry Grass (Khar)

This is a kind of grass specially used for making the roof of houses particularly, the users whose houses had not been made from tile or tin. The price of the production is determined by the general assembly of FUG. Simply, normal price is determined for the user of own FUG. Nearly 12 HHS are benefited from this production and collected 1760 rupees to the fund in FY 2007.

3. Fuel Wood

In Ramite CFUG fuel wood has been distributed equally to all HHS, Nearly one months of February the forest area is opened for cutting fuel wood. The members of committee distribute by measuring the fuel

wood with the help of Dori (rope of 4 meters.) All HHs receive 10 dories. In the FY 2007, Rs. 2090 have been collected in the fund.

4. Timber

This is also a source of income for the CFUG. If the users of this CF asked for wood for making their houses, they pay some amount to the CFUG. This also provides to users according to CFUG's rule.

In the FY 2007, there has been collected 2150 rupees for wood.

5. Fines and Penalties

In the case study, it is found that the user who break the rule of group and does not come to the work of forest development and management must be fixed.

Grazing animals are not allowed in CF area. If any body grazes their animals inside the forest, he will be fined. The rate of fine is Rs.100 per animal at first, Rs.200 in next chance and Rs.500 at third time respectively assembly of CFUG.

Similarly, cutting trees without permission of UGC is supposed to be illegal in this CF. In any body of FUG as well as outsides does this type of illegal work he must accept the penalty levied by the decision of UGC.

On the other side, the person who does not attend the work of forest development and management also will be fined. The general assembly of CFUG fixed Rs.100 for one day's fine.

In FY 2007, Rs.1550 amount collected to the CFUG's fund as fine.

6. Entry Fee

The person who is the inhabitant of Ramite-6 and interested to enter into the CFUG must pay some amount in the form of entry fee. This fee is collected according to the rule of CFUG.

In the FY 2007, there has been collected 1720 rupees in the funds.

7. Livestock

This is one of the most IGAs of FUG. CFUG's fund has been mobilized from this activities. According to committee's decision 10% rate of interest is determined for providing loan. Nearly, 40 HHs have been taken loans for buying pig (s/he), goat (she), buffalo(she) and cow/ox form selling the production of animals half of them, returned their loan and interest to the fund.

6.3 Sources of Income for Sampled Households

The main sources of income are agriculture and livestock for the sample households. From agriculture the some sampled HHs of both CFUGs we to cell cereals, vegetables etc. And some sampled HHs sell livestock's production for earning income. Some of other households use to sell their labour for earning income.

The main sources of income for sample HHs and the average prices of each item are shown as follow.

	Price (in Rs.)
1. Cereals	
Rice	35 per kg
Maize	22 per kg
Millet	20 per kg
Wheat	20 per kg
2. Vegetables	
Items	Price (in Rs.)
Potato	22 per kg
Cabbage	20 per kg
Cauliflower	25 per kg
Bean	18 per kg
Green vegetables(Gralic, onion, radish etc)	25 per kg
Turmeric	60 pre kg
Ginger	25 per kg
3. Livestock production	
Items	Price (in Rs.)
Milk	30 per liter
Ghee	235 per kg
Yogurt	30 per kg
Chicken	200 per kg
Baff	100 per kg
Pork	80 per kg
Mutton	300 pre kg
4. Others	
Items	Price (in Rs.)
Fuel wood	100 per Bhari 45 kg nearly
Wage labor	70 per day
Broom stick	15 per piece

Sources: Field Survey, 2010

The above mentioned items are the main sources of earning for sampled HHs in the study area. The sample households as well as other HHs have been exercising with above activities for earning income and to meet their hand to mouth existence.

6.4 Annual Income of the Sampled Household

The major sources of income for the people in the study area are agriculture and livestock for sampled households. But respondents feel uneasy to reveal their cash income. They do not keep any record of their income and expenditure. So it is very difficult to know about accurate annual cash income. The following of the households from various sources in 2002 and in 2009.

Table 6.1

Average Annual Income of Samples HHs in Ramite CFUG.

Annual Income (In Rupee)	No. of HHs in 2002	No. of HHs in 2009
2000-4000	15	0
4001-8000	12	6
8001-12000	6	11
12001-20000	5	16
20000	2	7
Total	40	40

Sources: Field Survey, 2010.

The table 6.4 shows that there were 15 households who have annual income between 2000-4000 in 2002 and no one households a annual income in 2009. 7 HHs have income greater than Rs.20000 in 2009. Majority of the households falls in the group of Rs.12000 to 20000 in 2009 where as in 2002 majority of to house holds fall in the group of having income less than Rs.8000.

CHAPTER VII

SUMMARY, CONCLUSION AND RECOMENDATONS

This chapter deals the major findings, conclusion and recommendation for the further study.

8.1 Summary

- It is found in the study area that the Ramite CFUG has done a seminar of two days for making its a long term (10 years) vision. The main vision of this CFUG is to reduce poverty by improving livelihood of people through forestry programme. By the seminar the users have also known that without the development of 5 capital i.e. natural capital (knowledge, skill, awareness), physical capital(schools, roads, financial capital (income, earnings), social capital (customs, values and institution) at the same ratio these is no possibility to increase people's livelihoods.
- The forest condition is found good on the CFUGs. Plants are growing day by day. The greenery of forest gives an attractive scene from which people can take a kind of pleasure.
- The people, particularly, the major percentage of women are found illiterate in to study area. Due to the lack of education, the hesitate to involve in the users committees. But now the environment is changing women participation is also little satisfactory on assembly, seminar and different programmes which was not in the past days.

- The co-operation and co-ordination among the users have better. People's participation is active on every programme of forest. But some users are taking negligence for the forestry programme.
- Fund mobilization for IGAs is a model work of this CFUG. Paying interest at the rate for different types of IGAs from CFUGs fund.
- In Ramite CFUG the fuel wood has been provided equitably to the users on the basis of family size.
- NTFPs farming is a popular IGA of CFUGs seeing this popular work users of other neighboring CFUGS come to visit as a study Tour.
- NGOs, DFO, Projects are providing different types of training, study tour which can increase the users knowledge.
- The CFP is sustainable and is very significant to meet the needs of the villagers. This programme is quite effective in the feeling of people.
- Labour of the people is going to non profit activities and use to agriculture as a mass production and create a market and find out for grate income.
- The production system must be change to one production, one quality, one skilled one grant, one labour one but money market to sold the product.

8.2 Conclusion

The study concludes that the community forestry programme is very successful to improve forest condition which has been degrading day by day. FUG plays a vital role for the preservation of forest and management to provide forest products for the villagers.

The funding support given by projects for IGA to CFUGs have encouraged them to operate such activities. These activities help users to increase the size of fund.

Further more, this shows that the CFUGs have learnt new ideas of getting additional profit and income employment opportunities from their CF. They are using the waste land and improving the bio-diversity. So, the demand for IGAs by the people has been increasing day by day.

Although it has some problems but these are minor, these will be solved day by day with the help of different sectors like community, NGO, INGO, DFO, other project, etc. Lastly, CFUG start to involve poor, women and disadvantaged groups of people in the activities according to their interest and encourage them to take part in decision making processes. All the above facts show a prosperous future of CFP.

8.3 Recommendations

On the basis of findings of the study, the following points are recommended which may be useful for the programme.

- The technical knowledge, related to different types of NTFP management should be developed through training and field based practiced for FUGS, DFO staff and other service provides.
- Knowledge and skill derived from training and study tour be transferred with each other among to users.

- The position of women is backward in our society in all walks of life. In daily life they involve in different activities such as cooking food, collecting fire wood, cutting fodder for livestock, etc which are not counted as income generating work. So, the activities direct related to women should be carried out. So, it could encourage them to involve different kinds of programme related to CF.
- Participation of women, poor and disadvantaged groups in decision making should be encouraged through adequate representative in users committee.
- Market should be managed to NTFPS these should not be sold in broker's hands by the users, taking low price.
- NGO, Government and Local people should still be more active future development of CFP.
- Measures should be taken to the illiteracy through formal and non formal education such as adult literacy classes, child education by coordinating with government, NGOs and INGOs.

CHAPTER-I

INTRODUCTION

1.1 Background of the Study

Nepal is land-locked country which covers 1,47,181 sq.km. area of world. It is a country of rural areas in which more than 85% people are living in rural areas. It is one of the least development country of world. But it is very rich in term of forest resources and bio-diversity. The forest resource has made a significant contribution to economic and social development of the country.

Natural resources refer to any portion of the natural environment such as atmosphere, water, soil, forest, wildlife, land, minerals and environment asset. It is a relative term as it may vary different from society to society in its importance. On its broad classification come the renewable and non-renewable natural resources. The abiotic resources as natural gas, petroleum, coal, mines and metals come under the non-renewable resources while mostly biotic resources as farming, water, forest and sun are renewable natural resources.

Forest is one of the important natural resources for raising socio-economic status of the local people. Forest directly fulfills forest related substitutions need of women, poor and backward people. Forest has been providing inputs for agriculture, livestock and it supplies medicinal herbs,

timber and non timber forest products. It also conserves watershed, improves the condition of the soil and provides recreation for tourists through forest based eco-tourism national park and wildlife reserves. Similarly, it is providing a habitat for flora and fauna. It also providing raw materials for forest related industries.

Once the forest know as the chief wealth of the country, which proves the popularly known proverb; 'Hario Ban Nepal Ko Dhan: Forest alone contributes 10% to total national GDP, live stock get 40% of total fodder from forest fallage (Ban Ko Jankari, 2005); Fuel, wood contributes about 76% of the total energy sources used in the country, which also comes from forest. Also much of the agricultural system are directly based on the forest (NPC, 1998).

In the context of Nepal, forest cover was more the 45% of total area of the country in 1964. This has been reduced to 29% by 1998 (NPC, 1998). The population of Nepal has grown during last decade of the rate of 2.2% per year. Where as forest has been degraded at on annual rate of 1.7% per year. This has been creating many problems to the mankind and the environment.

In Nepal, community forest programme was started in 1979. Although it is a new programme it has developed dramatically in the last decade. Large areas of forest cover area being brought under community forest management. This is one of the successful programmes and is based on the concept of peoples participation. The main focus of this programmes is to involve local community in forest management.

Community forest comprises the most focused area of forest management in Nepal, especially in the hill districts. Community, forests encompass those parts of 'National forest' that have been 'handed over' to a community forest user group (CFUG). The CFUG is entitled to develop, conserve, use and manage the forest and sell and distribute forest products by independently fixing the price.

During, the past 29 years of community forest implementation, about 1.2 million hectares of National forest has been handed over to more than 14,000 local community forest user groups involving 1.6 million households. The user groups cover about 35 percent (%) of the country's total population. The achievement of the community forestry can be seen in terms of better forest condition, better mobilization and income generation for rural development and institutional building at grass-root level (Kanel, 2006).

1.2 Statement of the Problem

Due to high growth rate of population the forest resources has been declining day by day. The rapid growth of population exerts pressure on the available farm land as it will not be sufficient to feed the growing peoples. So, the people, mainly the poor start cultivating the marginal land by clearing the forest resources declining area.

In 1964, about 45% of the total area was covered by forest. This area declined to 43 percent in 1979 and in 1986 it still declined to 37.4 percent, recent survey show that the forest sector covers only 29 percent of the total land area of the country in 1998 (NPC, 1998). This fact clearly shows that the forest resources has been exploited regularly. Government

introduced several hard rules for forest management but could not control. It is realized that without the active participation once-operation of the local people, the forest conservation and utilization policy will not be effective and sustainable. Therefore, to tackle these problem/community forestry was introduced.

Now, there is a need for reviewing and examining the effectiveness of community forest and find out solution for its further improvement in its mode of operation. The present study attempts to explore the existing knowledge and working model at community forest of the study area.

The policy of community forestry is very good in rhetorical perspective but in reality higher class user groups are taking more benefit than lower class user groups. The main problem is policy gap between rich and poor user groups.

1.3 Objectives of the Study

Generally, this study has focused 'Income Generating Activities of Forest User Group' of the study area. The specific objectives have been set as follows:

3. To analyze the socio-economic status of the forest user group.
4. To assess the income generating activities of forest user groups.

1.4 Importance of the Study

Forest resource is the main parts of natural resources many more things is being provided by forest to the environment. Such as, ecology balance, fodder, leaf, liter, water sources etc. It covers the area of 29 percent of the country.

Community forestry programme is very effective in a rural agrarian country like Nepal. It makes people feel that the forest belongs to them and they took after in carefully. Different types of income generating activities have been started by users to improve their livelihoods.

There has been so many researches and studies regarding community forestry programme but in the hilly region of Nepal specially Ramite Kati Community Forest Namadi VDC of Ramechhap District, there have not been any satisfactory studies. In other words, it is a virgin area from the view points of research.

Therefore, the present study is focused on virgin area to explore something inside the community forestry with field level data. It is hoped that the outcome of the study will be helpful to introduce different types of benefits derived from community forest programme.

1.5 Limitations of the Study

Followings are the limitations of this study

1. This present study has focused on only Ramite Community forestry Namadi VDC Ramechhap district. Therefore, the findings of the study may not give the whole picture of other groups.
2. The study has conducted within the given time and financial limitation.
3. The study has focused on income aspect of the households only.
4. Simple statistical tools are used to analyze the data obtained.

1.6 Organization of the Study

The study encompasses seven chapters. The first chapter introduces the background: Introduction, statement of problem, objectives, importance, limitation and organization of the study. The second chapter describes the review of literature. The third chapter deals with the research methodology of the study. The fourth chapter introduces the introduction to the study area. The fifth chapter deals with the socio-economic status of the study area. The sixth chapter describes the income generating activities of CFUGs in the study area. And the last chapter describes major findings, conclusion and recommendations. At the end bibliography is presented

CHAPTER-II

REVIEW OF LITERATURE

There are many scholars and researchers who have devoted their time studying forestry issues in Nepal. Their efforts to find out the forestry problems and solutions are considered valuable contributions. However, here only some literatures of scholars and researchers have been reviewed in order to know about the existing status of community forestry in Nepal.

"Hariyo Ban, Nepal Ko Dhan" i.e. Green forest is Nepal's wealth" is an old slogan showing people's perceptions to Nepal's forest resource. It proves that the forest is one of the most important resources of Nepal. But now a days, the Nepalese forests are being destroyed at a speed which is hard to imagine.

In the past, the population was less and people lived in close harmony with nature and gave top priority to the conservation of forest resource. In those days forests were looked upon as sources of subsistence and vital source for maintaining life supporting system. There was strict social control on the cutting of trees in the past. So the forest was remained in a good condition. In the Lichhavi period even to enter the forest, king's permission was needed. During Ram Shah's regime even dry leaves were charged.

According to Fisher and Gilmour (1991), the deforestation in Nepal started form eighteen Century. After the unification of Nepal, the government took little interest in forest management. Land policy in the hills was designed to encourage the conversion of land from forest to agriculture in order to increase the tax base. People were awarded by the

government with Birta lands if they undertook to reclaim virgin forest lands and bring it under cultivation. Such lands were granted tax exemption for some period as an incentive.

Regmi (1978) has concluded that the Ranas also did not change their view about forest because land was still the principle economic resource of the nation. They encouraged and pushed Jamindars or Birtawals to the terai and encouraged as much as possible to be brought into cultivation. About one third of the total forest and cultivated lands were under Birta tenure and 75% belonged to the members of the Rana family. During in this period there was British rulers in India. The Rana rulers initiated a number of measures to maximize revenue from the timber export trade with India. In this way trees were indiscriminately felled to supply timber for buildings ships and railway lines and to provide fuel for the ships and trains.

Bajracharya (1983) mentioned that the planning and control of forests by the government made people to think negatively towards forest. Heavy deforestation took place as the villagers felt that their forests have been taken away by the government. The villagers have a strong incentive to destroy the forest so that the land could be claimed as private property .

Community forestry has involved to establish a suitable management of forests at local level. Rural communities have had significant achievements in meeting their forestry needs, generating and utilizing funds for community welfare, and conserving the forest as well. However, the management of community forestry will be at risk if the existing institutional arrangements within the user groups are not

improved and user groups do not strive to attain a suitable security for subsistence before migrated market economy.

Community forestry in Nepal has now found a certain direction through the support of forestry policy, legislation, departmental guidelines and extension oriented forestry, staff, passing over different obstacles and difficulties (Singh, 1998).

Community forest is a partnership programme between government and community organization in which government staff plays roles as facilitation and catalyst to identify real user groups to prepare operational plan of forest and constitutions of group and in implementation of community forestry activities. Whereas the community (user group) is responsible to manage, protect and utilize the forest in the sustainable basis.

A book prepared by Kafle (2000) pointed out that the Department of Forest has difficult task to protect effectively manage and sustainable use of the nation's forest resources. Most forest district offices had inadequate staff. So, it was not possible for the staff to protect the forest. Therefore to solve the problems new forest management acts were introduced.

Between 1957 and 1978 several laws and acts were passed defining the government authority over the forest and regulating the use of resources. Forest Act 1961 was first comprehensive forest legislation in the history of Nepal. It was an attempt to Institute the better management of the forest. Due to the political change in 1960. Nepal introduced a Panchayat system of government. The forest Act of 1961 which followed this change made provision for land to be made available for small private forest plots and introduced the idea of transferring government land for the use of Panchayat (Mahat et al. 1987).

Government Introduced several rules for forest management but could not be controlled and managed which resulted a high rate of deforestation by the large private owners: Most people had, come to believe that government forest belonged to nobody. They still needed forests products and damaged it continuously. On other hand the government did not realize the basic forestry needs of rural people and tried to keep them out of the forests, but there was no alternative for the people except illegal collection of forest products. As a result between 1963 and 1979, 500000 'hectars of forest land were cleared and about one million hectars of forest was regarded in terai and Dun valley (Bajracharya, 1993).

The first social or community forestry is believed to have originated in Gujarat of India and was conceived as an approach to first development and first conservation (Kayastha, 1991). In India attempts to engage communities in tree growing data back to the 1950s through few results were obtained from early efforts.

National Forestry Plan was formulated in 1976 by a conference held in Kathmandu in 1975 to consider various issues relation to the mal management of forest in Nepal. It was attended by District Forest Officer- from throughout the country and senior members of Forest Department and Ministry. It was remarkable that the planned three days meeting extended to 23 days because of the great interest. That was generated and the desire to make a strong statement on the need to address the deteriorating condition of the country's forests (Mahat, et al. 1987).

The master plan for the forestry sector further boost the community forestry approach by stressing the need for management plans to be

developed at FUG level and identified all the forest development staff as extension agents Nepal's total forest area is 5.46 million hectares which are about 37 percent of the total area. Out of the total forest area, 62 percent of the forest is proposed as potential community forests.

Upreti (2000) stated that the community forestry have positive impacts on gender, equity, poverty, biodiversity and forest management which are significantly contributing to social change. The poverty reduction aspect is relatively weak as compared to the achievement made on gender and equity. The level of awareness is increased where by quantity and quality of participation of users poor, women, untouchables etc. is improved.

It is possible from community forestry to reduced poverty by securing resources for the poor, increasing the availability of resources and providing potential for income generating activities. Community forestry contributes to improve people's livelihood. It has contributed significant in building social capital.

The conference was followed by tile formation of a working group charged with the tasks of formulating a plan to guide- the future development of the forestry in Nepal. This culminated in the publishing of National Forestry Plan in 1976. National Forestry Plan (NFP) classified national forest in to four different categories according to use i.e.

Panchayati Forest (PF)

Panchayat Protected Forest (PPF)

Religious Forest (PF)land

Leasehold Forest (LF)

The promulgation of the NFP provided a policy base for instating forestry development.

The government forest to Panchayati Forest or Panchayat Protected Forest followed by the approval of management plan by the District Forest Officers. The rules and regulations were initiated which would govern the handing over of limited areas of government forest land to the control of the Panchayats. Therefore, formal recognition of the rights of villagers to manage their own forest resources with technical assistance is being provided by the forest department.

According to Karmacharya (1987) only 36,376 hector was handed over to Panchayati Forest or Panchayat Protected forest in 29 districts. Regmi, (1984) found that the control of community forests to be managed by local people were further strengthened by the provision of the decentralization act 1982. The community forests were passed to the users group as Panchayati Forest (PF) and Panchayat Protected Forest (PPF). Truly, Speaking the National Forestry Act 1976 played a key role in introducing community forestry and moreover the decentralization act 1981 became the next pillar for the development of community forestry.

The Master Plan for the Forestry Development was formulated in 1987-88. This plan touched all the forestry related issues and activities and emphasized on community forestry. Now community forestry has been the main forestry sector policy of government of Nepal.

Rana (1996) in his case study concludes that the community forestry had direct impact in the day to day lives of people of the villagers. The level of income has been effected positively. Community Forestry programme has been a vital necessity in providing the users with

forest product, Fodder and firewood supply has increased. He recommended in his study that the NGOs, INGOs and government sectors must devote further to expand community forestry in every villagers in the hills of Nepal.

Aryal (2000) found in his study that the community forestry in village is now the main source of fuel-wood, fodder for livestock and timber for villagers. From livestock milk, meat were sold to Banepa and Kathmandu became a major source of IGA to the people. Many NGOs and INGOs were supporting different community forestry. He suggested that the government and NGOs should be encouraged to work on community forestry based programmes. More awareness programmes should be implemented . Different kinds of training should be given to the user's group.

Prasai (2000) has out pointed in his dissertation that the community forest has fulfilled the different types of forest product wants. He noticed that the community forest was saving the time of people. If there was no community forest the house it had to spend more time for: collecting fuel wood and fodder. They used this saving time for other income generating work. He recommended in his study that the more awareness programmes are necessary to increase the use of improved stove, kerosene stove, bio-gas etc. to decrease the pressure on continuity forest for fuel-wood.

The Eight Plan (1985-1990) had taken a target of 5004 CFUGS formation but it could take the progress only 5314 CFUGs.

The community forestry has been receiving British aid from 1993. The Nepal UK Community Forestry Project (NUKCFP) is in operation. It worked in 4 districts of Koshi Hills and 3 districts of Dhaulabari Hills. A great success Dhaulagiri has been achieved during NUKCFP In the

formation of local level communities groups and developing mechanism to protect and manage forest.

Income Generating Activities (IGAs) are operated by some forest user groups in Koshi hills through NUKCFP initial grants and DFO support. The majority of the activities are concerned with inter-cropping in community forest. The CFUGs has been operating these activities with the main purpose of raising FUG's fund and to provide income/employment opportunities.

According to the report of Thapa, et. al. (1996) NTFPs (Non-Timber Forest Products) such as Bamboo, Cardamom, Ginger, Amliso, Chiraito, Turmeric, Lokta and Livestock are the main sources of IGAs which have been done in Koshi Hills on support of NUKCFP. NTFPs have the great importance to raise the economic status of village as well as nation.

K.C. (1993) in his report from four districts (Viz. Dhankuta, Sankhuwasabha, Ramechhap and Terhathum in Koshi hills) found that there were 291 FUGs in Koshi Hills up to December 1993 and only 17 CFUGs (15 FUG in Dhankuta, 2 FUGs in Terhathum) had applied for received project's grants to operate IGAs. Some other FUGs have been operating similar activities by their own investment or by the support from other sources.

In the study of Maharjan, et al. (1991) it is mentioned that 205 FUGs have received "seed money" from the project as financial support to introduce different types of IGAs through NTFPs in the Koshi hills and the CFUGs collected NTFPs worth NRs. 2,938,000. Some FUGs have introduced IGAs through their own fund which is not included in the project record. This shows that the Koshi Hills have a large potentiality to

mobilize its NTFPs to support the livelihoods of the poor, the women and minority groups.

Edwards, et. al. (1994) reported that about 100 varieties of NTFPs are exported to India from Nepal. Out of total quality of NTFPs exported "Chiraito" comprised about 50%. Edward (1994) found in his research that in some areas NTFP collection alone contributes on average 50% households' income.

Dahal, et. al. (1997) in a discussion paper pointed that up to July 1997, 292 CFUGs, in the Koshi hill area were involved in agro-forestry and animal based NTFP management. This paper also cleared some main reasons for inadequate management of NTFPs eg. lack of institutional capacity, lack of infrastructure (road, processing plants) under developed marketing mechanism, lack of clear-cut strategy guidelines and commitment by government to implement NTFP management plans and policy. In addition to that authority to manage NTFP" is not clear.

After the achievement of a great success from NUKCFP the livelihoods and forestry programme (LFP) has been applied in Koshi hills which is a bilateral programme of Government of Nepal and Department for International Development. United Kingdom LFP aims `to contribute to reduced Vulnerability and improve livelihood for poor rural people. It enhances the assets of rural communities through the promotion of more equitable, efficient and sustainable use of forest. resources (LFP, 2002).

LFP, this ten-year DFID programme started in April 2001, to operate in Sever hill districts, Dhankuta, Terhathum, Sankhuwasabha. Ramechhap of Koshi hills area . It focuses on forestry as a vehicle to improve the livelihoods of the rural poor of Nepal (LFP, 2002).

Department for International Development (DFID) comments some issues on poverty alleviation and uses an asset pentagon to show the different levels of assets available to individual.

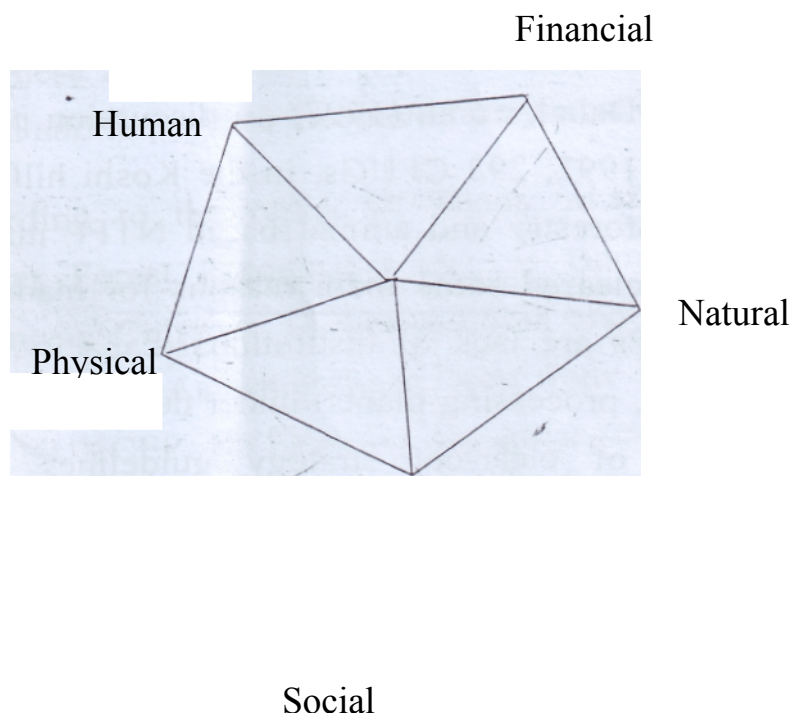

Source : DFID's Sustainable Livelihood's Guidance Sheets (DFID, 1998).

These assets are some times referred to as capital assets. Capital value of assets, can be accumulated and transferred, but it can also be depleted (Johnson, 1997). All these assets are come very different fields of research and they all have different policy levels affecting them.

Table No. 2.1: Different Capitals and Their Fields of Research and Nature of Policy.

Types of Capital	Definition	Field of Research	Area of Policy
Natural Capital	Natural resources such as forestry from which	Soil Science, Natural resource management, water management, etc.	Policies are technically and concerned with sustainable management

	<p>people gain useful products and services.</p> <p>Access to and quality of resources are important issues.</p>		
Human Capital	<p>Skill, knowledge, ability to labour, good health enable people to pursue and achieve livelihood strategies and objectives</p>	Medicine, Education	<p>Policies are concerned with increasing individual capabilities, literacy classes, health issues, and family planning</p>
Social Capital	<p>Social resources, which people draw in to pursue livelihood objective .</p>	Sociology, Gender	<p>Gender issues, decision making power, trust and reciprocity.</p>
Financial Capital	<p>Financial resources people use to achieve livelihoods objectives</p>	Economics	<p>Increasing incomes, Micro finance and Micro credit, income generating activities</p>
Physical Capital	<p>Basic infrastructure and producer goods needed</p>	Construction	<p>Access to clean water, roads, electricity and schools.</p>

	to improve livelihoods.		
--	-------------------------	--	--

Source : DFID's Sustainable Livelihoods Guidance Sheets 1998.

Similarly, the pentagon is presented in a very simple way, making it look the assets with all their different policy can be combined together to achieve the common goal of poverty alleviation. It is implied that policies from such diverse fields can easily be combined together and will fit smoothly resulting in the improvement of livelihoods. Although the types of capital are very disparate in nature, they are complementary. One policy alone is unlikely to improve the livelihood of an individual. For instance building a road has a positive impact by reducing the time taken to places, but this alone is unlikely to improve livelihoods.

LFN has taken an aim to develop all these assets to achieve its goal.

There are great potentiality of NTFPs in Ramechhap which are main sources of IGAs for the people. The main objectives of IGAs in LEP area are as follows :

- to create opportunities of employment and income generation for rural people through forestry and non-forestry IGAs.
- to maximize the return from forests through intensive and sustainable use of land.
- to encourage participation of poor and women members of the communities in decision making and benefit sharing in CF.
- to improve market access and information system related with NTFP enterprises for FUGs (Dev. 2001).

According to Tenth Plan (2002-2007); Nepal has been able to introduce itself as a country of Community Forestry in the world. With the help of Community forestry, Nepal has improved in the Field of forest, environment, bio-diversity and sustainable management and socio-cultural development. Through the medium of social justice and social improvement etc. have been launched in the local community. Community forests have been handed over to the local communities to improve the livelihoods C people below the poverty line (NPC, 2003).

According to Interim Plan (2007-2010), to stop the encroachment of forest, commercialization of its products, conservation and utilization of herbal products and the overall long term management of the forest areas are its major challenges. To develop internal market, promote exports, and generate employment by promoting forestry and forest-base industry, ensure regular supply of forest-based products by long term management of aquatic and geographical diversity, forest, plants, following policies are to be implemented:

- The necessary legal provision and procedural process are respected reformed to effectively manage the development of forestry.
- For the long term development of forest and aquatic areas, the peoples' participation are to be ensured thereby generating opportunities for the income from long-term management of forest, forest-related products, herbs, land and aquatic, environment, geographical diversity and forest related products' business.
- The reach of the poor are to be ensured by justifiable distribution system and community forest management, long-term forest management and by increasing forest-based products and its

supply.

- Some 35 per cent of the income of the community forestry are respected invested on the dalit, indigenous, nationalities, madeshi, handicapped, women and poor people's productive business.
- The reach of indigenous nationalities and the locals are to be ensured in the community forestry and its management.
- Monitoring of community forestry are to be made effective.
- The total area covered by the forest are to be marked.
- Programmes are to be brought by reforming necessary policies for the long-term management of aquatic area.
- Priority are to be given to local Tharu community, indigenous nationalities and madeshi (Muslim and backward community) in Terai for the management of community forestry.
- Forest development fund are to be set up by collecting fixed percentage of amount from buyers while selling forest-related products and a fixed percentage from the revenue generated by the sale of these products. The amount are to be used in the tree plantation and long-term forest management and poverty alleviation.
- The wasted land on the river banks are to be conserved and utilized, and bonded- forest programme are to be expanded to improve the livelihood of the families under the poverty line.
- Forest, agriculture, land and water conservation like related subjects are to be managed in a unified manner.

- A package programme are to be brought for Seti, Mahakali, Rapti, and Karnali by declaring them Herbs Zone.
- A special programme are to be brought for the people of Himalayan region for the conservation, management, and promotion of hers and forest animals.
- The western Himalayan region are to be declared a conservation area and programme are to be brought for its special conservation and social development.
- The role of the local community are to be increased in the management of conservation area.

Conceptual Framework of the Study

The framework of this research shows that community forestry is the 'Yam' of local rural communities. CF define as protection management and participation of local people. It helps to the local people directly and indirectly involves various sectors. The following diagram describes the role of community forestry in the subject of income generation as well as local people participation.

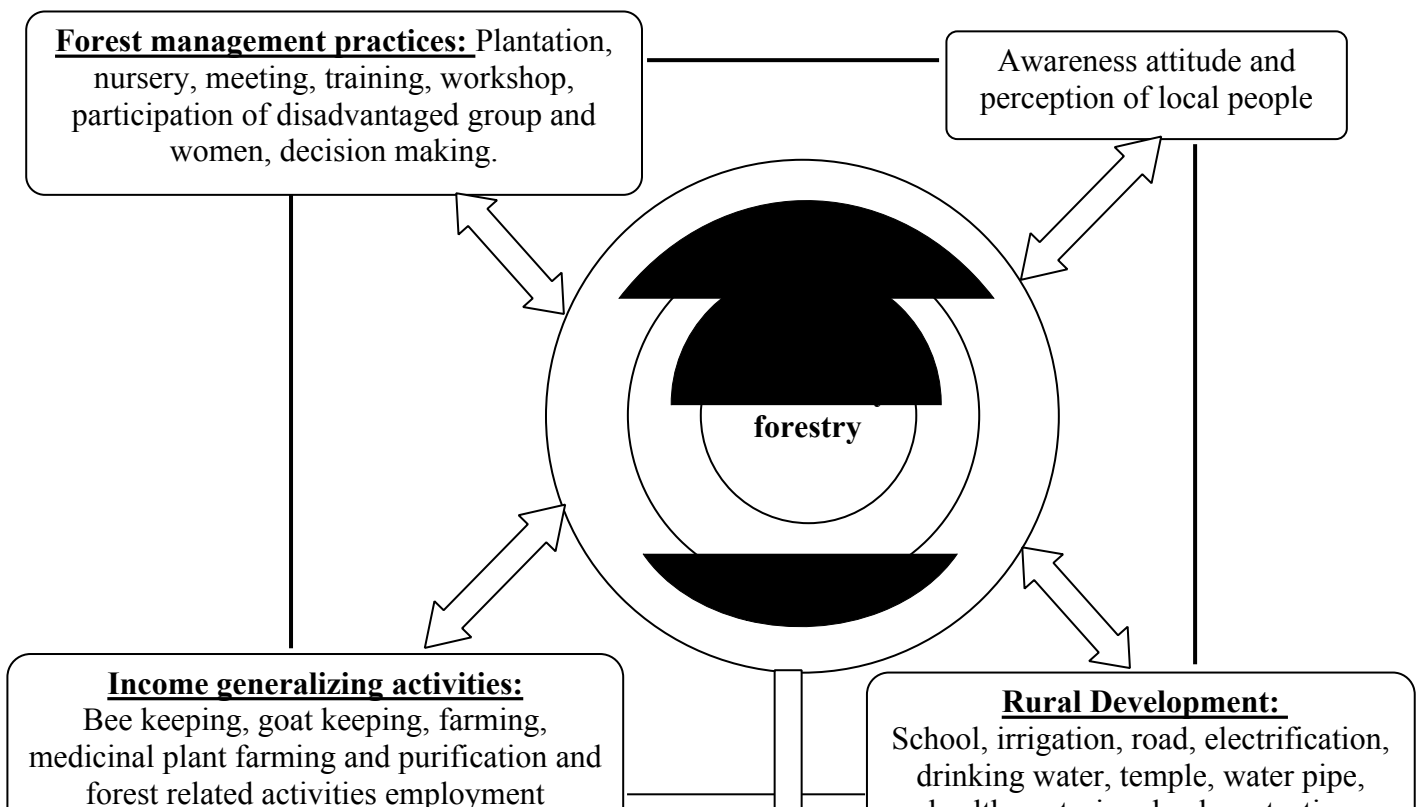

After the emergence of the community forest approach of this study
Source: Forestry Bulletin, 2060
area various developmental activities like, rural infrastructure
development, income generating activities, a forest management practices
and people's participation like decision making also

CHAPTER-III

RESEARCH METHODOLOGY

Research methodology is the most crucial and determining elements for the soundness and reasonableness of research output in any field of study. In this chapter includes research design, population of the study, sample and sampling procedure, source of data, data collection tools and techniques, data processing and data analysis respectively.

3.1 Research Design

The study has adopted both the descriptive and exploratory research designs. Descriptive research design is concerned with the describing the characteristics of a particular individual, as of a group. Community forest user group's character and their rules and process in community forestry activities are descriptively discussed. Exploratory research design finds out some problems and then analyses these problems applying different research methods.

3.2 Sample and Sampling Procedure

The study had been selected the community forestry user group at Namadi VDC Ward No. 4, 5 and 6. Out of 310 households, 13 percent 40 households had been sampled with purposive sampling method:

3.3 Sources of Data Collection

The present study is based on both primary and secondary data. The primary data had been collected from the field of the study area. Similarly, the secondary data had been used for the deep study which are collected from published or unpublished written documents, individuals experts and organization related to forest.

3.4 Data Collection Tools and Techniques

On the process of data collection tools and techniques are important. The collection of primary data had been done with the help of structured questionnaire, field observation, FUGs meeting observation, household head interview as well as focus groups discussion methods.

3.4.1 Questionnaire Survey

Structured questionnaire had been prepared to generate the realistic and actual data from households survey of the participated households. The respondents have requested to fill up the questionnaire.

3.4.2 Key Informant Interview

The primary data had been collected from key informants using semi or unstructured questions. The interview had been taken as cross checking for data obtained from questionnaire.

The informant had been interviewed on the impact of community forestry on local activities like development, income of user groups, living standard. In this process, information had been taken from politician, VDC secretary, chair-person of user groups, local teachers, social worker and so on.

3.4.3 Field Observation

Forty HHs which were selected by purposive sampling had been visited and income generation activities had been observed in various sectors. And it has been recorded in file. This was very useful to know that what was recently happening in the study area.

3.4.4 Focus Group Discussion

The focus group discussion had been located in the famous place of village with active participation of all; men, women, ethnic groups, children, youths and old persons. The discussion was started focusing the community forestry activities in local area and its impact on income generation activities and on more issues.

3.5 Data Processing

The table is formulated from questionnaire and interview about income, family size, educational status, production etc. Some summary measure like percent, mean are used to make results.

3.6 Data Analysis

After finishing interview schedule from field observation collected data had been processed. Simple statistical tools like table, graphs, bar diagram, pie chart etc. has been used for data analysis. In this stage, descriptive method was used for qualitative data.

CHAPTER - IV

INTRODUCTION OF THE STUDY AREA

4.1 Country Background

Nepal is the small landlocked country with the area of 147181 sq. km. (14.7 million hac.) located between two huge countries: China and India. She lies between 26⁰22" to 30⁰27" north and 80⁰12" to 88⁰12" east. She has huge diversity in culture and ecology although she is one of the poorest countries in the world. The country has wide range of biological diversity and five physiographic zones viz.: Terai, siwalik, middle mountains, high mountains and high Himal (HMG/N, 1998). Country includes 21 million people with different ethnic groups, cultures and castes. Forests cover about 38% of the country including 59% broad-leaved stands, 24% mixed conifer broad leaved stands, and 17% conifer stands from tropical to alpine climatic zones. The forestry sector contributes the national economy by providing 16% of the country's GDP and employing 18% of the total labor force.

4.2 Glimpse of Ramechhap District

Ramechhap district is recognized as less an industrial district which lies in Janakpur zone, the central development region of Nepal with an area of 1564.33 sq. km. and its headquarter is at Manthali RCP district consists of two major types of physiographic, viz. shadows of a Mahabharat hill that is in the southern side with steep slopes and Numbur Himal, which is rugged in all aspects. The (Tame and Shailung) Thodung, Nopra are dissected by many shallow rivers and streams, which change course from time to time. Main rivers are Likhu, Khimti, Tamakoshi, Sunkoshi, Chauri Khola and others are Tilpang, Pharpu, Haluwa, Palati, Chahare, Sabra, Sapsu, Ghyang Khola, Bhatauli Jatapokhari and Pachin Pokhari.

Figure No. 1: District Map of Ramechhap (Land use map)

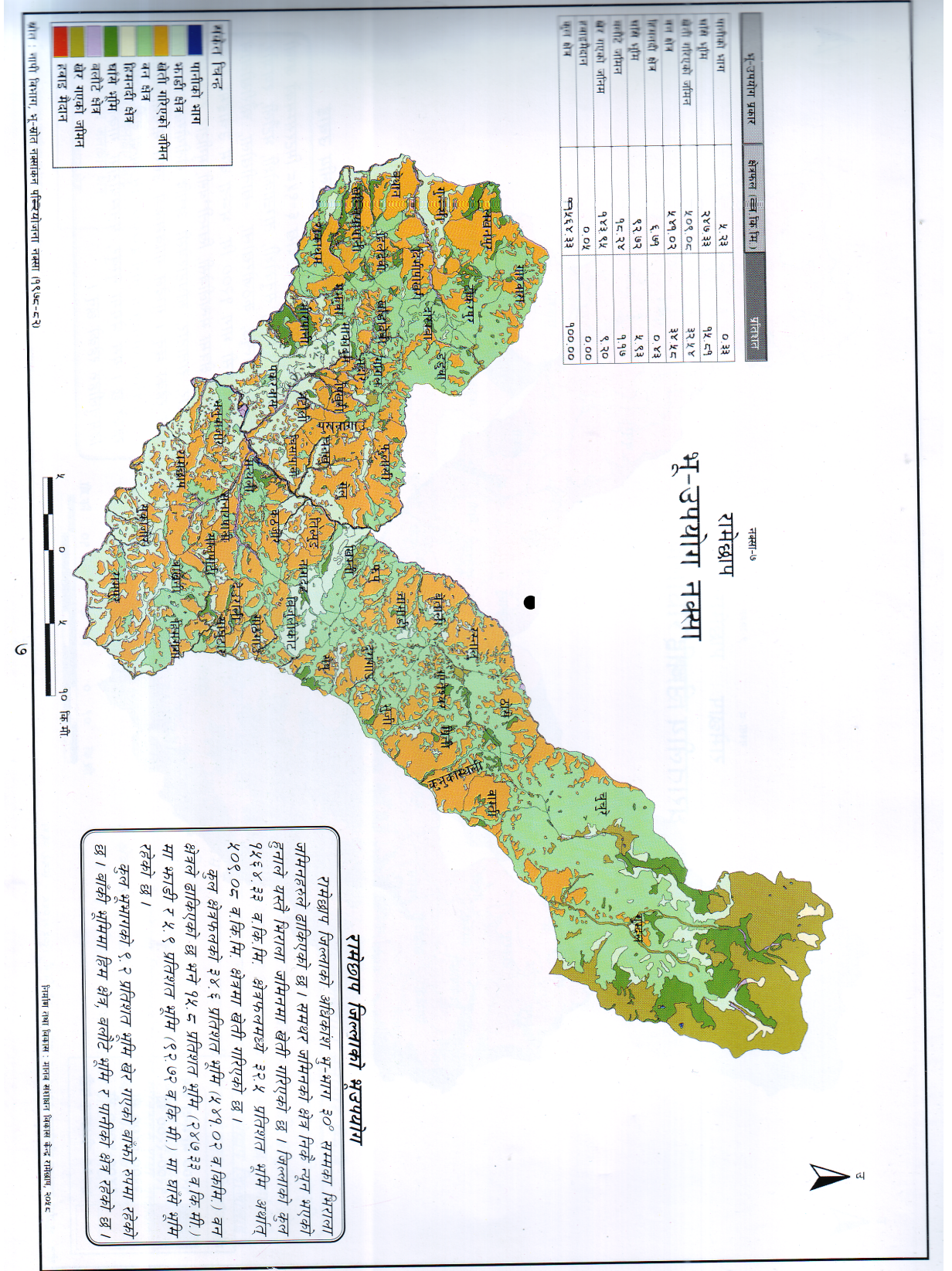

4.2.1 Geographical Condition

Ramechhap district is located between 27°28" to 27°50" north latitude and 85°50' to 86°35' east longitude. Its altitude ranges from 369 m to 6958 m. The political boundary of this district is Dolkha, Kabhre Planchowk and Sindhupalchowk in the west; Dolkha district in the North; Sindhuli district in the South and Solukhumbu, Okhaldhunga in East.

4.2.2 Major Ethnic Composition in Ramechhap District

According to the census, 2058, the total population of the district is 212408 where male occupy 100853 (47.48%) and left are female 111555 (52.52%). The number of total HHs, in Ramechhap district, is 40386 HHs at the average of 5.26 people per house hold. The population growth rate is nearer to national growth rate i.e. 2.21% most of the people lives in rural area, almost 82.56% of the population and the literacy rate of the district is 44.54% (above 6 years), among them male carry the 61.5% and female 27.25% only (2058). Similarly, Tamang (20.34%) is the major ethnic group in the district. Respectively, Brahmin (5.60%), Chhetri (26.31%), Newar (14.06%), Magar (10.90%), Kami (3.02), Damai/Dholi (1.87%), Majhi (2.59%), Sunuwar (4.18%), Sarki (2.63%), Sherpa (2.38%), Gharti (1.40%), Sanyashi (0.81%), Thami (0.76%) and others (3.21%).

4.2.3 Socio-economic Situation

Manthali is the headquarters of district. A majority of the population works in the agriculture sector despite the level of industrialization. Some 47 percent have other occupation. But, the agriculture occupation level is below the national figure 80 percent (DDC

Profile, 2007). Similarly, the literacy rate is which is below the national figure (DDC Profile, 2007).

4.2.4 Land Use

Total area of Ramechhap district consists of 1564.33 sq. kilometer ha and the largest part is covered by forest land. Similarly, agriculture land. The land use of the district is presented in figure 2.

Figure No. 2: Land Use Pattern in Ramechhap District

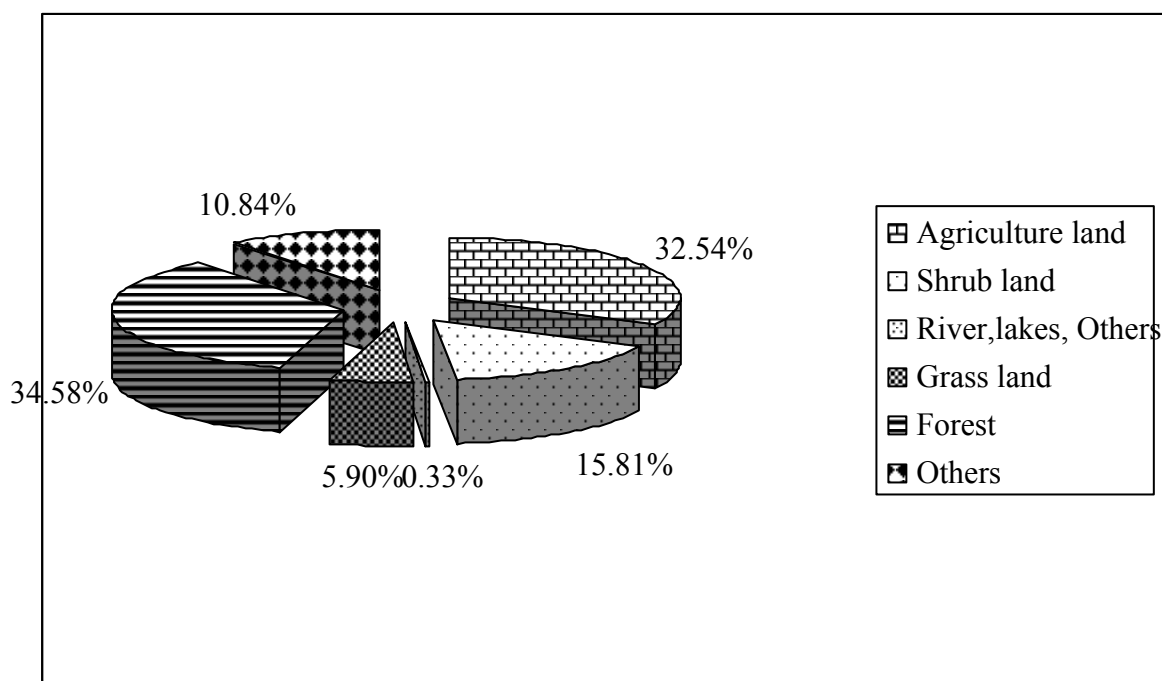

Source: DDC, 2008.

4.2.5 Climate and Soil

Climate varies from tropical, sub-tropical to temperate. Average annual rainfall of the district is 2535 mm and minimum temperature is 36.3 and 16.6 respectively. Its geology is tertiary Siwalik to the North the Mahabharat range to the south. And its soil consists of red soil around black, white, sandy eage or river.

4.2.6 Community Forestry in Ramechhap

The community forestry programme has been a learning programme in the district since 1990, after restoration of democracy through popular people movement. The Nepalese government emphasized people participation in forestry programmes through forest user group. In 1990/1991, there was only one community forest and handed over to user group, but the process was accelerated after the implementation of the forest regulation 1993. Until 2008, 287 community forest user groups have already been registered in the District Forest Office. It covers 23644 ha. forest area, about 32671 household are participating in the community forestry movement through being general user member (DFO, 2009).

Table No. 4.1: Land Holding Pattern in Ramechhap District

S.N.	Landholding pattern	No. of HHs of Total HHs
1	Land less HHs	0.8%
2	0.1 ha to 0.2 ha	13.5%
3	0.2 ha to 1 ha	67.3%
4	1 ha to 2 ha	15.5%
5	2 ha to 5 ha	2.4%
6	5 ha to 10 ha	0.3%
7	above 10 ha	0.2%

Source: DDC, 2007.

4.2.7 Religions Composition of Ramechhap District

The people of this district consist of different ethnic groups believing in different religions. The following table presents the religions composition of Ramechhap district.

Table No. 4.2: Religious Composition of Ramechhap District

S.N.	Religions	No. of people	Percentage
1	Hindu	144010	67.8
2	Buddha	60074	28.3
3	Islam	42	0.019
4	Kirat	4141	2.0
5	Jain	4	0.0018
	Christian	913	0.4
	Sikh	14	0.0065
	Others	3210	1.51
	Total	212408	100.00

Source: CBS, 2001.

4.3 Village Profile

Namadi VDC is located in the electoral constituency no. 1 of the Ramechhap District and the northern side of the district headquarter. It is surrounded by Duragyan VDC to the east Shahare and Chhayama VDC of Dolakha District to the west and Betali Pharpu VDC to the South VDC to the North.

The total population of this VDC is 3981 out of which 1778 are male and 2203 are female. And the total household of this VDC is 839.

Namadi VDC is known as the kitchen garden of Manthali Bazaar. Which is nearly one and half hours far from district headquarter using by bus. The total number of people of this VDC have been engaging on agricultural and livestock. Green vegetables, milk, rice, meat, potato and other food crops have been supplied from this VDC weekly and daily to Khimti, Potato and Manthali Bazaar. The following table shows the number of households having agricultural land, livestock and poultry farm for the VDC.

Table No. 4.3: Household having Agricultural Land, Livestock and Poultry for Namadi VDC

S.N.	Articles	HHs	Percentage
1	Agriculture land	78	9.20
2	Livestock	4	0.47
3	Land and livestock	140	16.59
4	Land and poultry	10	1.14
5	Livestock and poultry	5	0.60
6	Land livestock and poultry	590	70.29
7	Non for all	14	1.68
	Total	839	100

Source: CBS, 2001.

In the Namadi VDC mainly Tamang, Brahmins, Kshetri, Newar, Sunuwar, Kami, Damai, Sarki, Gharti, etc. ethnic groups are living. The following table shows the different groups of castes in the Namadi VDC.

Table No. 4.4: Total Number of Population According to Caste Others Groups

S.N.	Caste	HHs	Percentage
1	Tamang	382	9.60
2	Brahmins Hill	25	0.62
3	Kshetri	2407	60.46
4	Newar	63	1.58
5	Magar	6	0.15
6	Kami	121	3.03
7	Sunuwar	254	6.38
8	Damai/Dholi	92	2.31
9	Gurung	123	3.08
10	Sarki	107	2.68
11	Sherpa	151	3.79
12	Gharti Bhujel	218	5.47
	Total	3949	100.00

Source: CBS, 2001.

Namadi started its educational steps from 2011 B.S. with the establishment of Shree Kamala Devi Primary school which was first government school of Namadi. At present this school is become a Higher secondeary school. And there are 4 other primary schools and one lower secondary school in this VDC which are made by government.

The following table presents the educational status of this VDC.

Table No. 4.5: Population 6 Year of Age and Over by Literacy Status and Sex for VDC

Types	Male	Female	Total	%
Cannot read and write	271	580	851	32.25
Can read only	55	24	79	3
Read and write	901	783	1684	63.81
Not stated	6	29	25	0.95
Total	1227	1412	2639	100.00

Source: CBS, 2001.

The above table 4.5 shows that the large number of females are illiterate in this VDC. And more males are educated than female. The main cause behind it is that the females must engage in household work. So, they can get less opportunities to go to school.

Figure No. 4: Population 6 Year of Age and Over by Literacy Status and Sex for VDC

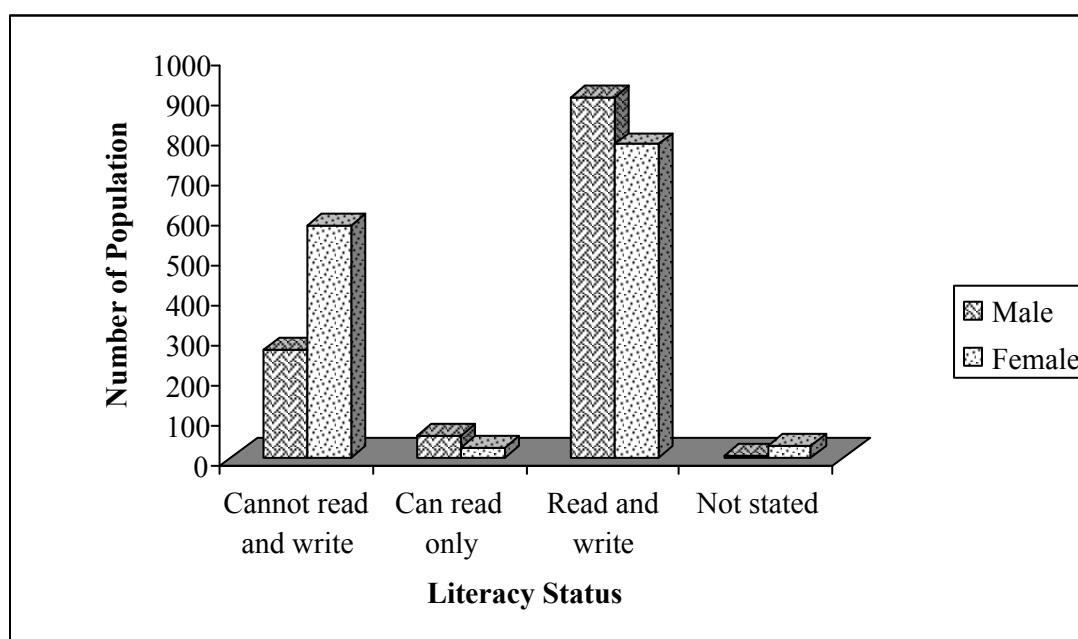

About the total forest area of this VDC 1907.98 hectares are covered by CF. There are 7 CFUGs in this VDC, which include 1333 households.

Sources: Community Forest Division, Department of Forest, Kathmandu, Nepal.

4.4 Description of the Selected CFUGs

Ramite CF lies to the north of Pharpu VDC and west of the Dolkha district Shahare, South of Dolkha VDC and east Namadi Ward No. 8. This CF handed over in 2056 B.S. to the local people. The large part of this forest lies in the Namadi VDC Ward No. 6. The total area of this forest is 264 hectares which is covered by natural forest and plantations.

It is located along with the bank of Khimti river, in this river 60 M.W. Hydropower constructed and running 2057. Now a days the hydropower called Khimti and Hydropower.

Regarding the ethnic composition in CFUG Chhetri (55.35%) is top most population and followed by Sunuwar and Chhetri (31.60%), Sharki (4.43%), Kami (3.47%) and similarly about 6.5% consists of others ethnic groups. Namely, Newar, Magar and Damai. The major positions of CFUG is headed by Chhetri because of the population is high with respect to other. In shortly, Ramite CFUG is known as an active community forest in Namadi VDC. It is also investing major parts of its income in the field of social development and in community as well.

CHAPTER-V

SOCIO-ECONOMIC STATUS OF THE STUDY AREA

This chapter introduces number of HHs, Ethnic composition, family size, sex composition, educational status, occupational composition, distribution of landholding, feeding pattern of livestock, crops production and well being ranking of sampled household and its table, graphs and figure orderly.

5.1 Total Number of Households and Sample

The total number of CFUGs are 7 in the Namadi VDC out of them Ramite CFUG was taken for this case study. There are 310 HHs among them nearly 13% (40) HHs are taken as sample purposively for this study.

5.2 Ethnic Composition of Sampled HHs

Truly, Nepal is a garden of various ethnic groups. Similarly, in the study area (Namadi VDC) where the forest users are consisted of various ethnic backgrounds. The caste and ethnicity play important roles for socio-economic development in Nepalese society. But there has been found a good relationship and participation among all caste groups in the study area. Lower castes also have been involving in every social and developmental work without any discrimination.

The following table show the ethnic composition of the sampled household in CFUGs.

Table No. 5.1: Ethnic Composition of Sampled HHs

S.N.	Caste	HHs	Percentage
1	Chhetri	15	37.5
2	Sunuwar	7	17.5
3	Gharti	3	7.5
4	Kami	5	12.5
5	Damai	3	7.5
6	Newar	4	10.0
7	Sarki	2	5.0
8	Brahmin	1	2.5
	Total	40	100.0

Source: Field Survey, 2010.

The above table 5.1 shows that the major percentage of total HHs are Chhetri, in the study area. After Chhetri caste, the percentage of Sunuwar, Kami and Newar castes comprise second highest in rank.

Figure No. 5: Ethnic Composition of Sampled HHs

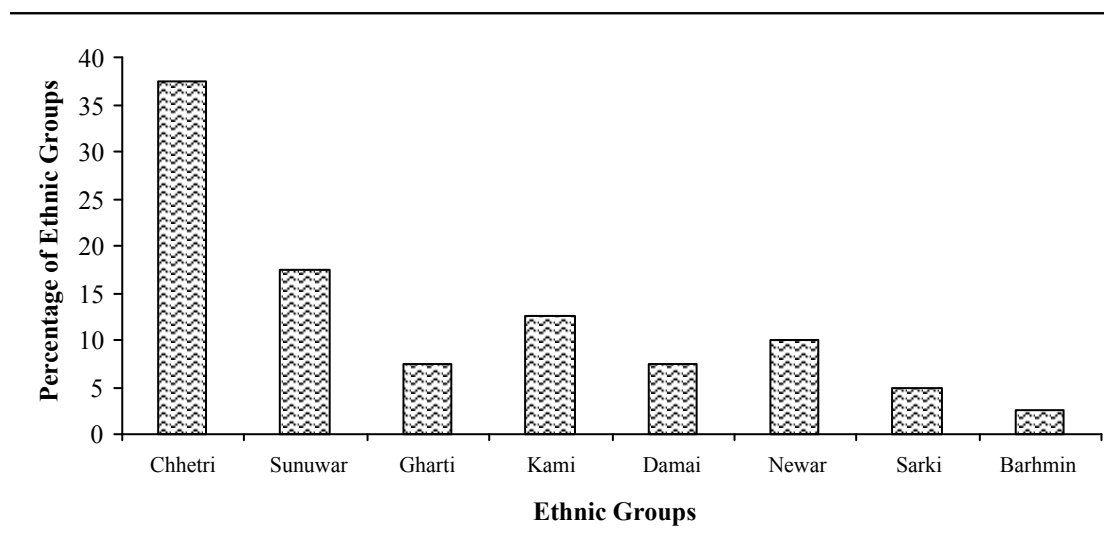

5.3 Family Sizes of Ethnic Groups

The family size affects the economic health, social and educational conditions of the family, from the tables below we can see the family size of various ethnic groups.

Table No. 5.2: The Family Size of Ethnic Groups in Sample HHs

Caste	No. of HHs	Total no. of family members	Average family size
Chhetri	15	68	4.53
Sunuwar	7	31	4.42
Gharti	3	13	4.33
Kami	5	27	5.40
Sharki	3	15	5.33
Newar	4	17	4.25
Damai	2	11	5.50
Brahmin	1	4	4.00
Total	40	187	4.72

Source: Field Survey, 2010.

The above table no. 5.2 shows that the average family size of lower castes as Damai, Kami, Sharki have large number 5.4 and the other castes have smaller family size comparatively. 4.3 and average 4.72 in sample HHs.

5.4 Sex Composition of Sampled HHs

Sex composition is one of the most important demographic features for the planners. Separate data for males and females are important for various types of planning. It will help to know which sector is weaker and

support they can do for uplifting the sex. The balance of sexes affects the social and economic relationship within a community.

The following table shows the sex composition of sampled household.

Table No. 5.3: Sex Composition of Sampled Households

Households	No. of females	Percentage	No. of males	Percentage	Total	Percentage
1	3	3.06	4	4.49	7	3.74
2	2	2.04	2	2.24	4	2.14
3	4	4.08	2	2.24	6	3.21
4	6	6.12	2	2.24	8	4.27
5	1	1.02	2	2.24	3	1.60
6	2	2.04	4	1.12	3	1.60
7	3	3.06	2	2.24	5	2.67
8	3	3.06	3	3.37	6	3.21
9	2	2.04	3	3.37	5	2.67
10	4	4.08	2	2.24	6	3.21
11	1	1.02	3	3.37	4	2.14
12	4	4.08	3	3.37	7	3.74
13	1	1.02	3	3.37	4	2.14
14	1	1.02	4	4.49	5	8.67
15	1	1.02	1	1.12	3	1.06
16	2	2.04	1	1.12	3	1.60
17	1	1.02	3	3.37	4	2.14
18	3	3.06	2	2.24	5	2.67
19	2	2.04	2	2.24	4	2.14
20	2	2.04	3	3.37	5	2.67

21	3	3006	2	2.24	5	2.67
22	4	4.08	1	1.12	5	2.67
23	1	1.02	2	2.24	3	1.60
24	2	2.04	1	1.12	3	1.60
25	3	3.06	4	4.49	7	3.74
26	1	1.02	3	3.37	4	2.14
27	5	5.10	2	2.24	7	3.74
28	3	3.06	2	2.24	5	2.67
29	3	3.06	2	2.24	5	2.67
30	2	2.04	3	3.37	5	2.67
31	4	4.08	1	1.12	5	2.67
32	3	3.06	2	2.24	5	2.67
33	1	1.02	3	3.37	4	2.14
34	2	2.04	2	2.24	4	2.14
35	4	4.087	1	1.12	5	2.67
36	2	2.04	3	3.37	5	2.67
37	1	1.02	2	2.24	3	1.60
38	1	1.02	2	2.24	3	1.60
39	3	3006	1	1.12	4	2.14
40	2	2.04	2	2.24	4	2.14
Total	98	100	89	100	187	100

Sources: Field Survey, 2010.

The above table 5.3 shows that out of total 187 persons, 98 are females and 89 are males. This proves that in this study area, there is little difference between females and males in number.

5.5 Educational Status of Sample Household According to Sex

Education is considered as a human capital and important infrastructure of the development as well. It plays a crucial role in all sectors of all society. In modern age, all the planners agree in the fact that development without participation of local people is almost impossible. for this purpose if all persons of households is educated then participation of them for any development activities are more effective. It can be said that if all persons of households are educated then the society is more conscious about the problem of the community, needs of the community and become able to provide more appropriate solution.

In this study the education status has been classified in to five groups. They are:

- i. Illiterate
- ii. Literate (either form formal on non-formal education)
- iii. Primary
- iv. Secondary
- v. Higher secondary

Illiterate are those who cannot read and write. Literate represent those persons who can read or write either from formal or non-formal education. Primary education means the academic education up to class five. secondary in known as the academic education up to S.L.C. and higher secondary education in that the academic education above S.L.C Level.

The education status can be seen on the following tables in sampled households.

Table No. 5.4 : Educational Status of Sampled Households

Level	No.of females	Percentage	No.of Males	Percentage	Total	Percentage
Illiterate	34	34.69	6	6.74	40	21.39
Literate	16	16.32	20	22.47	36	19.25
Primary	21	21.42	23	25.84	44	23.52
Secondary	18	18.36	25	28.08	43	22.99
Higher	9	9.18	15	16.85	24	12.83
Total	98	100	89	100	187	100

Source: Field Survey, 2010.

The above table 5.4 shows that out of 187 Population of total, 21.39% persons are illiterate and 19.25% persons can a little read write and only a few persons have got higher education in the sampled HHS.

Figure No. 6: Educational status of sampled Households

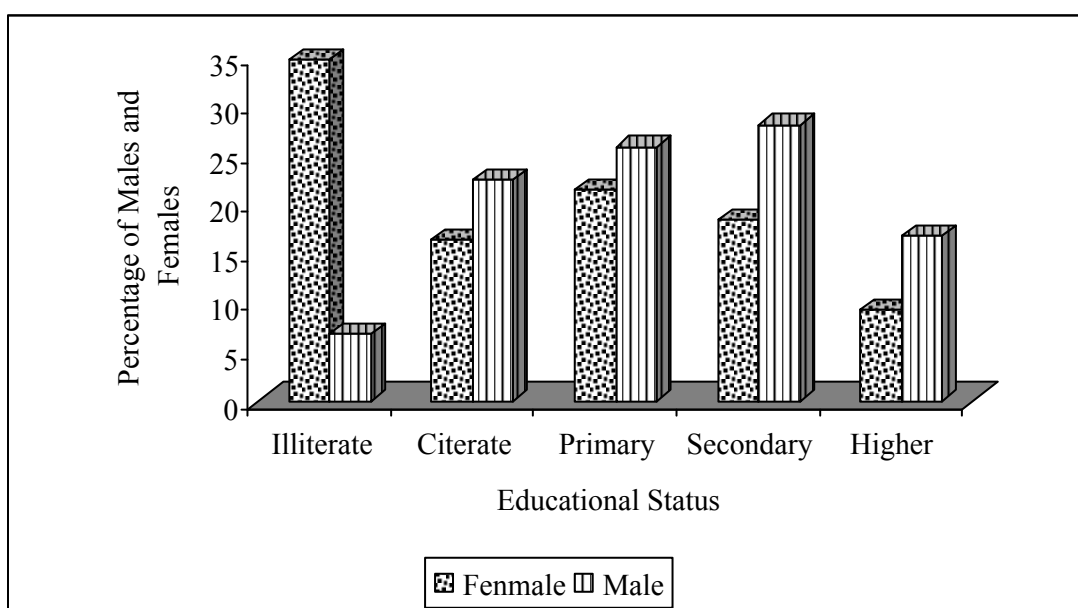

Source: Field Survey, 2010.

Comparing male and female, the larger percent of females are found illiterate and only a small percent of females can a little read and write.

5.6 Occupational composition of sampled Households

Agriculture is main occupation in Nepal. This trend can be seen in the study area also and livestock is an additional occupation of this area. The main sources of income are agriculture and live stock. Moreover, some household are engaging in non-agricultural occupation such a service, business, wage labour and traditional (caste-wise) profession. The tables below show the occupational composition of sampled HHS.

Table No. 5.5: Occupational Composition of Sample Households

Occupation	No. of Households	Percentage
Agriculture and live Stock	19	47.5
Service	6	15
Business	3	7.5
Wage labour	9	27.5
Traditional profession	3	7.5
Total	40	100

Sources: Field Survey, 2010.

The above table 5.5 shows that nearly 48% of the total sampled households are exercising in agriculture and livestock occupations other households are engaged in other professions like service, business, wage labour, etc.

Figure No. 7 : Occupational Composition of Sample Households

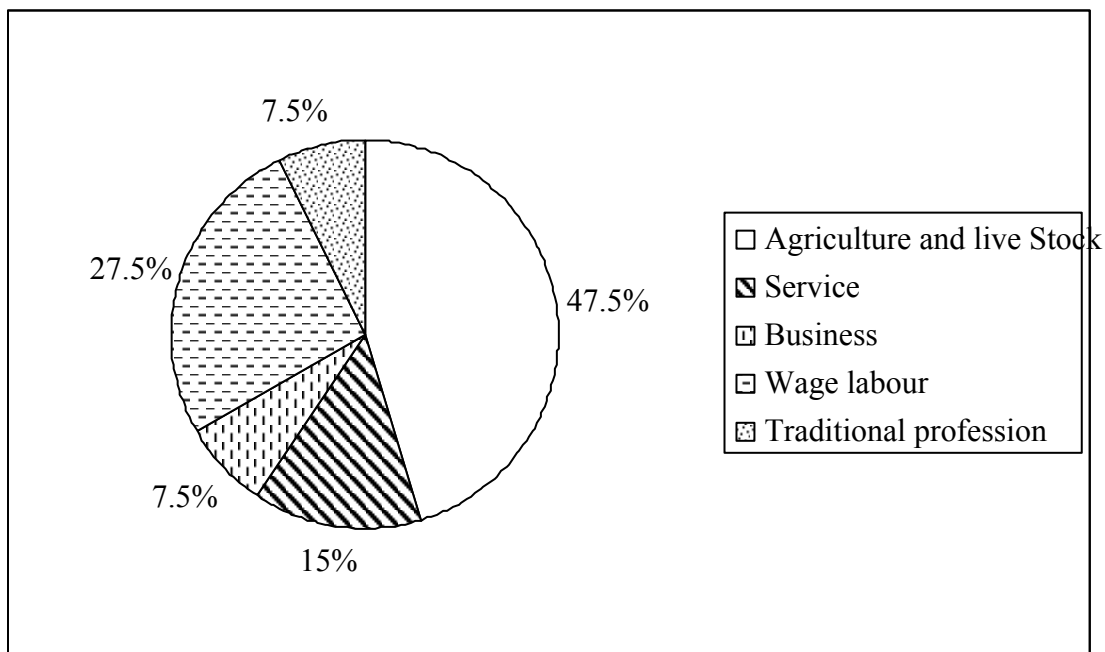

Sources: Field Survey, 2010.

5.7 Distribution of Livestock Holding in the Sampled Households

Livestock is one of the important occupations of Nepalese people for getting milk, meat, manure, ploughing ghee, eggs etc. Livestock is also a means of liquid assets which can easily be converted in to cash during crisis. Livestock play a multi-functional role in Nepal's farming system. They provide milk, meat, and draught power for tilling the land and manure for the maintenance of sails." (Streak 1998).

The following tables show the total number of livestock holding at present in the sampled households.

Table No. 5.6: Distribution Livestock Holding of Sample Households

Types of Animals	Average No. of perttis live stock	Percentage
Buffalo	1.00	6.82
Cow /ox	1.85	12.62
Goat	3.55	24.23
Chicken	6.80	46.41
pig	1.54	9.89
Total	14.65	100

Sources: Field Survey, 2010.

The above table 5.6 shows that out of total average 14.65 livestock, 46.41% are chicken, after it the highest percentage of livestock is goat which is 24.23% After then the percentages of cow pig and buffaloes followed.

5.8 Feeding Pattern of Livestock in Sampled HHs

Most of the people of the sampled households keep their livestock by stall-feeding. No one keeps their lives for grazing. So, forest products have not been destroyed by animals. It is a hard and fast rule making by all users not to graze their animals in the CF area, If it is found the person who grazes the animals he must pay fine. Therefore, all household usually collect forage, grass and edible weeds from the forests and form lands to feed their livestock.

5.9 Distribution of Land Holding in Sampled Households

Land holding is one of the most important determinants of the income and food sufficiency. More than 45% households have not Khet (irrigated land). So all of them use to spend their income for purchasing rice.

The following tables show the average land holding pattern of sampled household in the CFUGs.

Table No. 5.7: Distribution of landholding pattern in Sample Households

Land size (In Ropani)	No of Households	Percentage
Land less	-	-
Less than 5	9	22.5
5-10	11	27.5
10-20	13	32.5
20	7	17.5
Total	40	100

Sources: Field Survey, 2010.

Figure No. 8: Distribution of Land Holding Pattern

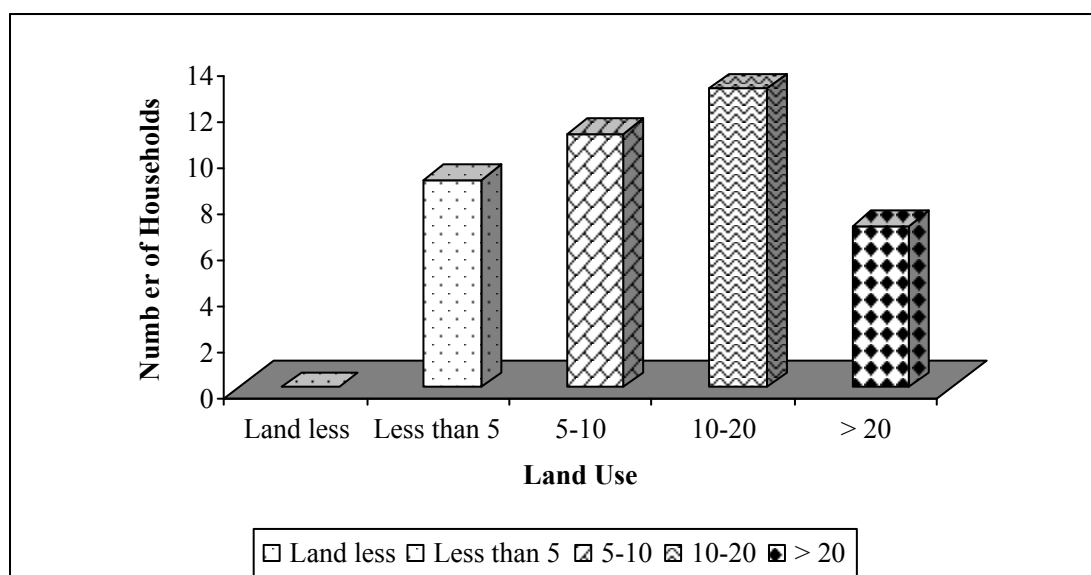

Sources: Field Survey, 2010.

The above table 5.7 and figure no. 6 show that the majority of households have been holding in between 10 to 20 rapani land, few (only 7) households are getting more then 20 ropani land

5.10 Crops Production of Sample Households

Differed kinds of crops are the main source of food for villagers. Paddy, maize, millet are the main crops production of the study area. So, mainly these 3 crops are calculated.

The average crops production are in the following tables.

Table No. 5.8: Distribution of crops production in Sampled Households

Crops production (In Muri)	No. of households	Percentage
Less than 5	13	32.5
5-10	9	22.5
10-20	6	15
20-30	8	20
30	4	10
Total	40	100

Sources: Field Survey, 2010.

Note;- 1 Muri = nearly 50kg

Figure No. 9: Distribution of Crops Production in Sampled Households

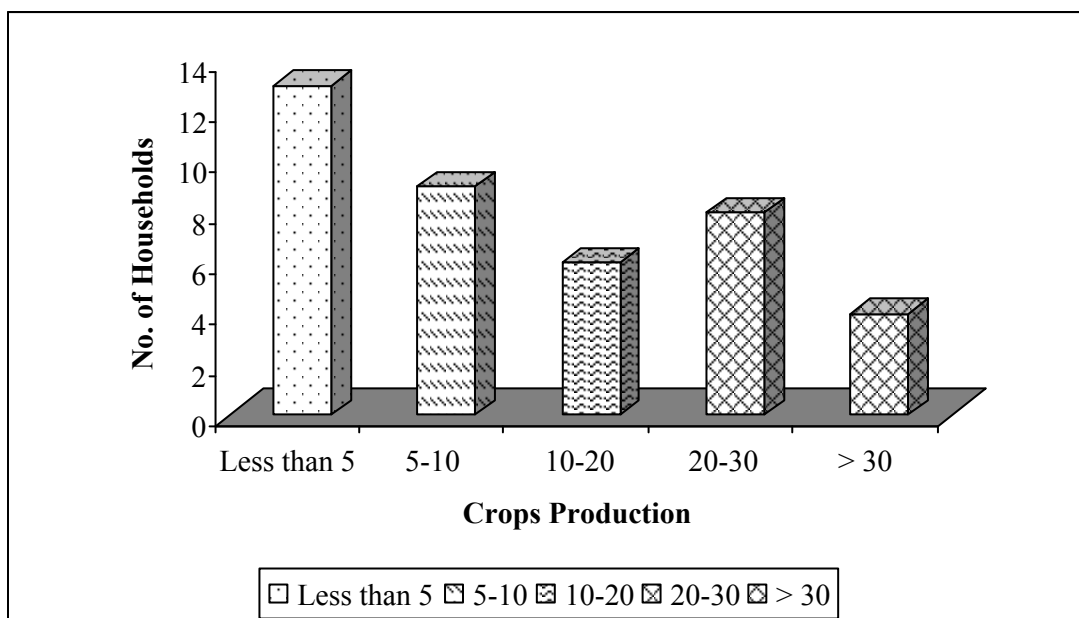

According to above table 5.8 and figure no. 9, show that more than 50% households have only up to 10 muri crops Production from their own land in a year . so, this clearly shows that there is food problem among those households.

5.11 Well-being Ranking of Sampled Household

To introduce the economic status of user's households, 'well-being ranking, the tool of PRA has been applied. This has been done with the help of DFO, RP and NGO on the basis of landholding size, family size, food sufficiency from their own land, off farm income such as remittances from pension, services in different organizations.

The following tables show the well-being ranking of sampled households in the basis of food sufficiency.

Table 5.9: Well-being Ranking of Sampled Households

Particulars	No. of HHs	Percentage
Food sufficient below 3 months	4	10
Food sufficient upto 3 months	13	32.5
Food sufficient upto 6 months	7	17.5
Food sufficient upto 9 months	5	12.5
Food sufficient upto 12 months +	11	27.5
Total	40	100.0

Sources: Field Survey, 2010.

Figure No. 10: Well-being Ranking of Sampled Households

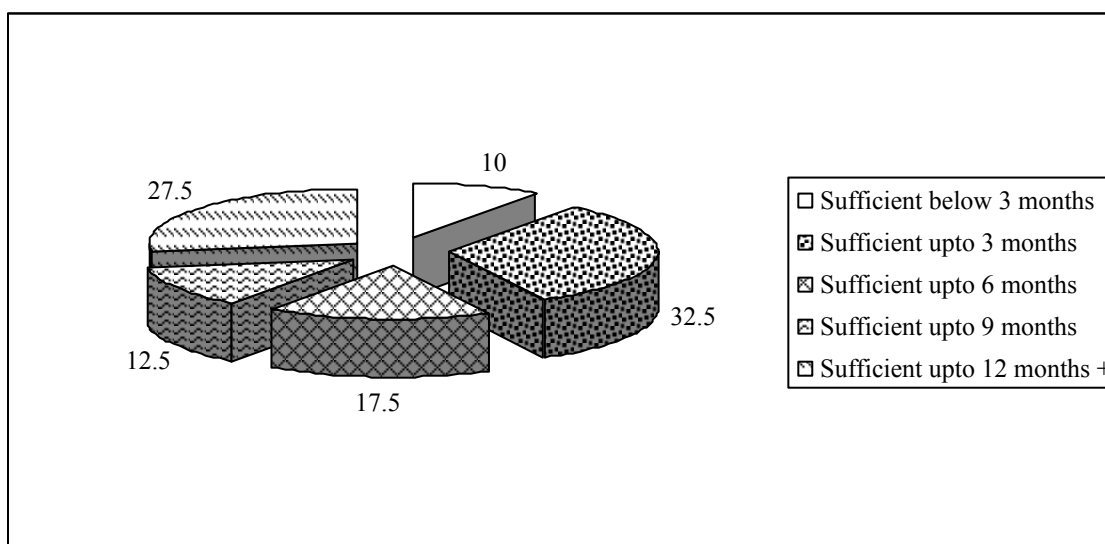

According to the above table 5.9 and figure No. 10 show that 11 households (27.5%) can solve their hand to mouth problem for entire year from their own food production and 29 households usually suffer from 'hand to mouth' existence. So, they have to buy food from their sources of earnings to meet their food deficiency problem.

CHAPTER - VI

INCOME GENERATING ACTIVITIES OF CFUGS

6.1 Introduction

Income generating activities have been initiated by the supporting of PAF grants. If there is potentiality of cash cropping (i.e. NTFs such as Amliso, turmeric, etc.) in the CF area, CFUGS can farm according to their own wishes. The main purpose of these activities is to raise additional income/employment opportunities to the poor as well as to increase the fund of CFUG. By the help of DFO, this funding support has been provided to the CFUGs in Ramechhap district.

According to the action plan of DFO there are 156 CFUGS involving in IGAs from FY 2000 to FY 2007 by the support of projects' grants. The DFO has provided Rs. 2,95,240 amount of project's grant to all the CFUGs. And 137 CFUGs have been performing IGAs from their own funds.

6.2 Income Generating Activities of Ramite CFUG

Mainly, the Ramite CFUG has been performing two types of inter-crop farming in the CFUG's area. They are as follows:

6.2.1 Amliso (Broom Grass) Farming

The botanical name of Amliso is *Amomum subulatum*. In the rural area, it can be used for two purposes. One purpose is to use Amliso for making broomstick. And another purpose is to use Amliso as a kind of fodder for livestock. It is ever green grass in winter season also. So, in winter it is very much useful for green grass. Therefore, people use to

plant this for fulfilling the needs of green grass and broomsticks. A piece of broomstick can be sold at Rs.15 by the people of study area. In this way two types of benefits have been achieved from this farming.

In Ramite CFUG, there have been planted 4000 pieces of seedlings on 20 ropanies land. For purchasing seedlings DFO has provided Rs. 4000 amount from the grant of NUKCFP in FY 2000. Now, the Amliso farming at Ramite started to produce Amliso. The general assembly of Ramite CFUG evaluates the wholesale value of total products of Amliso farming. At the time of the field survey of this dissertation research, the amount of tangible income collected from Amliso is Rs.1500; which is deposited in the fund of Ramite CFUG. The intangible benefits from Amliso are their use as fodder.

This Ramite CFUG has been making a plan for planting additional 3000 pieces of seedlings in FY 2000. To purchase these seedlings, CFP provided Rs.3000 through DFO. Hopefully, this implementation of this plan will benefit to households and CFUG of Ramite also.

6.2.2 Turmeric Farming

Turmeric is one of the inter-croppings of Ramite CFUG. This farming has been started by the participation of only 10 sampled HHs. Nearly, 5 ropanis land have been cultivated by these HHs very actively. In the starting period the seeds of turmeric are purchased from the amount of CFUG's fund. There are planted 27 kgs of seeds. Ramite CFUG has generated a substantial amount of income from this turmeric farming. The total production of turmeric in the FY 2006/07 is between 100 to 150 kgs. They deposited 10 percent of the total income to their fund. In addition 25 kg. of turmeric seeds are saved to cultivate again in the next season. The users of 8HHs have got good benefit from the farming of turmeric in the

CFUG. The remaining nearly 75/125 kgs., they divided equally for their own consumption.

6.2.3 Other Sources of Income for CFUG

1. Green-Ground Grass

This is a kind of source for earning income to the CFUG. When there is restriction of grazing for animal this grass has been grown up.

The CFUG area use to open for collecting grass from May to September. During this time the users use to collect 3-4 bhari of grass per day for their live stocks. Purji system (in which the normal price is paid so that the forest authority gives permission) has been applied for distributing grass to all HHs. For taking Purji Rs.10 is determined by committee's members. Then after, anyone of the users can carry out the grass during opening time. In FY 2007, there has been collected Rs.170 in the CFUG's fund.

2. Dry Grass (Khar)

This is a kind of grass specially used for making the roof of houses particularly, the users whose houses had not been made from tile or tin. The price of the production is determined by the general assembly of FUG. Simply, normal price is determined for the user of own FUG. Nearly 12 HHS are benefited from this production and collected 1760 rupees to the fund in FY 2007.

3. Fuel Wood

In Ramite CFUG fuel wood has been distributed equally to all HHS, Nearly one months of February the forest area is opened for cutting fuel wood. The members of committee distribute by measuring the fuel

wood with the help of Dori (rope of 4 meters.) All HHs receive 10 dories. In the FY 2007, Rs. 2090 have been collected in the fund.

4. Timber

This is also a source of income for the CFUG. If the users of this CF asked for wood for making their houses, they pay some amount to the CFUG. This also provides to users according to CFUG's rule.

In the FY 2007, there has been collected 2150 rupees for wood.

5. Fines and Penalties

In the case study, it is found that the user who break the rule of group and does not come to the work of forest development and management must be fixed.

Grazing animals are not allowed in CF area. If any body grazes their animals inside the forest, he will be fined. The rate of fine is Rs.100 per animal at first, Rs.200 in next chance and Rs.500 at third time respectively assembly of CFUG.

Similarly, cutting trees without permission of UGC is supposed to be illegal in this CF. In any body of FUG as well as outsides does this type of illegal work he must accept the penalty levied by the decision of UGC.

On the other side, the person who does not attend the work of forest development and management also will be fined. The general assembly of CFUG fixed Rs.100 for one day's fine.

In FY 2007, Rs.1550 amount collected to the CFUG's fund as fine.

6. Entry Fee

The person who is the inhabitant of Ramite-6 and interested to enter into the CFUG must pay some amount in the form of entry fee. This fee is collected according to the rule of CFUG.

In the FY 2007, there has been collected 1720 rupees in the funds.

7. Livestock

This is one of the most IGAs of FUG. CFUG's fund has been mobilized from this activities. According to committee's decision 10% rate of interest is determined for providing loan. Nearly, 40 HHs have been taken loans for buying pig (s/he), goat (she), buffalo(she) and cow/ox form selling the production of animals half of them, returned their loan and interest to the fund.

6.3 Sources of Income for Sampled Households

The main sources of income are agriculture and livestock for the sample households. From agriculture the some sampled HHs of both CFUGs we to cell cereals, vegetables etc. And some sampled HHs sell livestock's production for earning income. Some of other households use to sell their labour for earning income.

The main sources of income for sample HHs and the average prices of each item are shown as follow.

	Price (in Rs.)
1. Cereals	
Rice	35 per kg
Maize	22 per kg
Millet	20 per kg
Wheat	20 per kg
2. Vegetables	
Items	Price (in Rs.)
Potato	22 per kg
Cabbage	20 per kg
Cauliflower	25 per kg
Bean	18 per kg
Green vegetables(Gralic, onion, radish etc)	25 per kg
Turmeric	60 pre kg
Ginger	25 per kg
3. Livestock production	
Items	Price (in Rs.)
Milk	30 per liter
Ghee	235 per kg
Yogurt	30 per kg
Chicken	200 per kg
Baff	100 per kg
Pork	80 per kg
Mutton	300 pre kg
4. Others	
Items	Price (in Rs.)
Fuel wood	100 per Bhari 45 kg nearly
Wage labor	70 per day
Broom stick	15 per piece

Sources: Field Survey, 2010

The above mentioned items are the main sources of earning for sampled HHs in the study area. The sample households as well as other HHs have been exercising with above activities for earning income and to meet their hand to mouth existence.

6.4 Annual Income of the Sampled Household

The major sources of income for the people in the study area are agriculture and livestock for sampled households. But respondents feel uneasy to reveal their cash income. They do not keep any record of their income and expenditure. So it is very difficult to know about accurate annual cash income. The following of the households from various sources in 2002 and in 2009.

Table 6.1

Average Annual Income of Samples HHs in Ramite CFUG.

Annual Income (In Rupee)	No. of HHs in 2002	No. of HHs in 2009
2000-4000	15	0
4001-8000	12	6
8001-12000	6	11
12001-20000	5	16
20000	2	7
Total	40	40

Sources: Field Survey, 2010.

The table 6.4 shows that there were 15 households who have annual income between 2000-4000 in 2002 and no one households a annual income in 2009. 7 HHs have income greater than Rs.20000 in 2009. Majority of the households falls in the group of Rs.12000 to 20000 in 2009 where as in 2002 majority of to house holds fall in the group of having income less than Rs.8000.

CHAPTER VII

SUMMARY, CONCLUSION AND RECOMENDATONS

This chapter deals the major findings, conclusion and recommendation for the further study.

8.1 Sumary

- It is found in the study area that the Ramite CFUG has done a seminar of two days for making its a long term (10 years) vision. The main vision of this CFUG is to reduce poverty by improving livelihood of people through forestry programme. By the seminar the users have also known that without the development of 5 capital i.e. natural capital (knowledge, skill, awareness), physical capital(schools, roads, financial capital (income, earnings), social capital (customs, values and institution) at the same ratio these is no possibility to increase people's livelihoods.
- The forest condition is found good on the CFUGs. Plants are growing day by day. The greenery of forest gives an attractive scene from which people can take a kind of pleasure.
- The people, particularly, the major percentage of women are found illiterate in to study area. Due to the lack of education, the hesitate to involve in the users committees. But now the environment is changing women participation is also little satisfactory on assembly, seminar and different programmes which was not in the past days.

- The co-operation and co-ordination among the users have better. People's participation is active on every programme of forest. But some users are taking negligence for the forestry programme.
- Fund mobilization for IGAs is a model work of this CFUG. Paying interest at the rate for different types of IGAs from CFUGs fund.
- In Ramite CFUG the fuel wood has been provided equitably to the users on the basis of family size.
- NTFPs farming is a popular IGA of CFUGs seeing this popular work users of other neighboring CFUGS come to visit as a study Tour.
- NGOs, DFO, Projects are providing different types of training, study tour which can increase the users knowledge.
- The CFP is sustainable and is very significant to meet the needs of the villagers. This programme is quite effective in the feeling of people.
- Labour of the people is going to non profit activities and use to agriculture as a mass production and create a market and find out for grate income.
- The production system must be change to one production, one quality, one skilled one grant, one labour one but money market to sold the product.

8.2 Conclusion

The study concludes that the community forestry programme is very successful to improve forest condition which has been degrading day by day. FUG plays a vital role for the preservation of forest and management to provide forest products for the villagers.

The funding support given by projects for IGA to CFUGs have encouraged them to operate such activities. These activities help users to increase the size of fund.

Further more, this shows that the CFUGs have learnt new ideas of getting additional profit and income employment opportunities from their CF. They are using the waste land and improving the bio-diversity. So, the demand for IGAs by the people has been increasing day by day.

Although it has some problems but these are minor, these will be solved day by day with the help of different sectors like community, NGO, INGO, DFO, other project, etc. Lastly, CFUG start to involve poor, women and disadvantaged groups of people in the activities according to their interest and encourage them to take part in decision making processes. All the above facts show a prosperous future of CFP.

8.3 Recommendations

On the basis of findings of the study, the following points are recommended which may be useful for the programme.

- The technical knowledge, related to different types of NTFP management should be developed through training and field based practiced for FUGS, DFO staff and other service provides.
- Knowledge and skill derived from training and study tour be transferred with each other among to users.

- The position of women is backward in our society in all walks of life. In daily life they involve in different activities such as cooking food, collecting fire wood, cutting fodder for livestock, etc which are not counted as income generating work. So, the activities direct related to women should be carried out. So, it could encourage them to involve different kinds of programme related to CF.
- Participation of women, poor and disadvantaged groups in decision making should be encouraged through adequate representative in users committee.
- Market should be managed to NTFPS these should not be sold in broker's hands by the users, taking low price.
- NGO, Government and Local people should still be more active future development of CFP.
- Measures should be taken to the illiteracy through formal and non formal education such as adult literacy classes, child education by coordinating with government, NGOs and INGOs.

REFERENCES

- Bajracharya, D. (1983). *Fuel, Food and Forest: Dilemma in a Nepal*. Village World Development, Vol. 11, No. 2, U.K.
- CBS (1997). *Nepal Living Standard Survey Report*. 1996, Vol. 1 and 2, CBS/NPC, Secretarial HMG/N.
- CBS (2001). *Population Census*. Central Bureau of Statistics, Kathmandu, Nepal.
- D.D.C. (206a B.S.). *Ramechhap District Profile*. District Development Committee, Ramechhap District.
- Dahal, S.P. (1997). "Income Generating through Non-Timber Forest Products: Opportunities and Constraints Experience from the Koshi Hills" *A Discussion Paper*, (NUKCFP).
- DFID (1998). *Shaping Forest Management*, Department for International Development, London, U.K.
- Edwards, D.M. (1994). "Non-Timber Forest Products from Nepal: the Medicinal and Aromatic Plant Trade", *Occasional Paper*, Forest Research and Survey Center, Kathmandu, Nepal.
- Gilmor, A.D. and Fisher, R.J. (1991). *Villagers Forest and Foresters*. The Philosophy, Process and Practice in Community Forest in Nepal, Sahayogi Press, Kathmandu, Nepal.

- K.C., Dorna (1993). *Income Generating Activities of FUGs in the Hills* (HUKCFP).
- Kafle, Shanta (2000). *Hamro Samydayik Ban Ko Prakriya* (NUKCFP), programme Coordination Office, Kathmandu, Nepal.
- Kanel, K. (2006). *Current Status of Community Forestry in Nepal*. Retrieved from <http://www.forestrynepal.org>.
- Kayastha, B.P. (1993). *Elements of Community Forestry in Nepal*.
- LFP (2001). *An Introduction of Livelihoods and Forestry programme*. Coordination Office, Baluwatar, Kathmandu.
- LFP (2002). *Livelihoods and Forestry programme Prospects*. LFP Co-ordination Office, Baluwatar, Kathmandu.
- Maharjan, M.R. (1991). "Policy Implication for Equitable Cost and Benefit Sharing in Community Forest of Nepal". *Banko Jankari*, Vol. 12, No. 2, Kathmandu, DFRS.
- Mahat, J.B.S. (1987). "Forestry Farming Likage in the Maintains". *ICIMOD Occasional Paper*. No. 7, Kathmandu, Nepal.
- Minuting Book of Ramite CFUG (2007), *Ramite Community Forestry User Group in Namadi VDC*.
- MoF (2005). *The Economic Survey*. HMG/N Ministry of Finance, Kathmandu, Nepal.
- MOF, (2007). *The Economics Survey*. Ministry of Finance, Kathmandu, Nepal.
- NPC (1992). *The Eight Plan (1992-1997)*. HMG/N National Planning Commission, Kathmandu, Nepal.

- NPC (1998). *The Ninth Plan (1997-2002)*. HMG/N National Planning Commission, Kathmandu, Nepal.
- NPC (2002); *The Tenth Plan (2002-2007)*. HMG/N National Planning Commission, Kathmandu, Nepal.
- NPC (2007). *The Three Years Antanim Plan (2007-2010)*. Government of Nepal National Planning Commission, Kathmandu, Nepal.
- Prasai, Dharendra Raj (2000). *Some Aspects of Community Forestry in Nepal: A Case Study of Bhagawanthumki Community Forest, Kavreplanchwok District, Nepal*. A Dissertation Paper Submitted to Central Department of Economic, T.U. Kirtipur.
- Ramite Ban Ko Bidhan 2049 B.C.*; Ramite Community Forestry User Group, Namadi VDC.
- Rana, Saurab Bickram (1996). *Some Aspects of Ghowany Khola Community Forestry, Walling VDC*. A Dissertation Paper Submitted to Central Department of Economics, T.U., Kirtipur.
- Regmi, M.C. (1978). *Land Tenure and Taxation in Nepal*. Bibliotheca Himalayica, Series / Vol. 26, Ratna Pustak Bhandar, Kathmandu, Nepal.
- Singh, B.K. (1998). "Community Forest in Nepal, Gradual Move from Subsistence to Benefits Sector of Economy." *Banko Jankari*, vol. 8, No. 1, Kathmandu, DFRS.
- Upreti, L.P. (2000). *Situation Analysis of Community Forestry User Groups: Case Studies from Dang District Samaj Journal of Sociology/Anthropology*. pp. 30-40. Department of

Sociology/Anthropology, Trichandra Multiple Campus, Tribhuvan University.

Questionnaire on IGAs of CFUGs

1. Household Description

Name:

Sex:

Age:

Ward No.:

Religion:

Education

Main occupation:

1.1 Family Description

S.N.	Name	Age	Sex		Educational status 1, 2, 3, 4, 5	Occupation
			Female	Male		
1						
2						
3						
4						

Educational Status

1 = Illiterate

2 = Literate (Either formal or non formal education)

3 = Primary

4 = Secondary

5 = Higher secondary

2 Do you have own land ?

(a) Yes

(b) No

If yes, how much (In ropani)

(a) Bari

(b) Khet

3 Do you cultivate on your land ?

(a) Yes

(b) No

If no by whom is it cultivated ?

- 4 How much do you produce from your land ?
 (a) Cereal.....quantity
 (b) Cash crops.....quantity
- 5 How many animals do you have ?
 (a) Buffalo (b) Cow/Ox (c) Pig (d) Goat (e) Chicken
- 6 Do you sell your livestock production ?
 Milk..... Ghee..... Meat.....
 Egg..... Curd.....
- 7 How do you feed the animals ?
 (a) Stall feeding () (b) Free grazing () (c) Supervised grazing ()
- 8 From where do you get the fodder ?
 (a) Private forest () (b) Community forest () (c) Others ()
- 9 In which time (months) do you get fodder from CF ?
- 10 Who collects fodder in your family ?
 (a) Male () (b) Female () (c) Children ()
- 11 Do you get enough fodder to feed your animals ?
 (a) Yes () (b) No ()
- 12 From where do you get leaf liter for your live stock ?
 (a) Private forest () (b) Community forest ()
 (c) Government forest ()
- 13 Is fire wood the main sources of energy ?
 (a) Yes (b) No
- 14 What are the other sources of energy ?

- (a) Kerosene () (b) Gobar Gas () (c) Solar Energy ()
- (d) Other

* 15 Has CF played an important role in distributing fire wood ?
 (a) Yes () (b) No ()
 If no, what is the reason behind it ?

16 Do you sell fire wood ?
 (a) Yes () (b) No ()

* 17 What types of IGAs are in your CF ?
 (a) Please mention

* 18 How the production of IGAs is sold ?

* 19 What is the future plan of your CFGs for IGAs ?
 Please mention

* 20 Is there any problem regarding the community forestry progamme
 (a) Yes () (b) No ()

21 Do you get other benefits from community forestry rather than fuel
 wood and fodder ?
 (a) Yes () (b) No ()

22 How much money do you earn in a year ? Please mention the total
 money income of this year (2008) and five years ago (2003).

Year	Income
2003	Rs.
2008	Rs.

23 Please, tell your sources of earnings.

(a) (b) (c) (d)

24 Have you taken the loan from CFUG fund ?

(a) Yes () (b) No ()

25 How much do you pay the interest rate in a year ?

26 What is your opinion about CF programmes ?

(a) Very beneficial () (b) Beneficial/good ()
 (c) Not very important () (d) Not beneficial ()

27 Is CF programme most necessary and important ?

(a) Yes () (b) No ()

28 Do you expect any help from government and non governmental organization ?

(a) Yes () (b) No ()

29 What is your involvement in following activities

Activities	High	Moderate	Low
Firewood collection			
Fodder collection			
Grazing			

30 How did you form forest user group committee ?

(a) Election () (b) Others ()

31 Are you satisfied with community forest programme ?

If yes, why ?

If no, why ?

Note: * Only for the CF members.