

**TRIBHUVAN UNIVERSITY
INSTITUTE OF ENGINEERING
PULCHOWK CAMPUS**

THESIS NO.: M-411-MSREE-2020-2026

**Transitioning from LPG Cooking to Commercial Electric Induction Cooking: A
Case Study of Sundarijal Arsenal Barrack, Kathmandu, Nepal**

by

Nabin Kumar Mandal

A THESIS

**SUBMITTED TO THE DEPARTMENT OF MECHANICAL AND AEROSPACE ENGINEERING
IN PARTIAL FULFILLMENT OF THE REQUIREMENTS FOR THE DEGREE OF
MASTER OF SCIENCE IN RENEWABLE ENERGY ENGINEERING**

DEPARTMENT OF MECHANICAL AND AEROSPACE ENGINEERING

LALITPUR, NEPAL

January, 2026



**TRIBHUVAN UNIVERSITY
INSTITUTE OF ENGINEERING
PULCHOWK CAMPUS**

THESIS NO.: M-411-MSREE-2020-2026

**Transitioning from LPG Cooking to Commercial Electric Induction Cooking: A
Case Study of Sundarijal Arsenal Barrack, Kathmandu, Nepal**

by

Nabin Kumar Mandal

A THESIS

SUBMITTED TO THE DEPARTMENT OF MECHANICAL AND AEROSPACE ENGINEERING
IN PARTIAL FULFILLMENT OF THE REQUIREMENTS FOR THE DEGREE OF
MASTER OF SCIENCE IN RENEWABLE ENERGY ENGINEERING

DEPARTMENT OF MECHANICAL AND AEROSPACE ENGINEERING

LALITPUR, NEPAL

January, 2026

COPYRIGHT

The author has agreed that the library, Department of Mechanical and Aerospace Engineering, Pulchowk Campus, Institute of Engineering may make this thesis freely available for inspection. Moreover, the author has agreed that permission for extensive copying of this thesis for scholarly purposes may be granted by the professor(s) who supervised the work recorded herein or, in their absence, by the Head of the Department wherein the thesis was done. It is understood that the recognition will be given to the author of this thesis and to the Department of Mechanical and Aerospace Engineering, Pulchowk Campus, Institute of Engineering in any use of the material of the thesis. Copying or publication or the other use of this thesis for financial gain without approval of the Department of Mechanical and Aerospace Engineering, Pulchowk Campus, Institute of Engineering and author's written permission is prohibited.

Request for permission to copy or to make any other use of the material in this thesis in whole or in part should be addressed to:

Head

Department of Mechanical and Aerospace Engineering

Pulchowk Campus, Institute of Engineering

Lalitpur, Nepal

**TRIBHUVAN UNIVERSITY
INSTITUTE OF ENGINEERING
PULCHOWK CAMPUS
DEPARTMENT OF MECHANICAL AND AEROSPACE ENGINEERING**

The undersigned certify that they have read and recommended to the Institute of Engineering for acceptance, a thesis entitled **“Transitioning from LPG Cooking to Commercial Electric Induction Cooking: A Case Study of Sundarijal Arsenal Barrack, Kathmandu, Nepal”** submitted by Nabin Kumar Mandal in partial fulfillment of the requirements for the Degree of Master of Science in Renewable Energy Engineering.



Supervisor, Dr. Ajay Kumar Jha

Associate Professor,

Department of Mechanical and Aerospace Engineering,
Pulchowk Campus



External Examiner, Er. Sirapa Shrestha

Lecturer,

Department of Mechanical Engineering, Kathmandu
University





Committee Chairperson, Dr. Sudip Bhattarai

Head, Department of Mechanical and Aerospace
Engineering, Pulchowk Campus

Date: January 26, 2026

ABSTRACT

This study presents a practical framework for transitioning cooking practice at the Sundarijal Arsenal Barrack from LPG to electric induction cooking. The transition is motivated by rising LPG prices, dependence on imported LPG, and the increasing availability of clean, domestically generated electricity. Large institutional kitchens such as army barracks consume substantial amounts of fuel daily, so improving cooking efficiency can result in significant financial and environmental benefits. The study first analyzes the existing LPG-based cooking system. Data were collected through field visits, direct observations, and interviews with kitchen staff and technical personnel. The barrack serves approximately 252 personnel daily and consumes about 5,296.6 kg of LPG per year. This provides a total energy input of 67,690.55 kWh annually. However, due to the low thermal efficiency of LPG stoves, only around 36% of this energy is effectively utilized for cooking. Consequently, the energy consumption per person is high, at 268.6 kWh per year. To replace LPG cooking, the required capacity of commercial induction cooktops and the existing electrical infrastructure were assessed. The analysis shows that an induction capacity of about 25 kW is sufficient and can be supported by the available three-phase electricity supply. The proposed induction system consumes around 85 kWh per day, or 31,025 kWh per year, assuming two cooking sessions per day. This reduces energy consumption per person to 123.11 kWh per year, which is less than half of the LPG-based system. A financial analysis comparing LPG and induction cooking shows strong economic viability. The barrack currently spends approximately NPR 7,12,430 per year on LPG, while the annual electricity cost for induction cooking is about NPR 3,80,056.25. The total investment cost is around NPR 11,20,000, with a simple payback period of 3.75 years, an internal rate of return of 23.425%, and a net present value of NPR 7,15,835.36 over a time period of ten years. Environmentally, the transition reduces CO₂ emissions by about 15.8 tonnes per year, equivalent to 62.7 kg per person annually. Overall, the study confirms that induction cooking is a technically feasible, financially viable, and environmentally sustainable primary cooking solution for the Sundarijal Arsenal barrack as well as for the other Nepali Army units and is also suitable for large commercial kitchens like security personnel barracks, hostel, banquet, hotel, etc.

ACKNOWLEDGEMENT

The successful completion of this research was made possible through the combined support of my Supervisor, Department, University's resources and other external partners who contributed both directly and indirectly. I sincerely appreciate the time, guidance, and effort of everyone involved.

First and foremost, I would like to express my deep gratitude to my supervisor, Associate Prof. Dr. Ajay Kumar Jha from the Department of Mechanical and Aerospace Engineering, Pulchowk Campus, for his constant guidance and unwavering support throughout the research journey. His encouraging attitude and belief with both interest and patience changed the way I see the research and made the whole process look easier and meaningful.

I am also very grateful to Sundarijal Arsenal Barrack team for their assistance and support during this research period and I also want to convey my heartfelt appreciation to the Commandant of the Sundarijal Arsenal barrack for giving me the opportunity to work in their premises through the entire study period.

My heartfelt gratitude goes to all my family members, especially mother, father and my brother and sister for their endless support and encouragement.

TABLE OF CONTENTS

COPYRIGHT	ii
ABSTRACT	iv
ACKNOWLEDGEMENT	v
LIST OF TABLES	viii
LIST OF FIGURES	ix
LIST OF ACRONYMS AND ABBREVIATIONS	x
CHAPTER ONE: INTRODUCTION	1
1.1 Background.....	1
1.2 Historical Overview of Cooking Practices in the Nepali Army.....	7
1.3 Problem statement.....	9
1.4 Objectives.....	11
1.4.1 Main objective.....	11
1.4.2 Specific Objectives.....	11
1.5 Scope and limitations of work.....	11
CHAPTER TWO: LITERATURE REVIEW	12
2.1 Cooking Practices in Nepal.....	12
2.2 Clean Cooking Standards in Nepal.....	14
2.3 Cooking Technology in Nepal.....	17
CHAPTER THREE: METHODOLOGY	22
3.1 Study Area.....	23
3.2 Data Collection.....	23
3.3 Technical Analysis.....	23
3.4 Financial Performance Parameters.....	25
3.4.1 Simple Payback Period.....	25
3.4.2 Net Present Value (NPV).....	26
3.4.3 Internal Rate of Return (IRR).....	26
3.5 Environmental Analysis.....	27
3.6 Comparison with the existing LPG cooking system.....	27
CHAPTER FOUR: RESULTS AND DISCUSSION	28
4.1 Technical Analysis.....	28
4.1.1 Annual LPG Consumption.....	28
4.1.2 Thermal Efficiency using Water Boiling Test.....	28
4.1.3 Useful Energy Output from LPG.....	34
4.1.4 Total Energy Consumption in the Barrack for Cooking.....	34

4.1.5 Total Capacity of Commercial Induction Cooktop required	35
4.1.6 Electrical Load distribution in the barrack	35
4.1.7 Barrack Population	39
4.2 Financial Analysis.....	40
4.3 Environmental Analysis.....	41
4.4 Comparison with the existing LPG cooking system.....	42
4.4.1 Technical Comparison.....	42
4.4.2 Financial Comparison.....	44
4.4.3 Environmental Comparison.....	45
CHAPTER FIVE: CONCLUSIONS AND RECOMMENDATIONS	47
5.1 Conclusions.....	47
5.2 Recommendations.....	48
REFERENCES.....	50
APPENDICES A: EXPERIMENT SETUP	52
APPENDICES B: DATA SHEET	53
APPENDICES C: TECHNICAL SPECIFICATION OF THE COMMERCIAL ELECTRIC INDUCTION COOKTOP WITH VARIOUS UTENSILS	54
APPENDICES D: ELECTRICITY BILL OF SUNDARIJAL ARSENAL FOR KARTIK/2082	58
APPENDICES E: INVITATION FOR BIDS FOR THE PROCUREMENT OF “ELECTRIC STOVE WITH VARIOUS UTENSIL”	59

LIST OF TABLES

Table 2.1: Cumulative Number of Households Adopting Different Primary Cooking Options in the Ambitious E-cooking Scenario	12
Table 2.2: Levels of Cookstoves Performance and Clean Cooking Technologies in Nepal	15
Table 4.1: Thermal efficiency of LPG cooking stove	33
Table 4.2: Total Energy Consumption in the Barrack for Cooking	35
Table 4.3: Transformer Rating	36
Table 4.4: List of Cooking Utensils including Induction Stoves.....	37
Table 4.5: Financial Analysis	41
Table 4.6: Calculation of CO ₂ Equivalent from LPG savings as well the total cost savings.....	42

LIST OF FIGURES

Figure 1.1: Global Access to Clean Cooking Fuels.....	2
Figure 1.2: Sectoral Energy Consumption for FY 2079/80.....	2
Figure 1.3: Energy Consumption of Residential Sector for FY 2079/80	3
Figure 1.4: Import of LPG in Different Fiscal Years.....	4
Figure 1.5: Comparison of Energy Consumption.....	5
Figure 1.6: Important SDG 7 Energy Goals and Progress.....	6
Figure 1.7: Cooking by LPG Stoves in the Nepali Army	8
Figure 1.8: Use of Bakery Machine and Rice Steamer in the Nepali Army.....	8
Figure 2.1: Percentage Share of Households using Different Primary Cooking Option in the Ambitious E-Cooking Scenario	13
Figure 2.2: Hierarchy of Cooking Technologies	16
Figure 2.3: Overall Massage of Cooking Technologies	17
Figure 3.1: Research Methodology Flowchart.....	22
Figure 4.1: LPG Consumption Chart.....	28
Figure 4.2: LPG burner used for cooking in Sundarijal Arsenal barrack.....	29
Figure 4.3: Thermal efficiency comparison of burners in different high power phase.....	33
Figure 4.4: Electrical load distribution chart of Sundarijal Arsenal barrack.....	38
Figure 4.5: Barrack Population over 10 years.....	39
Figure 4.6: Energy per capita per year (kWh/year) for both LPG and Induction cooking system.....	43
Figure 4.7: Cost per capita for both LPG and Induction cooking system.....	44
Figure 4.8: CO ₂ emission reduction per capita per year (NPR/year) for both LPG and Induction cooking system.....	46
Figure 4.9: Cost savings from CO ₂ emission reduction per capita per year (kg) for both LPG and Induction cooking system.....	46

LIST OF ACRONYMS AND ABBREVIATIONS

LPG	Liquified Petroleum Gas
WHO	World Health Organization
HAP	Household Air Pollution
ESR	Energy Synopsis Report
WECS	Water and Energy Commission Secretariat
NOC	Nepal Oil Corporation
NFTS	Nepal Foreign Trade Statistics
GoN	Government of Nepal
MW	Mega Watt
SDG	Sustainable Development Goal
MoEWRI	Ministry of Energy, Water Resources, and Irrigation
DALY	Disability-Adjusted Life Years
AEPC	Alternative Energy Promotion Center
WBT	Water Boiling Test
ISO	International Organization for Standardization
ICS	Improved Cook Stoves
kW	kilo Watt
kWh	kilo Watt hour

CHAPTER ONE: INTRODUCTION

1.1 Background

Nepali Army is one of the oldest security forces having a glorious and pioneering history. Nepali Army has a pivotal role in safeguarding sovereignty and territorial integrity and safeguarding the nation from external threats ensuring the fulfillment of Nepal's core national interests. After the establishment of democracy, the government began providing ration facilities to the Nepal Army in 1951. Nowadays, these rations are categorized into five main groups: dry rations, meat, fresh food, dairy products, and cooking fuel (LPG). A key element in maintaining operational readiness and the physical fitness of soldiers is the regular provision of nutritious and safe meals. However, traditional cooking practices in Nepal, particularly in institutional settings, often depend on biomass fuels and inefficient stoves, which pose significant health risks, contribute to environmental degradation, and expose kitchen staff and soldiers to harmful indoor air pollution(Karmacharya, 2023).

According to WHO (2022), 2.1 billion people worldwide still remain without access to clean cooking as of 2022. The use of inefficient, polluting fuels and technologies is a health risk and a major contributor to diseases and deaths, particularly for women and children in low- and middle-income countries. It is estimated that approximately 74% of the global population were primarily using clean fuels and technologies for cooking. From 2010-2022, the rate of access to clean cooking fuels and technologies only increased by about 1.4% per year.

Household air pollution was responsible for an estimated 3.2 million deaths per year in 2020, including over 2,37,000 deaths of children under the age of 5. HAP exposure leads to noncommunicable diseases including stroke, ischaemic heart disease, chronic obstructive pulmonary disease (COPD) and lung cancer. It is essential to expand use of clean fuels and technologies to reduce household air pollution and protect health. These include solar, electricity, biogas, liquefied petroleum gas (LPG), natural gas, alcohol fuels, as well as biomass stoves that meet the emission targets in the WHO Guidelines (WHO,2024).

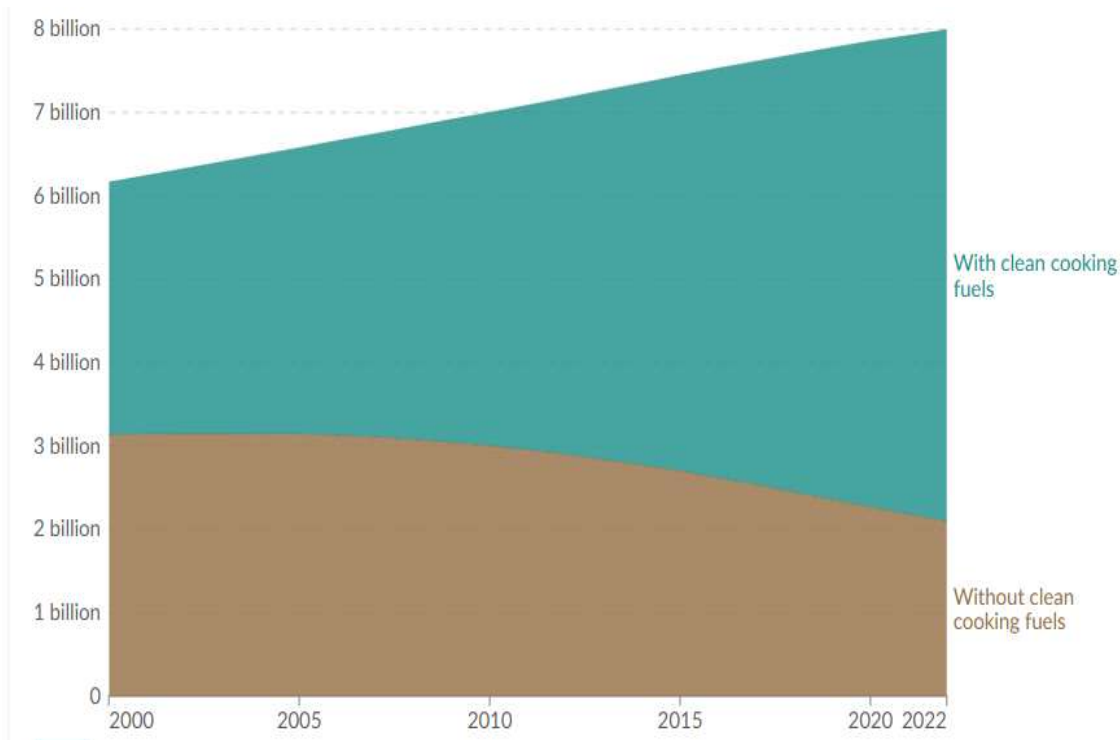

Figure 1.1. Global Access To Clean Cooking Fuels (WHO, 2025)

In Nepal, the residential sector remains the highest energy consuming sector, accounting for 60.75%. Fuelwood still dominates residential energy consumption at 79.52%. Other sources of energy in residential sector are LPG 5.62%, electricity 4.99%, biogas 3.31%, animal waste 2.93%, agriculture residues 2.75%, solar 0.68%, kerosene 0.03%, coal 0.01% and wind 0.0053% (WECS, 2024). Figure 1.2 shows the sectoral energy consumption for FY 2079/80 while figure 1.3 shows the energy consumption of residential sector for FY 2079/80 (WECS, 2024).

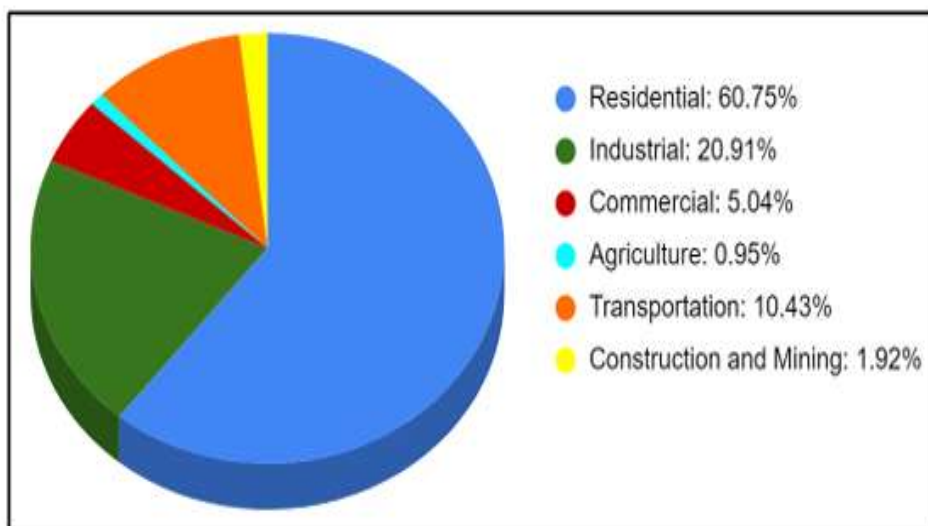

Figure 1.2. Sectoral Energy Consumption for FY 2079/80

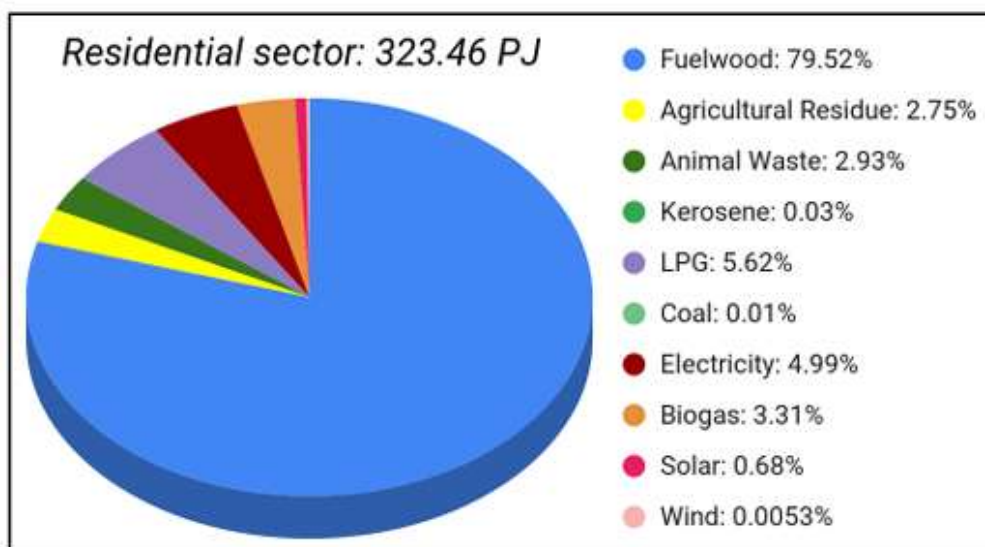

Figure 1.3. Energy Consumption of Residential Sector for FY 2079/80

The Energy Sector Synopsis Report, 2024 published by Water and Energy Commission Secretariat (WECS) illustrates the energy consumption mix in Nepal’s residential sector, totaling 323.46 petajoules (PJ). It reveals a heavy reliance on traditional biomass fuels, with fuelwood accounting for the vast majority at 79.52%. Other biomass sources such as agricultural residue (2.75%) and animal waste (2.93%) also contribute to household energy needs. In contrast, modern and cleaner energy sources remain limited: liquefied petroleum gas (LPG) makes up only 5.62%, electricity 4.99%, and biogas 3.31%. Renewable sources like solar (0.68%) and wind (0.0053%) have minimal presence, while kerosene (0.03%) and coal (0.01%) are almost negligible. This distribution highlights the urgent need to promote cleaner and more sustainable cooking practices in Nepal stepping towards modern energy access.

More than half (51%) of the total households in the country usually use firewood as the main source of fuel for cooking. Other main sources of fuel for cooking are LPG 44.3%, cow-dung 2.9%, biogas 1.2%, electricity 0.5%, kerosene 0.05% and other 0.1% of the total households(National Statistics Office, 2023). Firewood serves as the primary cooking fuel for nearly two-thirds of households (64 percent), followed by LPG at 21.03 percent and cow dung at 10.38 percent. Additionally, bio-gas and kerosene are utilized by 2.43 and 1.03 percent of homes, respectively. Conversely, electricity remains the least common energy source, with a minimal 0.08 percent adoption rate for domestic cooking (National Planning Commission, 2012).

By 2021, although this figure had dropped to just over half (51%), firewood remained the most common fuel. Over these two decades, the most notable change is the dramatic rise in the use of LPG (liquefied petroleum gas), which jumped from 21.03% in 2011 to 44.3% in 2021, making it almost as popular as firewood. Electricity use for cooking, while still very low, has increased slightly, but remains below 1% of households. Both WECS and census reports show that clean cooking technology is still challenging in Nepal.

The import of LPG gas in different fiscal years in Nepal as per the data of Nepal Oil Corporation (NOC) and Nepal Foreign Trade Statistics (NFTS, FY 2079/80) is shown below.

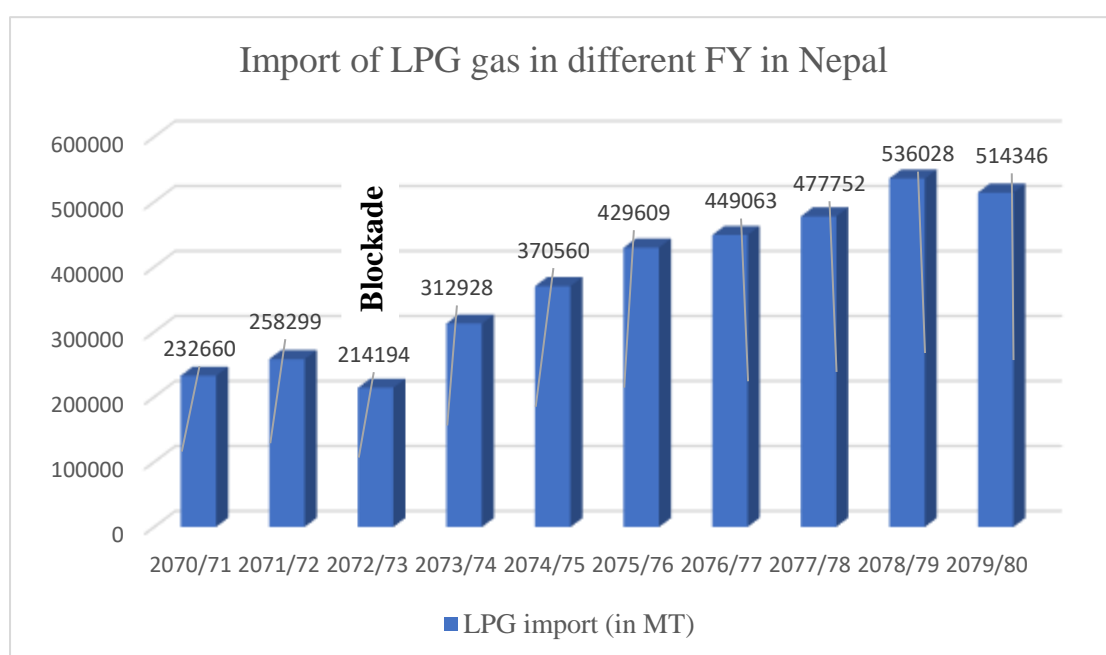

Figure 1.4. Import of LPG in Different Fiscal Years (NOC, NFTS)

The chart provides the imports of the LPG (liquefied petroleum gas) to Nepal in the various fiscal years as noted by the Nepal Oil Corporation (NOC) and Nepal foreign trade statistics (NFTS). As data indicate, there was an evident trend of raising LPG imports, which began with 232,660 metric tons in 2070/71 and continued to raise almost continuously approaching 536,028 metric tons in the upcoming years of 2078/79, and slid in 2079/80 to 514,341 metric tons. This gradual rise underlines the adoption of LPG as the most important energy source of cooking and various commercial and industrial purposes.

According to NFTS (FY 2079/80), LPG gas ranked 3rd in the most imported commodities in the fiscal year 2079/80. However, the imports decreased by 4.04% compared to the fiscal year 2078/79 and the total amount also decreased from 65.56 billion to 58.16 billion.

Fuel Type	000 GJ		Percentage Change
	2078/79	2079/80	
Traditional	410,678.59	340,039.74	-17.20%
Wood	374,562.95	304,625.30	-18.67%
Agriculture Residue	17,965.50	25623.22	42.62%
Animal Dung	18,150.14	9,791.23	-46.05%
Commercial	181,406.91	137,383.84	-24.27%
Coal	58,148.22	34,015.89	-41.50%
Petroleum Products ¹⁰	123,258.69	103,367.96	-16.14%
Electricity	31,766.40	38,495.00	21.18%
Renewable	16113.884	16,499.43	2.39%
Total	639,965.79	532,418.01	-16.81%

Figure 1.5. Comparison of Energy Consumption (WECS, 2024)

The country's shift towards renewable and alternative energy sources has significantly reduced the reliance on fossil fuels. Renewable energy, particularly hydropower, now plays a crucial role in meeting the energy demands of production and manufacturing, thereby reducing the consumption of coal and petroleum.

Nepal has abundant hydropower potential to meet the growing energy need. Electricity generated from hydropower is clean, sustainable and environmentally friendly. In this regard, providing clean cooking facilities to both rural and urban areas through electricity could play a major role in reducing indoor emissions and transitioning to domestically available and modern sustainable fuel in Nepal. An estimated 68% of the

urban areas rely on LPG, followed by biomass. In rural areas, almost 90% of the population depends on solid fuels. However, the penetration of electricity is growing in both urban and rural areas. This has provided Nepal the opportunity to transition from LPG/solid fuels to electricity. This will help reduce negative health impacts of solid fuel cooking, improve livelihood as well as ensure energy security in the long run (Kafle et al., 2019).

Second Nationally Determined Contribution, GoN, 2020 reports ensures that 25% of households use electric stoves as their primary mode of cooking by 2030, installing 5,00,000 improved cookstoves in rural areas by 2025, and installing 2,00,000 household biogas plants and 500 large-scale biogas plants by 2025. Similarly, it includes expanding clean energy generation from approximately 1,400 MW to 15,000 MW and 15% of the total energy demand is supplied from clean energy sources by 2030 and achieve net-zero greenhouse gas emission by 2050 (GoN, 2020).

The progress of Nepal in achieving SDG-7 goals is shown in the figure 1.6.

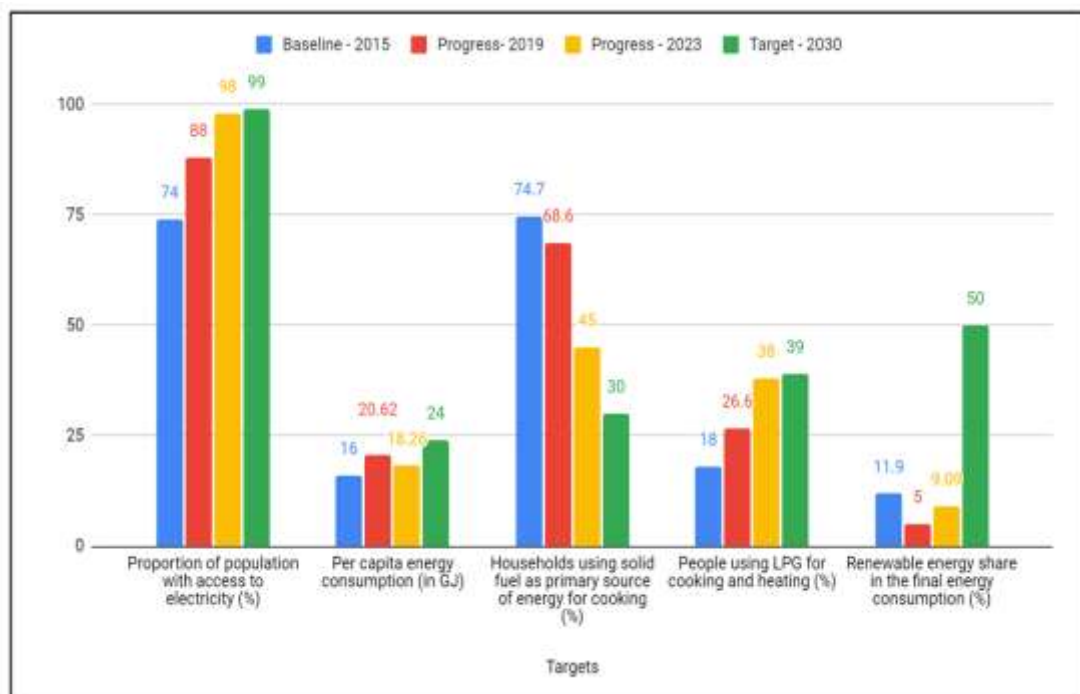

Figure 1.6. Important SDG 7 Energy Goals and Progress, Energy Synopsis 2023, 16th Plan (WECS, 2024)

Despite the progress of Nepal nearing the targets set on some important SDG targets, renewable energy share in the final energy consumption still requires significant time

and effort from all levels (public, private, as well as government) to meet the targets by year 2030.

Therefore, bridging the gap between energy access, energy mix and clean cooking practices, especially in security institutions like the Nepali Army where improving health, energy security, and environmental sustainability are paramount, Nepal has an opportunity to transition to cleaner and sustainable energy sources.

1.2 Historical Overview of Cooking Practices in the Nepali Army

The Nepali Army, as one of the essential pillars of the nation, has continually adapted its operational and logistical methods to meet the needs of its personnel. One area that has evolved significantly over time is the cooking practices within the army, particularly concerning the types of fuels and methods used for preparing meals for the soldiers. The evolution of cooking practices within the Nepali Army has been influenced by various factors, including the availability of resources, technological advancements, and the broader socio-economic and environmental conditions of the country.

The journey of cooking fuel usage in the Nepali Army began with wood, the most common source of fuel in the past. Wood was abundantly available, particularly in rural and forested areas, and its use was integral to military operations where mobility and sustainability were essential. However, over time, Nepal Army, like many other organizations worldwide, faces the challenge of reducing its carbon footprint and environmental challenges, thus promoting sustainable practices.

In 2006, recognizing the unsustainable nature of wood as a primary fuel source, the Nepali Army transitioned to kerosene. This shift was aimed at reducing the environmental strain caused by deforestation and the associated long-term impacts on local ecosystems. Kerosene, being a more efficient and cleaner burning fuel, allowed for faster cooking times and reduced dependency on wood. However, despite the benefits, kerosene presented its own set of challenges, such as volatility, pollution, and increased logistical costs due to its import.



Figure 1.7. Cooking by LPG Stoves in the Nepali Army

By 2015, the Nepali Army moved towards LPG as the primary cooking fuel. This transition was driven by the desire for a cleaner, more efficient, and safer cooking option. LPG became increasingly popular due to its high calorific value, convenience, and ease of storage and transport. However, while LPG provided immediate benefits, it also introduced new challenges as Nepali Army is heavily relying on imported LPG.



Figure 1.8. Use of Bakery Machine and Rice Steamer in the Nepali Army

Since 2021, the Nepali Army has introduced electric bakery machines and rice steamers as part of its e-cooking initiative. With the application of electric bakery machines and rice steamers in its mess halls, the Nepali Army can cook bread, pastries and steamed rice more regularly and safely. The use of these electric appliances indicates the interest of the Army in serving its functions more efficiently, a safe working environment to benefit the soldiers, and mostly prioritizing energy security. With this, the Nepali Army

has attempted to align the national clean energy policies and become a role model in sustainable cooking practices in the security agencies of Nepal.

1.3 Problem statement

The increasing usage of electricity, however, has led to an increase in the per capita electricity consumption value and subsequently increased the residential electricity consumption per household. The overall electricity consumption of Nepal reached about 370 kWh per capita (WECS, 2024). This figure remains significantly lower than global averages compared to India's per capita electricity consumption stands at approximately 1,200 kWh, while China's exceeds 5,000 kWh, and the United States surpasses 12,000 kWh (Pandit et al., 2023). However, the Ministry of Energy, Water Resources, and Irrigation (MoEWRI) has set an ambitious target to increase Nepal's per capita electricity consumption to 700 kWh in the next five years and 1,500 kWh within ten years (WECS, 2024).

In many cases, people burn firewood on inefficient traditional cookstoves. This causes high levels of household air pollution (HAP). It leads to over 22,500 premature deaths each year and a loss of more than 710,000 disability-adjusted life years (DALYs) annually. Electric cooking (e-cooking) is becoming a popular choice in Nepal to reduce HAP, improve public health, and cut dependence on imported LPG. With better electricity supply now and expected surplus in the future, e-cooking is slowly gaining attention. It is viewed as key for long-term use of Nepal's own hydroelectric resources (Practical Action, 2021).

Despite Nepal's abundant hydropower potential and increasing electricity access nationally, only 0.5% of households cook with electricity (National Statistics Office, 2023). This indicates that the adoption of electric cooking, particularly induction stoves, remains limited due to unreliable electricity supply, low voltage, high initial costs and lack of awareness.

This reliance on traditional and LPG-based cooking hinders public safe cooking improvements, energy security, and alignment with national clean energy goals, such as the Second Nationally Determined Contribution (NDC) target of 25% household e-cooking adoption by 2030, as well as the international UN SDGs, especially SDG 7

(Affordable and Clean Energy) fulfilling the specific target of increasing access to electricity to 99%, reducing fuelwood usage to 30%, and limiting LPG usage to in 2030. However, Nepal has only achieved to target of 94% of Nepal's population has access to electricity, 6.9% of the total population has access to renewable energy, 92.2% of households use electricity as the main source of lighting, 51% of households use fuelwood for cooking and 44.3% of households use LPG for cooking.

Cooking practices in Nepal are at a crossroads: traditional biomass cooking persists on a large scale in rural areas, LPG has become the norm in urban areas, and electric cooking is only emerging. This presents both a challenge and an opportunity – the challenge of addressing cooking habits and infrastructure gaps, and the opportunity to leapfrog to clean cooking given Nepal’s expanding renewable electricity generation.

The Nepali Army, a critical institution with 90,000+ active personnel, spends approximately NPR 552 million annually on imported LPG for cooking (LPG scale per person per day 0.125kg, with 90,000+ active personnel), exposing it to supply chain vulnerabilities, geopolitical risks, and economic burdens. The gradual transition to electric cooking within the Nepali Army has been further strengthened through the implementation of a pilot induction cooking project. Based on feedback highlighting issues such as burnt meals from high power settings and uneven heat distribution due to smaller coil diameters, the shift from LPG to induction cooking offers a practical improvement. By adopting this cleaner and more efficient technology, the Nepali Army can serve as a leading example of induction cooking not as a backup, but as a primary source of cooking.

However, the absence of comprehensive research on the energy consumption patterns and transition potential within the Nepali Army further complicates the development of sustainable cooking practices, necessitating an evaluation of the feasibility, efficiency, and cost-effectiveness of transitioning to electric induction cooking to address these multifaceted challenges.

1.4 Objectives

1.4.1 Main objective

The main objective of this study is:

- To assess the feasibility and impact of transitioning from LPG cooking to electric induction cooking in the Sundarijal Arsenal army barrack, Kathmandu, Nepal.

1.4.2 Specific Objectives

The specific objectives of this study are:

- To find the current energy consumption for cooking in Sundarijal Arsenal barrack.
- To conduct experimental testing and calculate the efficiency of existing LPG cooking system.
- To find the capacity of commercial electric induction cooktop required to replace LPG.
- To analyze the electrical load distribution in the barrack premises as well as the electrical infrastructure suitability after the installation of the induction cooking system.
- To carry out the technical, financial and environmental analysis for transitioning from LPG cooking to induction cooking.
- To perform the technical, financial and environmental comparison with the existing LPG cooking system.

1.5 Scope and limitations of work

- Site specific results may not be fully applicable to other locations.
- Challenges in quantifying the non-monetary environmental benefits.
- Power outages may disrupt the cooking process.

CHAPTER TWO: LITERATURE REVIEW

2.1 Cooking Practices in Nepal

The cumulative number of households that adopt various primary cooking options from 2020 to 2030 in the ambitious e-cooking scenario is estimated while also taking into account population growth as shown in the table 2.1.

Cooking Options	2020	2022	2023	2025	2028	2030
Electric cookstove	373,605	627,808	759,797	1,060,090	1,500,726	1,853,146
LPG cookstove	3,175,640	3,190,288	3,195,042	3,282,859	3,270,451	335,662
Biogas cookstove	684,942	807,181	870,194	1,025,893	1,104,308	1,186,013
ICS T3+	74,721	224,217	305,217	478,750	665,416	815,384
ICS T2	996,279	794,369	688,363	478,750	198,209	0
TCS	921,558	762,338	675,375	512,947	339,787	222,378
Total households	6,226,745	6,406,200	6,493,988	6,839,289	7,078,898	7,412,582

Table 2.1. Cumulative Number of Households Adopting Primary Cooking Options in the Ambitious E-cooking Scenario (Climate Change Management Division, 2021)

The table outlines expected changes in cooking methods among households in Nepal between 2020 and 2030. It reflects a shift toward cleaner and more efficient cooking options. The number of households using electric cookstoves is projected to rise sharply, from 3,73,605 in 2020 to 18,53,146 by 2030. Use of biogas cookstoves also increases steadily, from 6,84,942 households in 2020 to 11,86,013 in 2030. In contrast, households using LPG cookstoves remain almost unchanged, between about 3.17 and 3.28 million from 2020 to 2028, but then fall sharply to 335,662 by 2030. This change suggests a planned reduction or replacement of LPG with cleaner cooking options. Overall, the total number of households in Nepal is expected to increase from about 6.23 million in 2020 to more than 7.41 million in 2030. During this period the share of households using LPG cookstoves as the main cooking option drops sharply. These are gradually replaced by electric and ICS T3+ cookstoves. Under the ambitious e cooking scenario this trend shows Nepal steady move away from traditional and less efficient cooking methods toward cleaner and more sustainable options that support national clean cooking goals.

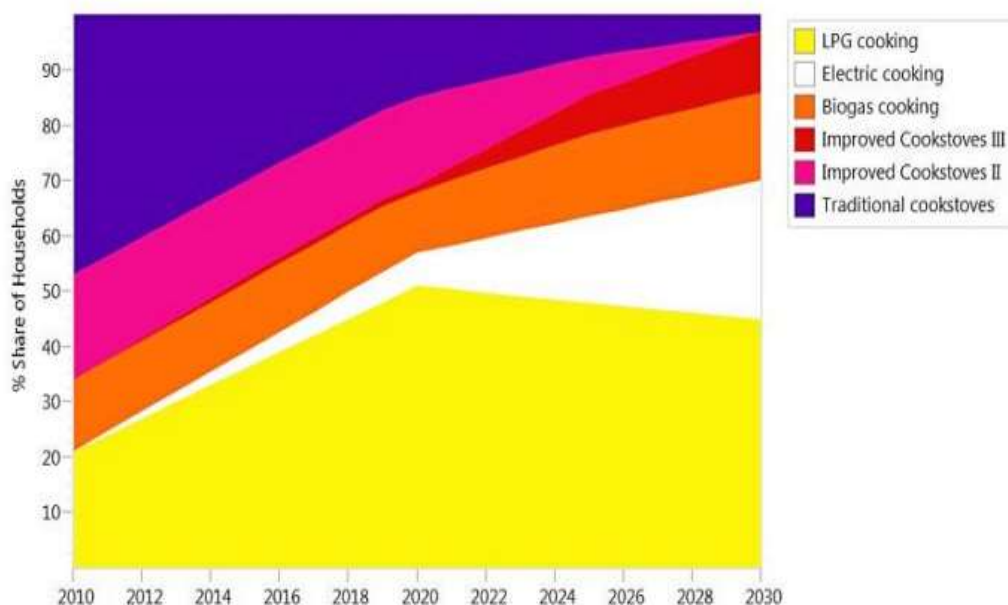

Figure 2.1. Percentage Share of Households using Different Primary Cooking Option in the Ambitious E-Cooking Scenario (Climate Change Management Division, 2021).

A clear pattern emerges in household cooking choices in Nepal between 2010 and 2030. During this time the use of traditional cookstoves shown in dark purple and older improved cookstoves shown in pink drops sharply. This points to a move away from inefficient and polluting practices. LPG cooking shown in yellow increases strongly from 2010, reaches its highest level around 2020, and then slowly declines as electric cooking shown in white and biogas cooking shown in orange become more common. Use of advanced improved cookstoves shown in red also grows steadily after 2020. By 2030 most households are expected to rely on cleaner and more modern cooking options, especially electric and advanced improved cookstoves, showing Nepal shift toward clean and sustainable household energy use.

2.2 Clean Cooking Standards in Nepal

Nepal has made significant strides in establishing and adopting clean cooking standards that align with both international best practices and national priorities for health, environment, and sustainable development. Clean cooking in Nepal is defined by the use of modern stoves and fuels that meet health-based emission targets and efficiency criteria, as outlined by the Clean Cooking Alliance and the International Organization for Standardization (ISO) guidelines. The most widely recognized benchmark is achieving at least Tier 3 or above for both efficiency and emissions, as per the ISO International Workshop Agreement (ISO-IWA) and the Nepal Interim Benchmark for Solid Biomass Cookstoves (Alternative Energy Promotion Centre (AEPC), Government of Nepal, 2016).

These standards regulate performance, safety requirements, and emissions that only the high performing high-quality appliances are propagated. The standards also are created with the collaboration of organizations such as the Alternative Energy Promotion Centre (AEPC), the Clean Cooking Alliance (CCA) as well as other stakeholders and are constantly revised to keep abreast with the changes in technology, and local demands (Nepal Bureau of Standards and Metrology (NBSM); Alternative Energy Promotion Centre (AEPC); Clean Cooking Alliance (CCA), 2025).

The attention by the government to these standards is based on the strong desire to increase air quality at the household level, decrease deforestation and greenhouse gas emissions due to reliance on traditional use of biomass and premature mortality due to air pollution and its morbidity effects in Nepal. The standards play a pivotal role in the national strategy of the country to reach universal access to clean cooking by 2030.

Technology	Efficiency Tier (ISO)	Meets Clean Standard (Tier 3+)	Typical Efficiency (%)	PM 2.5 Emissions (mg/MJ)	CO Emissions (g/MJ)	Notes
Traditional Mud Stove	0–1	No	<15	>1500	>20	High emissions, low efficiency
Improved Cookstove (ICS)	1–2	No	15–35	500–1500	5–20	Some improvement, not fully clean
Advanced ICS (Metallic)	3	Yes	35–45	<250	<2	Clean if tested/certified
Biogas Stove	3–4	Yes	40–60	<250	<2	Renewable, clean fuel
LPG Stove	2–3	Sometimes	50–73	<250	1–2	Clean if high efficiency model
Induction Stove	4	Yes	80–90	0	0	Highest efficiency, zero emissions
Electric Pressure Cooker	4	Yes	80–90	0	0	Clean, fast, safe

Table 2.2. Levels of Cookstoves Performance and Clean Cooking Technologies in Nepal (KC et al., 2024)

This table offers a comparative review of different cooking technologies being applied in Nepal with reference to their efficiency, emission and conformity with clean cooking

standards. The "Efficiency Tier (ISO)" column indicates the international performance tier for each technology, with Tier 3 and above recognized as meeting Nepal's clean cooking standard.

Advanced ICS (metallic), biogas stoves, induction stoves, and electric pressure cookers all meet or exceed Tier 3, delivering higher efficiency (above 35%) and much lower emissions. Notably, induction stoves and electric pressure cookers achieve the highest efficiency (80–90%) and produce zero on-site emissions, making them the cleanest options available.

In context of Nepal, tier 3 and above based on efficiency, emissions, safety, and durability are considered as clean cooking appliances. The commonly used clean cooking stoves in Nepal are induction stoves, LPG stove and biogas stoves. Although LPG stove is ranked above tier 3 by Renewable Energy Testing Station (RETS), it emits low CO (1.367 g/MJ), cleaner than biomass but less clean than induction(Adhikari et al., 2023).

Overall, the table highlights that only advanced ICS, biogas, induction, and electric pressure cooker technologies consistently meet Nepal's clean cooking standards, with induction and electric pressure cookers standing out for their superior efficiency and zero emissions.

2.3 Cooking Technology in Nepal

WECS has developed the hierarchy of different cookstoves and fuels used in Nepal based on their thermal efficiency as shown in Figure 2.2.

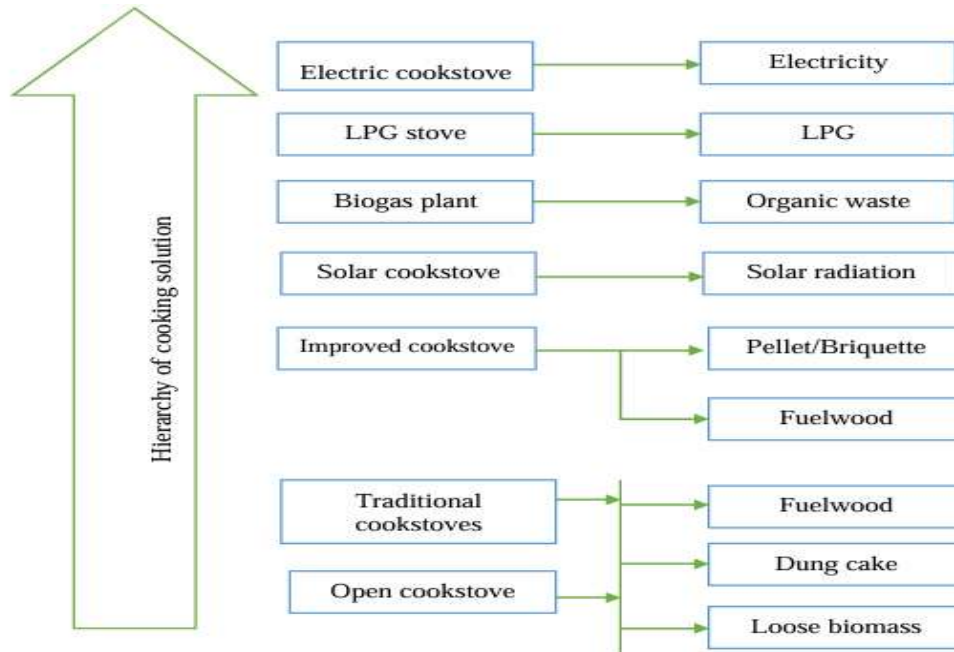

Figure 2.2. Hierarchy of Cooking Technologies (WECS, 2024)

Similarly, the overall hierarchy of cooking technology choices in Nepal is presented in figure 2.3. The induction stove was the best choice with 23.3% Massage priority and was therefore ranked first among nine cooking technologies(KC et al., 2024).

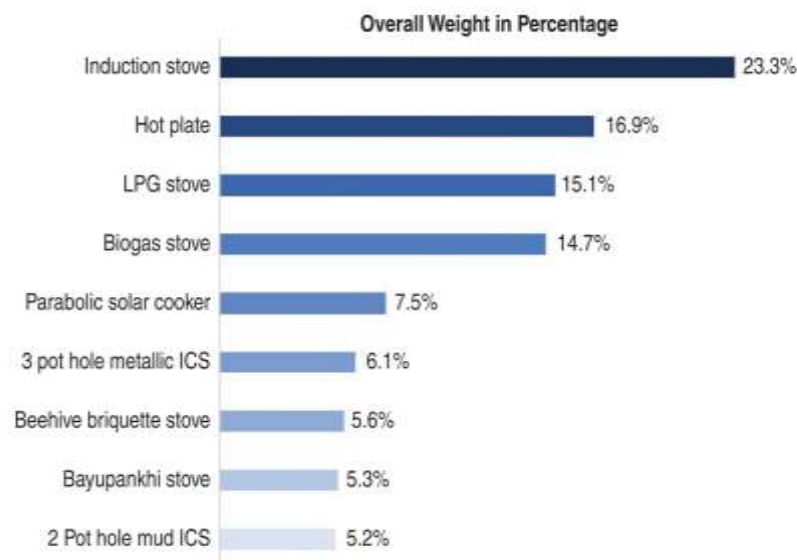

Figure 2.3. Overall Massage of Cooking Technologies

The chart displays the relative popularity or preference for different cooking technologies, measured as "overall Mass in percentage." According to the chart, induction stoves are the most favored, with a Mass of 23.3%, followed by hot plates at 16.9%. LPG stoves (15.1%) and biogas stoves (14.7%) are also significant, indicating that both electric and gas-based cooking solutions are widely valued. Among alternative and traditional technologies, parabolic solar cookers (7.5%), 3 pot hole metallic improved cookstoves (ICS) (6.1%), beehive briquette stoves (5.6%), Bayupankhi stoves (5.3%), and 2 pot hole mud ICS (5.2%) are less prominent.

The promotion of electric cooking gained momentum following blockade of the county's border in 2015-16. The resultant shortage of LPG acted as a catalyst for increasing the use of electric stoves in Nepal. A significant shift occurred with the introduction of the Electric Cooktop Standards in 2018 which established technical benchmarks for household induction hobs and hotplates. This document outlines specific standards, namely NS 561 and NS 562, addressing the electrical safety of induction cooktops and electric hotplates (Shrestha et al., 2024).

2.4 Health and Environment

Cooking with traditional fuels can lead to severe health issues caused by household air pollution (HAP) and also affects gender equality and drives environmental degradation. In 2022, a third of the global population, or 2.3 billion people, still did not have access to clean cooking. Reliance on polluting fuels, such as biomass, coal, and kerosene, has severe consequences for people and the planet. HAP contributes to up to 3.2 million deaths annually, with 60% being women and children. Women and girls disproportionately bear the burden of traditional cooking, spending up to 20 hours per week collecting fuelwood. Moreover, around 2% of global greenhouse gas emissions are produced by fuelwood burning. As of 2021, 14.9 million (51%) of 29.2 million people in Nepal relied on solid biomass to prepare meals. Burning of residential biomass was one of the main causes of HAP, which was responsible for over 21 000 premature deaths. Moreover, the residential sector produced about 6 million metric tons of CO₂ equivalent emissions (10%) of the country's total of 60 million net CO₂ equivalent metric tons. In recognizing the importance of clean cooking for unlocking climate and health benefits and reducing forest degradation, the Government of Nepal

has set ambitious clean cooking targets. Despite these benefits, only 28 countries including Nepal have policies related to clean cooking (Ramirez et al., 2024).

In many instances, firewood is burned on inefficient traditional cookstoves, leading to unacceptable levels of household air pollution (HAP). This results in over 22,500 premature deaths annually and a loss of more than 710,000 disability-adjusted life years (DALYs) each year (WHO, 2016). Electric cooking (e-cooking) is emerging as a preferred solution in Nepal to mitigate HAP, improve public health, and reduce reliance on LPG imports.

Despite Nepal's abundant hydropower potential and increasing electricity access, the adoption of electric cooking, particularly induction stoves, remains limited due to unreliable electricity supply, high initial costs, and lack of awareness. This reliance on traditional and LPG-based cooking hinders public safe cooking improvements, energy security, and alignment with national clean energy goals, such as the Second Nationally Determined Contribution (NDC) target of 25% household e-cooking adoption by 2030, as well as the international UN SDGs, especially SDG 7 (Affordable and Clean Energy) fulfilling the specific target of increasing access to electricity to 99% in 2030 (WECS, 2024).

2.5 International and Regional Experiences

Transition from LPG to a cleaner electric cooktop in Bhutan as a shift toward improved and more economical cooking technologies, where induction cooktops and infrared ovens have already gained popularity, but the low level of information about the economic advantage of different options creates difficulties in choice. In Bhutan, promotion of electric cooking is included in the government's goal of achieving low carbon development as Bhutan aims to reduce deforestation through the promotion of electric cooking (Kafle et al., 2019).

In South Africa, the government policy was alleviating the adoption of electric stoves and the price of the electric stoves became cheaper than the price of the gas stoves. The reason why electric cooking was encouraged was because of the imminent possibility of fire given by the paraffin stoves. To encourage the use of electricity as the main cooking fuel in the country, the Government of Ecuador initiated the National Efficient

Cooking Program (NECP) by switching 3 million existing gas stoves to induction stoves in the country(Kafle et al., 2019).

Similarly, South Africa's lifeline tariff policy provides all households with 50 kWh of free electricity per month. Likewise, many states in India provide significant electricity subsidies-Delhi offers free electricity to households consuming less than 200 kWh monthly(K.c. et al., 2025).

2.6 National Policy

The government policy and programs are significant in the switch to electric cooking. The Nepal Ministry of Energy, Water Resources and Irrigation, which has appreciated how hydropower can be used in two ways namely giving access to modern energy as well as clean cooking source, has published a white paper regarding the Electric Stove in Every House Program, which will likely stimulate electric cooking. It not only offers an opportunity to use the hydropower resources in Nepal, but also to decrease its reliance on imported fossil fuel. Based on the learning from other countries and with proper policy, programmes and access to technology, can help Nepal to transition from LPG to electric cooking in urban areas and solid fuels to electricity in rural areas(Kafle et al., 2019).

This study investigates Nepal's household clean cooking transition in light of recent policy shifts. The research indicates that even with increasing electricity access, socio-economic factors play a major role in fuel choice. For example, higher income and education correlate with LPG adoption, but awareness and cultural preferences affect willingness to try electric cooking. They also found that mere access to electricity or information (ICT access) does not automatically lead to fuel switching – highlighting a gap between potential and actual adoption. This suggests that policy interventions must address behavior change and not just infrastructure(Acharya et al., 2025).

The increasing usage of electricity has led to an increase in the per capita electricity consumption value and subsequently increased the residential electricity consumption per household. The overall electricity consumption of Nepal reached about 370 kWh per capita. However, the Ministry of Energy, Water Resources, and Irrigation (MoEWRI) has set an ambitious target to increase Nepal's per capita energy

consumption to 1,500 kWh by 2035(Government of Nepal, Water and Energy Commission Secretariat(WECS), 2024).

2.7 Technical and Economic Comparisons

An experiment conducted as a comparison of the cost, time, and energy consumption involved in cooking rice using LPG, coil heaters, rice cookers, induction cookers, and infrared cookers. The results revealed that induction cookers can reduce costs by up to 42% compared to LPG (Shrestha et al., 2020).

Electric cooking is another alternative which is becoming one of the potential clean cooking solutions in Nepal. The policy of electric cooking promotion is in the best interest of Nepal both at macro and microeconomic levels. An increase in the production of electric power and electrification rates is expected in the future, which means that facilitation of electric cooking has significant opportunities(Vaidya, 2020).

Efficiency and capital cost are key determinants in choosing cooking technologies in Nepal, with efficiency being the most influential factor, followed by capital cost. The study identified induction stoves as the top choice. Therefore, promoting electric cooking, especially induction stoves, is recommended to drive a transition to clean cooking(KC et al., 2024).

2.8 Institutional and Military Context

A key element in maintaining operational readiness and the physical fitness of soldiers is the regular provision of nutritious and safe meals. However, traditional cooking practices in Nepal, particularly in institutional settings, often depend on biomass fuels and inefficient stoves, which pose significant health risks, contribute to environmental degradation, and expose kitchen staff and soldiers to harmful indoor air pollution(Karmacharya, 2023).

Despite a design of 40 m³ biogas plant to replace partial LPG fuel in cooking, the plant operates only 22% of its capacity meeting only 3% of cooking demand, with contribution of maximum 13.7% cooking demand at its design capacity(Ghimire, 2025).

Adoption of electric rice cookers in Nepali Army showed the positive outcomes in terms of energy efficiency and cost benefits with the cost of steamer cooking only 35 percent of that of LPG cooking per kg of rice cooked(Batajoo, 2023).

CHAPTER THREE: METHODOLOGY

This study used a step-by-step process to evaluate the shift from LPG cooking to commercial electric induction cooking at the Sundarijal Arsenal barrack. The work begins with a technical assessment, where the performance, energy demand, electric load distribution and practicality of induction cooking are examined. After that, an financial and environmental analysis is carried out to compare costs, emissions, and long-term benefits against the current LPG system. The study then brings all these results together to give a clear sustainability picture towards transition from LPG to induction cooking. Based on the overall findings, practical policy recommendations will be developed to guide improvements and support future planning for cleaner and more efficient cooking solutions. The methodology used during the study is shown as follows:

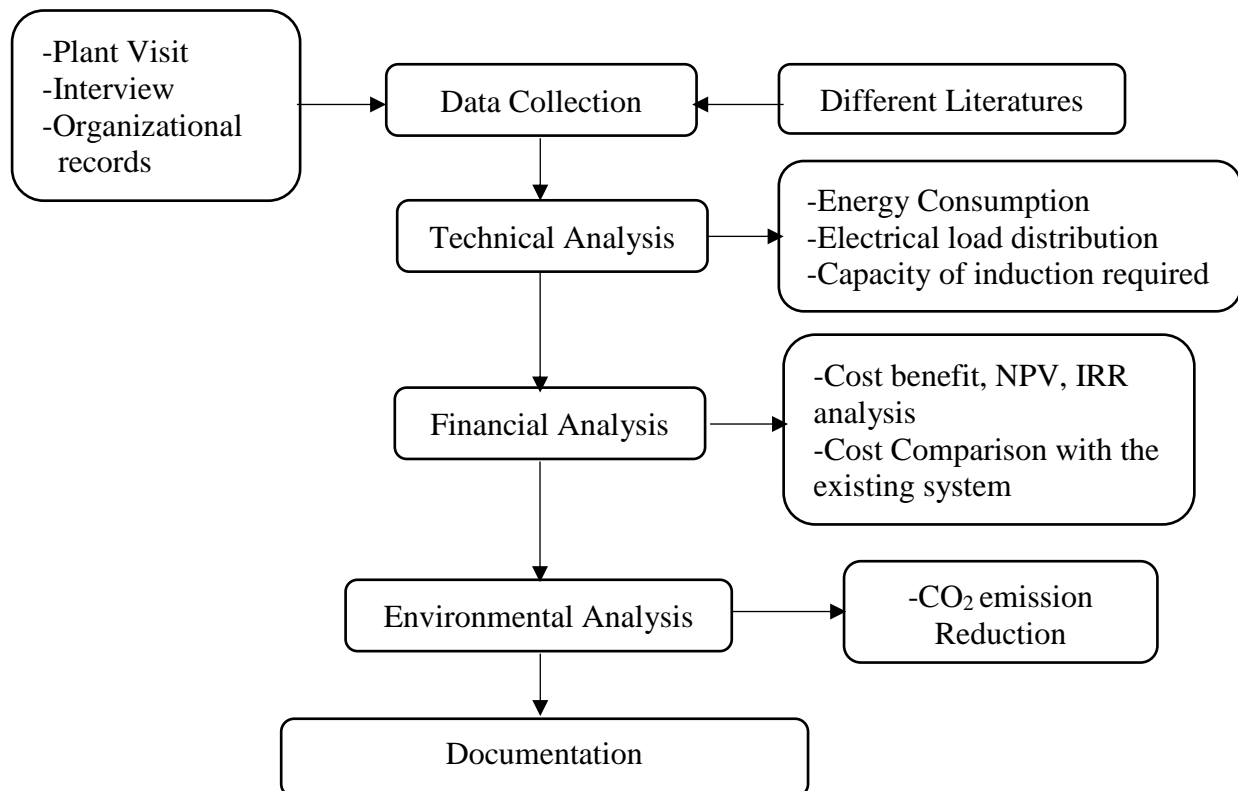

Figure 3.1: Research Methodology Flowchart

3.1 Study Area

This research has been carried out in Sundarijal Arsenal barrack to access the existing cooking practices, electricity infrastructure, and the practical challenges encountered during cooking with LPG. The study area was purposefully selected due to its relevance to institutional cooking operations and its potential for clean energy transitions.

3.2 Data Collection

Data collection is one of the most important aspect of any research which helps to determine the quality and output of any research. The study was performed by taking the useful and relevant data from the Sundarijal Arsenal barrack situated in Gokarneshwor Municipality, Kathmandu. Primary data were collected through direct observations and interview to the relevant personnel. The focus areas included the Annual LPG consumption, the availability of 3-phase electricity and the institutional plan for adopting induction based cooking. This study integrates a comprehensive review of literature and past research on clean cooking technologies in Nepal, drawing from both national and institutional perspectives. To contextualize the research and support analytical findings, secondary data were systematically collected from authorized sources.

3.3 Technical Analysis

The technical analysis was conducted to evaluate whether the existing LPG-based cooking system at Sundarijal Arsenal Barrack can be fully replaced by commercial electric induction cooking. The analysis focused on energy consumption, stove efficiency, required induction capacity, and the adequacy of the existing electrical infrastructure.

First, the annual LPG consumption was determined using organizational records. The total mass of LPG consumed per year was calculated using:

$$\text{Total LPG consumption (kg/year)} = \text{Number of cylinders} \times \text{LPG per cylinder} \dots(1)$$

The total energy input from LPG was then calculated using the calorific value of LPG:

$$\text{Total energy from LPG (kWh/year)} = \text{Total LPG consumption} \times \text{Calorific value of LPG} \dots(2)$$

To determine the actual useful energy available for cooking, the thermal efficiency of the existing LPG stoves was experimentally measured using the Water Boiling Test Version 4.2.3. During the test, the useful energy gained by water and the cooking pot was calculated as:

$$\text{Useful energy output (MJ)} = (m_w \times C_w + m_p \times C_p) \times \Delta T + mL \quad \dots(3)$$

where m_w is the mass of water, C_w is the specific heat capacity of water, m_p is the mass of the pot, C_p is the specific heat capacity of the pot material, ΔT is the temperature rise, m is the mass of water lost during boiling and L is the latent heat of vaporization of water.

The energy input during the test was calculated as:

$$\text{Energy input (MJ)} = \text{Mass of LPG consumed} \times \text{Calorific value of LPG} \quad \dots(4)$$

The thermal efficiency of the LPG stove was then calculated using:

$$\text{Thermal efficiency (\%)} = (\text{Useful energy output} / \text{Energy input}) \times 100 \quad \dots(5)$$

Using the experimentally obtained average thermal efficiency, the useful annual cooking energy from LPG was calculated as:

$$\text{Useful energy from LPG (kWh/year)} = \text{Total energy from LPG} \times \text{Thermal efficiency} \dots \dots \dots(6)$$

The daily useful energy demand was then obtained by dividing the annual useful energy by the number of days in a year. Since cooking is performed in two sessions per day, the useful energy per cooking session was calculated accordingly.

Next, the total cooking energy requirement was determined by adding the useful energy from LPG cooking and the existing electricity consumption used for appliances such as rice steamers. This provided the total energy demand per cooking session.

To replace the LPG system, the required induction cooking capacity was estimated using:

$$\text{Required induction capacity (kW)} = \frac{\text{Total energy consumption per session (kWh)}}{\text{Cooking duration (hours)}} \quad \dots(7)$$

Since induction cooktops do not operate at 100% efficiency, the actual installed capacity was calculated by accounting for induction efficiency:

$$\text{Actual induction capacity required (kW)} = \text{Required induction capacity} / \text{Induction efficiency} \quad \dots(8)$$

An average induction efficiency of 85% was assumed based on literature.

An electrical load analysis was then performed to assess system compatibility. The three-phase current drawn by the induction system was calculated using:

$$\text{Three-phase current (A)} = (P \times 1000) / (\sqrt{3} \times V \times \text{PF}) \quad \dots(9)$$

where P is the induction load in kW, V is the line voltage, and PF is the power factor.

The calculated current was compared with the rated capacity of existing cables and miniature circuit breakers (MCBs) to verify electrical safety and compliance with IEC standards. Necessary adjustments to protection devices were identified based on this comparison.

Finally, the annual electricity consumption of the proposed induction cooking system was calculated using:

$$\text{Annual electricity consumption (kWh/year)} = \text{Daily electricity consumption} \times 365 \quad \dots(10)$$

This enabled a direct comparison between the LPG-based and induction-based cooking systems in terms of total energy consumption and energy use per capita.

3.4 Financial Performance Parameters

The investment analysis is varied based on the economic parameters which characterize the shifting from LPG to induction cooking system. The economic parameters which are considered in order to evaluate are discussed in the section below.

3.4.1 Simple Payback Period

The total payback time to return the capital investment is known as simple payback period, and is an important decision-making indicator for the investment. Usually, shorter payback time is good for the investment. Simply, it is the length of time an

investment reaches in a breakeven point. Payback period is calculated using the formula below,

$$\text{Payback Period} = \frac{\text{Cost Of Investment}}{\text{Average Annual Cash Flow}} \quad \dots\dots\dots (11)$$

3.4.2 Net Present Value (NPV)

The most important economic criterion for assessing the system investment is the Net Present Value (NPV). It computes the present value of future cash using the discount rate to determine the investment profit. A profitable investment indicates a positive NPV, while the opposite is true for a negative NPV. The NPV is calculated using the formula below:

$$\text{NPV} = -C_0 + \sum_0^N \frac{C}{(1+d)^N} \quad \dots\dots\dots (12)$$

Where,

C = The total cash flow in given analysis time frame after tax,

C₀ = The capital investment,

d = Nominal discount rate and

N = Project Duration

3.4.3 Internal Rate of Return (IRR)

The discount rate at which an investment's net present value equals zero is known as the internal rate of return (IRR). One of the most used capital budgeting strategies is IRR. The hurdle rate is the minimal required rate of return. Setting the NPV to zero and solving for the discount rate, which is the IRR, will allow you to determine the IRR using the formula.

$$\text{NPV} = 0$$

$$\text{PV of future cash flow} - \text{Initial Investment} = 0$$

$$\left(\frac{\text{CF}_1}{(1+r)^1} + \frac{\text{CF}_2}{(1+r)^2} - \frac{\text{CF}_3}{(1+r)^3} + \dots \right) - \text{Initial Investment} = 0 \quad \dots\dots\dots (13)$$

Where,

r = internal rate of return;

CF1 = net cash inflow at period 1

CF2 = net cash inflow at period 2

CF3 = net cash inflow at period 3 and so on ...

3.5 Environmental Analysis

LPG is considered as a clean fuel. It burns clean as compared to firewood or any other petroleum products, but it's still a fossil fuel. When LPG burns, the biggest part of emission is carbon dioxide(CO₂) which is around 95-98% of total emissions while the other gases are H₂O, NO_x, CO as well as very tiny amounts of unburned hydrocarbons. Since, CO₂ emission is very large as compared to the other gases, it should be considered and calculated during the environmental analysis. The environmental analysis calculates the amount of emission reduced (mainly carbon dioxide).

$$\text{CO}_2 \text{ saved} = \text{LPG saved} \times 2.98 \text{ kg of CO}_2 \quad \dots\dots\dots (14) \quad (\text{Ghimire, 2025})$$

$$\text{Rate of Per tons of CO}_2 \text{ Equivalent} = 7 \text{ USD} \quad \dots\dots\dots (15) \quad (\text{Ghimire, 2025})$$

3.6 Comparison with the existing LPG cooking system

After the technical, financial and environmental analysis is done, the energy per capita, cost per capita as well the CO₂ saving comparison should be carried out to show how the scenario changes for both the existing LPG cooking system and after the adoption of commercial induction cooking system. The results are then analyzed and finally comes to the conclusion of transition, whether it will be feasible or not.

CHAPTER FOUR: RESULTS AND DISCUSSION

This chapter presents all the recorded data and findings, and it also evaluates them according to the framework shown in the methodology. All necessary calculations are performed using the formula specified in the methodology.

4.1 Technical Analysis

In this chapter, different calculations and technical analysis were carried out.

4.1.1 Annual LPG Consumption

The chart shown below shows the no. of LPG cylinder consumed per month. This gives the total annual consumption of 373 cylinder.

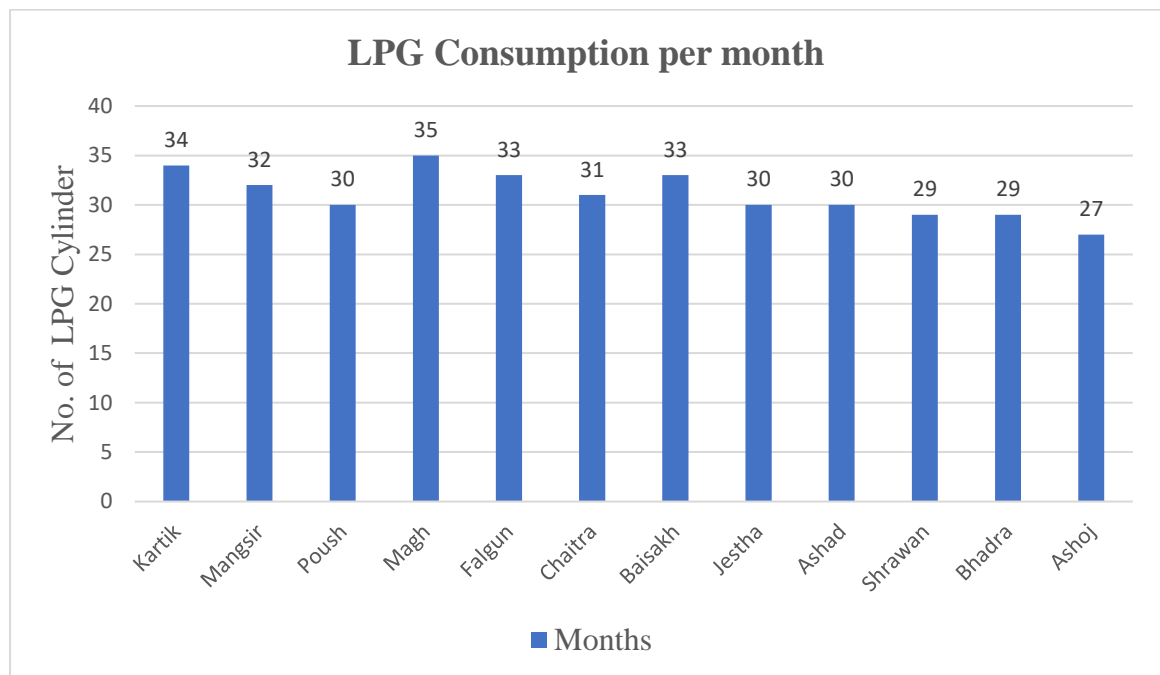

Figure 4.1: LPG Consumption Chart

4.1.2 Thermal Efficiency using Water Boiling Test

In Nepal, there are no formally codified standards for testing the thermal efficiency of cooking stoves. Therefore, the thermal efficiency of LPG cooking stoves is evaluated using the Water Boiling Test Version 4.2.3. The experimental setup was set according to the protocol. For each set of tests, a 10-liter pot was filled with 5 kg of water. The high power cold start and high power hot start phase was used to evaluate the thermal efficiency of LPG cooking stove.

The LPG cooking stove is connected to the LPG supply pipeline, which is linked with

the two LPG cylinders, and the pressure is controlled by a pressure regulator. There are two set of Commercial heavy-duty LPG system, one containing two LPG burner and the other containing only one LPG burner, making a total of three LPG burners used for cooking in the Sundarijal Arsenal barrack. Only one gas cylinder was used for testing the cooking stove while the other was turned off. The efficiency of all three LPG burners were measured one by one. At first, the initial Mass of LPG cylinder and the Mass of pot was measured. Then, the water was poured in the pot and the combined Mass of water as well as pot was measured. Then, the initial temperature of water was measured. The temperature was measured using TP 101 digital kitchen thermometer with long probe having accuracy of $\pm 1^{\circ}\text{C}$ and temperature measurement range of -50°C to $+300^{\circ}\text{C}$. Then, the pot was kept over the gas flame for boiling water. After, the water has reached the boiling point, the process was continued for extra 5 minutes. The final temperature of water, mass of the LPG cylinder as well as the mass of pot after boiling was noted.



Figure 4.2: LPG burner used for cooking in Sundarijal Arsenal barrack (Burner 1 on the left, Burner 2 on the middle and Burner 3 on the right)

The experiment was conducted for the cold start and hot start on burner 1, burner 2 and burner 3 respectively. The thermal efficiency of each burner is calculated as follows.

Taking, Specific heat capacity of water = 4.186 kJ/kg°C

Specific heat capacity of Aluminium = 0.89 kJ/kg°C

Calorific Value of LPG = 46 MJ/kg (equivalent to 12.78 kWh/kg) (EnergyPedia, 2020).

Mass of pot (Aluminium) = 1.05 kg

Mass of pot + Mass of water = 6.05 kg

Mass of water = 5 kg

Latent heat of water = 2260 kJ/kg

4.1.2.1 Burner 1

For Cold Start,

Initial Mass of LPG = 22.040 kg

Final Mass of LPG = 21.850 kg

Mass of water lost = 0.5 kg

Initial Temperature of water = 13.2 °C

Final Temperature of water = 97.3 °C

Energy Input = Net LPG used for boiling water x Calorific Value of LPG = 0.19 x 46
= 8.74 MJ

Energy Output = (Mass of water x Specific heat capacity of water + Mass of pot x
Specific heat capacity of pot) x Change in temperature + Mass of water lost x Latent
heat of Vaporization of water

= (5 x 4.186 + 1.05 x 0.89) x (97.3-13.2) + 0.5 x 2260

= 2.968 MJ

Thermal Efficiency = $\frac{\text{Energy Output}}{\text{Energy Input}} \times 100\% = \frac{2.968}{8.74} \times 100\% = 33.96\%$

For Hot Start,

Initial Mass of LPG = 21.850 kg

Final Mass of LPG = 21.680 kg

Mass of water lost = 0.5 kg

Initial Temperature of water = 13.4 °C

Final Temperature of water = 97.3 °C

Energy Input = Net LPG used for boiling water x Calorific Value of LPG = 0.17 x 46

$$= 7.82 \text{ MJ}$$

Energy Output = (Mass of water x Specific heat capacity of water + Mass of pot x Specific heat capacity of pot) x Change in temperature + Mass of water lost x Latent heat of Vaporization of water

$$= (5 \times 4.186 + 1.05 \times 0.89) \times (97.3-13.4) + 0.5 \times 2260$$

$$= 2.964 \text{ MJ}$$

$$\text{Thermal Efficiency} = \frac{\text{Energy Output}}{\text{Energy Input}} \times 100 \% = \frac{2.964}{7.82} \times 100 \% = 37.90 \%$$

4.1.2.2 Burner 2

For Cold Start,

$$\text{Initial Mass of LPG} = 21.680 \text{ kg}$$

$$\text{Final Mass of LPG} = 21.500 \text{ kg}$$

$$\text{Mass of water lost} = 0.55 \text{ kg}$$

$$\text{Initial Temperature of water} = 13.8 \text{ }^\circ\text{C}$$

$$\text{Final Temperature of water} = 95.5 \text{ }^\circ\text{C}$$

$$\begin{aligned} \text{Energy Input} &= \text{Net LPG used for boiling water} \times \text{Calorific Value of LPG} = 0.18 \times 46 \\ &= 8.28 \text{ MJ} \end{aligned}$$

Energy Output = (Mass of water x Specific heat capacity of water + Mass of pot x Specific heat capacity of pot) x Change in temperature + Mass of water lost x Latent heat of Vaporization of water

$$= (5 \times 4.186 + 1.05 \times 0.89) \times (95.5-13.8) + 0.55 \times 2260$$

$$= 3.029 \text{ MJ}$$

$$\text{Thermal Efficiency} = \frac{\text{Energy Output}}{\text{Energy Input}} \times 100 \% = \frac{3.029}{8.28} \times 100 \% = 36.58 \%$$

For Hot Start,

$$\text{Initial Mass of LPG} = 21.500 \text{ kg}$$

$$\text{Final Mass of LPG} = 21.340 \text{ kg}$$

$$\text{Mass of water lost} = 0.45 \text{ kg}$$

$$\text{Initial Temperature of water} = 13.8 \text{ }^\circ\text{C}$$

$$\text{Final Temperature of water} = 95.8 \text{ }^\circ\text{C}$$

$$\begin{aligned} \text{Energy Input} &= \text{Net LPG used for boiling water} \times \text{Calorific Value of LPG} = 0.16 \times 46 \\ &= 7.36 \text{ MJ} \end{aligned}$$

Energy Output = (Mass of water x Specific heat capacity of water + Mass of pot x

Specific heat capacity of pot) x Change in temperature + Mass of water lost x Latent heat of Vaporization of water

$$= (5 \times 4.186 + 1.05 \times 0.89) \times (95.8-13.8) + 0.45 \times 2260$$

$$= 2.809 \text{ MJ}$$

$$\text{Thermal Efficiency} = \frac{\text{Energy Output}}{\text{Energy Input}} \times 100 \% = \frac{2.809}{7.36} \times 100 \% = 38.16 \%$$

4.1.2.3 Burner 3

For Cold Start,

Initial Mass of LPG = 21.340 kg

Final Mass of LPG = 21.140 kg

Mass of water lost = 0.55 kg

Initial Temperature of water = 14 °C

Final Temperature of water = 97.1 °C

Energy Input = Net LPG used for boiling water x Calorific Value of LPG = 0.2 x 46 = 9.2 MJ

Energy Output = (Mass of water x Specific heat capacity of water + Mass of pot x Specific heat capacity of pot) x Change in temperature + Mass of water lost x Latent heat of Vaporization of water

$$= (5 \times 4.186 + 1.05 \times 0.89) \times (97.1-14) + 0.55 \times 2260$$

$$= 3.059 \text{ MJ}$$

$$\text{Thermal Efficiency} = \frac{\text{Energy Output}}{\text{Energy Input}} \times 100 \% = \frac{3.059}{9.2} \times 100 \% = 33.25 \%$$

For Hot Start,

Initial Mass of LPG = 21.140 kg

Final Mass of LPG = 20.950 kg

Mass of water lost = 0.6 kg

Initial Temperature of water = 13.9 °C

Final Temperature of water = 97°C

Energy Input = Net LPG used for boiling water x Calorific Value of LPG = 0.19 x 46 = 8.74 MJ

Energy Output = (Mass of water x Specific heat capacity of water + Mass of pot x Specific heat capacity of pot) x Change in temperature + Mass of water lost x Latent heat of Vaporization of water

$$= (5 \times 4.186 + 1.05 \times 0.89) \times (97-13.9) + 0.6 \times 2260$$

$$= 3.173 \text{ MJ}$$

$$\text{Thermal Efficiency} = \frac{\text{Energy Output}}{\text{Energy Input}} \times 100 \% = \frac{3.173}{8.74} \times 100 \% = 36.30 \%$$

The data sheet has been shown in Appendices B. The efficiency calculation of each burner is summarized in the Table 4.1. From the experiment, the average thermal efficiency of the LPG burner was measured to be 36 %.

Burner	Thermal Efficiency		Average
	Cold Start	Hot Start	
1	33.96	37.90	35.93
2	36.58	38.16	37.37
3	33.25	36.30	34.78
Average Thermal Efficiency			36.02% ≈ 36%

Table 4.1. Thermal efficiency of LPG cooking stove

Figure 4.3 shows the thermal efficiency comparison of each burner in different high power phases. In each burner, the hot start efficiency is higher than the cold start efficiency. Burner 2 shows maximum thermal efficiency for both cold start and hot start meanwhile burner 3 illustrate minimum thermal efficiency.

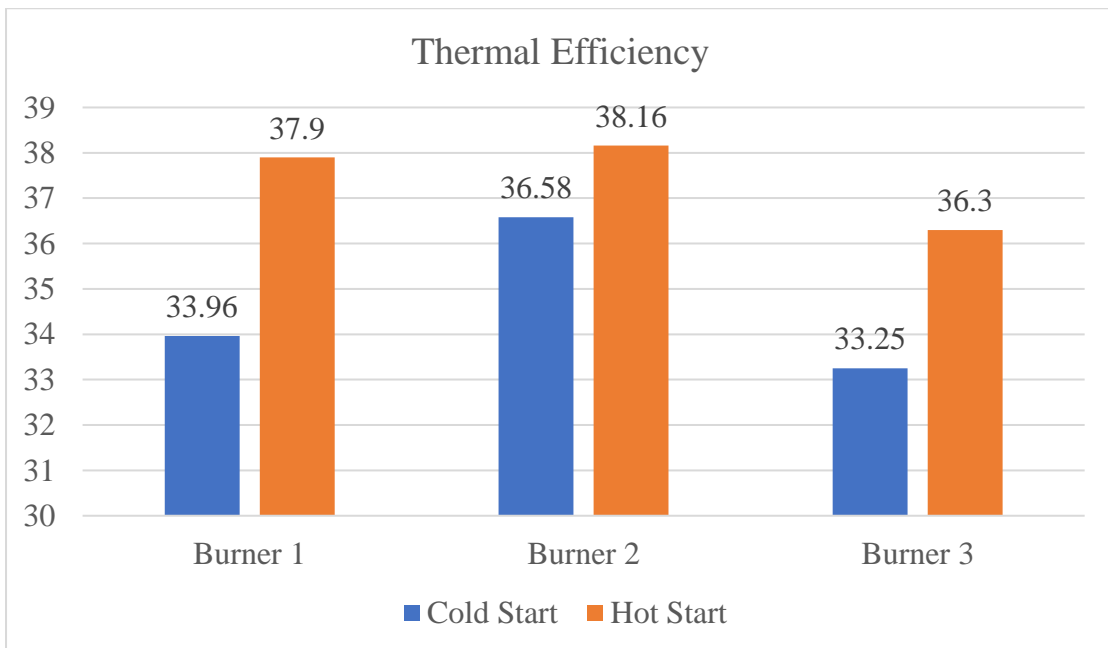

Figure 4.3: Thermal efficiency comparison of burners in different high power phase

4.1.3 Useful Energy Output from LPG

The Useful Energy from the LPG cooking system is calculated as:

Total mass of LPG (kg/year) = No. of cylinder used x kg per cylinder

$$= 373 \times 14.2 \text{ kg} = 5296.6 \text{ kg}$$

Thermal efficiency of LPG stove = 36% (from experiment)

Total energy from LPG cooking system (kWh/year) = Total mass of LPG x Calorific Value of LPG

$$= 5296.6 \times 12.78$$

$$= 67,690.55 \text{ kWh}$$

Useful energy from LPG (kWh/year) = Total energy from LPG x Thermal efficiency of LPG stove

$$= 67,690.55 \times 0.36$$

$$= 24,368.60 \text{ kWh}$$

Daily Useful energy from LPG (kWh/day) = 24368.60/365 (Taking 1 year = 365 days)

$$= 66.76 \text{ kWh} \approx 67 \text{ kWh}$$

Daily Useful energy from LPG (kWh/session) = 67/2 (Taking 2 sessions per day)

$$= 33.5 \text{ kWh}$$

4.1.4 Total Energy Consumption in the Barrack for Cooking

In Sundarijal Arsenal barrack, two different energy sources LPG and Electricity are used for cooking food. The electricity is used for operating Rice Steamer while the LPG is used for cooking other items such as lentils, vegetables, meat, paneer, pickle, etc. The daily per session energy consumption from different sources for cooking are shown

in the Table 4.2.

S.No.	Sources	Daily Consumption per session (kWh)	Remarks
1	LPG	33.5	
2	Electricity	9	Used for Rice Steamer (12 kW Rice Steamer operated for 45 mins per session)
	Total Energy Consumption per session per day (kWh)	42.5	

Table 4.2: Total Energy Consumption in the Barrack for Cooking

4.1.5 Total Capacity of Commercial Induction Cooktop required

The total energy consumption per session (morning & evening) per day is 42.5 kWh.

The required capacity of induction cooktop is calculated as:

Total Induction Capacity required = Daily energy consumption / Cooking hours per day

= 42.5/2 (Taking 2 hours of cooking time per session)

= 21.25 kW

Efficiency of Induction Cooktop = 85% (Avg.) (Darlami et al., 2020)

Required Capacity of Commercial Induction Cooktop = Total induction capacity required / Efficiency of induction cooktop

= 21.25/0.85

= 25 kW

4.1.6 Electrical Load distribution in the barrack

There are altogether three transformers used in the Sundarijal Arsenal barrack with the capacity of 1000, 500 and 500KVA. The two transformer of 1000KVA and 500KVA are fully used for factory section and the other 500KVA transformer is used partially for factory section and for the residential areas. The transformer used within the Sundarijal Arsenal barrack premises with the transformer rating is shown in the table

4.3.

S.No.	Transformer Rating (in KVA)	Distribution	Remarks
1	1000	Fully used for different Factory Section	
2	500		
3	500	Used partially for Factory Section and Residential Area	

Table 4.3: Transformer Rating

The total transformer capacity of all the three transformer is 2000KVA and the approved load for these transformers from the Nepal Electricity Authority is also 2000KVA. Appendices D shows the Electricity bill of Sundarijal Arsenal for Kartik/2082 where it can clearly be seen that the approved load is 2000 KVA. The total electrical load distribution chart for the Sundarijal Arsenal barrack is shown in the figure 4.4. The figure shows how the connection had been done within the barrack premises (both factory as well as the residential areas) along with the wire sizing and the safety devices used like circuit breaker. The kitchen area (Red box area) is where the rice steamer has been placed with 10 sq.mm cable connected with 80 A MCB. The cable used is 3-phase, 4-core XLPE cable. According to IEC 60364-5-52 Methods of Installation and current-carrying capacities, for a 4-core, 10 mm² copper conductor with XLPE/EPR insulation mounted directly to a wall, the maximum current-carrying capacity is 71 A. The existing circuit breaker MCB will not be suitable for this wire as the rated current of MCB is greater than the maximum current carrying capacity of the wire. The circuit breaker and wire sizing analysis needed because of the reason that the Nepali Army plan of procurement of electric induction cooking stoves will be suitable in the electrical infrastructure or should it be replaced with new one.

In the initial phase, the Nepali Army focused on introducing electric induction cooking for 200 units by using the available three-phase electricity system and existing infrastructure. For this purpose, around NRs. 1 million has been allocated for each unit to procure eight types of cooking utensils, including induction stoves, for implementing induction-based cooking (*Procurement of Electric Stove with Various Utensil, 2025*).

The list of the eight items is provided in the table 4.4.

S.No.	Item	Unit	Quantity	Remarks
1	Tilting Bratt Pan (9 kW/110L)	Set	1	
2	Flat Top Induction (9 kW)	Set	1	
3	Wok Top Induction (9 kW)	Set	1	
4	Induction Based Stock Pot (113L)	Set	1	
5	Induction Based Stock Pot (58L)	Set	1	
6	Induction Based Stock Pot (32L)	Set	1	
7	Induction Based Pressure Cooker (80L)	Set	1	
8	Induction Based Karai (17L)	Set	1	

Table 4.4. List of Cooking Utensils including Induction Stove

Table 4.4 clearly shows that the induction cooking system is of 27 kW capacity. The formula of 3 phase current will be written as $\text{Amps} = (\text{kW} \times 1000) / (\sqrt{3} \times \text{Volts} \times \text{PF})$. Taking 380V and PF as 0.8, the 3 phase current will be 51.3 A. According to IEC 6089-1 Electrical accessories – Circuit-breakers for overcurrent protection for household and similar installations, preferred values of rated current are 6 A, 8 A, 10 A, 13 A, 16 A, 20 A, 25 A, 32 A, 40 A, 50 A, 63 A, 80 A, 100 A and 125 A. For the existing cooking system, a MCB of 63 A will be suitable with the current wire size of 10 mm². Hence, the existing MCB has to be changed from 80 A to 63 A.

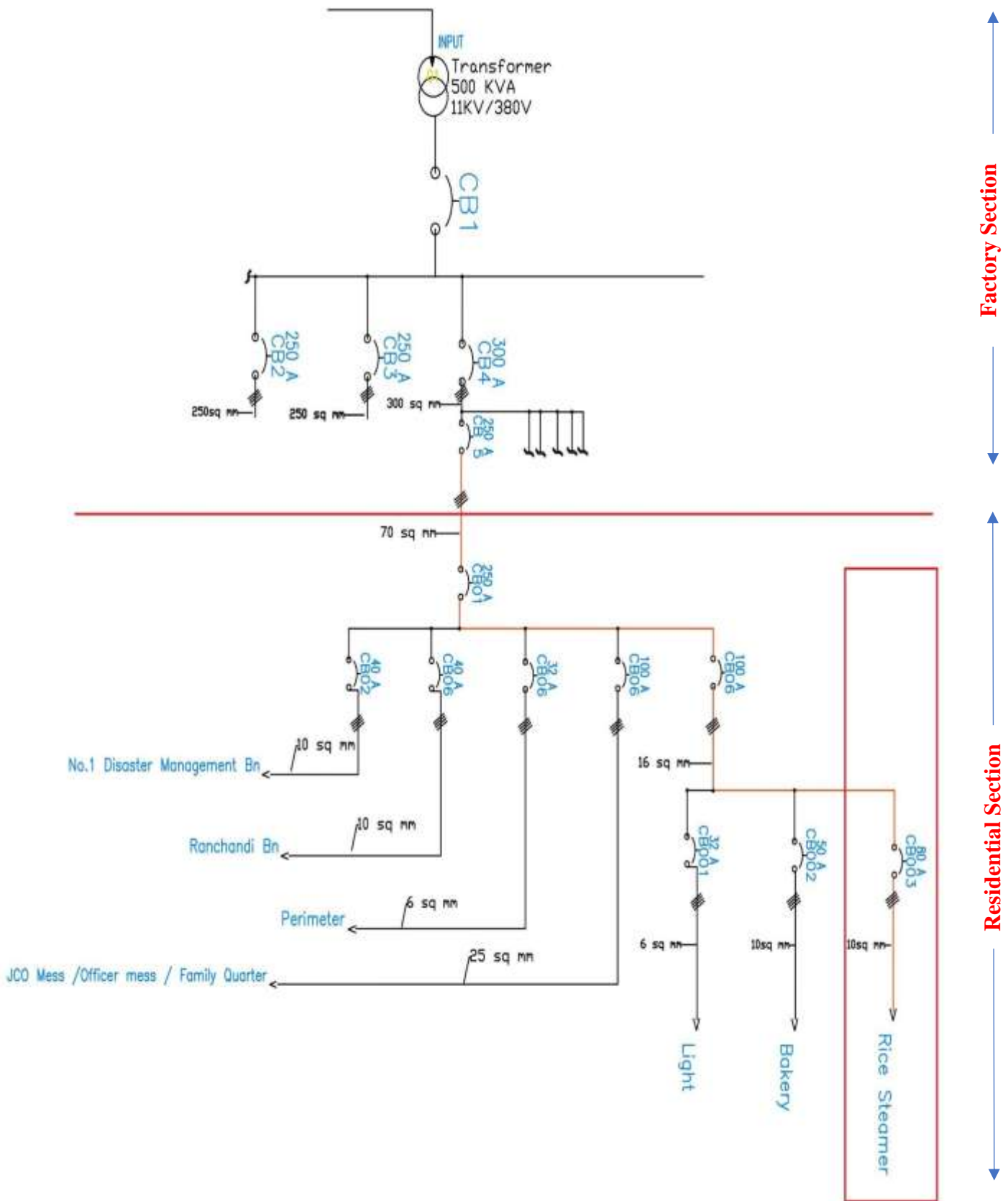

Figure 4.4: Electrical load distribution chart of Sundarijal Arsenal barrack

4.1.7 Barrack Population

The number of army personnel of the Sundarijal Arsenal barrack over the timeframe of 10 years is shown in the figure 4.5.

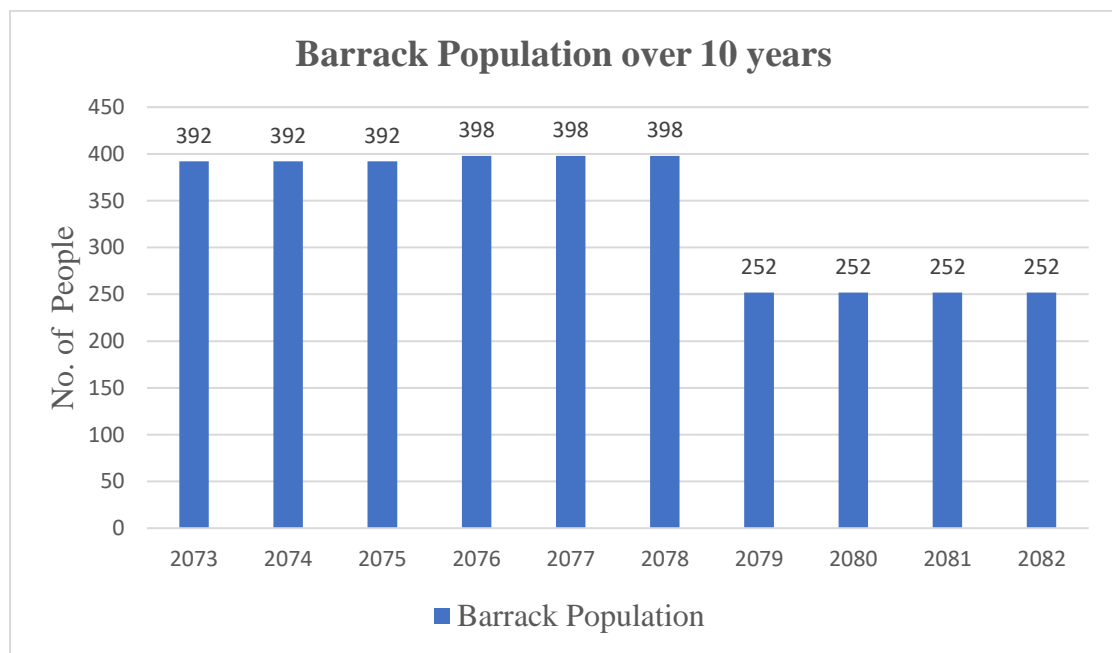

Figure 4.5: Barrack Population over 10 years

From 2073 to 2078, the barrack population stayed around 392 to 398 soldiers, showing a stable strength. However, from 2079 onward, the number dropped sharply and settled at 252 personnel. At present, in 2082, the Sundarijal Arsenal barrack accommodates 252 army personnel, and this number has remained constant for the last few years. The barrack population is shrinking at roughly 4.32% per year from 2073 BS to 2082 BS.

As illustrated in figure 4.5, the barrack population is experiencing a steady decline and there is no any sign of growth of population in the upcoming years. Consequently, installing the new induction cooking system scaled to the specific capacity is an appropriate solution for the current residents of the Sundarijal Arsenal barrack and no future expansion is anticipated.

4.2 Financial Analysis

Financial analysis of the commercial induction cooktop is done by evaluating the payback period, internal rate of returns (IRR) and net present value (NPV) to see whether the decision of Nepali Army to replace the existing LPG cooking system will be financially feasible or not.

From the bidding document issued on 2082/03/31 BS by the Directorate of Supply and Transport, Nepali Army for the procurement entitled “Electric stove with various utensil” for 200 units, the bid security fee is NPR 56,00,000 with a bidding fee of NPR 10,000 (Non-Refundable) as shown in the Appendices E.

The Public Procurement Regulation, 2064 (2007), Chapter 5, Rule 48 (1)(c), for the bidding fee of ten thousand, the estimated price of project to be one hundred million rupees but not exceeding two hundred fifty million rupees. Also, The Public Procurement Regulation, 2064 (2007), Chapter 5, Rule 53 (1), the bid security is certain amount which is within a minimum of two to three percent of the amount of approved cost estimate. Taking, 2.5% of estimated price will be bid security amount to NPR 56,00,000. From this, the total estimated price of project is calculated to as NPR 22,40,00,000. For a single unit, the price of the procurement will be NPR 11,20,000.

The table 4.6 shows the detailed financial analysis by fully replacing the existing LPG cooking system by electric induction cooking system.

Total Cost of Electric Induction Cooktop with utensils	NPR 11,20,000	
Annual Maintenance cost	NPR 33,600	Taking 3% of total cost
Daily Electricity Consumption	85 kWh	42.5 kWh per session @ 2 sessions per day
Total Annual Electricity Consumption	31,025 kWh	Taking 365 days per year
Total Annual Electricity Cost	NPR 3,80,056.25	NPR 12.25 during normal time
Total cost saving from LPG	NPR 7,12,430	373 cylinders @ NPR 1910 per cylinder (<i>LPG Prices, 2025</i>)
Total net cost savings	NPR 2,98,773.75	Total cost saving from LPG-Total Annual Electricity Cost-Annual Maintenance cost
Time period (Shelf life)	10 years	(10-15) years (AT Cooker, 2025)
Simple payback period	3.75 years	
IRR	23.425%	
NPV	NPR 7,15,835.36	@10%

Table 4.5: Financial Analysis

From the financial analysis, it can be concluded that the total annual cost associated with the LPG cooking system is NPR 7,12,430 and the total annual cost associated with the induction cooking system is NPR 3,80,056.25 which is nearly half of the cost of LPG cooking system. The transition has also supported by the higher IRR of 23.425% with the Net Present value of NPR 7,15,835.36 for the timeframe of 10 years.

4.3 Environmental Analysis

Burning of Fossil fuel like LPG for cooking emits different greenhouse gases like CO₂. The transition to Commercial electric induction cooking in replacement of LPG will save the CO₂ emission and helps in the burning issues like climate change, global warming as well as health issues occurring due to indoor air pollution. The calculation are based on the assumption that the only emission from the LPG cooking is fully CO₂. The total CO₂ equivalent from LPG as well as the total cost savings from CO₂ reduction in shown in the Table 4.7.

Calculation of CO ₂ Equivalent from LPG savings		
Total Mass of LPG Saving / annum	5296.6	Kg
Conversion Factor	2.98	Kg of CO ₂ Equivalent
Total CO ₂ Equivalent / annum	15.8	Tons of CO ₂ Equivalent
Rate of Per tonnes of CO ₂ Equivalent	7	USD
Total Cost Saving	110.6	USD per Annum
Total Cost Saving (NPR)	15,989.4	1USD = NPR 144.57

Table 4.6: Calculation of CO₂ Equivalent from LPG savings as well the total cost savings

The study evaluates the total CO₂ Equivalent emissions per annum will be 15.8 tonnes, with a total cost saving of NPR 15,989.4 from the CO₂ reduction.

4.4 Comparison with the existing LPG cooking system

In this analysis, the energy per capita, cost per capita as well as the total CO₂ emission reduction and the cost savings from the CO₂ emission reduction is compared to ensure that which cooking system will give the highest benefits. The comparison is done in three section, first is technical section where the energy consumption per capita from both the cooking system is compared, second one is financial section where the cost per capita for both cooking system is compared and finally the third is environmental section where the total CO₂ emission reduction and the cost savings from the CO₂ emission reduction is compared. The each comparison is carried out by considering the number of army personnel to be 252.

4.4.1 Technical Comparison

In this section, the energy per capita from LPG cooking system and the energy per capita from commercial induction cooking system is compared. From above technical analysis,

Total energy from LPG cooking system (kWh/year) = Total mass of LPG x Calorific Value of LPG

$$=5296.6 \times 12.78$$

$$= 67,690.55 \text{ kWh}$$

$$\text{Energy per capita from LPG} = 67690.55 / 252 = 268.6 \text{ kWh/year}$$

$$\text{Total energy from induction cooking system (kWh/year)} = \text{Total Energy Consumption per session per day (kWh)} \times 2 \times 365$$

$$=42.5 \times 2 \times 365$$

$$= 31,025 \text{ kWh}$$

$$\text{Energy per capita from induction} = 31025 / 252 = 123.11 \text{ kWh/year}$$

The energy used per person for LPG cooking system is 268.6 kWh/year whereas the energy used per person for Induction cooking system is 123.11 kWh/year which is less than half of the energy used. The figure 4.6 shows the comparison chart for energy per capita for both LPG and induction cooking system.

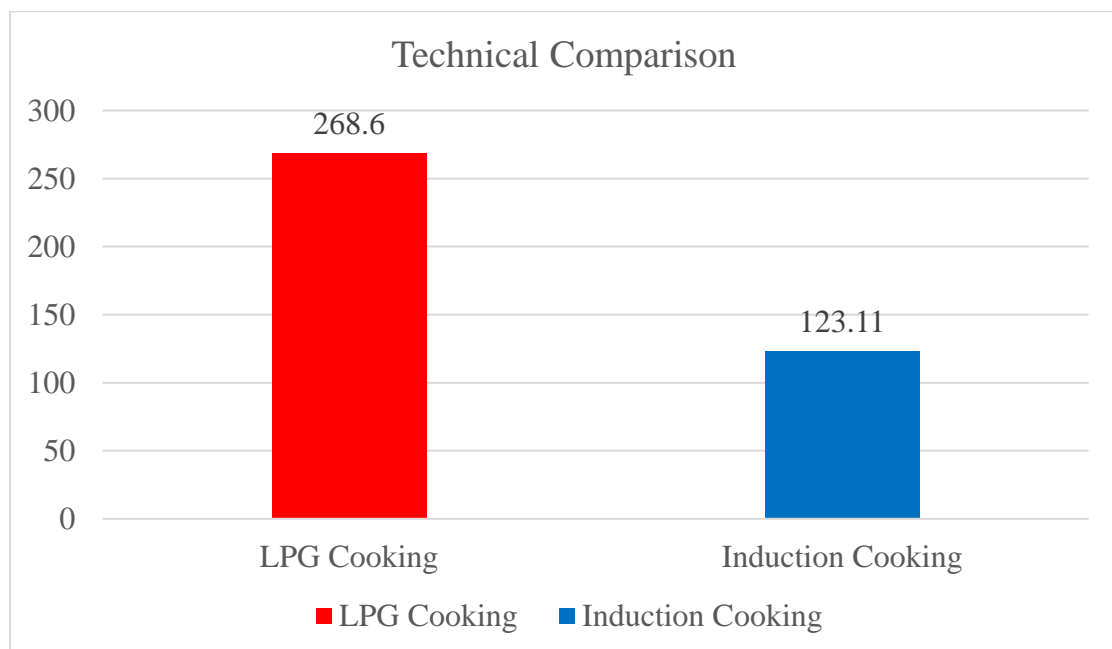

Figure 4.6: Energy per capita per year (kWh/year) for both LPG and Induction cooking system

4.4.2 Financial Comparison

In this section, the cost per capita from LPG cooking system and the cost per capita from commercial induction cooking system is compared. From above technical analysis,

Total cost from LPG cooking system = No. of LPG cylinder used x Cost per cylinder

$$= 373 \times 1910$$

$$= \text{NPR } 7,12,430$$

Cost per capita per year from LPG = $712430 / 252 = \text{NPR } 2827.1 / \text{year}$

Total cost from Induction cooking system = NPR 3,80,056.25

Cost per capita per year from induction = $380056.25 / 252 = \text{NPR } 1508.16 / \text{year}$

The cost per person for LPG cooking system is NPR 2827.1 /year whereas the cost per person for Induction cooking system is NPR 1508.16 /year which is nearly half of the cost used. The figure 4.7 shows the comparison chart for cost per capita for both LPG and induction cooking system.

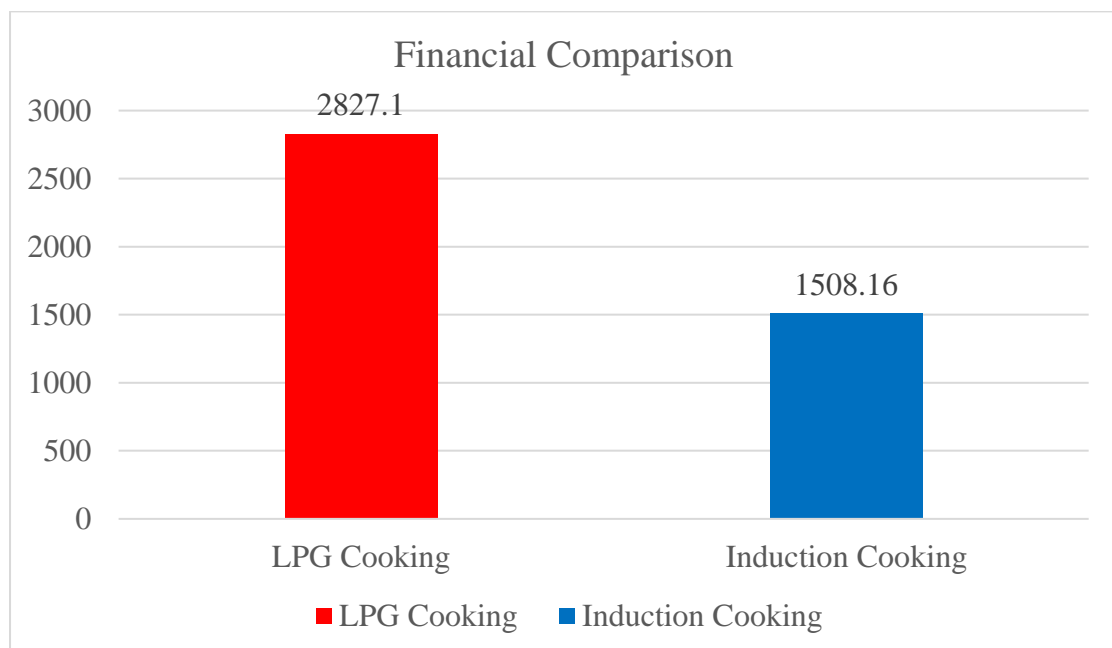

Figure 4.7: Cost per capita for both LPG and Induction cooking system

4.4.3 Environmental Comparison

In this section, the CO₂ emission reduction and the cost savings from the CO₂ emission reduction per capita from LPG cooking system and commercial induction cooking system is compared. From above environmental analysis,

Total CO₂ Equivalent / year = 15.8 tons of CO₂

CO₂ emission reduction per capita per year from Induction = $15.8/252 = 62.7$ kg of CO₂ / year

Total cost savings from CO₂ emission reduction = NPR 15,989.4 / year

Cost savings per capita per year from CO₂ emission reduction = $15989.4 / 252 =$ NPR 63.45 /year

The CO₂ emission reduction per person from Induction cooking system is 62.7 kg of CO₂ / year whereas the cost savings per person from CO₂ emission reduction for Induction cooking system is NPR 63.45 /year. The figure 4.8 shows the comparison chart for CO₂ emission reduction per capita for both LPG and induction cooking system and figure 4.9 shows the cost savings from CO₂ emission reduction per capita per year for both LPG and induction cooking system.

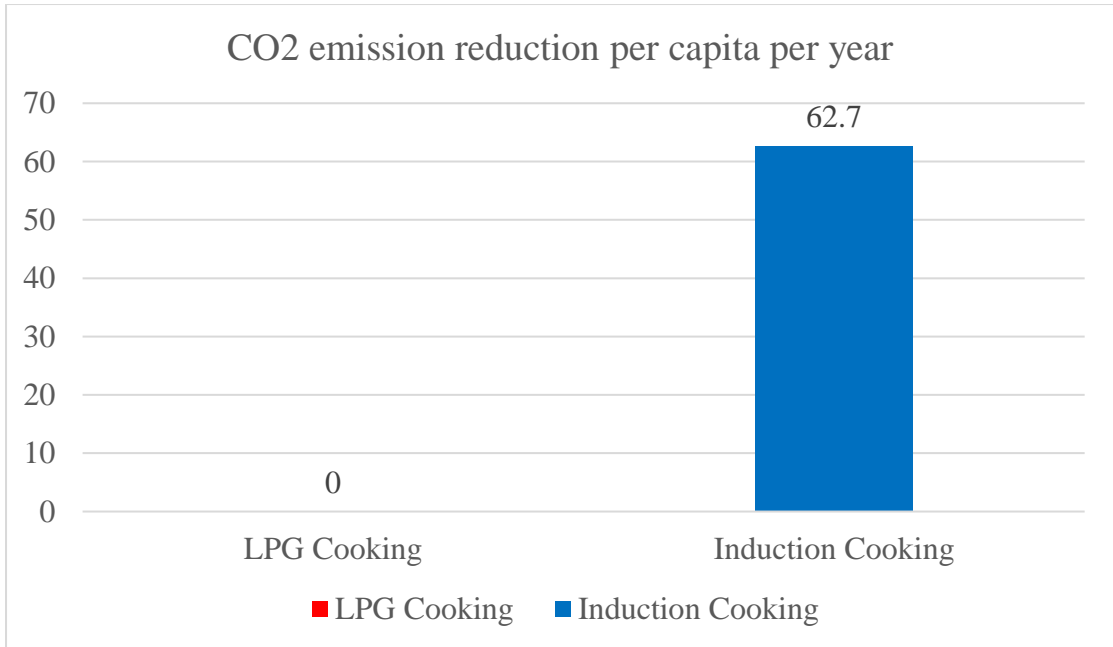

Figure 4.8: CO2 emission reduction per capita per year (kg/year) for both LPG and Induction cooking system

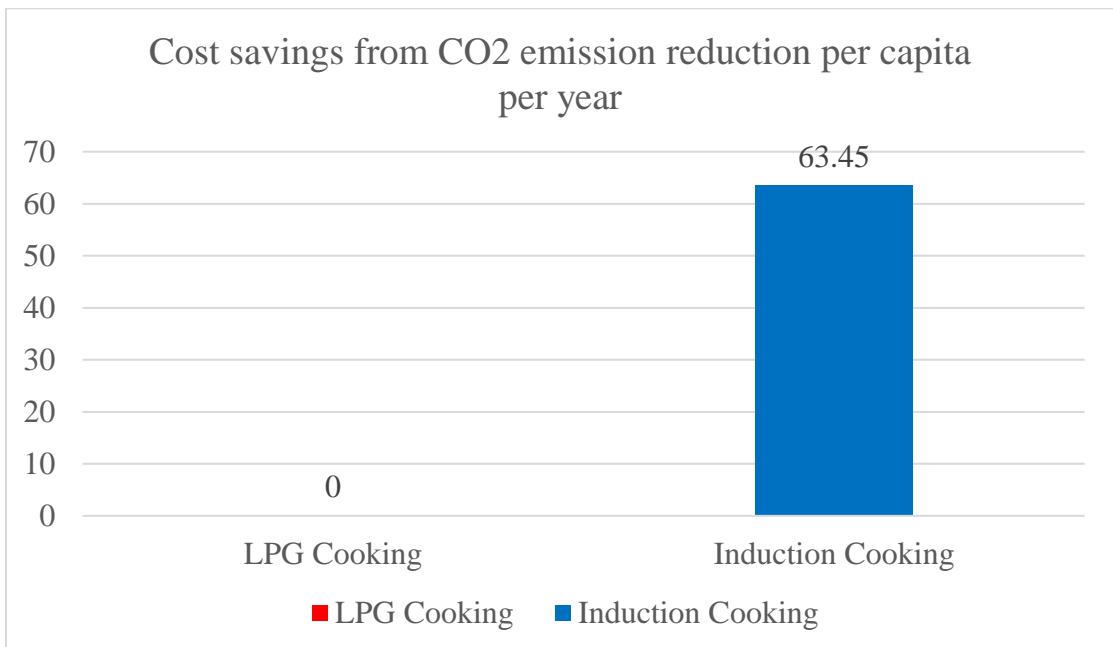

Figure 4.9: Cost savings from CO₂ emission reduction per capita per year (NPR/year) for both LPG and Induction cooking system

CHAPTER FIVE: CONCLUSIONS AND RECOMMENDATIONS

5.1 Conclusions

Following conclusions has been drawn based on the study

- This study was conducted at the Sundarijal Arsenal Barrack to evaluate the feasibility of transitioning the existing LPG-based cooking system to electric induction cooking. The barrack currently serves around 252 personnel daily, and cooking activities consume a significant amount of LPG every year. Due to rising LPG prices, heavy dependence on imported fuel, and low stove efficiency, the existing system has become costly and inefficient, creating a strong need for a better cooking alternative.
- The objective of the study was to assess whether induction cooking could function as a primary cooking solution for Sundarijal Arsenal barrack by examining its technical feasibility, energy efficiency, financial performance, and environmental benefits under current operating conditions at the barrack.
- The study used a practical, site-based methodology that included field visits, direct observation of daily cooking practices, and interviews with kitchen staff and technical personnel. Actual LPG consumption data were collected and converted into energy terms to determine useful energy output. The required induction capacity was calculated based on cooking demand, and the existing three-phase electrical infrastructure was evaluated to confirm system compatibility. Financial and environmental analyses were then carried out using standard evaluation methods.
- The analysis showed that the barrack consumes 5,296.6 kg of LPG per year, corresponding to an annual energy input of 67,690.55 kWh. However, due to the low thermal efficiency of LPG stoves, only about 36% of this energy is effectively used for cooking. As a result, the energy consumption per person is high, at 268.6 kWh per year.
- To replace the LPG system, an induction cooking capacity of approximately 25 kW was found to be sufficient, and this demand can be fully supported by the existing three-phase electricity supply at the barrack. The proposed induction system consumes around 85 kWh per day, or 31,025 kWh per year, assuming two cooking sessions per day.

- With induction cooking, the energy consumption per person is reduced to 123.11 kWh per year, which is less than half of the energy required by the LPG-based system. This clearly demonstrates the higher efficiency of induction cooking compared to conventional LPG stoves.
- The financial analysis strongly supports the transition to induction cooking. The barrack currently spends approximately NPR 7,12,430 per year on LPG, whereas the annual electricity cost for induction cooking is about NPR 3,80,056.25. The total investment cost for the induction system is around NPR 11,20,000, resulting in a simple payback period of 3.75 years, an internal rate of return of 23.425%, and a net present value of NPR 7,15,835.36 over a ten-year period.
- From an environmental perspective, the transition to induction cooking reduces CO₂ emissions by about 15.8 tonnes per year, which is equivalent to 62.7 kg of CO₂ per person annually. Although the direct monetary savings from carbon reduction are relatively small at NPR 63.45 per person per year, the environmental and energy security benefits are significant.
- The per-capita analysis further highlights the advantages of induction cooking. The annual cooking cost per person using LPG is NPR 2,827.1, while the cost per person using induction cooking is reduced to NPR 1,508.16 per year. This shows clear economic benefits alongside energy savings.

Overall, the study confirms that transitioning from LPG to induction cooking at Sundarijal Arsenal Barrack is technically feasible, economically viable, energy efficient, and environmentally sustainable. By utilizing locally generated hydropower instead of imported LPG, the Nepali Army can reduce long-term costs, improve energy security, and adopt a cleaner and more resilient cooking system and is also suitable for large commercial kitchens like security personnel barracks, hostel, banquet, hotel, etc.

5.2 Recommendations

Based on the findings of this study on transitioning from LPG cooking to commercial electric induction cooking at the Sundarijal Arsenal Barrack, the following recommendations are proposed:

- The Nepali Army should gradually expand the use of commercial electric induction cooking across other barracks where reliable three-phase electricity is already available. The results clearly show that induction cooking is technically feasible within existing electrical infrastructure and provides significant energy and cost savings compared to LPG.
- Induction cooking systems should be designed based on actual cooking demand, cooking schedules, and number of personnel in each barrack. Site-specific load assessments should be carried out before installation to ensure proper sizing of induction cooktops and to avoid overloading or underutilization of equipment.
- Kitchen staff should be provided with basic training on the operation and power control of commercial induction cooktops. Proper training will help prevent issues such as food burning, uneven cooking, and inefficient use of electricity, and will also increase acceptance of the new technology.
- Future studies should use long-term operational data for electricity consumption and maintenance costs instead of assumed values. Collecting real field data over multiple years will improve the accuracy of economic analysis and strengthen investment decision-making.
- Backup power arrangements, such as grid redundancy or limited LPG or electric alternatives, should be considered to ensure uninterrupted cooking during power outages, especially in critical institutional settings like army barracks.
- Environmental benefits beyond carbon dioxide reduction, such as improved indoor air quality and health benefits for kitchen staff, should be quantified in future research. Including these non-monetary benefits will provide a more comprehensive sustainability assessment.
- Finally, government agencies and energy policymakers should consider institutional kitchens as priority targets for electric cooking promotion. The successful adoption of induction cooking in the Nepali Army can serve as a model for other public institutions, contributing to national clean energy goals, reduced LPG imports, and improved energy security in Nepal.

REFERENCES

- Acharya, B., Pant, D. P., & Kattel, M. R. (2025). Household clean cooking in Nepal: Policies, practice and prospects. *Energy Policy*, 206, 114758. <https://doi.org/10.1016/j.enpol.2025.114758>
- Adhikari, N. P., Shakya, P. R., Shrestha, S. L., & Prajapati, S. (2023). A Comparative Study of Energy, Emissions, and Economic Efficiency of Various Cookstoves in Nepal. In K. P. Vadrevu, T. Ohara, & C. Justice (Eds.), *Vegetation Fires and Pollution in Asia* (pp. 317–337). Springer International Publishing. https://doi.org/10.1007/978-3-031-29916-2_19
- AT Cooker. (2025). Commercial Induction Stove Durability: 10-15 Year Lifespan | AT Cooker. A Professional Cooking Equipment Manufacturer & Exporter. <https://www.atcooker.com/commercial-induction-stove-durability-lifespan/>
- Batajoo, M. (2023). Performance and Financial Analysis of Replacing LPG Stoves by Electric Rice Steamers for Rice Cooking: A case study of Nepali Army (Swayambhu Baroodkhana Karyalaya). <https://elibrary.tucl.edu.np/items/9dad6925-08ed-44cd-a065-f28cefb7a9d8>
- Climate Change Management Division. (2021). Assessment of Electric Cooking Targets for Nepal's 2020 Nationally Determined Contributions (NDC). ,MoFE, GoN.
- Darlami, H. B., Chaudhary, R., & Budha, B. K. (2020). Cooking Devices and their Thermal Efficiencies in the Context of Nepal: A Review. 07(11).
- Energypedia. (2020). Liquefied Petroleum Gas (LPG). [https://energypedia.info/wiki/Liquefied_Petroleum_Gas_\(LPG\)](https://energypedia.info/wiki/Liquefied_Petroleum_Gas_(LPG))
- Ghimire, M. K. (2025). Sustainability Assessment of Institutional Biogas Plant in Nepal- A Case Study of Sundarijal Arsenal Biogas Plant. <https://elibrary.tucl.edu.np/items/4fd350c0-b027-4ff3-b16f-65e250b0ff12>
- GoN. (2020). Second Nationally Determined Contribution (NDC). Government of Nepal (GoN).
- Government of Nepal, Water and Energy Commission Secretariat(WECS). (2024). Energy Sector Synopsis Report.
- Kafle, S., Mishra, A. K., Maharjan, A., & Panday, A. K. (2019). Moving from Fossil Fuels to Electric Cooking: An Option for Clean Cooking Access in Nepal. *Journal of the Institute of Engineering*, 15(3), 159.
- Karmacharya, S. (2023). Practices of institutional meal in Armed Police Force, Nepal. <https://elibrary.tucl.edu.np/items/0b8e77aa-8e52-40e3-8679-71c1530f3dc8>
- KC, D., Lohani, S. P., Shrestha, P., & Xue, C. (2024). Expert perspective on

technological choice for cooking energy transition in Nepal. *Clean Energy*, 8(4), 40–48. <https://doi.org/10.1093/ce/zkae035>

K.c., D., Thapa, R. K., Bhandari, R., & Lohani, S. P. (2025). Is induction cooking facing barriers in developing countries? An empirical analysis using people’s perception in Nepal. *Energy for Sustainable Development*, 88, 101814. <https://doi.org/10.1016/j.esd.2025.101814>

LPG Prices. (2025). NOC. <https://noc.org.np/lpg>

National Planning Commission. (2012). National Population and Housing Census 2011. GoN, National Planning Commission Secretariat.

National Statistics Office. (2023). National Population and Housing Census 2021. GoN, National Statistics Office.

Practical Action. (2021). Market Assessment of Efficient Electric Cooking Appliances in Nepal. Modern Energy Cooking Services (MECS). <https://mecs.org.uk/wp-content/uploads/2022/01/Market-Assessment-of-Efficient-Electric-Cooking-Appliances-in-Nepal.pdf>

Procurement of Electric Stove with Various Utensil. (2025). <https://www.nepaltender.com/tender/procurement-electric-stove-various-utensil-750d7a9.php>

Ramirez, C., Khavari, B., Oberholzer, A., Ghimire, B. R., Mishra, B., Sinclair-Lecaros, S., Mentis, D., Gurung, A., Khatiwada, D., & Nerini, F. F. (2024). Achieving Nepal’s clean cooking ambitions: An open source and geospatial cost–benefit analysis. *The Lancet Planetary Health*, 8(10), e754–e765. [https://doi.org/10.1016/S2542-5196\(24\)00209-2](https://doi.org/10.1016/S2542-5196(24)00209-2)

Shrestha, A., Dixit, A., Rimal, N. N., Bhandari, D., Basnet, S., Acharya, D., & Sharma, R. (2024). Electric Cooking in Nepal. Institute for Social and Environment Transition Nepal (ISETN). Accessed on October, 11. https://isetnepal.org.np/wp-content/uploads/2024/11/Electric-Cooking_compressed.pdf

Shrestha, J. N., Raut, D. B., & Shrestha, D. L. (2020). Cooking Cost Comparison using LPG, Rice Cooker, Induction and Infrared cooker. Center for Energy Studies.

Vaidya, A. (2020). Promoting electric cooking in Nepal: Opportunities and Challenges. WECS. (2024). Energy Sector Synopsis Report. GoN, Water and Energy Commission Secretariat (WECS).

APPENDICES A: EXPERIMENT SETUP



Fig 1: Digital Weighing Machine



Fig 2: TP 101 Digital Kitchen Thermometer



Fig 3: Weight measuring of LPG cylinder



Fig 4: Temperature measurement



Fig 5: Stopwatch



Fig 6: WBT on LPG stove

APPENDICES B: DATA SHEET

Burner	Wt. Of LPG (Before)	Wt. of LPG (After)	Time to boil	Initial Temp. (in °C)	Final Temp. (in °C)	Initial mass of (water + pot)	Final mass of (water + pot)
1 Coldstart	22.040	21.850	14m 13s	13.2	97.3	6.05	5.55
1 Hotstart	21.850	21.680	13m 20s	13.4	97.3	6.05	5.55
2 Coldstart	21.680	21.500	16m 15s	13.8	95.5	6.05	5.50
2 Hotstart	21.500	21.340	15m 50s	13.8	95.8	6.05	5.60
3 Coldstart	21.340	21.140	16m 12s	14	97.1	6.05	5.50
3 Hotstart	21.140	20.950	16m 40s	13.9	97	6.05	5.45

APPENDICES C: TECHNICAL SPECIFICATION OF THE COMMERCIAL ELECTRIC INDUCTION COOKTOP WITH VARIOUS UTENSILS



2. Detailed Technical Specifications and Standards.

Page 1 of 4

परिशिष्ट "क"

Technical Specification of Tilting Bratt Pan

S.N.	Parameters	Specifications	Remarks
Product Dimensions			
1	Overall Size (WxDxH)	Min. (55x31x32) Inch	
2	Tank Inner Size (WxDxH)	Min. (30x19.5x11.5) Inch	
Technical Details			
3	Power	Min. 9KW	
4	Voltage	380-400 V AC	
5	Phase	Three Phase	
6	Frequency	50 Hz	
7	Capacity	Min. 110 Ltr	
8	No. of Element	Min. 6 elements each 1.5 KW	
Other Details			
9	Indicator Light	Red, Green, Yellow for indications	
10	Switch	Rotatory Switch for turning on and off	
11	Thermostat	Adjusted temperature controls, ranging from 50° C to 300° C	
12	Control Panel	Simple analog interface for easy adjustment of temperature, tilt and cooking time	
13	Tilting Mechanism	Manual Gear	
14	Features	Frying, Grilling, Sauteing, Simmering and Braising	
Materials			
15	Cover	Min. 1.5mm SS Sheet	
16	Tank Outer Body	Outer Body Constructed with Min. 1mm Thick SS Sheet	
17	Tank Inner Side Body	Constructed with Min. 2mm Thick SS Sheet	
18	Tank Bottom	Min. 10 mm Thick SS Plate	
19	Insulation	Tank Fully insulated with glass wool for heat preservation	
Others			
20	Warranty	Min. 2 years or Provided by OEM whichever is greater	
21	Documents	Operational and Maintenance Manual in english language should be included	
22	Training	Operation and General Maintenance Training Should be Provided	
23	Installation	Initial on-site installation should be provided by supplier	

Technical Specification of Flat Top Induction

S.N.	Parameters	Specifications	Remarks
Product Dimensions			
1	Product dimension (WxDxH)	Min. (530x610x282) mm	
Technical Details			
2	Power	Min. 8KW (8000 watt)	
3	Voltage	380-400 V AC	
4	Phase	Three Phase	
5	Frequency	50 Hz	
6	Power Stage	1-8 Level	
7	Timer Function	10-90 minutes	

Handwritten signature and initials

Handwritten signature

Handwritten signature

Handwritten signature

Handwritten signature and initials

Handwritten signature and initials



Page 2 of 4

S.N.	Parameters	Specifications	Remarks
8	Control Module	Mag-Switch operation with Digital Display	
Materials			
9	Material	Should be high grade Stainless Steel	
10	Panel Type	Should be high grade black tuffon glass with high strength and high temperature resistance	
Others			
11	Standards	ISO or CE or NS or Equivalent	
12	Warranty	Min. 2 years or Provided by OEM whichever is greater	
13	Documents	Operational and Maintenance Manual in english language should be included	
14	Training	Operation and General Maintenance Training Should be Provided	
15	Installation	Initial on-site installation should be provided by supplier	

Technical Specification of Wok Top Induction

S.N.	Parameters	Specifications	Remarks
Product Dimensions			
1	Product dimension (LxBxH)	Min. (530x610x282) mm	
Technical Details			
2	Power	Min. 8KW (8000 watt)	
3	Voltage	380-400 V AC	
4	Phase	Three Phase	
5	Frequency	50 Hz	
6	Power Stage	1-8 Level	
7	Timer Function	10-90 minutes	
8	Control Module	Mag-Switch operation with Digital Display	
Materials			
9	Material	Should be high grade Stainless Steel	
10	Panel Type	Should be high grade black tuffon glass with high strength and high temperature resistance	
Others			
11	Standards	ISO or CE or NS or Equivalent	
12	Warranty	Min. 2 years or Provided by OEM whichever is greater	
13	Documents	Operational and Maintenance Manual in english language should be included	
14	Training	Operation and General Maintenance Training Should be Provided	
15	Installation	Initial on-site installation should be provided by supplier	

Technical Specification of Stock Pot 32 Ltr

S.N.	Parameters	Specifications	Remarks
Product Dimensions			
1	Product dimension	Min. (400x260) mm	
Materials			



S.N.	Parameters	Specifications	Remarks
2	Material	Should be High grade Stainless Steel	
3	Handle	Should be high grade Stainless Steel Material with two sides	
4	Bottom	Min. 5 mm triple bottom (SS430+Aluminium+SS201)	
5	Body Thickness	Min. 1.5 mm	
6	Cover Thickness	Min. 0.9 mm	
Others			
7	Weight	Min. 6.8 Kg	
8	Features	Should work with both LP gas stove and induction	
9	Standards	ISO or CE or NS or Equivalent	
10	Warranty	Min. 2 years or Provided by OEM whichever is greater	

Technical Specification of Stock Pot 58 Ltr

S.N.	Parameters	Specifications	Remarks
Product Dimensions			
1	Product dimension	Min. (500x300) mm	
Materials			
2	Material	Should be High grade Stainless Steel	
3	Handle	Should be high grade Stainless Steel Material with two sides	
4	Bottom	Min. 5mm triple bottom (SS430+Aluminium+SS201)	
5	Body Thickness	Min. 1.5 mm	
6	Cover Thickness	Min. 0.9 mm	
Others			
7	Weight	Min. 10.4 Kg	
8	Features	Should work with both LP gas stove and induction	
9	Standards	ISO or CE or NS or Equivalent	
10	Warranty	Min. 2 years or Provided by OEM whichever is greater	

Technical Specification of Stock Pot 113 Ltr

S.N.	Parameters	Specifications	Remarks
Product Dimensions			
1	Product dimension	Min. (600x400) mm	
Materials			
2	Materials	Should be high grade Stainless Steel	
3	Handle	Should be high grade Stainless Steel Material with two sides	
3	Bottom	Min. 5mm triple bottom (SS430+Aluminium+SS201)	
4	Body Thickness	Min. 1.5 mm	
5	Cover Thickness	Min. 0.9 mm	
Others			
6	Weight	Min. 15.5 Kg	
7	Features	Should work with both LP gas stove and induction	
8	Standards	ISO or CE or NS or Equivalent	
9	Warranty	Min. 2 years or Provided by OEM whichever is greater	



S.N.	Parameters	Specifications	Remarks
Technical Specification of Pressure Cooker (80 Ltr)			
S.N.	Parameters	Specifications	Remarks
Product Dimensions			
1	Diameter	Minimum 50 cm	
2	Height of the top body without handle	Minimum 39.5 cm	
3	Height of the body with handle	Minimum 44.5 cm	
4	Height of the whole set with cover	Minimum 57 cm	
Materials			
5	Materials	Should be High grade Stainless Steel	
6	Handle	Min. 2 handles in the pot body and 2 handles in the cover	
7	Bottom	Min. 4mm thick (SS430+Aluminium+SS201) material	
8	Pot body Thickness	Min. 0.8 mm	
Others			
9	Color	Steel	
10	Weight	Min. 18 Kg	
11	Working Pressure (KPA)	Min. 60 KPA	
12	Accessories	2 pcs pressure limited valve, 1 pcs alarm valve and 1 pcs safety valve	
13	Standards	ISO or CE or NS or Equivalent	
14	Warranty	Min. 2 years or Provided by OEM whichever is greater	
Technical Specification of Induction Based Karai			
S.N.	Parameters	Specifications	Remarks
1	Overall Size	Diameter: 20"	
		Height: 6"	
		Thickness: 18 gauge	
2	Materials	M/S (Mild Steel)	
3	Capacity	17 Ltrs	
4	Design	Both Side Handle	

APPENDICES D: ELECTRICITY BILL OF SUNDARIJAL ARSENAL FOR KARTIK/2082

NEPAL ELCTRICITY AUTHORITY							
Electricity Service TOD Meter Bill							
Consumer's Name :Sundarijal Aarsanal							
Consumer No.	:077.19.2028			Approved Load : 2000			
Consumer ID	:1084			Year/Month : 07/2082			
Address	:Sundarijal ,Sundarijal ,KATHMANDU			Trans.Loss : N			
Meter Status	:Normal						
Time	Cur. Reading	Prev. Reading	Difference	Consumed Unit	Unit Rate	Bill Amount	
Peak	82269	78033	4236	4236	13.50	57,186.00	
Normal	657641	617784	39857	39857	12.25	488,248.25	
Off-Peak	58230	54757	3473	3473	7.15	24,831.95	
						570,266.20	
Demand	Recorded Demand			Billed Demand		Rate	Demand Amount
	Peak	Normal	Off-Peak	Prev. Month	Current Month		
	42.40	522.80	34.00		1000	240.00	240,000.00
Current Month's Bill (In NEPAL Currency)							810,266.20
Current Month's Bill (In Currency)							
Voltage				Miscellaneous Charges			-
Current				Previous Dues			-13,795.00
P.F.				Total Bill Amount (In NEPAL Currency)			796,471.00
Total Bill Amount (In Currency)							

**APPENDICES E: INVITATION FOR BIDS FOR THE PROCUREMENT OF
“ELECTRIC STOVE WITH VARIOUS UTENSIL”**



Invitation for Bids

**Government of Nepal (GoN)
Nepali Army
Directorate of Supply and Transport**

Date of publication: **2082-03-31 BS**

Invitation for Bids No: **NA/DTE/MT/82/83/1**

1. The Directorate of Supply and Transport invites electronic bids from eligible bidders for the procurement of **Electric Stove with Various Utensil** for Nepali Army under National Competitive Bidding – **Single Stage Two Envelope** procedures.
2. Under the Single Stage, Two Envelope Procedure, Bidders are required to submit simultaneously two separate sealed envelopes, one containing (i) the Technical Bid and the other (ii) the Price Bid, both in turn enclosed in one sealed envelope as per the provision of ITB 23 of the Bidding Document.
3. Eligible bidders may obtain further information and inspect the bidding documents at the office of the Directorate of Supply and Transport, Bhadrakali, Kathmandu or may visit PPMO website www.bolpatra.gov.np/egg.
4. Bidder who chooses to submit their bid electronically may download the bidding documents for e-submission from PPMO's e-GP system www.bolpatra.gov.np/egg. Bidders, submitting their bid electronically, should deposit the cost of bidding document in the following Rajaswa (revenue) account as specified below.

Information to deposit the cost of bidding document in Bank:

Name of the Bank: Nepal Bank Ltd, Bhugolpark Kathmandu.

Name of the office: Nepali Army, Directorate of Supply and Transport, Bhadrakali, Kathmandu,

Office Code no.: 345013505

Office Account no.: 0010100000001001001

Rajaswa (revenue) Shirsak no.: 14229

Bidding Fee: Rs 10,000 (Non-refundable)

5. Pre-bid meeting shall be held at the office of **Directorate of Supply and Transport**, Bhadrakali, Kathmandu, Nepal at **1300 hrs** on **2082-04-18 BS**.
6. Electronic bids must be submitted to the office of **Directorate of Supply and Transport**, Bhadrakali, Kathmandu, Nepal through PPMO's e-GP system www.bolpatra.gov.np/egg on or before **1200 hours** on **2082-04-29**. Bids received after this deadline will be rejected.
7. The bids shall be opened at **1300 hrs** at the office of the **Directorate of Supply and Transport** immediately after expiry of the deadline for the submission of bids. Bids must be valid for a period of **120 days** from the date of bid opening and must be accompanied by a bid security or scanned copy of the bid security in pdf format in case of e-bid, amounting to a minimum of NRs. **56,00,000.00**. Which shall be valid for **30 days** beyond the validity period of the bid (i.e.2082-09-27).

Nabin Kumar Mandal

Transitioning from LPG Cooking to Commercial Electric Induction Cooking: A Case Study of Sundarilal Arsenal Barrac...

Submitted by: Nabin Kumar Mandal

Document Details

Submission ID
5117550444269

Submission Date
Jun 29, 2026, 1:22 PM GMT+5:45

Download Date
Jun 29, 2026, 1:27 PM GMT+5:45

File Name
Thesis Final Nabin.docx

File Size
80 KB

67 Pages
13,425 Words
73,476 Characters

16% Overall Similarity

The combined total of all matches, including overlapping sources, for each database.

Filtered from the Report

- Bibliography
- Quoted Text
- Cited Text
- Small Matches (less than 10 words)

Custom Section Exclusions

{titlesCount} Section Titles, {keywordsCount} Keywords

Section title	No. of Section Starters	Section Starters
"Acknowledgements"	4	Acknowledgements Acknowledgement Acknowledgment Acknowledgments

Match Groups

- 79 Not Cited or Quoted 16%**
Matches with neither in-text citation nor quotation marks
- 0 Missing Quotations 0%**
Matches that are still very similar to source material
- 0 Missing Citation 0%**
Matches that have quotation marks, but no in-text citation
- 0 Cited and Quoted 0%**
Matches with in-text citation present, but no quotation marks

Top Sources

- 14% Internet sources
- 5% Publications
- 0% Submitted works (Student Papers)

Integrity Flags

0 Integrity Flags for Review

No suspicious text manipulations found.

Our system's algorithms look deeply at a document for any inconsistencies that would set it apart from a normal submission. If we notice something strange, we flag it for you to review.

A flag is not necessarily an indicator of a problem. However, we'll recommend you focus your attention there for further review.

Match Groups

- **79 Not Cited or Quoted: 16%**
Matches with neither in-text citation nor quotation marks
- **0 Missing Quotations: 0%**
Matches that are still very similar to source material
- **0 Missing Citation: 0%**
Matches that have quotation marks, but no in-text citation
- **0 Cited and Quoted: 0%**
Matches with in-text citation present, but no quotation marks

Top Sources

- 14% Internet sources
- 5% Publications
- 0% Submitted works (Student Papers)

Top Sources

The sources with the highest number of matches within the submission. Overlapping sources will not be displayed.

1	Internet	elibrary.tucl.edu.np	6%
2	Publication	Camilo Ramirez, Babak Khavari, Alicia Oberholzer, Bhoj Raj Ghimire et al. "Achiev...	2%
3	Internet	wecs.gov.np	1%
4	Internet	nepjol.info	1%
5	Internet	www.dtic.mil	<1%
6	Internet	www.mofe.gov.np	<1%
7	Internet	mecs.org.uk	<1%
8	Internet	www.researchgate.net	<1%
9	Internet	isetnepal.org.np	<1%
10	Internet	www.ncbi.nlm.nih.gov	<1%

11	Internet	archive.org	<1%
12	Internet	www.nepjol.info	<1%
13	Internet	www.who.int	<1%
14	Internet	www.hindustantimes.com	<1%
15	Internet	www.nikhef.nl	<1%
16	Internet	data.nsonline.gov.np	<1%
17	Internet	www.udspace.uds.edu.gh	<1%
18	Publication	Dipesh K.C., Rajan Kumar Thapa, Ramchandra Bhandari, Sunil Prasad Lohani. "Is i..."	<1%
19	Internet	etd.aau.edu.et	<1%
20	Internet	afribary.com	<1%
21	Internet	openknowledge.worldbank.org	<1%
22	Internet	giwmscdnone.gov.np	<1%
23	Internet	www.mdpi.com	<1%
24	Publication	Mehmet Ali Cakir, Ramazan Unlu, Sümeýra Cay Cakir, Petros Xanthopoulos. "Futu..."	<1%

25	Internet	
academic.oup.com		<1%
<hr/>		
26	Internet	
www.suaire.sua.ac.tz		<1%

" Transitioning from LPG Cooking to Commercial Electric Induction Cooking: A Case Study of Sundarijal Arsenal Barrack, Kathmandu, Nepal"

Nabin Kumar Mandal ^a, Ajay Kumar Jha ^b

^{a,b} Department of Mechanical and Aerospace Engineering, Pulchowk Campus, Tribhuvan University

^a 076msree008.nabin@pcampus.edu.np, ^b akjha@ioe.edu.np

Abstract

This study presents a practical framework for transitioning cooking practice at the Sundarijal Arsenal Barrack from LPG to electric induction cooking. The transition is motivated by rising LPG prices, dependence on imported LPG, and the increasing availability of clean, domestically generated electricity. Large institutional kitchens such as army barracks consume substantial amounts of fuel daily, so improving cooking efficiency can result in significant financial and environmental benefits. The study first analyzes the existing LPG-based cooking system. Data were collected through field visits, direct observations, and interviews with kitchen staff and technical personnel. The barrack serves approximately 252 personnel daily and consumes about 5,296.6 kg of LPG per year. This provides a total energy input of 67,690.55 kWh annually. However, due to the low thermal efficiency of LPG stoves, only around 36% of this energy is effectively utilized for cooking. Consequently, the energy consumption per person is high, at 268.6 kWh per year. To replace LPG cooking, the required capacity of commercial induction cooktops and the existing electrical infrastructure were assessed. The analysis shows that an induction capacity of about 25 kW is sufficient and can be supported by the available three-phase electricity supply. The proposed induction system consumes around 85 kWh per day, or 31,025 kWh per year, assuming two cooking sessions per day. This reduces energy consumption per person to 123.11 kWh per year, which is less than half of the LPG-based system. A financial analysis comparing LPG and induction cooking shows strong economic viability. The barrack currently spends approximately NPR 7,12,430 per year on LPG, while the annual electricity cost for induction cooking is about NPR 3,80,056.25. The total investment cost is around NPR 11,20,000, with a simple payback period of 3.75 years, an internal rate of return of 23.425%, and a net present value of NPR 7,15,835.36 over a time period of ten years. Environmentally, the transition reduces CO₂ emissions by about 15.8 tonnes per year, equivalent to 62.7 kg per person annually. Overall, the study confirms that induction cooking is a technically feasible, financially viable, and environmentally sustainable primary cooking solution for the Sundarijal Arsenal barrack as well as for the other Nepali Army units and is also suitable for large commercial kitchens like security personnel barracks, hostel, banquet, hotel, etc.

Keywords

Sundarijal Arsenal, Induction Cooking, LPG, Clean Cooking

1. Introduction

As of 2022, approximately 2.1 billion people worldwide lack access to clean cooking facilities, contributing to an estimated 3.2 million premature deaths annually due to household air pollution (HAP). In Nepal, the energy landscape remains dominated by the residential sector, which accounts for 60.75% of total energy consumption. Despite national efforts, nearly 79.52% of residential energy is still derived from fuelwood, while modern cleaner sources like electricity (4.99%) and biogas (3.31%) remain underutilized. Furthermore, the Ministry of Energy, Water Resources, and Irrigation

(MoEWRI) aims to increase per capita electricity consumption to 700 kWh in the next five years and 1,500 kWh within ten years [1]. Nepal possess abundant hydropower potential that offers a pathway to energy security. The Government of Nepal's Second Nationally Determined Contribution (NDC) set an ambitious target of ensuring 25% of households adopt electric cooking (e-cooking) by 2030 [2]. The heavy reliance on traditional biomass not only poses severe health risks leading to over 22,500 premature deaths annually in Nepal but also creates an economic burden through the massive import of Liquefied Petroleum Gas (LPG). There has been a dramatic rise in LPG adoption, jumping from 21.03% in 2011 to 44.3% in 2021 according to the respective census data [3] [4].

The cumulative number of households that adopt various primary cooking options from 2020 to 2030 in the ambitious e-cooking scenario while also taking into account population growth shows that the number of households using electric cookstoves is projected to rise sharply, from 3,73,605 in 2020 to 18,53,146 by 2030. The use of biogas cookstoves also increases steadily, from 6,84,942 households in 2020 to 11,86,013 in 2030. In contrast, households using LPG cookstoves remain almost unchanged, between about 3.17 and 3.28 million from 2020 to 2028, but then fall sharply to 335,662 by 2030. This change suggests a planned reduction or replacement of LPG with cleaner cooking options [5]. WECS has developed the hierarchy of different cookstoves and fuels used in Nepal based on their thermal efficiency and shows electric cookstove as the most efficient and cleanest cooking solution. Also, the overall hierarchy of cooking technology choices in Nepal shows the induction stove was the best choice with 23.3% weightage priority and was therefore ranked first among nine cooking technologies. Induction stoves are the most favored, with a weight of 23.3%, followed by hot plates at 16.9%. LPG stoves (15.1%) and biogas stoves (14.7%) are also significant, indicating that both electric and gas-based cooking solutions are widely valued. Among alternative and traditional technologies, parabolic solar cookers (7.5%), 3 pot hole metallic improved cookstoves (ICS) (6.1%), beehive briquette stoves (5.6%), Bayupankhi stoves (5.3%), and 2 pot hole mud ICS (5.2%) are less prominent. Efficiency and capital cost are key determinants in choosing cooking technologies in Nepal, with efficiency being the most influential factor, followed by capital cost. The study identified induction stoves as the top choice. Therefore, promoting electric cooking, especially induction stoves, is recommended to drive a transition to clean cooking [6]. An experiment conducted as a comparison of the cost, time, and energy consumption involved in cooking rice using LPG, coil heaters, rice cookers, induction cookers, and infrared cookers. The results revealed that induction cookers can reduce costs by up to 42% compared to LPG [7]. Electric cooking is another alternative which is becoming one of the potential clean cooking solutions in Nepal. The policy of electric cooking promotion is in the best interest of Nepal both at macro and microeconomic levels. An increase in the production of electric power and electrification rates is expected in the future, which means that facilitation of electric cooking has significant opportunities [8]. The government policy and programs are significant in the switch to electric cooking. The Nepal Ministry of Energy, Water Resources and Irrigation (MoEWRI), which has appreciated how hydropower can be used in two ways namely giving access to modern energy as well as clean cooking source, has published a white paper regarding the Electric Stove in Every House Program, which will likely stimulate electric cooking. It not only offers an opportunity to use the hydropower resources in Nepal, but also to decrease its reliance on imported fossil fuel. Based on the learning from other countries and with proper policy, programmes and access to technology, can help Nepal to transition from LPG to electric

cooking in urban areas and solid fuels to electricity in rural areas [9]. A key element in maintaining operational readiness and the physical fitness of soldiers is the regular provision of nutritious and safe meals. However, traditional cooking practices in Nepal, particularly in institutional settings, often depend on biomass fuels and inefficient stoves, which pose significant health risks, contribute to environmental degradation, and expose kitchen staff and soldiers to harmful indoor air pollution [10]. Despite a design of 40 m³ biogas plant to replace partial LPG fuel in cooking, the plant operates only 22% of its capacity meeting only 3% of cooking demand, with contribution of maximum 13.7% cooking demand at its design capacity [11]. Adoption of electric rice cookers in Nepali Army showed the positive outcomes in terms of energy efficiency and cost benefits with the cost of steamer cooking only 35 percent of that of LPG cooking per kg of rice cooked [12].

According to Nepal Foreign Trade Statistics (NFTS) data for FY 2079/80, LPG gas ranked 3rd in the most imported commodities. The Nepali Army, one of the nation's oldest and most pivotal security forces, reflects the broader national energy evolution. Since the government began providing ration facilities in 1951, cooking practices have transitioned through three distinct phases: The Biomass Era: Initially dependent on wood, which was unsustainable and labor-intensive. The Kerosene Transition (2006): A shift aimed at reducing deforestation, though hampered by high import costs and volatility. The LPG Standard (2015): The current primary fuel source, providing efficiency but creating heavy dependence on imported fossil fuels. Currently, the Nepali Army supports over 90,000 active personnel, spending approximately NPR 552 million annually on LPG. Because of the LPG dependence, it becomes vulnerable to supply disruptions, external political uncertainties, and a heavy financial burden. The objective of the research is to assess the feasibility and impact of transitioning from LPG cooking to electric induction cooking in the Sundarijal Arsenal army barrack, Kathmandu, Nepal.

2. Methodology

This study used a step-by-step process to evaluate the shift from LPG cooking to commercial electric induction cooking at the Sundarijal Arsenal barrack. The work begins with a technical assessment, where the performance, energy demand, electric load distribution and practicality of induction cooking are examined. After that, financial and environmental analysis is carried out to compare costs, emissions, and long-term benefits against the current LPG system. The study then brings all these results together to give a clear sustainability picture towards transition from LPG to induction cooking. The methodology used during the study is shown in figure 1.

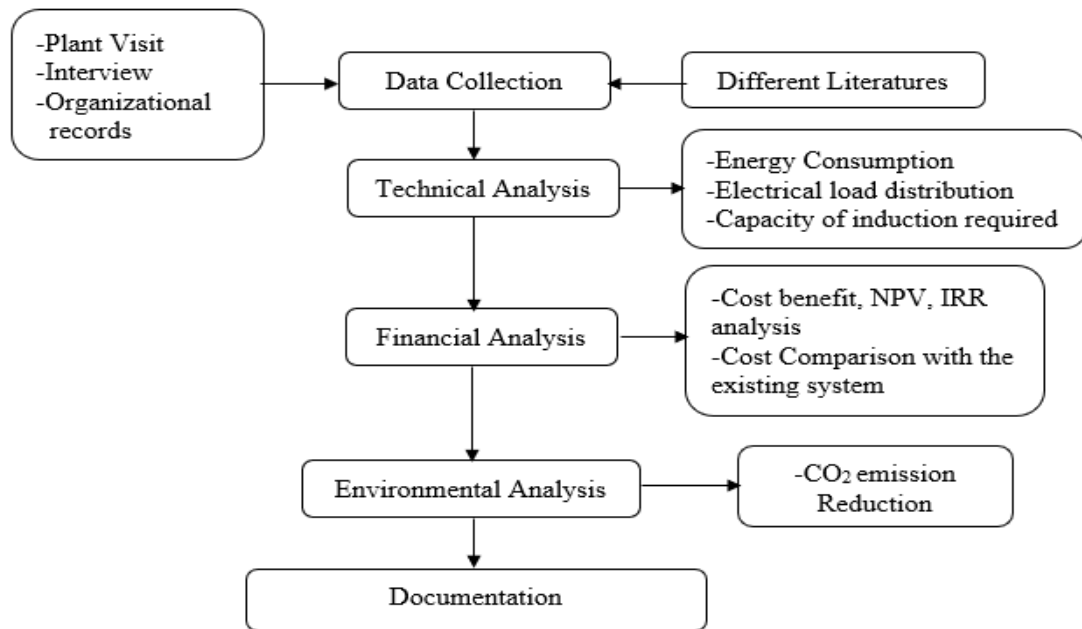

Figure 1: Research Methodology Flowchart

2.1 Materials and Methods

Data collection is one of the most important aspect of any research which helps to determine the quality and output of any research. The study was performed by taking the useful and relevant data from the Sundarijal Arsenal barrack situated in Gokarneshwor Municipality, Kathmandu. Primary data were collected through direct observations and interview to the relevant personnel. The focus areas included the Annual LPG consumption, the availability of 3-phase electricity and the institutional plan for adopting induction based cooking.

The technical analysis began with the assessment of annual LPG consumption using organizational records. LPG consumption was converted into energy terms using the calorific value of LPG, and the actual useful cooking energy was determined by experimentally measuring the thermal efficiency of LPG stoves through the Water Boiling Test, adapted from Water Boiling Test Version 4.2.3. Using the measured efficiency, the useful annual and daily cooking energy demand was calculated. The required induction cooking capacity was then estimated based on cooking duration and adjusted for induction efficiency. An electrical load analysis was carried out to verify the compatibility of the proposed induction system with the existing three-phase electrical infrastructure by evaluating current demand and protection devices. The formulae used during the technical analysis are summarized below:

$$\text{Total LPG consumption (kg/year)} = \text{Number of cylinders} \times \text{LPG per cylinder} \quad \dots(1)$$

$$\text{Total energy from LPG (kWh/year)} = \text{Total LPG consumption} \times \text{Calorific value of LPG} \quad \dots(2)$$

$$\text{Useful energy from LPG (kWh/year)} = \text{Total energy from LPG} \times \text{Thermal efficiency} \quad \dots(3)$$

$$\text{Required induction capacity (kW)} = \frac{\text{Total energy consumption per session (kWh)}}{\text{Cooking duration (hours)}} \quad \dots(4)$$

$$\text{Actual induction capacity required (kW)} = \frac{\text{Required induction capacity}}{\text{Induction efficiency}} \quad \dots(5)$$

$$\text{Annual electricity consumption (kWh/year)} = \text{Daily electricity consumption} \times 365 \quad \dots(6)$$

The financial analysis evaluated the economic viability of the transition using standard investment appraisal techniques, including simple payback period, net present value (NPV), and internal rate of return (IRR). Capital cost, operating cost, and annual savings from reduced LPG consumption were considered to assess long-term financial performance.

$$\text{Payback Period} = \frac{\text{Cost Of Investment}}{\text{Average Annual Cash Flow}} \dots\dots\dots (7)$$

$$\text{NPV} = -C_0 + \sum_0^N \frac{C}{(1+d)^N} \dots\dots\dots (8)$$

$$\left(\frac{CF1}{(1+r)^1} + \frac{CF2}{(1+r)^2} - \frac{CF3}{(1+r)^3} + \dots \right) - \text{Initial Investment} = 0 \dots\dots\dots (9)$$

The environmental analysis quantified the reduction in carbon dioxide emissions resulting from LPG replacement. CO₂ emission savings were estimated using standard emission conversion factors, and the associated economic value of emission reduction was also calculated.

$$\text{CO}_2 \text{ saved} = \text{LPG saved} \times 2.98 \text{ kg of CO}_2 \dots\dots\dots (10)$$

$$\text{Rate of Per tons of CO}_2 \text{ Equivalent} = 7 \text{ USD} \dots\dots\dots (11)$$

Finally, a comparative analysis was conducted between the existing LPG cooking system and the proposed induction cooking system. Key indicators such as energy consumption per capita, cooking cost per capita, and CO₂ emissions were compared to determine the overall feasibility and sustainability of the transition.

3. Result and Discussion

This chapter presents all the recorded data and findings, and it also evaluates them according to the framework shown in the methodology. All necessary calculations are performed using the formula specified in the methodology.

3.1 Technical Analysis

In this chapter, different calculations and technical analysis were carried out.

Annual LPG Consumption The monthly LPG consumption data shows that a total of 373 LPG cylinders are used annually in the Sundarijal Arsenal barrack kitchen. This reflects a high dependence on LPG for daily cooking activities.

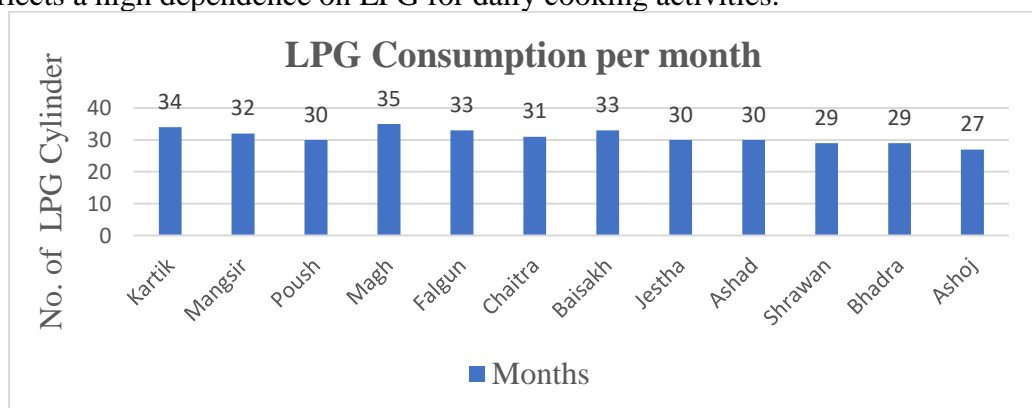

Figure 2: LPG Consumption Chart

Thermal Efficiency of LPG Cooking Stove

Since Nepal does not have officially established standards for testing the thermal efficiency of cooking stoves, the Water Boiling Test (WBT) method was adopted based on Water Boiling Test Version 4.2.3. This method is widely used and provides reliable results for comparing stove performance. The Sundarijal Arsenal kitchen uses two commercial heavy-duty LPG systems: one with two burners and another with a single burner, making a total of three burners. For each set of tests, a 10-liter pot was filled with 5 kg of water. The high power cold start and high power hot start phase was used to evaluate the thermal efficiency of LPG cooking stove. Each burner was tested separately under similar conditions. The weight are measured using the digital weighing machine while the temperature was measured using TP 101 digital kitchen thermometer with long probe having accuracy of $\pm 1^{\circ}\text{C}$ and temperature measurement range of -50°C to $+300^{\circ}\text{C}$. In each burner, the hot start efficiency is higher than the cold start efficiency. Burner 2 shows maximum thermal efficiency for both cold start and hot start meanwhile burner 3 illustrate minimum thermal efficiency. The results are presented in the table 1.

Burner	Thermal Efficiency		Average
	Cold Start	Hot Start	
1	33.96	37.90	35.93
2	36.58	38.16	37.37
3	33.25	36.30	34.78
Average Thermal Efficiency			36.02% \approx 36%

Table 1: Thermal efficiency of LPG cooking stove

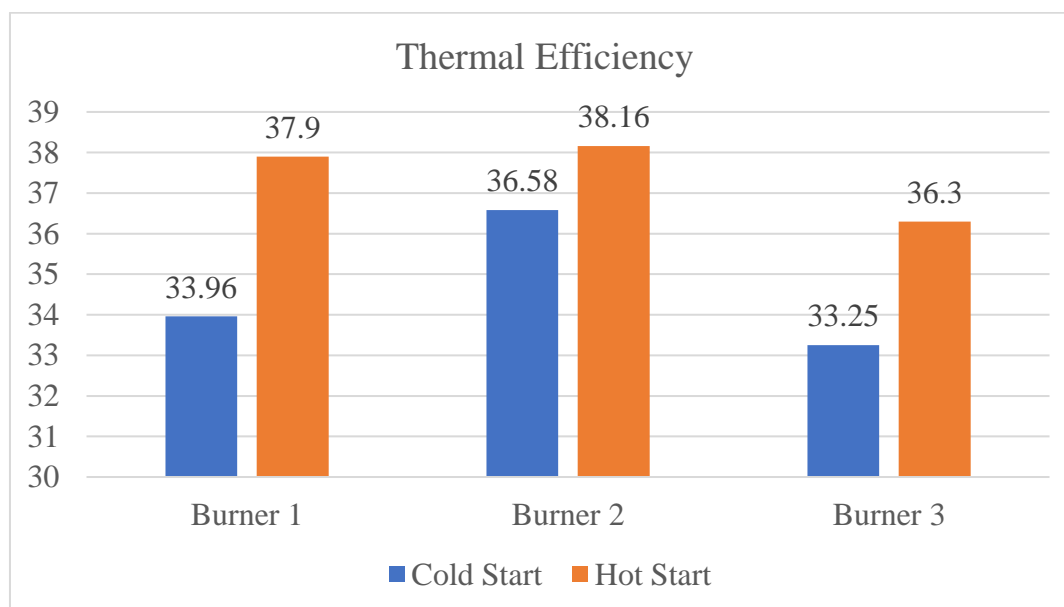

Figure 3: Thermal efficiency comparison of burners in different high power phase

Useful Energy from LPG Cooking System

The Useful Energy from the LPG cooking system is calculated as:

Total mass of LPG (kg/year) = $373 \times 14.2 \text{ kg} = 5296.6 \text{ kg}$

Thermal efficiency of LPG stove = 30% (from experiment)

Total energy from LPG cooking system (kWh/year) = $5296.6 \times 12.78 = 67,690.55 \text{ kWh}$

Useful energy from LPG (kWh/year) = $67,690.55 \times 0.36 = 24,368.60 \text{ kWh}$

Daily Useful energy from LPG (kWh/day) = $24368.60/365$ (Taking 1 year = 365 days)
= $66.76 \text{ kWh} \approx 67 \text{ kWh}$

Daily Useful energy from LPG (kWh/session) = $67/2$ (Taking 2 sessions per day) = 33.5 kWh

Based on the annual LPG consumption of 5,296.6 kg, the total energy supplied by LPG is 67,690.55 kWh per year. Considering the measured thermal efficiency of 36%, the actual useful energy available for cooking is 24,368.60 kWh per year.

Total Cooking Energy Consumption in the Barrack

LPG is mainly for cooking curries, lentils, vegetables, and meat & electricity is used only for the rice steamer. The total energy consumption per cooking session is 42.5 kWh (LPG 33.5 kWh and electricity 9 kWh).

Required Capacity of Induction Cooking System

The total energy consumption per session (morning & evening) per day is 42.5 kWh.

The required capacity of induction cooktop is calculated as:

Total Induction Capacity required = Daily energy consumption / Cooking hours per day
= $42.5/2$ (Taking 2 hours of cooking time per session)
= 21.25 kW

Efficiency of Induction Cooktop = 85% (Avg.) [13]

Required Capacity of Commercial Induction Cooktop = Total induction capacity required / Efficiency of induction cooktop
= $21.25/0.85 = 25 \text{ kW}$

This shows that a commercial induction system of around 25 kW is sufficient to meet the cooking energy demand of the barrack.

Electrical Load distribution in the barrack

The Sundarijal Arsenal barrack is supplied by three transformers with a combined capacity of 2000 kVA, which matches the approved load provided by the Nepal Electricity Authority. The kitchen rice steamer is currently connected using a 10 mm², 4-core XLPE cable with an 80 A MCB.

However, according to IEC standards, the maximum safe current capacity of this cable is 71 A, which means the existing 80 A MCB is oversized. For the proposed induction cooking system of 27 kW, the calculated three-phase current is 51.3 A. Therefore, replacing the existing MCB with a 63 A MCB is both safe and appropriate, and no cable replacement is required.

This confirms that the existing electrical infrastructure can support the induction cooking system with minor modifications. For this purpose, around NRs. 1.1 million has been allocated for 200 units of Nepali Army to procure eight types of cooking utensils, including induction stoves, for implementing induction-based cooking [14].

The list of the items are shown in the table 2.

S.No.	Item	Unit	Quantity	Remarks
1	Tilting Bratt Pan (9 kW/110L)	Set	1	
2	Flat Top Induction (9 kW)	Set	1	
3	Wok Top Induction (9 kW)	Set	1	
4	Induction Based Stock Pot (113L)	Set	1	
5	Induction Based Stock Pot (58L)	Set	1	
6	Induction Based Stock Pot (32L)	Set	1	
7	Induction Based Pressure Cooker (80L)	Set	1	
8	Induction Based Karai (17L)	Set	1	

Table 2: List of Cooking Utensils including Induction Stove

Barrack Population Trend

Population data over the last 10 years shows that the number of personnel remained stable until 2078 BS, after which a sharp decline occurred. Since 2079 BS, the population has stabilized at 252 personnel.

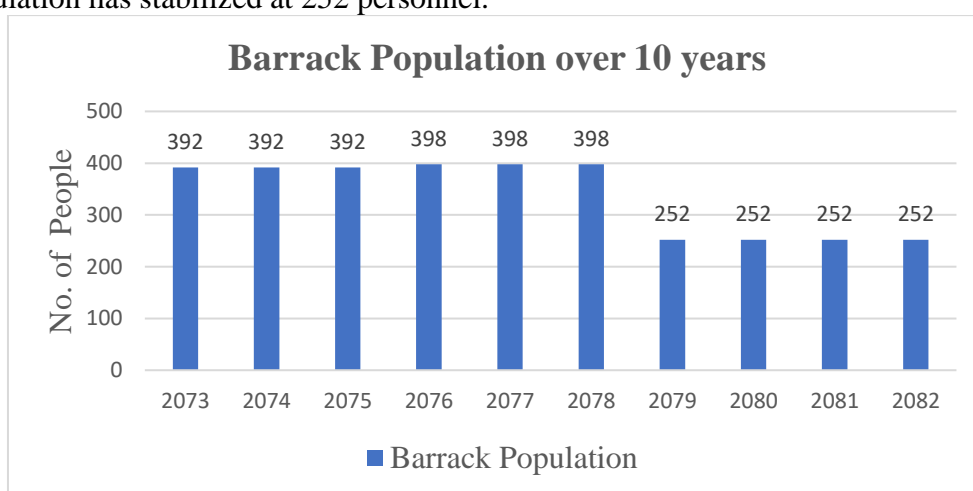

Figure 4: Barrack Population over 10 years

The population is decreasing at an average rate of 4.32% per year, and no future increase is expected. Therefore, installing an induction cooking system sized for the current population is technically appropriate and does not risk future expansion.

3.2 Financial Analysis

The financial feasibility of replacing LPG with induction cooking was evaluated using payback period, IRR, and NPV. The estimated cost of one complete induction cooking unit is NPR 11,20,000. Compared to the annual LPG cost of NPR 7,12,430, the annual electricity cost for induction cooking is only NPR 3,80,056.25.

Total Cost of Electric Induction Cooktop with utensils	NPR 11,20,000	
Annual Maintenance cost	NPR 33,600	Taking 3% of total cost
Daily Electricity Consumption	85 kWh	42.5 kWh per session @ 2 sessions per day
Total Annual Electricity Consumption	31,025 kWh	Taking 365 days per year
Total Annual Electricity Cost	NPR 3,80,056.25	NPR 12.25 during normal time
Total cost saving from LPG	NPR 7,12,430	373 cylinders @ NPR 1910 per cylinder (<i>LPG Prices, 2025</i>)
Total net cost savings	NPR 2,98,773.75	Total cost saving from LPG- Total Annual Electricity Cost-Annual Maintenance cost
Time period (Shelf life)	10 years	(10-15) years (AT Cooker, 2025)
Simple payback period	3.75 years	
IRR	23.425%	
NPV	NPR 7,15,835.36	@10%

Table 3: Financial Analysis

3.3 Environmental Analysis

LPG combustion releases greenhouse gases, mainly CO₂, which contribute to climate change and indoor air pollution. By fully replacing LPG with electric induction cooking, the barrack can avoid 15.8 tons of CO₂ emissions per year.

Calculation of CO ₂ Equivalent from LPG savings		
Total Weight of LPG Saving / annum	5296.6	Kg
Conversion Factor	2.98	Kg of CO ₂ Equivalent [11]
Total CO ₂ Equivalent / annum	15.8	Tons of CO ₂ Equivalent [11]
Rate of Per tonnes of CO ₂ Equivalent	7	USD
Total Cost Saving	110.6	USD per Annum
Total Cost Saving (NPR)	15,989.4	1USD = NPR 144.57

Table 4: Calculation of CO₂ Equivalent from LPG savings as well the total cost savings

The corresponding carbon cost saving is approximately NPR 15,989.4 per year. Although the monetary value is relatively small, the environmental and health benefits are significant, especially in enclosed kitchen environments.

3.4 Comparison with the existing LPG cooking system

The energy use per capita for LPG cooking is 268.6 kWh/year, while for induction cooking it is only 123.11 kWh/year. This shows that induction cooking uses less than half the energy per person, mainly due to its higher efficiency. The annual cost per person for LPG cooking is NPR 2,827 whereas for induction cooking it is NPR 1,508.16. This represents a substantial reduction in cooking energy expenses. From an environmental perspective, the transition to induction cooking reduces CO₂ emissions by about 15.8 tonnes per year, which is equivalent to 62.7 kg of CO₂ per person annually with a per capita cost of NPR 63.45 per year.

4. Conclusions

The existing LPG cooking system at the Sundarijal Arsenal barrack is costly, inefficient, and highly dependent on imported fuel. Although a large amount of LPG is consumed every year, the useful energy obtained is low due to the stove's average efficiency of only 36%. This makes the current system economically and energetically inefficient. The study shows that commercial induction cooking is a better alternative for institutional kitchens. Induction cooking is more efficient, safer, and easier to control. The required induction capacity for the barrack is about 25 kW, which can be supported by the existing electrical infrastructure with minor adjustments. Even after including electricity and maintenance costs, induction cooking results in substantial annual savings compared to LPG. The financial analysis confirms the economic feasibility of the transition. The system has a payback period of 3.75 years, an IRR of 23.425%, and a positive NPV of NPR 7,15,835.36, making it a financially sound investment. From an energy and environmental perspective, LPG cooking consumes 268.6 kWh per person per year, whereas induction cooking requires only 123.11 kWh per person per year. The cost per capita decreases from NPR 2,827.1/year for LPG to NPR 1,508.16/year for induction. In addition, induction cooking reduces 62.7 kg of CO₂ emissions per person per year, with a carbon cost saving of NPR 63.45 per person per year. Overall, the transition from LPG to induction cooking is technically feasible, financially viable, and environmentally beneficial. It also reduces Nepal's dependence on imported LPG by promoting the use of locally generated hydropower. Therefore, induction cooking is a practical and sustainable solution for the Sundarijal Arsenal barrack as well as for the other Nepali Army units and is also suitable for large commercial kitchens like security personnel barracks, hostel, banquet, hotel, etc.

5. References

- [1] WECS. (2024). Energy Sector Synopsis Report. GoN, Water and Energy Commission Secretariat (WECS).
- [2] GoN. (2020). Second Nationally Determined Contribution (NDC). Government of Nepal (GoN).
- [3] National Planning Commission. (2012). National Population and Housing Census 2011. GoN, National Planning Commission Secretariat.
- [4] National Statistics Office. (2023). National Population and Housing Census 2021. GoN, National Statistics Office.
- [5] Climate Change Management Division. (2021). Assessment of Electric Cooking Targets for Nepal's 2020 Nationally Determined Contributions (NDC). MoFE, GoN.
- [6] KC, D., Lohani, S. P., Shrestha, P., & Xue, C. (2024). Expert perspective on technological choice for cooking energy transition in Nepal. *Clean Energy*, 8(4), 40–48. <https://doi.org/10.1093/ce/zkae035>

- [7] Shrestha, J. N., Raut, D. B., & Shrestha, D. L. (2020). Cooking Cost Comparison using LPG, Rice Cooker, Induction and Infrared cooker. Center for Energy Studies.
- [8] Vaidya, A. (2020). Promoting electric cooking in Nepal: Opportunities and Challenges.
- [9] Kafle, S., Mishra, A. K., Maharjan, A., & Panday, A. K. (2019). Moving from Fossil Fuels to Electric Cooking: An Option for Clean Cooking Access in Nepal. *Journal of the Institute of Engineering*, 15(3), 159.
- [10] Karmacharya, S. (2023). Practices of institutional meal in Armed Police Force, Nepal. <https://elibrary.tucl.edu.np/items/0b8e77aa-8e52-40e3-8679-71c1530f3dc8>
- [11] Ghimire, M. K. (2025). Sustainability Assessment of Institutional Biogas Plant in Nepal- A Case Study of Sundarijal Arsenal Biogas Plant. <https://elibrary.tucl.edu.np/items/4fd350c0-b027-4ff3-b16f-65e250b0ff12>
- [12] Batajoo, M. (2023). Performance and Financial Analysis of Replacing LPG Stoves by Electric Rice Steamers for Rice Cooking: A case study of Nepali Army (Swayambhu Baroodkhana Karyalaya). <https://elibrary.tucl.edu.np/items/9dad6925-08ed-44cd-a065-f28cefb7a9d8>
- [13] Darlami, H. B., Chaudhary, R., & Budha, B. K. (2020). Cooking Devices and their Thermal Efficiencies in the Context of Nepal: A Review. 07(11).
- [14] Procurement of Electric Stove with Various Utensil. (2025). <https://www.nepaltender.com/tender/procurement-electric-stove-various-utensil-750d7a9.php>
- [15] LPG Prices. (2025). NOC. <https://noc.org.np/lpg>
- [16] AT Cooker. (2025). Commercial Induction Stove Durability: 10-15 Year Lifespan | AT Cooker. A Professional Cooking Equipment Manufacturer & Exporter. <https://www.atcooker.com/commercial-induction-stove-durability-lifespan/>