



**TRIBHUVAN UNIVERSITY
INSTITUTE OF ENGINEERING
PULCHOWK CAMPUS
DEPARTMENT OF CIVIL ENGINEERING**

**FINAL YEAR PROJECT REPORT
on
“EARTHQUAKE RESISTANT ANALYSIS AND DESIGN OF MULTIPURPOSE
BUILDING”**

By:

Prakrit Devkota	075BCE101
Priyanshu Pokhrel	075BCE109
Ram Krishna Kandel	075BCE116
Rijab Ali Miya	075BCE119
Safal Katwal	075BCE129
Sangam Poudel	075BCE142

Supervisor:

Asst. Prof. Aakarsha Khawas

May 2023



**TRIBHUVAN UNIVERSITY
INSTITUTE OF ENGINEERING
PULCHOWK CAMPUS
DEPARTMENT OF CIVIL ENGINEERING**

**FINAL YEAR PROJECT REPORT on
“EARTHQUAKE RESISTANT ANALYSIS AND DESIGN OF MULTIPURPOSE
BUILDING”
IN PARTIAL FULFILLMENT OF THE REQUIREMENT FOR THE AWARD OF
BACHELOR’S DEGREE IN CIVIL ENGINEERING
(Course Code: CE755)**

By:

Prakrit Devkota	075BCE101
Priyanshu Pokhrel	075BCE109
Ram Krishna Kandel	075BCE116
Rijab Ali Miya	075BCE119
Safal Katwal	075BCE129
Sangam Poudel	075BCE142

Supervisor:

Asst. Prof. Aakarsha Khawas

May 2023

COPYRIGHT

The authors have consented that this paper may be inspected for free in the Institute of Engineering's Pulchowk Campus library. Furthermore, the writers have agreed that significant copying of portions of this final year report can only be done with the approval of the authors' project supervisor or, in their absence, the director of the department where the final year project was completed. While replicating the theory, outcomes, and/or any other component of this report, and extending the findings of this project work, correct acknowledgments to the authors and project supervisor should be made. It is forbidden to copy or publish this final year project for profit without the explicit consent of the Department of Civil Engineering, Institute of Engineering, and authors.

Request for permission to copy or to make any other use of findings of this report shall be addressed to:

Head of the Department
Department of Civil Engineering
Pulchowk Campus
Institute of Engineering
Lalitpur, Nepal

Authors:

Prakrit Devkota (075BCE101)
Priyanshu Pokhrel (075BCE109)
Ram Krishna Kandel (075BCE116)
Rijab Ali Miya (075BCE119)
Safal Katwal (075BCE129)
Sangam Poudel (075BCE142)



**TRIBHUVAN UNIVERSITY
INSTITUTE OF ENGINEERING
PULCHOWK CAMPUS
DEPARTMENT OF CIVIL ENGINEERING**

CERTIFICATE

This is to certify that this project work entitled “**EARTHQUAKE RESISTANT ANALYSIS AND DESIGN OF MULTIPURPOSE BUILDING**” has been examined and declared successful for the fulfillment of academic requirements towards the completion of a Bachelor’s Degree in Civil Engineering.

Project Supervisor
Asst. Prof. Aakarsha Khawas

HOD, Department of Civil Engineering
Prof. Dr. Gokarna Bahadur Motra

External Examiner
Prof. Dr. Hari D. Shrestha

Internal Examiner
Asst. Prof. Sunita Ghimire

ACKNOWLEDGEMENT

We would like to convey our sincerest gratitude to our project supervisor, Asst. Prof. Aakarsha Khawas, Department of Civil Engineering, Institute of Engineering, Pulchowk Campus. With her proficient guidance, incisive comments, contingent support, technical expertise, and persistent encouragement, we have been able to complete the project with a certain level of dedication and efficiency. Her experienced approach to any kind of structural analysis and design based on a practical approach has been insightful for us in developing a methodical platform to identify the problem and achieve the best possible solution with regard to available variables. We are truly indebted to her.

We are thankful to the Institute of Engineering in regard to the inclusion of the project work in the final year as an integral part of the curriculum. Furthermore, we would also like to express our gratefulness to the faculty of the Department of Civil Engineering, Pulchowk Campus for their tremendous support and guidance throughout the course of the project. We have attempted to incorporate their comments, suggestions, and bits of advice into our work to the best of our ability.

Finally, we would like to thank all the professors and lecturers of Pulchowk Campus who have directly or indirectly helped us over the duration of our project in different ways, including but not limited to, operating ETABS, and AutoCAD and understanding codes and design practices in the completion of this project work.

Prakrit Devkota (075BCE101)

Priyanshu Pokhrel (075BCE109)

Ram Krishna Kandel (075BCE116)

Rijab Ali Miya (075BCE119)

Safal Katwal (075BCE129)

Sangam Poudel (075BCE142)

ABSTRACT

In the final semester of the curriculum of Bachelor's in Civil Engineering offered by Tribhuvan University, Institute of Engineering (IoE), an integral part of the course is the project work whereby the students are expected to implement their theoretical knowledge acquired in the span of the four years in Bachelor's, to various practical field. The projects can be along a wide spectrum of areas of Civil Engineering, which may be allocated by the institute or may be selected by the students themselves. Earthquakes have been one of the more significant factors that have a direct impact on the design of multi-storeyed frame buildings in seismically active earthquake-prone zones like Nepal. The aftermath of the Gorkha Earthquake in Baishakh 12, 2072 has created a scenario where more consideration has been given to proper earthquake-resistant design in Nepal. The damage incurred in the earthquake caused unprecedented loss during this time, and an attempt is to be made to minimize the disastrous impacts of such earthquakes in the future through proper design techniques. While it is not feasible to construct a completely earthquake-proof structure, emphasis is to be put on Earthquake Resistant Design. The project Earthquake Resistant Design of Commercial Building is chosen with the hope that the concerned parties are more aware of the concept of earthquake-resistant design in order to ensure adequate safety of both life and property.

This project work has been undertaken for the partial fulfillment of requirements for the Bachelor's Degree in Civil Engineering. This project work contains structural analysis, design, and detailing of a commercial building. All the theoretical knowledge on analysis and design acquired during the course works is utilized with practical application. The main objective of the project work is to acquaint us with the practical aspects of Civil Engineering. This report has been prepared by presenting all the works regarding analysis, design, and structural detailing of RCC framed structure including practically possible seismic considerations in a simple, clear, and concise manner. The advanced software: ETABS and AUTOCAD have been used for the analysis and detailing of structure, respectively. Manually prepared software on MS Excel has been used to design beams and columns. In addition, a step-by-step procedure of the manual has also been used to understand the structural action and it is followed to prepare the report.

TABLE OF CONTENTS

COPYRIGHT.....	i
CERTIFICATE.....	ii
ACKNOWLEDGEMENT.....	iii
ABSTRACT.....	iv
LIST OF TABLES.....	viii
LIST OF FIGURES.....	x
NOTATIONS.....	xi
ABBREVIATIONS.....	xiii
1. INTRODUCTION.....	14
1.1 Background.....	14
1.2 Title and Theme of Project.....	15
1.3 Objectives.....	15
1.4 Salient Features.....	15
1.4.1 Methods of Analysis.....	17
1.4.2 Design.....	17
1.5 Limitations of the Project.....	17
2. ASPECTS OF SEISMIC PERFORMANCE AND BUILDING DESCRIPTION.....	18
2.1 Seismic Performance of Building.....	18
2.2 Structural Layout.....	18
2.3 General Principles for the Design.....	19
2.4 Terminology.....	20
3. DESIGN METHODS.....	21
3.1 Understanding and Design Philosophy.....	21
3.2 Design Philosophies.....	21
3.3.1 Design loads.....	24

3.3.2	Load assessment.....	25
3.4.1	Lateral Load Assessment	27
4.	PRELIMINARY DESIGN.....	31
4.1	Preliminary Design of Slab	31
4.2	Preliminary Design of Beam	33
4.2.1	Preliminary design of Primary beam	33
4.2.2	Preliminary design of Secondary beam	37
4.3	Preliminary Design of Column	37
5.	MODELING AND ANALYSIS IN ETABS.....	42
6.	CALCULATIONS.....	45
6.1	Seismic Gap Calculation.....	45
6.2	Soft Storey Check	45
6.3	Eccentricity Check	46
6.4	Calculation of Design Eccentricity	47
6.5	Storey Drift Check	50
6.6	Torsional Irregularity Check.....	51
6.7	Modal Analysis Results	52
7.	STRUCTURAL DESIGN.....	55
7.1	Design of structural elements.....	55
7.2	Design of Slab.....	55
7.3	Design of Beam.....	67
7.4	Design of Columns	91
7.5	Design of Staircase	107
7.6	Design of Basement Wall	116
7.7	Design of Lift Core Wall	121
7.8	Design of Mat foundation	126
7.9	Design of Ramp Slab	143

CONCLUSION.....	146
REFERENCES	147

ANNEX A

ANNEX B

ANNEX C

ANNEX D

LIST OF TABLES

Table 1: Storey Mass of Building 1-----	28
Table 2: Storey Mass of Building 2-----	29
Table 3: Storey Shear Calculation for Building 1 -----	29
Table 4: Storey Shear Calculation for Building 2 -----	30
Table 5: Soft Storey Check for Building 1 -----	45
Table 6: Soft Storey Check for Building 2 -----	46
Table 7: Eccentricity Check for Building 1-----	46
Table 8: Eccentricity Check for Building 2-----	47
Table 9: Calculation of Design Eccentricity of Building 1 in X direction -----	47
Table 10: Calculation of Design Eccentricity of Building 1 in Y direction-----	48
Table 11: Calculation of Design Eccentricity of Building 2 in X direction-----	48
Table 12: Calculation of Design Eccentricity of Building 2 in Y direction-----	49
Table 13: Storey Drift Check for Building 1 -----	50
Table 14: Storey Drift Check for Building 2 -----	50
Table 15: Torsional Irregularity Check for Building 1 in X-direction-----	51
Table 16: Torsional Irregularity Check for Building 1 in Y-direction-----	51
Table 17: Torsional Irregularity Check for Building 2 in X-direction-----	52
Table 18: Torsional Irregularity Check for Building 2 in Y-direction-----	52
Table 19: Modal Analysis Results for Building 1 -----	52
Table 20: Modal Analysis Results for Building 2 -----	53
Table 21: Summary of Flexural Design of Beam-----	71
Table 22: Summary of Required Reinforcement of Beam -----	72
Table 23: Summary of Provided Reinforcement for Beam -----	72
Table 24: General Information of Beam B2-C2 -----	76
Table 25: Reinforcement Requirement for Beam B2-C2-----	77
Table 26: Provided Reinforcement for Beam B2-C2 -----	77
Table 27: General Information of Beam C2-D2 -----	78
Table 28: Required Reinforcement for Beam C2-D2 -----	79
Table 29: Provided Reinforcement for Beam C2-D2 -----	79
Table 30: Sway Force Calculation for Beam C2-D2-----	80
Table 31: General Information of Beam A2-B2 -----	81

Table 32: Required Reinforcement for Beam A2-B2 -----	81
Table 33: Provided Reinforcement for Beam A2-B2 -----	82
Table 34: Shear Force From Sway Condition for Beam A2-B2-----	82
Table 35: General Information of Beam B2-C2 -----	83
Table 36: Reinforcement Required for Beam B2-C2 -----	84
Table 37: Provided Reinforcement for Beam B2-C2 -----	84
Table 38: Shear Force From Sway Condition for Beam B2-C2-----	85
Table 39: General Information of Beam C2-D2 -----	86
Table 40: Required Reinforcement for Beam C2-D2 -----	86
Table 41: Shear Force From Sway Condition for Beam C2-D2-----	87
Table 42: General Information of Beam D2-E2 -----	88
Table 43: Required Reinforcement For Beam D2-E2-----	89
Table 44: Provided Reinforcement for Beam D2-E2 -----	89
Table 45: Shear Force Calculation for Beam D2-E2-----	90
Table 46: Design of Column for Building 1-----	91
Table 47: Calculation of Shear Force in Column in Building 1 -----	98
Table 48: Design of Column of Building 2-----	99
Table 49: Calculation of Shear Force in Column of Building 2 -----	106
Table 50: Design Of Staircase of Building 1 -----	108
Table 51: Design of Staircase of Building 2-----	112
Table 52: Lateral Force Calculation for Lift Core Design-----	123
Table 53: Design Stress for Building 1-----	129
Table 54: Moment Calculation for Foundation Design of Building 1 in X-direction -----	130
Table 55: Moment Calculation for Foundation Design of Building 1 in Y-direction -----	130
Table 56: Design Stress Calculation for Building 2-----	137
Table 57: Moment Calculation for Foundation Design of Building 2 in X-direction -----	138
Table 58: Moment Calculation for Foundation Design of Building 2 in Y-direction -----	138

LIST OF FIGURES

Figure 1: Stress-Strain Curve for Concrete and Stress Block Parameters-----	22
Figure 2: Load Distribution Pattern in Two-way Slab-----	31
Figure 3: Influence Area for Column Design -----	38
Figure 4: Influence Area for Column Design -----	40
Figure 5: Rendered ETABS Model of Building 1 -----	42
Figure 6: Rendered ETABS Model of Building 2 -----	42
Figure 7: Axial Force Diagram of Building 2	
Figure 8: Axial Force Diagram of Building 1 -----	43
Figure 9: Shear Force Diagram in Building	
Figure 10: Shear Force Diagram of Building 1 -----	43
Figure 11: Bending Moment Diagram of Building 2	
Figure 12: Bending Moment Diagram of Building 1 -----	44
Figure 13: Design Strip for Slab -----	57
Figure 14: L, Rectangular and T Beam -----	67
Figure 15: Typical Staircase -----	107
Figure 16: Design of Basement Wall-----	116
Figure 17: Lift Core-----	121
Figure 18: Types of Columns Used in Foundation -----	131
Figure 19: Ramp Dimensions-----	143

NOTATIONS

A_g	Gross Area of Concrete
A_h	Horizontal Seismic Coefficient
A_{sc}	Area of Steel in Compression
A_{st}	Area of Steel in Tension
$A_{st,req}$	Area of Steel Required
A_h	Horizontal Seismic Coefficient
b_s	Support Width
B	Width
D	Effective Depth
d'	Effective Cover
D	Overall Depth
E	Modulus of Elasticity
f_{ck}	Characteristics Strength of Concrete
F_y	Characteristics Strength of Steel
f_s	Steel Stress of Service Load
H	Height of Building
I	Importance Factor (For Base Shear Calculation)
I_x, I_y	Moment of Inertia about X and Y-axis respectively
K	Structural Performance Factor
K_x	Stiffness in X-direction
K_y	Stiffness in Y-direction
L	Length of Member
L_x, L_y	Clear span of slab along shorter and longer direction respectively
l_x, l_y	Effective span of slab along shorter and longer direction respectively

L_d	Development Length of bar
M	Bending Moment
M_u	Factored Moment
$M_{u,max}$	Maximum Bending Moment
P_u	Factored Axial Load
P_t	Percentage of Tensile Reinforcement
P_c	Percentage of Compressive Reinforcement
Q	Design Lateral Force
R	Response Reduction Factor
S_a/g	Average Response Acceleration Coefficient
S_v	Spacing
T_a	Fundamental Natural Period of Vibrations
V_b	Design Seismic Base Shear
V_u	Factored Shear Force
W	Seismic Weight of Floor
W_u	Design Load
X_u	Actual Depth of Neutral Axis
Z	Zone Factor
τ_c	Allowable Shear Stress
τ_v	Nominal Shear Stress
Φ	Diameter of Bar

ABBREVIATIONS

DL	Dead Load
EQ _x	Earthquake Load in X- direction
EQ _y	Earthquake Load in Y- direction
LL	Live Load
IS	Indian Standard
RCC	Reinforced Cement Concrete
Cl	Clause

1. INTRODUCTION

1.1 Background

The rapid growth of urbanization in recent decades has spurred the development of multistory structures around the world, particularly in emerging economies. The shortage of land in highly populated areas of the world is a major economic motivation for the rise of tall (especially residential) buildings. The race to create the highest buildings in a city, country, region, or world has fueled the growth of tall buildings all around the world.

In recent decades, the competition to build the tallest buildings has been expanded to include the competition to build the most iconic and aesthetically outstanding structures, which are generally characterized by complex geometrics and leaning/twisting forms. Earthquakes, as one of the most devastating natural disasters, have prompted further consideration in the design of these structures.

The design of the structure has been given special consideration as a result of the earthquake. With a magnitude of 7.8Mw and a maximum Mercalli Intensity of VIII, it struck around 11:56 Nepal Standard Time on April 25, 2015 (severe). The entire damage was estimated to exceed \$5 billion, with 8,959 people killed and 23,447 injured. Its epicenter was in Gorkha's Barpak. It is the deadliest natural disaster to strike Nepal since the earthquake that struck Nepal and Bihar in 1934. Hundreds of thousands of people were displaced, and entire communities were leveled in several parts of the country. At UNESCO World Heritage sites in the Kathmandu Valley, centuries-old structures were demolished. Nepal is located on the southern end of the diffuse collision boundary, which occurs when the Indian Plate pushes into the Eurasian Plate. In central Nepal, the plates are convergent at a rate of around 45 mm (1.8 in) every year.

For the seismic design and analysis of multistory buildings, it is important to consider the earthquake effect (seismic effect), unique loading patterns, and subsurface bearing capacity.

Given that our country is located in an active tectonic zone where the Indian plate is thrusting against the Eurasian plate, multistory structure design that ignores seismic forces is unavoidable. For the seismic design and analysis of multistory buildings, it is important to examine the seismic effect, loading pattern, soil bearing capability, and other factors. In response to this, we recommend completing a project on **“Earthquake Resistant Analysis and Design of Multipurpose Building”**

1.2 Title and Theme of Project

The project's title is “**Earthquake Resistant Analysis and Design of Multipurpose Building.**”

The major goal of the project work under this title is to gain knowledge and skills with a focus on application. Aside from the use of analytical methodologies and design approaches, another goal of the project work is to expose and use various accessible codes of practice.

1.3 Objectives

The specific objectives of the project work are:

- Identification of structural arrangement in building plan
- Sectional design of structural components.
- Structural detailing of members.

Scopes of Project Work are

- Identification of the building and the requirement of the space.
- Determination of the structural system of the building to undertake the vertical and horizontal loads.
- Estimation of loads including those due to earthquakes.
- Preliminary design for the geometry of structural elements.
- Determination of fundamental time period by free vibration analysis.
- Calculation of base shear and vertical distribution of equivalent earthquake load.
- Identification of load cases and load combination cases.
- Finite element modelling of the building and input analysis.
- The structural analysis of the building by ETABS 19 for different cases of loads.
- Review of analysis outputs for the design of individual components.
- Design of RC frame members (slabs, beams, and columns), walls, isolated and combined foundation, staircase, and others by limit state method of design
- Detailing of individual members and preparation of drawings as a part of a working construction document.

1.4 Salient Features

1) Name of the Project: Earthquake Resistant Analysis and Design of Multistory Multipurpose Building

2) Location:

- a) Province: Lumbini
- b) District: Gulmi
- 3) Type of Building: Multipurpose Building
- 4) Structural System: Special Moment Resisting Frame
- 5) Soil Type: II
- 6) Seismic zone: V
- 7) No of Story:
 - Building 1: 2 Basements + 7 floors
 - Building 1: Basement + 7 floors + Staircase Cover
- 8) Dimension of building:
 - a) Length: Building 1 – 19.5 m Building 2 – 20.2m
 - b) Maximum Breadth: 21.5 m
 - 9) Type of Staircase: Dog-legged
- 10) Type of foundation: Raft Foundation
- 11) Floor Height:
 - a) Basement: 3.6 m
 - b) Typical: 3.6 m
 - c) Staircase cover: 3.6 m
- 12) Infill wall: Brick Masonry
 - a) Main wall: 0.230 m
 - b) Partition wall: 0.110 m
- 13) Design criteria: As per IS code
- 14) Size of structural elements:
 - a) Beam: 650*350 mm, 350*250mm
 - b) Column: 650*650 mm
 - c) Slab thickness: 150 mm
 - d) Depth of footing: 0.925 m
- 15) No of columns:
 - a) Basement: 45
 - b) Typical: 45
 - c) Staircase cover: 4
- 16) Number of lifts available: 1

Codes followed

The following codes were used for structural analysis and design:

- Indian Standard, Code of Practice for Plain and Reinforced Concrete IS 456:2000.
- Design Aids for Reinforced Concrete to IS 456:2000, SP-16.
- Criteria for Earthquake Resistant Design of Structures IS 1893:2016.
- Ductile Design and Detailing of Reinforced Concrete Structures Subjected to Seismic forces Code of Practice IS 13920:2016.
- Code of practice for Design loads IS 875 part-I (Dead load).
- Code of practice for Design loads IS 875 part- II (Imposed load).

1.4.1 Methods of Analysis

ETABS 19 is adopted as the basic tool for the analysis of the structure and this program is based on the finite element method. The stresses and displacement of various structural elements of the building are obtained using this program which is used for the design of the structural members. Lift walls, Foundation, Slab, and Staircase are analyzed separately. IS 1893-2016 (part 1) is followed for the seismic analysis of the building. The fundamental time period of the structure is calculated as specified in the code.

1.4.2 Design

Limit state method is used for the design of RC elements.

The following materials are adopted for the design of elements:

- Grade of concrete M30 for Beam, Slab, Column & Foundation.
- Grade of reinforced steel Fe500 for longitudinal as well as lateral bar.

1.5 Limitations of the Project

Due to various constrictions prevailing in the course of the project work, the study is limited in the following aspects:

- Early feasibility of the project is assumed to be done.
- Building is modified architecturally.

- Data manipulation is checked manually with underlying concepts but some similar sections are relied solely on software due to time limitations.
- In-plane stiffness of the wall is not considered.

2. ASPECTS OF SEISMIC PERFORMANCE AND BUILDING DESCRIPTION

Nepal has witnessed several major disasters due to earthquakes in the current decade. Earthquakes do not kill people but poorly designed or constructed buildings do. These earthquakes have clearly brought out that we need to have a comprehensive strategy for disaster mitigation which should include planning, design and construction of earthquake resistant buildings through strict compliance of codal provisions for earthquake countermeasures.

The general philosophy of earthquake-resistant building design is that:

- Under minor but frequent shaking, the main members of the building that carry vertical and horizontal forces should not be damaged; however, building parts that do not carry load may sustain repairable damage.
- Under moderate but occasional shaking, the main members may sustain repairable damage while the other parts of the building may be damaged such that they may even have to be replaced after the earthquake.
- Under strong but rare shaking, the main members may sustain severe (even irreparable) damage, but the building should not collapse.

2.1 Seismic Performance of Building

In recent earthquakes, concrete structures have been severely damaged or collapsed, which has raised questions about the seismic adequacy of existing buildings. The behavior or level of performance of a building during earthquakes depends critically on its overall shape, size, and geometry. Generally, it is common that an architect fixes the configuration i.e. shape, size, and geometry of a building and the structural engineer adds the structural design. The conventional approach to the earthquake-resistant design of buildings depends upon providing the building with strength, stiffness, and inelastic deformation capacity which are great enough to withstand a given level of earthquake-generated force. This is generally accomplished through the selection of an appropriate building configuration and the careful detailing of structural members.

2.2 Structural Layout

When creating a frame building, structural member in regard to their stiffness are to be uniformly distributed and these should be well framed up in both orthogonal directions with nearly uniform spans. It is always advisable to provide stiffer elements such as walls or bracings

along the perimeter of the building rather than concentrating them in the centre of the building, whatever be the structural system. It results in enhanced torsional resistance of the building giving it additional earthquake protection. It helps to maintain similar stiffness in both directions. An additional force viz. torsion emerges when the Centre of Gravity does not coincide the Centre of Stiffness.

2.3 General Principles for the Design

On starting at the overview of structural action, mechanism of damage and modes of failure of buildings, we can come up with following considerations: -

- Structures should not be brittle or collapse suddenly. Rather, they should be tough, able to deflect or deform a considerable amount.
- Resisting elements, such as bracing or shear walls, must be provided evenly throughout the building, in both directions side-to-side, as well as top to bottom.
- All elements, such as walls and the roof, should be tied together so as to act as an integrated unit during earthquake shaking, transferring forces across connections and preventing separation.
- The building must be well connected to a good foundation and the earth.
- Wet, soft soils should be avoided, and the foundation must be well tied together, as well as tied to the wall. Where soft soils cannot be avoided, special strengthening must be provided.
- Care must be taken that all materials used are of good quality, and are protected from rain, sun, insects and other weakening actions, so that their strength lasts.
- Unreinforced earth and masonry have no reliable strength in tension, and are brittle in compression. Generally, they must be suitably reinforced by steel or wood. Adherence to above mentioned simple rules, a designer can give a structure that does not prevent all damage in moderate or large earthquakes, but life-threatening collapses can be prevented, and damage limited to repairable proportions. These principles fall into several broad categories, some of which are listed as under: -
 - i. Planning and layout of the building involving consideration of the location of rooms and walls, openings such as doors and windows, the number of stories, etc. At this stage, site and foundation aspects should also be considered.
 - ii. Layout and general design of the structural framing system with special attention to furnishing lateral resistance.
 - iii. Consideration of highly loaded and critical sections with provision of reinforcement as required.

2.4 Terminology

Response reduction factor:

The response reduction factor assigned to different types of structural systems reflects design and construction experience, as well as evaluation of performance of structure in major and moderate earthquakes. It endeavors to account for the energy absorption capacity of the structural system by damping (which is normally taken as 5% of critical damping for RCC structures) and inelastic action through several load reversals.

R values reflect the degree of continuity and ductility provided for structural systems. A building with a value of R equal to 1.0 corresponds to a structural system exhibiting little or no ductility and value greater than 1.0 is presumed to be capable of undergoing inelastic cyclic deformation.

The value of R is taken as 5 for RCC moment resisting frame specially designed to provide ductile behaviour and comply with requirements given in IS:13920:2016.

Number of modes:

The number of modes to be considered in the response spectrum analysis should be such that at least 90% of the seismic mass of the structure gets excited in each of the principal horizontal directions.

Closely spaced modes:

Closely spaced modes of structure are those of its natural modes of vibration whose natural frequencies differ from each other by 10 percent or less of the lower frequency i.e.

$$(\omega_j - \omega_i) / \omega_i \leq 0.1 \quad \text{where,}$$

ω_j = any frequency of mode

ω_i = lower frequency of the mode.

Modes failing to fulfill the above criteria are widely spaced modes.

Storey drift:

The relative inter-storey horizontal displacement is referred to as storey drift. A limitation on storey drift is necessary to avoid discomfort to occupants of the building and to save non-structural elements from damage. A drift limitation of 0.004 times or (0.4%) the storey height in the elastic range is imposed by IS 1893(part 1):2016.

Regularity:

The regularity of a building can significantly affect its performance during a strong earthquake. Past earthquakes have repeatedly shown that buildings having irregular configurations suffer greater damage than buildings having regular configuration.

Regular structure have no significant physical discontinuities in plan, vertical configuration or in their lateral force resisting system whereas, irregular structure have significant physical discontinuities in configuration or in their lateral force resisting system. They may have; either plan irregularity or vertical irregularity or mass irregularity.

Dynamic analysis shall be performed in accordance to IS 1893(part 1):2016, clause 7.7.

3. DESIGN METHODS

3.1 Understanding and Design Philosophy

The satisfactory performance of the building against all possible worst conditions is the main aim of analyzing and designing the building. So that the buildings fulfill the functions for which they have been built during their intended life. In this project, limit state method of design is used for designing the structural elements. And the structural design of reinforced cement concrete is the main concern.

3.2 Design Philosophies

Basically, there are four design philosophies for RCC structure.

- I. Working stress design
- II. Ultimate load design
- III. Limit state design
- IV. Performance based design

Limit State Design: Limit state design is originally based on ultimate or plastic design. This method is the probabilistic approach. Limit state is a particular condition at which a structure becomes unfit for its intended purpose. It may be also defined as the acceptable limits for the safety and serviceability requirements of the structure before failure occurs. The object of design is to achieve an acceptable probability the structure will not become unserviceable in its life time. The structure is designed to withstand safely all loads liable to act on it; it shall also satisfy the serviceability requirement, such as limitation on deflection, cracking and vibration. This method accommodates both variation in material strength and the variation in loading. Two types of limit states must be examined in design and are given below:

Assumptions for the limit state of collapse in flexure:

- a. The plane section normal to the axis of member remains plane after bending.
- b. The maximum strain in concrete at the outermost compression fiber is 0.0035.

- c. The relationship between the compressive stress distribution in concrete and the strain in the concrete may be assumed to be rectangle, trapezoid, parabola or any other shape. For design purpose, the compressive strength of concrete in the structure shall be assumed to be 0.67 times the characteristic strength. The partial safety factor $\gamma_m = 1.5$ shall be applied.
- d. The tensile strength of concrete is ignored.
- e. The stresses in the reinforcement are derived from the representative stress-strain curve for the type of steel used. For design purpose the partial safety factor $\gamma_m = 1.15$ shall be applied.
- f. The maximum strain in the tension reinforcement in the section at failure shall not be less than:
 $\frac{f_y}{1.15E_s} + 0.02$

where, f_y = characteristics strength of steel. E_s = modulus of elasticity of steel.

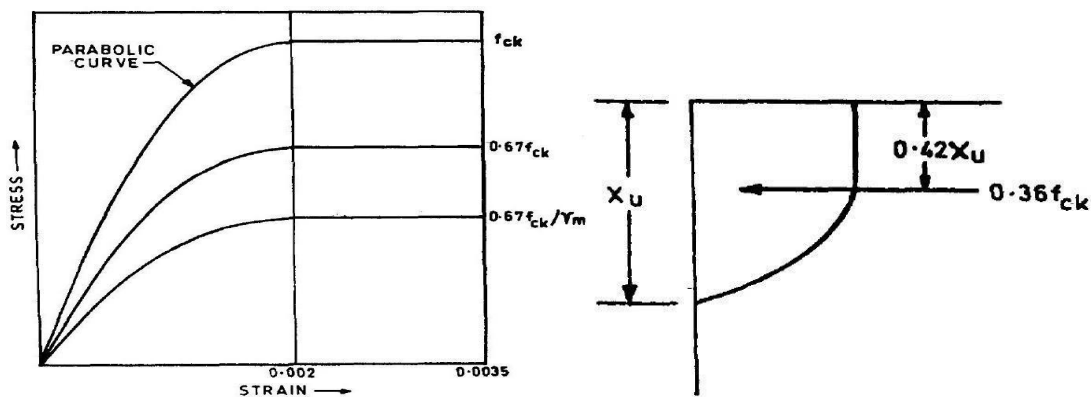

Figure 1: Stress-Strain Curve for Concrete and Stress Block Parameters

Assumptions for the limit state of collapse in compression:

In addition to the assumptions for limit state of collapse in flexure from (a) to (f), the following shall be assumed:

- a. The maximum compressive strain in concrete in axial compression is taken as 0.002.
- b. The maximum compressive strain at the highly compressed extreme fiber in concrete subjected to axial compression and bending and when there is no tension on the section shall be 0.0035 minus 0.75 times the strain at least compressed extreme fiber.

The most important of these limit states which must be examined in design are as follows:

Limit state of collapse

This state corresponds to the maximum load carrying capacity. Violation of collapse limit state implies failure in sense that a clearly defined limit state of structural usefulness has been exceeded. However, it does not mean a complete collapse. This limit state may correspond to:

- a. Flexure
- b. Compression
- c. Shear
- d. Torsion

Limit state of serviceability

This state corresponds to development of the excessive deformation and is used for checking members in which magnitude of deformation may limit the use of the structure or its components. This state may correspond to:

- a. Deflection
- b. Cracking
- c. Vibration.

a. Control of deflection

The deflection of a structure shall not adversely affect the appearance or efficiency of the structure or finishes or partitions. Two methods are given in code for checking the deflections. These are:

- Limiting the span/effective depth ratio given in clause 23.2, IS: 456-2000 which should be used in all normal cases, and
- Calculation of deflection given in Appendix C of code to be followed in special cases.

b. Control of cracking

Cracking is a very complex phenomenon. Design considerations for crack control would require the following:

- Expression for crack width and spacing, and (Annex F of IS 456:2000).
- Allowable crack widths under different service conditions with due considerations to corrosion and durability of concrete (Clause 35.3.2 of IS 456:2000).
- Unless the calculation of crack widths shows that a greater spacing is acceptable for the flexural members in normal internal or external conditions of exposure, the maximum distance between bars in tension shall not exceed the value as given in IS 456:2000, Clause 26.3.3.

- Cracks due to bending in compression member subjected to design axial load $>0.2f_{ck} \times A_c$, need not be checked. For flexural members (A member which is subjected to design load $<0.2f_{ck} \times A_c$) if greater spacing of reinforcements as given in Clause 26.3.2, IS 456:2000 is required, the expected crack width should be checked by formula given in Annex F of IS 456:2000.

c. Control of Vibration

A dynamic load is any load of which the magnitude, direction or position varies with the time and almost any RCC structural system may be subjected to one form or another loading during its life-time. Similarly structural response i.e. resulting stresses or deflections is also time-varying or dynamic and is expressed in terms of displacements. The limit state concept of design of reinforced concrete structures takes into account the probabilistically and structural variation in the material properties, loads and safety factors.

d. Loads

Basic objective of constructing building or any structure is to support loads. There are different types of loads, which come across and have to be dealt during analysis and design of any structure.

3.3.1 Design loads

The buildings and structures are subjected to a number of loads, forces and effects during their service life. The following loads usually determine the size of structural element:

- a. Dead load (DL)
- b. Imposed load (IL)
- c. Wind load (WL)
- d. Earthquake load (EL)

Beside above-mentioned loads, the effect of other forms of load such as fatigue, construction loads, accidental loads, impact and collision, explosions, fire, etc. should also be considered in design of structure.

Loading Pattern

Dead loads are computed from the dimensions of the structural member such as walls, beams, slabs, etc. and their material densities conforming to IS 875 (Part I). The uniformly distributed dead and live load acting on the slab are transferred to the beams holding the slab. The slab load is distributed on the floor beams as shown in figure below. The smaller beam holds the

triangular load and the longer beams hold the trapezoidal load as shown in figure. The beam element also resists the self-weight and the wall load including all the finish loads on wall. The load from beam is transferred to the column which in turn transfers all the load to the foundation.

Lateral load is transferred through the diaphragms. The diaphragms take lateral forces from the storey at or above their level and transfers them to the frames in the storey immediately below. Shear walls receive lateral forces from diaphragms and transmit them to the foundations.

Load Combinations

Various load cases and combinations are considered in order to obtain the critical loading in the structure. The load combinations taken are as follows:

- $1.2 (DL + IL \pm (EL_X \pm 0.3EL_Y \pm 0.3EL_Z))$
- $1.2 (DL + IL \pm (EL_Y \pm 0.3EL_X \pm 0.3EL_Z))$
- $(DL \pm (EL_X \pm 0.3EL_Y \pm 0.3EL_Z))$
- $(DL \pm (EL_Y \pm 0.3EL_X \pm 0.3EL_Z))$
- $0.9 DL \pm 1.5 (EL_X \pm 0.3EL_Y \pm 0.3EL_Z)$
- $0.9 DL \pm 1.5 (EL_Y \pm 0.3EL_X \pm 0.3EL_Z)$
- $1.2 (DL + IL + (RS_X + 0.3RS_Y + 0.3RS_Z))$
- $1.2 (DL + IL + (RS_Y + 0.3RS_X + 0.3RS_Z))$
- $1.5 (DL + (RS_X + 0.3RS_Y + 0.3RS_Z))$
- $1.5 (DL + (RS_Y + 0.3RS_X + 0.3EL_Z))$
- $0.9 DL + 1.5 (RS_X + 0.3RS_Y + 0.3RS_Z)$
- $0.9 DL + 1.5 (RS_Y + 0.3RS_X + 0.3RS_Z)$

3.3.2 Load assessment

The proposed building is a RCC framed structure, located in Kathmandu. Thus wind loads, snow loads, and other special types of loads, as described by IS 875(part 5):1987 can be taken as negligible as compared to the dead, live and seismic loads.

a. **Dead Loads:** According to the IS 875(Part 1):1987, the dead load in a building shall comprise the weights of all walls, partitions, beam, column, floors and roofs and shall include the weights of all other permanent features in the building.

b. **Live Loads:** It means the load assumed or known resulting from the occupancy or use of a building and includes the load on balustrades and loads from movable goods, machinery and plant that are not an integral part of the building. These are to be chosen from IS 875(Part

2):1987 for various occupancies where required. The code permits certain modifications in the load intensities where large contributory areas are involved, or when the building consists of many stories.

c. **Eccentricity of vertical loads:** When transferring the loads from parapets, partition walls, cladding walls and facade walls, etc. to the supporting beams or columns, the eccentricity with these loads should be properly considered in the case of rigid frames of reinforce concrete. Such eccentricities will produce externally-applied joint moments similar to these arising from projecting cantilevers and these should be included in frame design.

d. **Seismic Loads:** These are the loads resulting from the vibration of the ground underneath the super-structure during an earthquake. Earthquake is an unpredictable natural phenomenon. Nobody knows the exact timing and magnitude of such loads. Seismic loads are to be determined essentially to produce an earthquake resistant design.

Since the probable maximum earthquake occurrence is not frequent, designing building for such earthquake isn't practical as well as economically prudent. Instead, reliance is placed on kinetic dissipation in the structure through plastic deformation of elements and joints and the design forces are reduced accordingly. Thus, the philosophy of seismic design is to obtain a no-collapse structure rather than no-damage structure.

Estimation of Loads

It is one of the most important steps in structural design. Proper recording of them is required for confusion free analysis.

Dead loads:

- a. Calculate the weight of those elements of building whose dimensions are fixed already from functional considerations and can be worked out carefully. These are generally non-structural elements and of parapets, rooftops, railings, etc.
- b. From pre-design, calculate weight of structural elements such as beam, column, slab etc.
- c. Put all loads systematically on sketches, say plan wise, showing their gravity lines with reference to column center-lines.

S.N.	Material Used	Unit Weight	Type of Member
1	Cement Concrete for RCC	25 KN/m ³	Beam, Column, Slab
2	Finishing	1 KN/m ³	All flooring spaces

3	Brick Masonry	19 KN/m ³	Walls
---	---------------	----------------------	-------

Live loads:

The details of imposed loads acting on the floors and roof of the building are also evaluated from the type of building (Commercial) and type of occupancy from IS 875 Part 2.

Seismic or earthquake loads:

Earthquake or seismic load on a building depends upon its geographical location, lateral stiffness and mass, and is reversible.

IS 1893:2016 was followed for the calculation of the earthquake loads, which specifies two methods:

Seismic coefficient method

Response spectrum method

3.4.1 Lateral Load Assessment

3.4.1.1 Base Shear Calculation

According to IS 1893 (Part 1): 2016 Cl. No. 6.4.2 the design horizontal seismic coefficient A_h for a structure shall be determined by the following expression:

$$A_h = \frac{ZIS_a}{2Rg}$$

Where,

Z = zone factor given by IS 1893 (Part 1):2016 Table 2, for zone V, $Z = 0.36$

I = Importance factor, 1.2

R = Response reduction factor given by IS 1893 (Part 1): 2016 Table 7, $R = 5$ for SMRF

S_a/g = Average response acceleration coefficient which depends on the fundamental natural period of vibration (T_a)

According to IS 1893 (Part 1):2016 Clause 7.4.2

$$T_a = 0.075 h^{0.75} \text{ seconds}$$

Where h is the height of the building above ground level in m.

For Building 1:

$$h = 28.8 \text{ m}$$

$$T_a = 0.075 * 28.8^{0.75} = 0.932$$

$$S_a/g = 1.36 / T = 1.459$$

$$A_h = 0.063$$

For Building 2:

$$h = 25.2 \text{ m}$$

$$T_a = 0.075 * 25.2^{0.75} = 0.843$$

$$S_a/g = 1.36/ T = 1.61$$

$$A_h = 0.0696$$

According to IS 1893 (Part 1: 2016) Cl. 7.5.3, the total design lateral force of the design seismic base shear (V_B) along any principal direction is given by:

$$V_B = A_h * W$$

Where W = seismic weight of the building

$$\text{Base shear of building 1} = A_h * W = 0.063 * 41742.97 = 2629 \text{ KN}$$

$$\text{Base shear of building 2} = A_h * W = 0.0696 * 39682.09 = 2761.87 \text{ KN}$$

According to IS 1893 (Part 1: 2016) Cl. 7.7.1, the design base shear computed as above shall be distributed along the height of the building as per the following expression:

$$Q_i = V_b \frac{W_i h_i^2}{\sum_{i=1}^n W_i h_i^2}$$

Where,

Q_i = Design lateral force at floor i

W_i = Seismic weight at floor i

H_i = height of floor I measured from base

N = no. of stories in the building

Calculation of Seismic Weight

Building 1

Table 1: Storey Mass of Building 1

Table : Storey mass summary		
Floor	Ux	Uy
Top	387894.14	387894.14
Sixth	572414.53	572414.53
Fifth	544975.07	544975.07
Fourth	497830.74	497830.74
Third	566073.03	566073.03
Second	569895.06	569895.06
First	551633.28	551633.28
Ground	564428.71	564428.71
Total	4255144.56	

Total seismic weight (W) = 4255144.56 kg

$$= 41742.96 \text{ KN}$$

Building 2

Table 2: Storey Mass of Building 2

Table: Storey mass summary		
Floor	U _x	U _y
STAIR COVER	69019.14	69019.14
TOP	422217.3	422217.3
6th	514057.09	514057.09
5th	563753.64	563753.64
4th	503362.51	503362.51
3rd	564963.1	564963.1
2nd	553034.72	553034.72
1st	567425.21	567425.21

Total seismic weight(W) = 4045065.24 kg

$$= 39682.09 \text{ KN}$$

3.4.1.2 Story Shear Calculation

Building 1:

Table 3: Storey Shear Calculation for Building 1

Floor	Height	Seismic weight	W _i *h _i ² (1)	1/sum(1)	Design lateral load at each storey	Storey shear
Top	28.8	3805.242	3156219.521	0.244	640.514	640.513628
Sixth	25.2	5615.387	3565995.068	0.275	723.672	1364.18586
Fifth	21.6	5346.205	2494325.609	0.193	506.191	1870.37675
Fourth	18	4883.720	1582325.137	0.122	321.112	2191.48902
Third	14.4	5553.176	1151506.663	0.089	233.683	2425.17229
Second	10.8	5590.671	652095.812	0.050	132.334	2557.50664
First	7.2	5411.522	280533.325	0.022	56.931	2614.43722
Ground	3.6	5537.046	71760.112	0.006	14.563	2629
Total			12954761.25	1		

Building 2:

Table 4: Storey Shear Calculation for Building 2

Floor	Height	Seismic weight	$W_i \cdot h_i^2(1)$	$1/\sum(1)$	Design lateral load at each storey			Storey shear
STAIR COVER	28.8	677.078	561595.38	0.0599972	165.7			165.7046
TOP	25.2	4141.952	2630305.02	0.2810049	776.1			941.8035
6th	21.6	5042.900	2352815.45	0.2513597	694.2			1636.026
5th	18	5530.423	1791857.12	0.1914305	528.7			2164.732
4th	14.4	4937.986	1023940.82	0.1093913	302.1			2466.857
3rd	10.8	5542.288	646452.474	0.0690628	190.7			2657.599
2nd	7.2	5425.271	281246.028	0.0300465	83.0			2740.584
1st	3.6	5566.441	72141.0794	0.0077071	21.3			2761.87
Total			9360353.37	1				

4. PRELIMINARY DESIGN

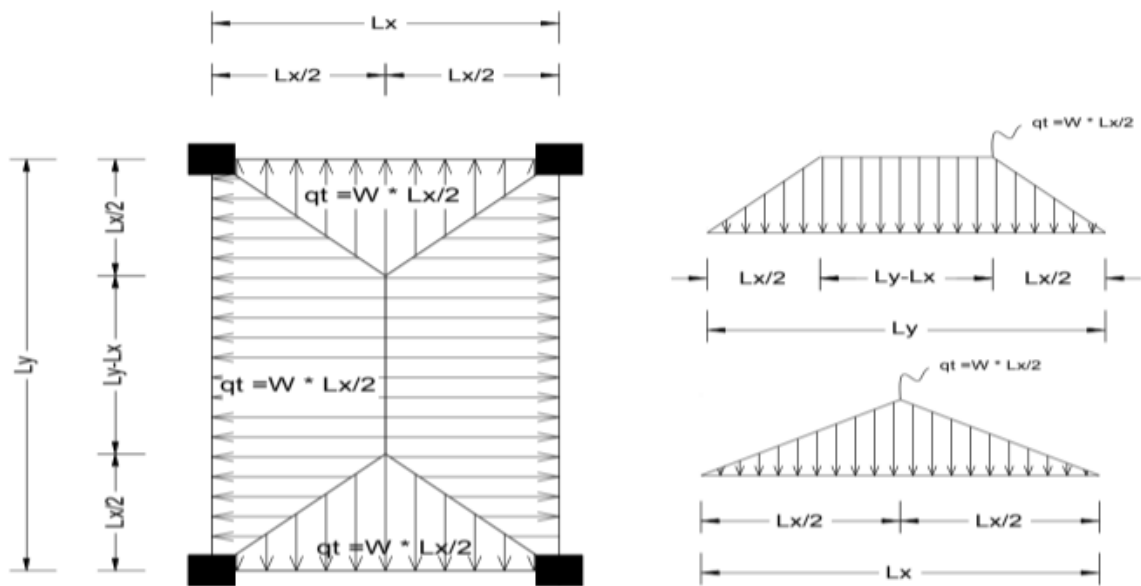

Figure 2: Load Distribution Pattern in Two-way Slab

Preliminary design of structural members is carried out in order to estimate the approximate size of the members. The design is done with limited information regarding imposed loads, dimensions, etc. Preliminary design is essential for initial cost estimations, comparison between different alternatives, initial estimate for computer-based analysis and also for checking the results of detailed design.

4.1 Preliminary Design of Slab

Preliminary sizing of the slabs is worked out as per the limit state of serviceability (deflection) consideration by conforming to IS456:2000 Clause: 23.2.1.

Preliminary design of slab

For the design of slab: DE45

The project building has the largest span of 6000mm X 6000mm.

$$l_x = 6000 \text{ mm}$$

$$l_y = 6000 \text{ mm}$$

$$(l_y/l_x) = (6000/6000)$$

$$= 1$$

Hence the slab is two-way continuous slab.

From IS 456:2000 Clause 23.2

Control of Deflection, we can draw out the following methodical steps to get the thickness of slab. Here d represents the thickness of the slab

$$\frac{\text{span}(l)}{\text{effective depth}(d)} \leq \alpha\beta\gamma l d$$

Here, $l = l_x = 6000 \text{ mm}$

Assume $\alpha\beta\gamma l d = 35$

So,

$$\begin{aligned} d &\geq \frac{l_x}{\alpha\beta\gamma l d} \\ &\geq 6000/35 \\ &\geq 171.42 (>150) \end{aligned}$$

Since d came out to be greater than 150mm, we need to provide a secondary beam which cuts the longest side into two equal halves.

But other slabs are not as big as the aforementioned slab. So preliminary design of another slab is done.

For design of slab: CD34

$l_x = 4500 \text{ mm}$

$l_y = 5700 \text{ mm}$

$$\begin{aligned} (l_y/l_x) &= (5700/4500) \\ &= 1.27 \end{aligned}$$

Hence the slab is two-way continuous slab.

From IS 456:2000 Clause 23.2

Control of Deflection, we can draw out the following methodical steps to get the thickness of slab. Here d represents the thickness of the slab

$$\frac{\text{span}(l)}{\text{effective depth}(d)} \leq \alpha\beta\gamma l d$$

Here, $l = l_x = 4500 \text{ mm}$

Assume $\alpha\beta\gamma l d = 35$

So,

$$\begin{aligned} d &\geq \frac{l_x}{\alpha\beta\gamma l d} \\ &\geq 4500/35 \\ &\geq 128.57 \text{ mm} \end{aligned}$$

Assuming diameter of bars=10mm

Clear cover =15mm

We get,

$$D=d+\left(\frac{\phi}{2}\right)+15$$

$$=128.57+5+15$$

$$=148.57\text{mm}$$

So, the overall depth of slab is adopted as 150mm.

4.2 Preliminary Design of Beam

Preliminary sizing of the beam is worked out as per the limit state of serviceability (deflection) consideration by conforming to IS456:2000 Clause: 23.2.1 similar to that of slab element.

4.2.1 Preliminary design of Primary beam

For Building 1:

A. By Deflection Criteria

The methodical steps in designing the beam element preliminarily with respect to IS 456:2000, IS 1893, IS13920, IS 4326 are same as the slab element.

Hence, from Clause 23.2 Control of Deflection of IS 456:2000 we can draw out the following methodical steps to get the depth of beam.

$$\frac{\text{span}(l)}{\text{effective depth}(d)} \leq \alpha\beta\gamma l d$$

where,

$$\text{Span}(l)=6\text{m}=6000\text{mm}$$

$$\text{Assume } \alpha\beta\gamma l d=15$$

$$d \geq \frac{l}{\alpha\beta\gamma l d}$$

$$\geq 6000/15$$

$$\geq 400\text{mm}$$

A clear cover of 25mm for main bar of diameter 20 mm, we get the overall depth of beam as:

$$\text{Overall Depth of Beam (D)} = \text{Effective Depth} + 0.5 \times \text{Dia} + \text{Clear cover}$$

$$=d_{\text{eff}} + 0.5 \times \phi + \text{clear cover}$$

$$=400 + 0.5 \times 20 + 25 \text{ (}\phi \text{ is taken 20 mm)}$$

$$=435\text{mm}$$

B. By Moment Criteria Area of influence:

Division of load is done according to yield line theory:

Two portions of a slab are taken as shown in the figure below:

For the beam D4E4,

Influence area=17.405m²

Load calculations for critical beam

Dead Load Due to Slab:

DL =unit weight of concrete*influence area*depth of slab

$$=25\text{KN/m}^3 \times 17.405\text{m}^2 \times 0.150\text{m}$$

$$=65.26 \text{ KN}$$

Dead load of ceiling plaster 12.5mm thick=20.4 x 0.0125 x 17.405

$$=4.43 \text{ KN}$$

Self-weight of beam = 25*0.435*(0.435/1.5) *6

$$= 18.93 \text{ KN}$$

Total Dead Load=65.26 + 4.43 + 18.93 = 88.61 KN

Live Loads on Beam:

Live Load = LL = 4 KN/m² (Ref. 875 Part II)

Live Load on influence area = 4×17.405= 69.62 KN

Wall Loads on Beam:

External Wall Thickness = 230 mm

Wall Load =unit wt. x (floor ht. - depth of slab) x thickness x span

$$=20 \times (3.6-0.15) \times 0.23 \times 6 \times 0.85$$

$$= 80.93 \text{ KN}$$

(15% of load is reduced for openings)

So,

Total Load=88.610 + 69.62 + 80.93

$$=239.16 \text{ KN}$$

Factored load=1.5*239.16

$$=358.75 \text{ KN}$$

Load intensity = Factored load/span

$$=358.75/6$$

$$=59.79 \text{ KN/m}$$

Maximum bending moment = w²l²/10

$$= (59.79 \times 6 \times 6) / 10$$

$$= 215.25 \text{ KN-m}$$

Assuming balanced section

Take $d/b=1.5$

We have,

$$M(\max) = 0.133 \times f_{ck} \times b \times d^2 \quad (\text{For Fe500 steel})$$

$$189.604 = 0.133 \times 30 \times b \times 1.5b \times 1.5b$$

On solving,

We get $b=288.35\text{mm}$

Then,

$$d = 1.5 \times 288.35$$

$$= 432.53\text{mm}$$

Adopt $D=500\text{mm}$

$B=300\text{mm}$

The adopted values are subject to change depending upon the prevailing design conditions.

For Building 2:

A. By Deflection Criteria

$$\frac{\text{span}(l)}{\text{effective depth}(d)} \leq \alpha\beta\gamma l d$$

Where,

Span(l) = 6.5 m = 6500mm (C4D4)

Assume $\alpha\beta\gamma l d = 15$

$$d \geq \frac{l}{\alpha\beta\gamma l d}$$

$$\geq 6500 / 15$$

$$\geq 433.33 \text{ mm} = 450\text{mm}$$

A clear cover of 25mm for main bar of diameter 20 mm, we get the overall depth of beam as:

Overall Depth of Beam (D) = Effective Depth + 0.5*Dia + Clear cover

$$= d_{\text{eff}} + 0.5 \times \emptyset + \text{clear cover}$$

$$= 450 + 0.5 \times 20 + 25 \quad (\emptyset \text{ is taken } 20 \text{ mm})$$

$$= 485 \text{ mm}$$

B. By Moment Criteria Area of influence:

Division of load is done according to yield line theory:

$$\text{Influence area} = 20.625 \text{ m}^2$$

Load calculations for critical beam:

Dead Load Due to Slab:

DL = unit weight of concrete * influence area * depth of slab

$$= 25 \text{ KN/m}^3 \times 20.625 \text{ m}^2 \times 0.150 \text{ m}$$

$$= 77.34 \text{ KN}$$

Dead load of ceiling plaster 12.5mm thick = $20.4 \times 0.0125 \times 20.625$

$$= 5.26 \text{ KN}$$

Self-weight of beam = $25 \times 0.485 \times (0.485/1.5) \times 6.5$

$$= 25.48 \text{ KN}$$

Total Dead Load = $77.34 + 5.26 + 25.48 = 108.08 \text{ KN}$

Live Loads on Beam:

Live Load = LL = 4 KN/m^2 (Ref. 875 Part II)

Live Load on influence area = $4 \times 20.625 = 82.5 \text{ KN}$

Wall Loads on Beam:

External Wall Thickness = 230 mm

Wall Load = unit wt. x (floor ht. - depth of slab) x thickness x span

$$= 20 \times (3.6 - 0.15) \times 0.23 \times 6.5 \times 0.85$$

$$= 87.68 \text{ KN}$$

(15% of load is reduced for openings)

So,

Total Load = $108.08 + 82.5 + 87.68$

$$= 278.26 \text{ KN}$$

Factored load = 1.5×239.57

$$= 417.39 \text{ KN}$$

Load intensity = Factored load / span

$$= 417.39 / 6.5$$

$$= 64.21 \text{ KN/m}$$

Maximum bending moment = $wl^2/10$

$$= (64.21 \times 6.5^2) / 10$$

$$= 271.3 \text{ KN-m}$$

Assuming balanced section

Take $d/b=1.5$

We have,

$$M(\max)=0.133*f_{ck}*b*d^2 \quad (\text{For Fe500 steel})$$

$$271.3=0.133*30*b*1.5b*1.5b$$

On solving,

We get $b=311.5\text{mm}$

Then,

$$d = 1.5*311.5$$

$$= 467.25 \text{ mm}$$

Adopt $D=500\text{mm}$

$$B=300\text{mm}$$

4.2.2 Preliminary design of Secondary beam

Effective depth = 75% of depth of Primary beam

$$= 0.75 \times 500$$

$$= 375\text{mm}$$

Width = 75% of width of Primary beam

$$= 0.75 \times 300$$

$$= 225$$

Adopt depth=350mm and width=250mm

Section of secondary beam = 250mm × 350mm

4.3 Preliminary Design of Column

In the compression member i.e., columns, the cross section is worked out from the net vertical axial load on the column lying in the ground floor assuming suitable percentage of steel. The net vertical axial load on each column is worked out from the factored dead load and live load on the tributary area, which is taken as half of the slab areas adjacent to the column under consideration. The load is increased by 30% for the earthquake load to give the net vertical load.

Preliminary design of column

For Building 1:

Here, B3 column is considered critical for preliminary design.

Height of floor to ceiling = $3.6 - 0.15 = 3.45$ m

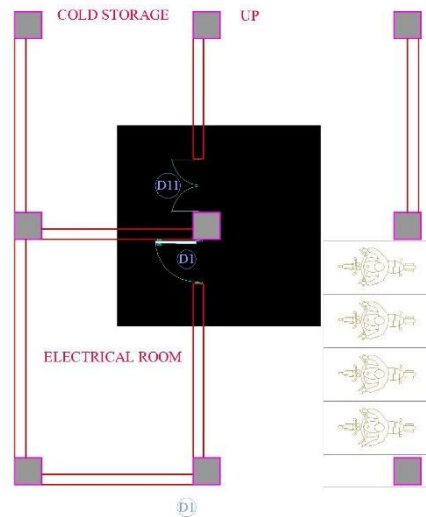

Figure 3: Influence Area for Column Design

Influence area for column = 21.25 m^2

Load Calculations:

DEAD LOAD

Dead Load (DL) = Area of the section x Specific weight x Depth of section

DL of slab (150 mm)

$$= 21.25 \times 0.15 \times 25 = 79.68 \text{ KN}$$

DL of ceiling plaster (12.5mm thick)

$$= 20.4 \times 0.0125 \times 21.25$$

$$= 5.418 \text{ KN}$$

DL of Beam

$$= 25 \times 0.3 \times (0.5 - 0.15) \times (4/2 + 4.5/2 + 4.5/2 + 5.5/2)$$

$$= 24.28 \text{ KN}$$

DL of floor finish (vitrified tile 10 mm thick)

$$= 24 \times 0.010 \times 21.25$$

$$= 5.1 \text{ KN}$$

DL of the partition wall

$$= 20 \times (3.6 - 0.5) \times [(4 + 4.5 + 4.5 + 5.5)/2] \times 0.23$$

$$= 131.905 \text{ KN}$$

Assuming deduction for opening as 15%

$$\begin{aligned}\text{Total wall load} &= 0.85 \times 131.905 \\ &= 112.12 \text{ KN}\end{aligned}$$

Total dead load on the one intermediate floor panel

$$\begin{aligned}&= 79.68 + 5.418 + 24.28 + 5.1 + 112.12 \\ &= 226.598 \text{ KN}\end{aligned}$$

$$\text{Self-weight of column} = 0.50 \times 0.50 \times (3.6-0.15) \times 25 = 21.5625 \text{ KN}$$

$$\text{Total dead load} = (226.598 + 21.5625) \times 8 \text{ KN} = 1985.284 \text{ KN}$$

$$\text{Live Load} = 4 \text{ KN/m}^2$$

$$\begin{aligned}\text{Live Load (LL)} &= 21.25 \text{ m}^2 \times 4 \\ &= 85 \text{ KN}\end{aligned}$$

Applying live load reduction factor in accordance to IS 875 – Part 2 [clause 3.2.1 page12]

$$\begin{aligned}\text{Total live load} &= (85 \times 8) \times (1-0.4) \\ &= 408 \text{ KN}\end{aligned}$$

$$\begin{aligned}\text{Total load on column} &= 1985.284 + 408 \\ &= 2393.284 \text{ KN}\end{aligned}$$

Providing partial safety factor of 1.5

$$\text{Total factored load} = 1.5 \times 2393.284 = 3589.926 \text{ KN}$$

From IS 456, page 71 clause [39.5]

Axial load on column (P_u) = $0.4 f_{ck} \times A_c + 0.67 f_y \times A_{sc}$ increasing P_u by 25% for earthquake resistance

Assuming 3% of cross- sectional area of column for reinforcement.

So,

$$1.25 \times P_u = 0.4 \times 30 (A_g - A_{sc}) + 0.67 \times 500 \times 0.03 A_g$$

On solving:

$$A_g = 206888.3126 \text{ mm}^2$$

So, we choose the column as,

$$= \sqrt{206888.3126} \text{ [square column]}$$

$$= 454.84 \text{ mm}$$

So, let the preliminary size of the column be 500 mm x 500 mm, which is subject to change in the detailed design.

For Building 2:

Height of floor to ceiling = $3.6 - 0.15 = 3.45$ m

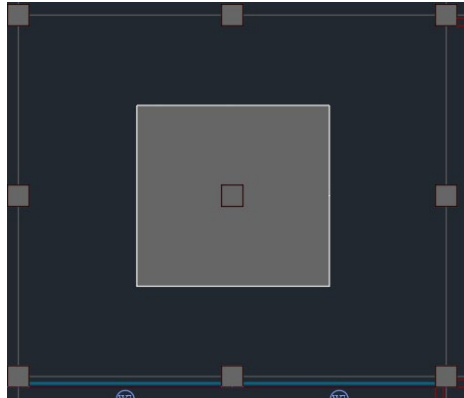

Figure 4: Influence Area for Column Design

Influence area for column = 32.5 m^2

LOAD CALCULATIONS

Dead Load (DL) = Area of the section x Specific weight x Depth of section

DL of slab (150 mm)

$$= 32.5 \times 0.15 \times 25 = 121.875 \text{ KN}$$

DL of ceiling plaster (12.5mm thick)

$$= 20.4 \times 0.0125 \times 32.5$$

$$= 8.28 \text{ KN}$$

DL of Beam

$$= 25 \times 0.3 \times (0.5 - 0.15) \times (6.5/2 + 6.5/2 + 5.5/2 + 4.5/2)$$

$$= 30.18 \text{ KN}$$

DL of floor finish (vitrified tile 10 mm thick)

$$= 24 \times 0.010 \times 32.5$$

$$= 7.8 \text{ KN}$$

DL of partition wall

$$= 20 \times (3.6 - 0.5) \times [(6.5 + 6.5 + 4.5 + 5.5)/2] \times 0.23$$

$$= 163.99 \text{ KN}$$

Assuming deduction for opening as 15%

$$\text{Total wall load} = 0.85 \times 163.99$$

$$= 139.4 \text{ KN}$$

Total dead load on the one intermediate floor panel

$$= 121.875 + 8.28 + 30.18 + 7.8 + 139.4$$

$$= 307.535 \text{ KN}$$

Self-weight of column = $0.50 \times 0.50 \times (3.6-0.15) \times 25 = 21.5625 \text{ KN}$

Total dead load = $(307.535 + 21.5625) \times 8 \text{ KN} = 2632.8 \text{ KN}$

Live Load = 4 KN/m^2

Live Load (LL) = $32.5 \text{ m}^2 \times 4$

= 130 KN

Applying live load reduction factor in accordance to IS 875 – Part 2 [clause 3.2.1 page12]

Total live load = $(130 \times 8) \times (1-0.4)$

= 624 KN

Total load on column = $2632.8 + 624$

= 3256.8 KN

Providing partial safety factor of 1.5

Total factored load = $1.5 \times 3256.8 = 4885.2 \text{ KN}$

From IS 456, page 71 clause [39.5]

Axial load on column (P_u) = $0.4 f_{ck} \times A_c + 0.67 f_y \times A_{sc}$ increasing P_u by

25% for earthquake resistance

Assuming 3% of cross- sectional area of column for reinforcement.

So,

$1.25 \times P_u = 0.4 \times 30(A_g - A_{sc}) + 0.67 \times 500 \times 0.03 A_g$

On solving we get

$A_g = 281535.27 \text{ mm}^2$

So, we choose the column as,

= $\sqrt{281535.27}$ [square column]

= 530.6 mm

So, let the preliminary size of the column be $550 \text{ mm} \times 550 \text{ mm}$, which is subject to change in the detailed design.

5. MODELING AND ANALYSIS IN ETABS

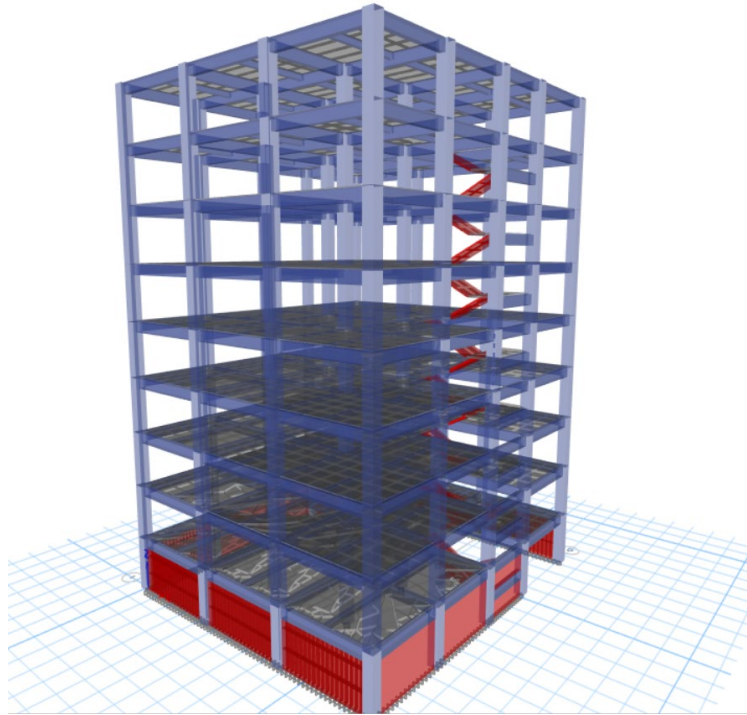

Figure 5: Rendered ETABS Model of Building 1

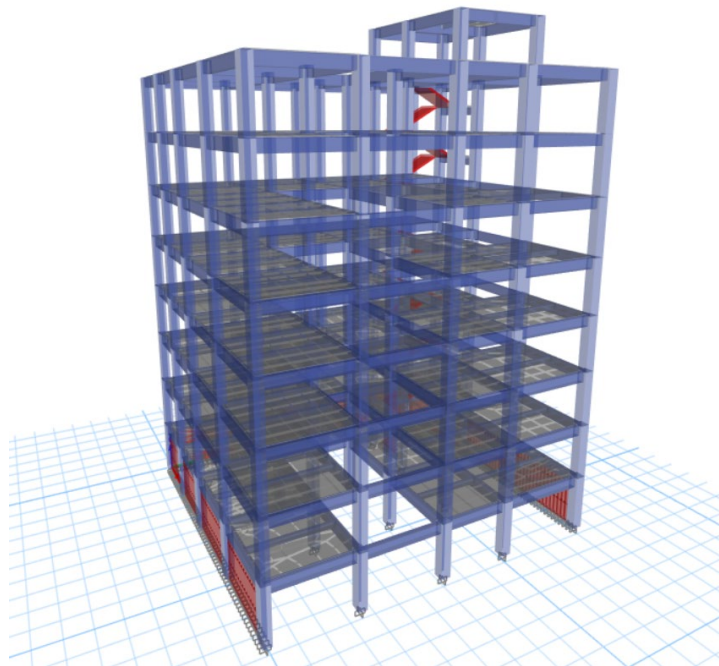

Figure 6: Rendered ETABS Model of Building 2

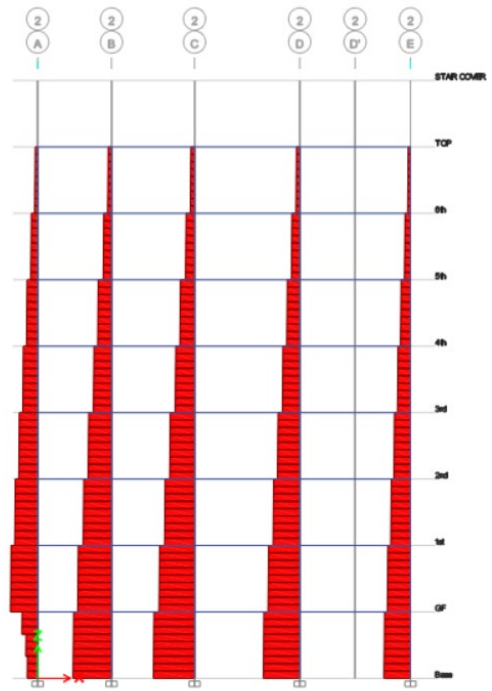
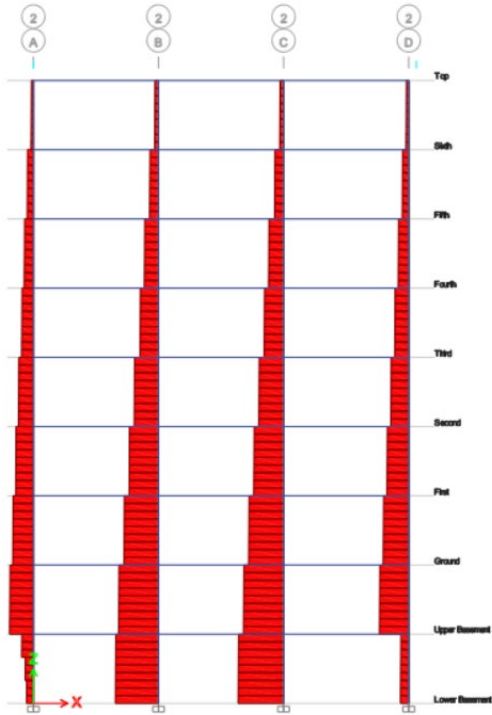

Figure 7: Axial Force Diagram of Building 2 Figure 8: Axial Force Diagram of Building 1

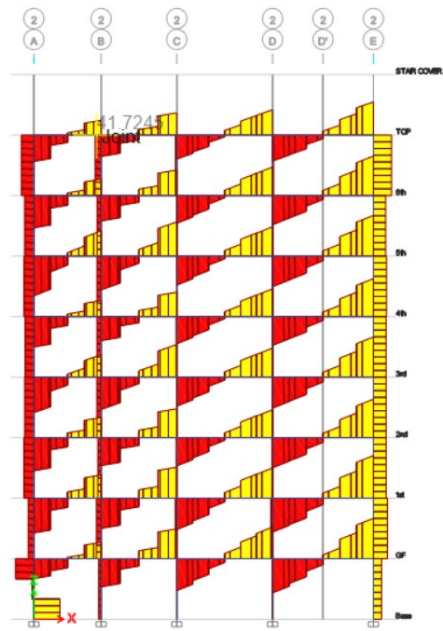
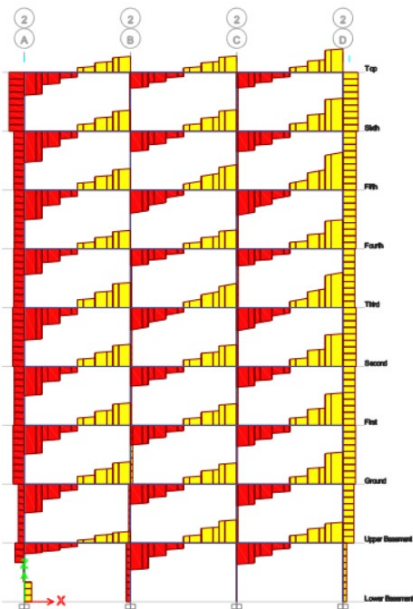

Figure 9: Shear Force Diagram in Building 2 Figure 10: Shear Force Diagram of Building 1

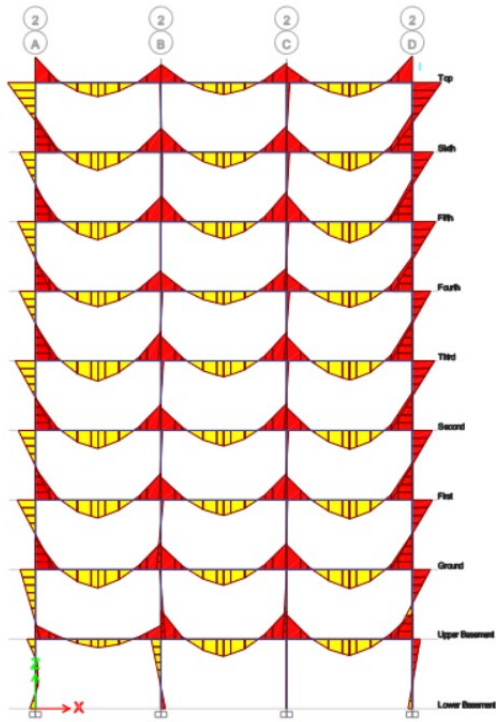

Figure 11: Bending Moment Diagram of Building 2

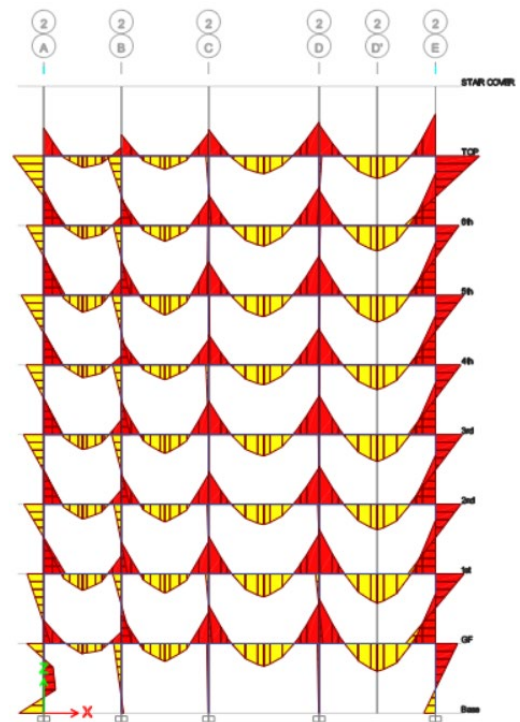

Figure 12: Bending Moment Diagram of Building 1

The above Axial Force Diagrams, Shear Force Diagrams, and Bending Moment Diagrams are all taken in load combination $1.5 \times (\text{Dead Load} + \text{Live Load})$.

6. CALCULATIONS

6.1 Seismic Gap Calculation

As per IS 1893:2016, cl. 7.11.3, two adjacent buildings or two adjacent units of the same building with a separation joint in between shall be separated by a distance equal to R times the sum of the calculated story displacements.

In X-direction:

Displacement at top of building 1 = 45 mm

Displacement at top of building 2 = 83.725mm

Provided separation = $R * (\Delta_1 + \Delta_2)$

$$= 643.25 \text{ mm}$$

Provide a separation of 650mm between the adjacent buildings.

6.2 Soft Storey Check

Building 1:

Table 5: Soft Storey Check for Building 1

Storey	Lateral Stiffness	Ki/Ki+1	Lateral Stiffness NOT less than 70% of story above	Lateral Stiffness	Ki/Ki+1	Lateral Stiffness NOT less than 70% of story above
Top	126933.184		Regular	162228.4		
Sixth	165606.272	1.304673	Regular	227898.8	1.404802	Regular
Fifth	178583.452	1.078362	Regular	241286.6	1.058745	Regular
Fourth	180757.164	1.012172	Regular	241736.8	1.001866	Regular
Third	185511.807	1.026304	Regular	245060.8	1.01375	Regular
Second	194335.388	1.047563	Regular	251031.3	1.024363	Regular
First	232668.271	1.197251	Regular	284848.2	1.134712	Regular
Ground	466539.046	2.005168	Regular	531092.3	1.864475	Regular

Upper Basement	3974925.34	8.520027	Regular	7236792	13.62624	Regular
----------------	------------	----------	---------	---------	----------	---------

Building 2:

Table 6: Soft Storey Check for Building 2

Storey	Lateral Stiffness	Ki/Ki+1	Lateral Stiffness NOT less than 70% of story above	Lateral Stiffness	Ki/Ki+1	Lateral Stiffness NOT less than 70% of story above
Stair Cover	54528.492		Regular	44016.84		Regular
Top	246858.914	4.527155	Regular	200335.7	4.551343	Regular
Sixth	323021.786	1.308528	Regular	243602.2	1.21597	Regular
Fifth	340987.847	1.055619	Regular	258434.1	1.060886	Regular
Fourth	343756.154	1.008118	Regular	261823.3	1.013114	Regular
Third	355141.757	1.033121	Regular	266534	1.017992	Regular
Second	403550.404	1.136308	Regular	306912.8	1.151496	Regular
First	804279.503	1.993009	Regular	548992.7	1.788758	Regular
Ground	17729504	22.04396	Regular	6272682	11.4258	Regular

6.3 Eccentricity Check

Building 1:

Table 7: Eccentricity Check for Building 1

Floor	XCCM	YCCCM	Xcr	Ycr	ex	ex(perm)	ey	ey(perm)	Remarks
Top	10.0806	10.7394	11.0177	10.8299	0.9371	2.925	0.0905	3.225	OK
Sixth	9.9874	10.6505	11.1601	10.8557	1.1727	2.925	0.2052	3.225	OK
Fifth	10.1251	10.6973	11.19	10.8577	1.0649	2.925	0.1604	3.225	OK
Fourth	10.2154	10.7641	11.1959	10.8522	0.9805	2.925	0.0881	3.225	OK
Third	10.2103	10.7897	11.1747	10.8426	0.9644	2.925	0.0529	3.225	OK
Second	10.2117	10.8302	11.1035	10.8246	0.8918	2.925	-0.0056	3.225	OK
First	10.2296	10.8426	10.9411	10.7866	0.7115	2.925	-0.056	3.225	OK
Ground	10.2218	10.8499	10.6167	10.6889	0.3949	2.925	-0.161	3.225	OK

Upper Basement	10.27	10.8173	8.7091	10.5441	1.5609	2.925	-0.2732	3.225	OK
----------------	-------	---------	--------	---------	--------	-------	---------	-------	----

Building 2:

Table 8: Eccentricity Check for Building 2

Floor	XCCM	YCCM	Xcr	Ycr	ex	ex (perm)	ey	ey (perm)	Remarks
STAIR COVER	9.0765	18.4927	8.8597	15.7774	-0.2168	3.03	-2.7153	3.225	Ok
TOP	9.412	11.7836	8.772	12.5006	-0.64	3.03	0.717	3.225	Ok
6th	9.2863	11.1716	8.7665	12.5024	-0.5198	3.03	1.3308	3.225	Ok
5th	9.296	10.9204	8.7559	12.5117	-0.5401	3.03	1.5913	3.225	Ok
4th	9.2738	10.8304	8.7349	12.4757	-0.5389	3.03	1.6453	3.225	Ok
3rd	9.2729	10.7749	8.692	12.3434	-0.5809	3.03	1.5685	3.225	Ok
2nd	9.2769	10.7471	8.5824	12.0256	-0.6945	3.03	1.2785	3.225	Ok
1st	9.2535	10.7005	8.1221	11.3554	-1.1314	3.03	0.6549	3.225	Ok
GF	9.231	10.6367	0.2447	9.9288	-8.9863	3.03	-0.7079	3.225	Ok

6.4 Calculation of Design Eccentricity

Building 1:
X-direction

Table 9: Calculation of Design Eccentricity of Building 1 in X direction

Story	XCM	XCR	Esi-x	edi-x(from COR)		edi-x(from COM)		Percentage	
				Positive	Negative	Positive	Negative	Positive	Negative
Top	10.0806	11.0177	0.9371	2.38065	-0.0379	1.44355	-0.975	7.402821	-5
Sixth	9.9249	11.1601	1.2352	2.8278	0.2602	1.5926	-0.975	8.167179	-5
Fifth	10.3639	11.19	0.8261	2.21415	-0.1489	1.38805	-0.975	7.118205	-5
Fourth	10.4848	11.1959	0.7111	2.04165	-0.2639	1.33055	-0.975	6.823333	-5
Third	10.1926	11.1747	0.9821	2.44815	0.0071	1.46605	-0.975	7.518205	-5
Second	10.2178	11.1035	0.8857	2.30355	-0.0893	1.41785	-0.975	7.271026	-5
First	10.331	10.9411	0.6101	1.89015	-0.3649	1.28005	-0.975	6.564359	-5

Ground	10.171	10.6167	0.4457	1.64355	-0.5293	1.19785	-0.975	6.142821	-5
Upper Basement	10.5998	8.7091	1.8907	-0.9157	-3.81105	0.975	-1.92035	5	-9.84795
							Average	7.125994	-5

Y-direction:

Table 10: Calculation of Design Eccentricity of Building 1 in Y direction

Story	YCM m	YCR m	Esi-y	edi-y(from COR)		edi-x(from COM)		Percentage	
				Positive	Negative	Positive	Negative	Positive	Negative
Top	10.7394	10.8299	0.0905	1.21075	-0.9845	1.12025	-1.075	5.210465	-5
Sixth	10.5909	10.8557	0.2052	1.3828	-0.8698	1.1776	-1.075	5.477209	-5
Fifth	10.7785	10.8577	0.1604	1.3156	-0.9146	1.1552	-1.075	5.373023	-5
Fourth	10.9636	10.8522	0.0881	1.20715	-0.9869	1.11905	-1.075	5.204884	-5
Third	10.8797	10.8426	0.0529	1.15435	-1.0221	1.10145	-1.075	5.123023	-5
Second	11.0116	10.8246	0.0056	1.0694	-1.0834	1.075	-1.0778	5	-5.01302
First	10.913	10.7866	-0.056	1.019	-1.159	1.075	-1.103	5	-5.13023
Ground	10.8975	10.6889	-0.161	0.914	-1.3165	1.075	-1.1555	5	-5.37442
Upper Basement	10.5939	10.5441	0.2732	0.8018	-1.4848	1.075	-1.2116	5	-5.63535
							Average	5.154289	-5.12811

Building 2:

X-direction

Table 11: Calculation of Design Eccentricity of Building 2 in X direction

Story	XCM m	XCR m	esi-x	percentage	edi-x(from Cor)		edi-x(from com)		percentage	
					positive	negative	positive	negative	positive	negative
Stair Cover	9.0765	8.8597	0.2168	1.073267	1.3352	-0.7932	1.1184	-1.01	5.536634	-5
TOP	9.517	8.772	0.745	3.688119	2.1275	-0.265	1.3825	-1.01	6.844059	-5
6th	9.2497	8.7665	0.4832	2.392079	1.7348	-0.5268	1.2516	-1.01	6.19604	-5

5th	9.3902	8.7559	0.6343	3.140099	1.96145	-0.3757	1.32715	-1.01	6.57005	-5
4th	9.2889	8.7349	0.554	2.742574	1.841	-0.456	1.287	-1.01	6.371287	-5
3rd	9.3457	8.692	0.6537	3.236139	1.99055	-0.3563	1.33685	-1.01	6.618069	-5
2nd	9.3745	8.5824	0.7921	3.921287	2.19815	-0.2179	1.40605	-1.01	6.960644	-5
1st	9.1948	8.1221	1.0727	5.310396	2.61905	0.0627	1.54635	-1.01	7.655198	-5
									6.593998	-5

Y-direction:

Table 12: Calculation of Design Eccentricity of Building 2 in Y direction

Story	YCM m	YCR m	esi-y	percentage	edi-y (from COR)		edi-y (from com)		percentage	
					positive	negative	positive	negative	positive	negative
Stait Cover	18.4927	15.7774	2.7153	12.6293	5.14795	1.6403	2.43265	-1.075	11.31465	-5
TOP	10.6459	12.5006	1.8547	-8.62651	-0.7797	3.85705	1.075	2.00235	5	9.31326
6th	10.4253	12.5024	2.0771	-9.66093	-1.0021	4.19065	1.075	2.11355	5	9.83047
5th	10.3175	12.5117	2.1942	-10.2056	-1.1192	-4.3663	1.075	-2.1721	5	10.1028
4th	10.3766	12.4757	2.0991	-9.76326	-1.0241	4.22365	1.075	2.12455	5	9.88163
3rd	10.4163	12.3434	1.9271	-8.96326	-0.8521	3.96565	1.075	2.03855	5	9.48163
2nd	10.4565	12.0256	1.5691	-7.29814	-0.4941	3.42865	1.075	1.85955	5	8.64907
1st	10.2817	11.3554	1.0737	-4.99395	0.0013	2.68555	1.075	1.61185	5	7.49698
									5	9.25083

6.5 Storey Drift Check

Building 1:

Table 13: Storey Drift Check for Building 1

Storey	X-direction (Eqx)	Y-direction (Eqy)	Permissible	Remarks
Top	0.001395	0.001113	0.004	Ok
Sixth	0.002189	0.001801	0.004	Ok
Fifth	0.002909	0.002411	0.004	Ok
Fourth	0.003432	0.002846	0.004	Ok
Third	0.00376	0.003126	0.004	Ok
Second	0.003849	0.003222	0.004	Ok
First	0.003525	0.002996	0.004	Ok
Ground	0.002206	0.001872	0.004	Ok
Upper Basement	0.000305	0.000038	0.004	Ok
Lower Basement	0	0	0.004	Ok

Building 2:

Table 14: Storey Drift Check for Building 2

Floor	X-direction (Eqx)	Y-direction (Eqy)	Permissible	Remarks
Stair Cover	0.00076	0.000946	0.004	OK
Top	0.00097	0.001233	0.004	OK
6th	0.001473	0.001835	0.004	OK
5th	0.00192	0.002355	0.004	OK
4th	0.002213	0.002692	0.004	OK
3rd	0.002333	0.002843	0.004	OK
2nd	0.002186	0.002717	0.004	OK
1st	0.001392	0.001905	0.004	OK
GF	0.000052	0.00016	0.004	OK
Base	0	0	0.004	OK

6.6 Torsional Irregularity Check

Building 1:

X-direction:

Table 15: Torsional Irregularity Check for Building 1 in X-direction

	X-direction(Eqx)			
Floor	Xmax	Xmin	1.5*Xmin	Remarks
Top	83.726	82.429	123.64	Ok
Sixth	78.713	77.492	116.238	Ok
Fifth	70.842	69.88	104.82	Ok
Fourth	60.375	59.742	89.613	Ok
Third	48.021	47.697	71.545	Ok
Second	34.481	34.421	51.6315	Ok
First	20.618	20.745	31.1175	Ok
Ground	7.92	8.088	12.132	Ok

Y-direction:

Table 16: Torsional Irregularity Check for Building 1 in Y-direction

Floor	Ymax	Ymin	1.5*Ymin	Remarks
Top	69.77	58.33	87.495	Ok
Sixth	65.772	54.544	81.816	Ok
Fifth	59.302	48.986	73.479	Ok
Fourth	50.637	41.81	62.715	Ok
Third	40.408	33.439	50.158	Ok
Second	29.173	24.304	36.456	Ok
First	17.591	14.879	22.3185	Ok
Ground	6.818	5.949	8.9235	Ok

Building 2:
X-direction:

Table 17: Torsional Irregularity Check for Building 2 in X-direction

		X-direction(Eqx)		
Floor	Xmax	Xmin	1.5*Xmin	Remarks
Top	45.003	37.883	56.8125	Ok
Sixth	41.519	34.463	51.6945	Ok
Fifth	36.231	29.758	44.637	Ok
Fourth	29.334	24.015	36.0225	Ok
Third	21.388	17.65	26.475	Ok
Second	13.01	11.028	16.542	Ok
First	5.161	4.648	6.972	Ok
Ground	0.162	0.189	0.2835	Ok

Y-direction:

Table 18: Torsional Irregularity Check for Building 2 in Y-direction

Floor	Ymax	Ymin	1.5*Ymin	Remarks
Top	56.729	52.646	78.969	Ok
Sixth	52.288	48.607	72.9105	Ok
Fifth	45.677	42.508	63.762	Ok
Fourth	37.192	34.609	51.9135	Ok
Third	27.489	25.522	38.283	Ok
Second	17.24	15.879	23.8135	Ok
First	7.446	6.619	9.9285	Ok
Ground	0.578	0.42	0.63	Ok

6.7 Modal Analysis Results

Building 1:

Table 19: Modal Analysis Results for Building 1

Case	Mode	Period	UX	UY	RZ	SumUX	SumUY	SumRZ
		sec						
Modal	1	1.697	0.6879	0.0001	0.0001	0.6879	0.0001	0.0001
Modal	2	1.523	0.0002	0.5317	0.1505	0.6881	0.5317	0.1506
Modal	3	1.359	0.0001	0.1597	0.523	0.6882	0.6914	0.6736
Modal	4	0.535	0.0917	0.00001963	4.25E-05	0.7799	0.6914	0.6736
Modal	5	0.484	0.000002668	0.0747	0.0157	0.7799	0.7661	0.6893
Modal	6	0.436	0.0001	0.0165	0.0726	0.7799	0.7826	0.7619
Modal	7	0.286	0.0364	0.0001	0.0001	0.8164	0.7827	0.762

Modal	8	0.262	0.0000243	0.0329	0.0021	0.8164	0.8156	0.7641
Modal	9	0.242	0.0001	0.0018	0.0331	0.8165	0.8174	0.7972
Modal	10	0.185	0.0213	0.0001	0.0001	0.8378	0.8174	0.7972
Modal	11	0.173	0.00003327	0.0202	0.0002	0.8378	0.8376	0.7975
Modal	12	0.159	0.00004708	0.0002	0.0205	0.8378	0.8379	0.8179
Modal	13	0.128	0.0132	0.00001803	0.0001	0.851	0.8379	0.818
Modal	14	0.122	0.00001006	0.0128	2.12E-05	0.851	0.8507	0.818
Modal	15	0.112	0.00004795	0.00003007	0.013	0.8511	0.8507	0.831
Modal	16	0.097	0.0074	0.000004761	7.97E-06	0.8585	0.8507	0.831
Modal	17	0.093	0.000002687	0.0071	2.76E-06	0.8585	0.8579	0.831
Modal	18	0.085	0.00001384	0.00003116	0.0076	0.8585	0.8579	0.8386
Modal	19	0.077	0.0044	0.000003428	1E-05	0.8629	0.8579	0.8386
Modal	20	0.075	0.000002584	0.0044	2.59E-06	0.8629	0.8622	0.8386
Modal	21	0.069	0.000009847	0	0.0043	0.8629	0.8622	0.8429
Modal	22	0.067	0.0009	0.00000327	0	0.8639	0.8622	0.8429
Modal	23	0.065	0.00000281	0.0009	1.54E-05	0.8639	0.8631	0.8429
Modal	24	0.06	0.000009218	0	0.0009	0.8639	0.8631	0.8439
Modal	25	0.045	0.0043	0.00003015	2.25E-05	0.8681	0.8632	0.8439
Modal	26	0.032	0.0008	0.00001114	4.61E-05	0.8689	0.8632	0.8439
Modal	27	0.032	0.0012	0.00001249	0.0001	0.8701	0.8632	0.844

Building 2:

Table 20: Modal Analysis Results for Building 2

Case	Mode	Period	UX	UY	RZ	SumUX	SumUY	SumRZ
		sec						
Modal	1	1.311	0.002	0.6951	0.0119	0.002	0.6951	0.0119
Modal	2	1.168	0.4909	0.0084	0.1929	0.4929	0.7035	0.2048
Modal	3	1.036	0.2048	0.0034	0.4908	0.6977	0.7069	0.6956
Modal	4	0.417	0.0002	0.0938	0.0009	0.6979	0.8007	0.6965
Modal	5	0.364	0.0739	0.0006	0.0209	0.7718	0.8013	0.7174
Modal	6	0.333	0.0228	0.0002	0.0703	0.7946	0.8015	0.7877

Modal	7	0.233	0.0001	0.0361	4.47E-05	0.7947	0.8376	0.7877
Modal	8	0.2	0.0346	0.0001	0.0001	0.8294	0.8377	0.7878
Modal	9	0.191	0.0001	0.0000016	0.0343	0.8294	0.8377	0.8221
Modal	10	0.159	0.0001	0.0193	0.0001	0.8295	0.8571	0.8222
Modal	11	0.139	0.0129	0.0003	0.0049	0.8424	0.8573	0.8271
Modal	12	0.126	0.003	0.0092	0.0042	0.8454	0.8665	0.8313
Modal	13	0.125	0.0035	0.0033	0.0107	0.8488	0.8698	0.842
Modal	14	0.113	0.0061	0.0002	2.41E-05	0.8549	0.87	0.842
Modal	15	0.105	0.0031	0.000008524	0.0075	0.858	0.87	0.8495
Modal	16	0.096	0.00004242	0.0118	4.31E-05	0.858	0.8818	0.8496
Modal	17	0.085	0.0087	0	0.003	0.8667	0.8818	0.8526
Modal	18	0.082	0.0016	0.0003	0.0077	0.8683	0.8821	0.8603
Modal	19	0.076	0.00002351	0.0078	1.25E-06	0.8683	0.8899	0.8603
Modal	20	0.068	0.0049	0.0002	0.0007	0.8732	0.89	0.8609
Modal	21	0.065	0.0012	0.0012	0.0051	0.8743	0.8912	0.8661
Modal	22	0.064	0.0001	0.0016	0.0008	0.8744	0.8928	0.8668
Modal	23	0.058	0.001	0.0002	0.0005	0.8754	0.893	0.8673
Modal	24	0.055	0.0006	0.0007	0.0016	0.876	0.8937	0.8689
Modal	25	0.05	0.00004382	0.0286	0.0008	0.876	0.9223	0.8697
Modal	26	0.046	0.0001	0.0517	0.0085	0.8761	0.974	0.8782
Modal	27	0.041	0.0001	0.008	0.0024	0.8762	0.982	0.8806
Modal	28	0.03	0.1223	0.0005	2.25E-05	0.9985	0.9825	0.8806
Modal	29	0.022	0.0004	0.0165	0.1155	0.9989	0.9991	0.9961
Modal	30	0.019	0.00000259	0.0008	0.0031	0.9989	0.9999	0.9992

7. STRUCTURAL DESIGN

7.1 Design of structural elements

The design section is the most important part. The design of the structural elements should be done for durability, construction, and use throughout the service life of the structure. The realization of design objectives requires compliance with clearly defined standards for materials, production, workmanship, and maintenance as well.

This chapter includes the design processes for sample elements including slab, beam, column, staircase, basement wall, lift wall, mat foundation, and ramp.

1. Design of Slab
2. Design of Beam
3. Design of Column
4. Design of Staircase
5. Design of Basement Wall
6. Design of Lift Wall
7. Design of Mat Foundation
8. Design of Ramp

7.2 Design of Slab

RCC slabs are designed on the assumption that they consist of a number of series of beams having a width of one meter, even though it is cast monolithic. They are the plate elements forming floors and roofs of building and carrying distributed loads primarily by flexure. They may be supported by beams or walls or columns and may be used as the flange of T or L-beam. Slab may be simply supported or continuous over one or more supports and is classified according to the manner of support as: one-way slabs spanning in one direction, two-way slab spanning in directions, circular slabs, and grid floor slabs resting directly on columns with no beams and grid floor and ribbed slabs.

Important information regarding the design of slab according to IS456:2000

1. Slab is designed for 1m wide strip
2. $A_{st\ min} = 0.12\% bD$ for deformed bars (Cl.26.5.2.1)
3. Cover = 15mm
4. If $L_y/L_x < 2$, two way slab is designed

Compression reinforcement is used only in exceptional cases in a slab. Shear stresses are usually very low and shear reinforcements are never provided in slabs. It is preferred to increase the depth of a slab and hence reduce the shear stress rather than provide shear reinforcement. Temperature reinforcement is invariably provided at right angles to the main longitudinal reinforcement in a slab. There are two types of slabs described as follow:

1. One-way slab

These slabs have length more than twice the breadth and may be simply supported or continuous or can be analyzed in a manner similar to that for continuous beams. It consists of main reinforcement spanning between the supports (shorter of the length and breadth) with distribution or temperature reinforcement at right angles to it.

2. Two-way slab

The slab is said to be spanning in two directions, when the length to breadth ratio falls below 2. The deflection and bending moments in a two-way slab are considerably reduced as compared to those in one-way slab. In a square slab, the two-way action is equal in each direction. In such a case, main reinforcement is provided in both directions in the form of a mesh.

Slab Design for Building 2

Critical Slab ID:CD-34

Checking for One way or two-way slab;

$$L = 5.7 \text{ m}, b = 4.5 \text{ m}$$

$$\frac{b}{L} = 1.267 \leq 2,$$

Hence, Two-way slab.

The indicated slab is type 3 i.e., one long edge discontinuous.

We have,

$$D = 150 \text{ mm}$$

$$\emptyset = 10 \text{ mm}$$

$$\text{Clear cover} = 15 \text{ mm}$$

$$d = 150 - 15 - 5$$

$$= 130 \text{ mm}$$

Effective Span:

(Short and Long Span)

$l_x = l_c + d$ or difference between support.

$$\begin{aligned} \text{Or, } l_x &= 4.5 + 0.13 \text{ or } (4.5 + 0.35), l_y = 5.7 + 0.12 \text{ or } (5.7 + 0.35) \\ &= 4.63 \text{ or } 4.85 & & = 5.82 \text{ or } 6.05 \end{aligned}$$

$$\therefore l_x = 4.63 \text{ m, } l_y = 5.82 \text{ m}$$

Load Calculation:

The two-way slab is designed considering a 1.0 m wide strip along the short and long span.

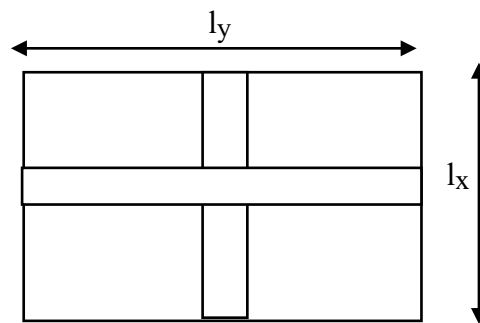

Figure 13: Design Strip for Slab

$$\text{Dead Load of Slab} = 25 * 0.150 * 1 = 3.75 \text{ KN/m}$$

$$\text{Floor Finish} = 1 \text{ KN/m}^2 * 1 = 1 \text{ KN/m}$$

$$\begin{aligned} \text{Partition Wall} &= 1.67 \text{ KN/m}^2 * 1 \\ &= 1.67 \text{ KN/m} \end{aligned}$$

$$\begin{aligned} \text{Live Load of Slab} &= 5 \text{ KN/m}^2 * 1 \\ &= 5 \text{ KN/m} \end{aligned}$$

$$\text{Total Load} = 11.42 \text{ KN/m}$$

$$\therefore \text{Factored Load} = 1.5 * 11.42 = 17.13 \text{ KN/m}$$

Bending Moment along Short and Long Span:

(ANNEX D IS 456: 2000)

$$\therefore M_x = \alpha_x W l_x^2 \quad \& \quad M_y = \alpha_y W l_x^2$$

Where, α_x and α_y are bending moments coefficients along short and long span.

Depends on $\frac{l_x}{l_y}$ Table 26.

$$\frac{l_y}{l_x} = 1.257$$

For slab of type 3, one long edge discontinuous.

$$\alpha_x^{+ve} = 0.0418$$

$$\alpha_y^{+ve} = 0.028$$

$$\alpha_x^{-ve} = 0.054$$

$$\alpha_y^{-ve} = 0.037$$

$$\text{Hence, } M_x^{+ve} = 0.0418 * 17.13 * 4.63^2 = 15.34 \text{ KNm}$$

$$M_x^{-ve} = 0.054 * 17.13 * 4.63^2 = 19.82 \text{ KNm}$$

$$M_y^{+ve} = 0.028 * 17.13 * 4.63^2 = 10.28 \text{ KNm}$$

$$M_y^{-ve} = 0.037 * 17.13 * 4.63^2 = 13.58 \text{ KNm}$$

$$\therefore \text{BM}_{\max} = 19.82 \text{ KNm}$$

The effective depth of slab from consideration of Limit State of Collapse, since, slab is designed as singly reinforced balanced section.

For Fe 500,

$$M_{\text{limit}} = 0.133 f_{ck} b d^2$$

$$d = \sqrt{\frac{19.82 * 1000000}{0.133 * 30 * 1000}}$$

$$= 70.47 \text{ mm} \cong 75 \text{ mm.}$$

$$\text{Overall depth (D)} = 75 + 15 + 5$$

$$= 95 \text{ mm} < 150 \text{ (adopted depth) OK.}$$

Note: Thickness of RCC slab $\nless 100\text{mm}$.

Provide Overall Depth of (D) = 150 mm.

$$\therefore d = 150 - 15 - 5 = 130 \text{ mm}$$

\therefore Area of steel (tensile reinforcement) along short and long span

We have,

$$M_x^{+ve} = 0.87 f_y A_{stx}^{+ve} (d - f_y A_{stx}^{+ve} / f_{ck} b)$$

$$15.34 * 10^6 = 0.87 * 500 * A_{stx}^{+ve} \left(130 - \frac{500 * A_{stx}^{+ve}}{30 * 1000} \right)$$

$$\therefore A_{stx}^{+ve} = 281.41 \text{ mm}^2/\text{m}$$

$$\begin{aligned} \text{Providing 10 mm bars @ Spacing(S)} &= \frac{b * a_{st}}{A_{st}} \quad ; \quad a_{st} = \frac{\pi * 10^2}{4} = 78.54 \text{ mm}^2 \\ &= \frac{1000 * 78.54}{281.41} \end{aligned}$$

$$= 279 \text{ mm}$$

Taking $S = 125\text{mm}$

$$\begin{aligned} \therefore \text{ Giving trial } A_{\text{stx}}^{+\text{ve}} &= \frac{b \cdot a \cdot s \cdot t}{s} = \frac{1000 \cdot 78.54}{125} \\ &= 628.32 \text{ mm}^2/\text{m} > 279 \text{ mm}^2/\text{m} \\ &\text{OK.} \end{aligned}$$

Similarly;

For $A_{\text{stx}}^{-\text{ve}}$

$$A_{\text{stx}}^{-\text{ve}} = 367.83 \text{ mm}^2$$

$$\begin{aligned} \text{Provide 10 mm dia. bars @ } S &= \frac{b \cdot a \cdot s \cdot t}{A_{\text{st}}} = \frac{1000 \cdot 78.54}{367.83} \\ &= 213.52 \text{ mm} \end{aligned}$$

Provide $\approx 125 \text{ mm}$

$$A_{\text{stx}}^{-\text{ve}} \text{ provided} = \frac{1000 \cdot 78.54}{150} = 628.32 \text{ mm}^2/\text{m} > 367.83 \text{ mm}^2/\text{m}$$

OK.

Now,

$$\begin{aligned} M_y^{+\text{ve}} &= 0.87 f_y A_{\text{sty}}^{+\text{ve}} \left(d' - \frac{f_y A_{\text{sty}}^{+\text{ve}}}{f_{ck} b} \right) \\ d' &= d - \frac{\phi}{2} - \frac{\phi}{2} = 130 - 5 - 5 = 120 \text{ mm.} \end{aligned}$$

$$\therefore A_{\text{sty}}^{+\text{ve}} = 202.63 \text{ mm}^2/\text{m}.$$

$$\begin{aligned} \text{Providing 10 mm dia. bars @ } S &= \frac{b \cdot a \cdot s \cdot t}{A_{\text{st}}} = \frac{1000 \cdot 78.54}{202.63} \\ &= 387.58 \text{ mm} \end{aligned}$$

Take $S = 125\text{mm}$

$$\therefore A_{\text{sty}}^{+\text{ve}} \text{ provided} = \frac{1000 \cdot 78.54}{125} = 628.32 \text{ mm}^2/\text{m} > 202.63 \text{ mm}^2/\text{m}$$

Again,

$$A_{\text{sty}}^{-\text{ve}}; d' = 120 \text{ mm}.$$

$$A_{\text{sty}}^{-\text{ve}} = 270.3 \text{ mm}^2/\text{m}$$

$$\begin{aligned} \therefore \text{ Providing 10 mm dia. bars @ } S &= \frac{b \cdot a \cdot s \cdot t}{A_{\text{st}}} = \frac{1000 \cdot 78.54}{270.3} \\ &= 290.56 \text{ mm} \end{aligned}$$

$$\therefore A_{\text{sty}}^{-\text{ve}} \text{ provided} = \frac{1000 \cdot 78.54}{125} = 628.32 \text{ mm}^2/\text{m} > 270.3 \text{ mm}^2/\text{m}$$

Check for (A_{st}) min: Clause 26.5.2.1 IS 456: 2000

For HYSD; (A_{st}) min $\nless 0.12$ % of bD

$$\nless 0.12 / 100 * 1000 * 150$$

$$\nless 180 \text{ mm}^2$$

The provided A_{st} along long and short span is greater than 180 mm^2

Hence, OK.

Distribution of area of steel (ANNEX D – 1.2):

The two-way continuous slab is divided into middle strip and edge strip along short and long span. The maximum A_{st} is provided on the middle strip and A_{st} min. is provided in edge strip.

$$l_x = 4.63 \text{ m}$$

$$l_y = 5.82 \text{ m}$$

Check for Deflection:

$$\frac{l}{d} \leq \alpha\beta\gamma\delta\lambda \text{ Where, } \alpha = \frac{20+26}{2} = 23, \beta = 1, \delta = 1, \lambda = 1,$$

γ = modification factor for tensile rebars depending on pt % and fs Table 19 IS 456: 2000.

$$\therefore \frac{A_{st} * 100 \%}{bd} = \text{pt.} = \frac{628.32 * 100\%}{1000 * 150}$$
$$\text{pt.} = 0.41\%$$

$$fs = 0.58f_y \frac{A_{st \text{ required}}}{A_{st \text{ provided}}}$$
$$= 0.58 * 500 * \frac{281.41}{628.32}$$
$$= 129.88$$

From figure 4, IS 456: 2000;

$$\gamma = 2$$

$$\therefore \text{permissible value} = \alpha\beta\gamma\delta\lambda$$
$$= 23 * 2 * 1 * 1 * 1$$
$$= 46$$

$$\text{Actual value} = \frac{l}{d} = \frac{4630}{130} = 35.61$$

$$\therefore \frac{l}{d} \leq \alpha\beta\gamma\delta\lambda$$

OK.

Check for Shear:

$$\tau_v = \frac{Vu}{bd} = \frac{17.13 \times 4.63 / 2 \times 1000}{1000 \times 130} = 0.305$$

$$V_u = \frac{Wu \cdot lx}{2} = \frac{17.13 \times 4.63}{2} = 39.65 \text{ KN}$$

$$100 \text{ As}/bd = 100 \times (0.5 \times 628.32) / (1000 \times 130) \\ = 0.24\%$$

Again, from Table 19,

$$\therefore \tau_c = 0.37 \text{ N/mm}^2$$

$$\tau_c = k \cdot 0.37$$

$$= 1.3 \cdot 0.37$$

$$= 0.481$$

Hence, the slab is safe against shear.

Check for L_D :

At simply supported edge;

$$L_D \leq 1.3 \frac{M_1}{V_u} + L_0$$

$$L_D = \frac{0.87 f_y A_{st} Z}{V} = \frac{0.87 f_y \phi}{\tau b D}$$

$$\text{For M30, } \tau b D = 1.5 \cdot 1.6 = 2.4$$

$$\therefore M_1 = 0.87 f_y A_{st} \left(d - \frac{f_y A_{st}}{f_{ck} b} \right)$$

$$= 0.87 \cdot 500 \cdot 523.6/2 \cdot \left(130 - \frac{500 \cdot 628.32}{2 \cdot 30 \cdot 1000} \right)$$

$$= 17.05 \cdot 10^6 \text{ Nmm} = 17.05 \text{ KNm}$$

And, $V_u = 39.65 \text{ KN}$

Now,

$$L_D = \frac{0.87 f_y A_{st} Z}{V} = \frac{0.87 f_y \phi}{\tau b D}$$

$$= 0.87 \cdot 500 \cdot 10 / (1.5 \cdot 1.6)$$

$$= 453.125 \text{ mm}$$

$$1.3 \frac{M_1}{V_u} = 550.01 \text{ mm}$$

(> L_d , also, no anchorage required)

OK.

Slab Design for Building 1

Critical Slab ID: S1-17

Checking for One way or two-way slab;

$$L = 4.5 \text{ m}, b = 3.25 \text{ m}$$

$$b/(L) = 1.38 \leq 2,$$

Hence, Two-way slab.

The indicated slab is type 1 i.e. interior panel.

Effective Depth of Slab from Control of Deflection Criteria:

$$l_x/d = \alpha\beta\gamma\delta\lambda$$

$$\alpha = (20+26)/2 = 23,$$

$$\beta = 1,$$

$$\delta = 1,$$

$$\lambda = 1,$$

$\gamma = 1.4$ for rectangular slab.

$$l_x/d = 4.5/d = 23 * 1 * 1 * 1.4 * 1$$

$$\therefore d = 4.5/32.2$$

$$d = 0.139 \text{ m},$$

$$\cong 140 \text{ mm}.$$

Provide overall depth (D) = $d + 15 \text{ mm} + \phi/2$

$$= 160 \text{ mm (Provide 10 mm bar, provide effective depth = 140mm)}$$

Effective Span:

(Short and Long Span)

$l_x = l_c + d$ or difference between support.

Or, $l_x = 4.5 + 0.14$ or $(4.5 + 0.65)$, $l_y = 3.25 + 0.14$ or $(3.25 + 0.65)$

$$= 4.64 \text{ or } 5.15$$

$$= 3. \text{ or } 3.9$$

$$\therefore l_x = 4.64 \text{ m}, l_y = 3.39 \text{ m}$$

Load Calculation:

The two-way slab is designed with considering a 1.0 m wide strip along the short and long span.

$$\text{Dead Load of Slab} = 25 * 0.160 * 1 = 4 \text{ KN/m}$$

$$\text{Floor Finish} = 1 \text{ KN/m}^2 * 1 = 1 \text{ KN/m}$$

$$\text{Partition Wall} = 1.67 \text{ KN/m}^2 * 1$$

$$= 1.67 \text{ KN/m}$$

$$\text{Live Load of Slab} = 5 \text{ KN/m}^2 * 1$$

$$= 5 \text{ KN/m}$$

$$\text{Total Load} = 11.67 \text{ KN/m}$$

$$\therefore \text{Factored Load} = 1.5 * 11.67 = 17.505 \text{ KN/m}$$

Bending Moment along Short and Long Span:

(ANNEX D IS 456: 2000)

$$\therefore M_x = \alpha_x W l_x^2 \quad \& \quad M_y = \alpha_y W l_x^2$$

Where, α_x and α_y are bending moments coefficients along short and long span.

Depends on $l_x/(l_y)$ Table 26.

$$l_x/(l_y) = 1.38$$

For slab of type 4, two adjacent edge discontinuous.

$$\alpha_{x+ve} = 0.0384$$

$$\alpha_{y+ve} = 0.024$$

$$\alpha_{x-ve} = 0.0502$$

$$\alpha_{y-ve} = 0.032$$

$$\text{Hence, } M_{x+ve} = 0.0384 * 17.505 * 4.642 = 14.48 \text{ KNm}$$

$$M_{x-ve} = 0.0502 * 17.505 * 4.642 = 18.92 \text{ KNm}$$

$$M_{y+ve} = 0.024 * 17.505 * 4.642 = 9.04 \text{ KNm}$$

$$M_{y-ve} = 0.032 * 17.505 * 4.642 = 12.06 \text{ KNm}$$

$$\therefore \text{BM}_{\text{max}} = 18.92 \text{ KNm}$$

The effective depth of slab from consideration of Limit State of Collapse, since, slab is designed as singly reinforced balanced section.

For Fe 500,

$$M_{\text{limit}} = 0.138 f_{ck} b d^2$$

$$d = \sqrt{((18.878 * 1000000) / (0.138 * 30 * 1000))}$$

$$= 67.52 \text{ mm} \cong 75 \text{ mm.}$$

$$\text{Overall depth (D)} = 75 + 15 + 5$$

$$= 95 \text{ mm} < 160 \text{ (assumed depth) OK.}$$

Note: Thickness of RCC slab < 100mm.

Provide Overall Depth of (D) = 150 mm.

$$\therefore d = 150 - 15 - 5 = 130 \text{ mm}$$

\therefore Area of steel (tensile reinforcement) along short and long span

We have,

$$M_{x+ve} = 0.87 f_y A_{stx+ve} (d - f_y A_{stx+ve} / f_{ck} b)$$

$$14.48 * 10^6 = 0.87 * 500 * A_{stx+ve} (130 - (500 * A_{stx+ve}) / (30 * 1000))$$

$$\therefore A_{stx+ve} = 265.06 \text{ mm}^2/\text{m}$$

$$\text{Providing 10 mm bars @ Spacing (S)} = (b * a_{st}) / A_{st} \quad ; \quad a_{st} = (\pi * 10^2) / 4 = 78.54 \text{ mm}^2$$

$$= (1000 * 78.54) / 265.06$$

$$= 296.3 \text{ mm}$$

$$\approx 290 \text{ mm}$$

Taking S = 125 mm

$$\therefore \text{ Giving trial } A_{stx+ve} = (b * a_{st}) / S = (1000 * 78.54) / 150$$

$$= 628.32 \text{ mm}^2/\text{m} > 265.06 \text{ mm}^2/\text{m}$$

OK.

Similarly;

A_{stx-ve}

$$A_{stx-ve} = 350.3 \text{ mm}^2$$

$$\text{Provide 10 mm dia. bars @ } S = (b * a_{st}) / A_{st} = (1000 * 78.54) / 350.3$$

$$= 224.2 \text{ mm}^2/\text{m}$$

Provide \approx 125 mm

$$A_{stx-ve} \text{ provided} = (1000 * 78.54) / 125 = 628.32 \text{ mm}^2/\text{m} > 350.3 \text{ mm}^2/\text{m} \quad (\text{OK})$$

Now,

$$M_{y+ve} = 0.87 f_y A_{sty+ve} (d' - (f_y A_{sty+ve}) / (f_{ck} b))$$

$$d' = d - \phi/2 - \phi/2 = 130 - 5 - 5 = 120 \text{ mm.}$$

$$\therefore A_{sty+ve} = 177.55 \text{ mm}^2/\text{m.}$$

$$\text{Providing 10 mm dia. bars @ } S = (b * a_{st}) / A_{st} = (1000 * 78.54) / 177.55$$

$$= 442.35 \text{ mm}$$

Take $S = 125 \text{ mm}$

$$\therefore \text{Asty+ve provided} = (1000 * 78.54) / 125 = 628.32 \text{ mm}^2/\text{m} > 177.55 \text{ mm}^2/\text{m}$$

Asty- ve ; $d' = 120 \text{ mm}$.

$$\text{Asty- ve} = 238.96 \text{ mm}^2/\text{m}$$

$$\begin{aligned} \therefore \text{Providing } 10 \text{ mm dia. bars @ } S &= (b * \text{ast}) / \text{Ast} = (1000 * 78.54) / 238.96 \\ &= 328.67 \text{ mm} \approx 300 \text{ mm} \end{aligned}$$

Provided spacing = 125mm

$$\therefore \text{Asty- ve provided} = (1000 * 78.54) / 125 = 628.32 \text{ mm}^2 > 238.96 \text{ mm}^2$$

Check for $(\text{Ast})_{\text{min}}$: Clause 26.5.2.1 IS 456: 2000

For HYSD; $(\text{Ast})_{\text{min}} < 0.12 \% \text{ of } bD$

$$< 0.12 / 100 * 1000 * 150$$

$$< 180 \text{ mm}^2$$

The provided Ast along long and short span is greater than 180 mm²

Distribution of area of steel (ANNEX D – 1.2):

The two way continuous slab is divided into middle strip and edge strip along short and long span. The maximum Ast is provided on the middle strip and Ast min. is provided in edge strip.

$$l_x = 4.64 \text{ m}$$

$$l_y = 3.39 \text{ m}$$

Check for Deflection:

$$l/d \leq \alpha \beta \gamma \delta \lambda \text{ Where, } \alpha = (20+26)/2 = 23, \beta = 1, \delta = 1, \lambda = 1,$$

γ = modification factor for tensile rebars depending on pt % and f_s Table 19 IS 456: 2000.

$$\therefore (\text{Ast} * 100 \%)/ (bd) = \text{pt.} = (628.32 * 100\%) / (1000 * 150)$$

$$\text{pt.} = 0.418\%$$

$$f_s = 0.58 f_y (\text{Ast required}) / (\text{Ast provided})$$

$$= 0.58 * 500 * 265.06 / 628.32$$

$$= 122.33$$

From figure 4, IS 456: 2000; $\gamma = 2$

$$\therefore \text{permissible value} = \alpha \beta \gamma \delta \lambda$$

$$= 23 * 2 * 1 * 1 * 1$$

$$= 46$$

$$\text{Actual value} = l/d = 4640/130 = 35.69$$

$$\therefore l/d \leq \alpha\beta\gamma\delta\lambda \quad (\text{OK})$$

Check for Shear:

$$\tau_v = V_u/bd = (17.505 \times 4.64/2 \times 1000)/(1000 \times 130) = 0.246$$

$$V_u = (W_u \times l_x)/2 = (17.505 \times 4.64)/2 = 40.61 \text{ KN}$$

$$100 A_s/bd = 100 \times (0.5 \times 628.32)/(1000 \times 130)$$

$$= 0.24\%$$

Again, from Table 19,

$$\therefore \tau_c = 0.37 \text{ N/mm}^2$$

$$\tau_c = k \times 0.37$$

$$= 1.3 \times 0.37$$

$$= 0.481$$

Hence, the slab is safe against shear.

Check for L_D

At simply supported edge;

$$L_D \leq 1.3M_1/V_u + L_0$$

$$L_D = (0.87 f_y A_{st} Z)/V = (0.87 f_y \phi)/(\tau bD)$$

$$\text{For M30, } \tau_{bd} = 1.5 \times 1.6 = 2.4$$

$$\therefore M_1 = 0.87 f_y A_{st} (d - (f_y A_{st})/(f_{ck} b))$$

$$= 0.87 \times 500 \times 628.32/2 \times (130 - (500 \times 628.32)/(2 \times 30 \times 1000))$$

$$= 17.05 \times 10^6 \text{ Nmm} = 17.05 \text{ KNm}$$

$$\text{And, } V_u = 40.61 \text{ KN}$$

Now,

$$L_D = (0.87 f_y A_{st} Z)/V = (0.87 f_y \phi)/(\tau bD)$$

$$= 0.87 \times 500 \times 10/(1.5 \times 1.6)$$

$$= 453.125 \text{ mm}$$

$$1.3M_1/V_u = 545.80 \text{ mm}$$

(> L_d , also, no anchorage required)

OK.

7.3 Design of Beam

Design Procedure of beam

Beam is a flexural member and supports the imposed load. It carries load by bending action. The beam may be rectangle, L and T section consisting of singly and doubly reinforcement.

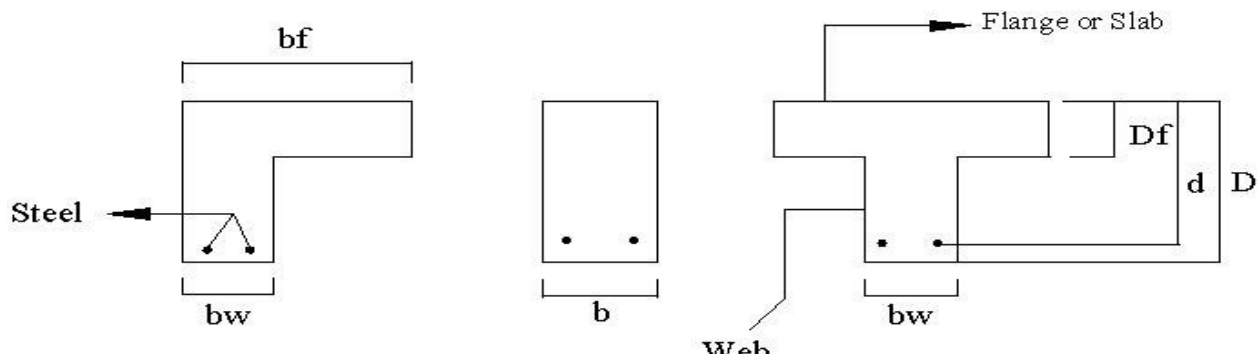

Figure 14: L, Rectangular and T Beam

Design of beams requires determination of the cross-sectional dimensions and reinforcement details to satisfy both serviceability and strength requirements. The serviceability requirement for deflection is controlled by effective span to effective depth ratio. Generally, the depth of the beam is large and governed by the strength requirement. The spacing of reinforcement controls the serviceability requirement for crack. In beams, spacing of reinforcement bars are small and governed by the minimum spacing requirement than maximum spacing for crack control. The reinforcements are provided to satisfy strength requirements. The detailing of longitudinal and transverse bars should satisfy the bending, shear and bond requirements. The bending moment and shear are determined from the analysis generally based on the elastic theory.

Beams are designed for the worst condition. So, the maximum values from the combination have been used for the design.

here are two types of reinforced concrete beams in our case:

- a. Singly Reinforced Beams
- b. Doubly Reinforced Beams

Singly Reinforced Beams:

In singly reinforced simply supported beams, reinforcing steel bars are placed near the bottom of the beams, which is the position where they are the most effective in resisting the tensile stresses. In singly reinforced cantilever beams, reinforcing bars are placed near the top of the beam for the reason.

If $M_u < M_{u1}$, then it is singly reinforced section and the area of steel A_{st} is determined by:

$$A_{st} = \frac{M_{u,lim}}{0.87 * f_y * (d - 0.42 * x_{u,lim})}$$

Detail Design of Beam

Building 1:

Primary Beam (A2-B2)

Concrete Grade = 25MPa

Steel Grade = 30MPa

1. Known Data

Overall depth of beam (D) = 650mm

Width of Beam (B) = 350mm

Effective cover = 42.5mm

Effective depth (d) = 607.5mm

2. Check for member size

Width of beam (B) = 350mm > 200mm (IS 13920:2016 Clause 6.1.2)

Depth of beam (D) = 650mm

B/D = 350/650 = 0.538 > 0.3 (IS 13920:2016 Clause 6.1.1)

Hence, ok.

Clear Length (L) = 6.5 – 2*0.325 = 5.85m

L/D = 5.85/0.65 = 9 > 4 (IS 13920:2016 Clause 6.1.3)

OK

3. Checking for limiting longitudinal reinforcement

$$A_{st,min} = 0.24 * \frac{\sqrt{f_{ck}}}{f_y} * B * D \quad (\text{IS 13920:2016 Clause 6.2.1b})$$

$$= 0.24 * \frac{\sqrt{30}}{500} * 350 * 607.5 = 559 \text{ mm}^2$$

$$A_{st,max} = 0.025BD$$

$$= 5687.5 \text{ mm}^2$$

4. Design for flexure

$$M_{u,lim} = 0.1336 f_{ck} * b * d^2$$

$$M_{u,lim} = 0.1336 * 30 * 350 * 607.5^2 = 517.7 \text{ KNm}$$

A. At the left end

For Hogging (Negative) moment:

Hogging moment (M_u) = -475.56 KNm

Torsional moment = 0.13

Here, $M_u < M_{u,lim}$, so the design is for a singly reinforced section.

For $A_{st,req}$:

$$M_{ul} = 0.87 * f_y * A_{st,req} * \left(d - \frac{f_y * A_{st,req}}{f_{ck} * b} \right)$$

Solving,

$$A_{st,req} = 2168 \text{ mm}^2$$

The area of steel in compression must be at least 50% of the Area of steel in tension

From Sagging moment, $A_{st,req} = 654 \text{ mm}^2$

So, $A_{st,req} = 2168 \text{ mm}^2$

Providing 5#25mm rebars

$$A_{st,provided} = 2454 \text{ mm}^2$$

For Sagging (Positive) moment:

Sagging moment (M_u) = 310.6 KNm

Torsional moment = 0.2

Here, $M_u < M_{u,lim}$, so the design is for a singly reinforced section.

For $A_{st,req}$:

$$M_{ul} = 0.87 * f_y * A_{st,req} * \left(d - \frac{f_y * A_{st,req}}{f_{ck} * b} \right)$$

Solving,

$$A_{st,req} = 1309.8 \text{ mm}^2$$

Area of steel in compression must be at least 50% of Area of steel in tension

From Sagging moment, $A_{st,req} = 1136 \text{ mm}^2$

So, $A_{st,req} = 1309.8 \text{ mm}^2$

Providing 3#25mm rebars

$$A_{st,provided} = 1472 \text{ mm}^2$$

B. For middle part

For Hogging (Negative) moment:

Hogging moment (M_u) = 117.54 KNm

Torsional moment = 0.11

Here, $M_u < M_{u,lim}$, so the design is for singly reinforced section.

For $A_{st,req}$:

$$M_{ul} = 0.87 * f_y * A_{st,req} * (d - \frac{f_y * A_{st,req}}{f_{ck} * b})$$

Solving,

$$A_{st,req} = 461.47 \text{ mm}^2$$

Area of steel in compression must be at least 50% of Area of steel in tension

From Sagging moment, $A_{st,req} = 330.5 \text{ mm}^2$

So, $A_{st,req} = 559 \text{ mm}^2$ (from minimum area criteria)

Providing 2#25mm rebars

$$A_{st,provided} = 981 \text{ mm}^2$$

For Sagging (Positive) moment:

Sagging moment (M_u) = 661.35 KNm

Torsional moment = 0.17

Here, $M_u < M_{u,lim}$, so the design is for a singly reinforced section.

For $A_{st,req}$:

$$M_{ul} = 0.87 * f_y * A_{st,req} * (d - \frac{f_y * A_{st,req}}{f_{ck} * b})$$

Solving,

$$A_{st,req} = 661.35 \text{ mm}^2$$

Area of steel in compression must be at least 50% of Area of steel in tension

From Sagging moment, $A_{st,req} = 230.5 \text{ mm}^2$

So, $A_{st,req} = 661.35 \text{ mm}^2$

Providing 2#25mm rebars

$$A_{st,provided} = 981 \text{ mm}^2$$

C. At the right end

For Hogging (Negative) moment:

Hogging moment (M_u) = 452.78 KNm

Torsional moment = 0.14

Here, $M_u < M_{u,lim}$, so the design is for singly reinforced section.

For $A_{st,req}$:

$$M_{ul} = 0.87 * f_y * A_{st,req} * (d - \frac{f_y * A_{st,req}}{f_{ck} * b})$$

Solving,

$$A_{st,req} = 2039.3 \text{ mm}^2$$

Area of steel in compression must be at least 50% of Area of steel in tension

From Sagging moment, $A_{st,req} = 632 \text{ mm}^2$

So, $A_{st,req} = 2039.3 \text{ mm}^2$

Providing 5#25mm rebars

$$A_{st,provided} = 2454 \text{ mm}^2$$

For Sagging (Positive) moment:

Sagging moment (M_u) = 301.86 KNm

Torsional moment = 0.16

Here, $M_u < M_{u,lim}$, so the design is for a singly reinforced section.

For $A_{st,req}$:

$$M_{ul} = 0.87 * f_y * A_{st,req} * (d - \frac{f_y * A_{st,req}}{f_{ck} * b})$$

Solving,

$$A_{st,req} = 1268.4 \text{ mm}^2$$

Area of steel in compression must be at least 50% of Area of steel in tension

From Sagging moment, $A_{st,req} = 1017 \text{ mm}^2$

So, $A_{st,req} = 1268.4 \text{ mm}^2$

Providing 3#25mm rebars

$$A_{st,provided} = 1472 \text{ mm}^2$$

Table 21: Summary of Flexural Design of Beam

Summary of Flexural Design of Beam			
	Moment (kNm)		
	Left	Mid	Right
Hogging Moment	475.56	117.54	452.78

Torsional Moment	0.13	0.11	0.14
A_{st,req}	2168	661.35	2039.3
	Moment (kNm)		
Sagging Moment	310.6	165.71	301.86
Torsional Moment	0.2	0.17	0.16
A_{st,req}	1309.8	559	1268.4

Table 22: Summary of Required Reinforcement of Beam

Summary of required reinforcement			
	Left	Mid	Right
Bottom	1309.8	559	1268.4
Top	2168	661.35	2039.3

Table 23: Summary of Provided Reinforcement for Beam

Summary of Reinforcement Bars			
	Bottom		
	Left	Mid	Right
Bar Diameter	25	25	25
Number	3	2	3
Area	1472.62	981.74	1472.62
Pt	0.69	0.461	0.49
	Top		
	Left	Mid	Right
Bar Diameter	25	25	25
Number	5	2	5
Area	2454.37	981.74	2454.37
Pc	1.15	0.461	1.15

Check for Shear

From analysis results,

Shear force at left end = -209.63 KN

Shear force at mid span = 114 KN

Shear force at right end = 153.31 KN

Shear force due to formation of plastic hinge at both ends:

For sway to right

$$V_{u,a} = V_a^{D+L} - 1.4 * \frac{M_{u,lim}^{AS} + M_{u,lim}^{Bh}}{L_{AB}}$$

$$V_{u,b} = V_b^{D+L} + 1.4 * \frac{M_{u,lim}^{AS} + M_{u,lim}^{Bh}}{L_{AB}}$$

For sway to left

$$V_{u,a} = V_a^{D+L} + 1.4 * \frac{M_{u,lim}^{Ah} + M_{u,lim}^{Bs}}{L_{AB}}$$

$$V_{u,b} = V_b^{D+L} - 1.4 * \frac{M_{u,lim}^{Ah} + M_{u,lim}^{Bs}}{L_{AB}}$$

Where,

$M_{u,lim}^{As}$ = sagging moment of resistance at left end

$M_{u,lim}^{Bh}$ = hogging moment of resistance at left end

$M_{u,lim}^{Ah}$ = hogging moment of resistance at right end

$M_{u,lim}^{Bs}$ = sagging moment of resistance at right end

V_a^{D+L} = Shear at end A, with a partial safety factor of 1.2 on loads

V_b^{D+L} = Shear at end B, with a partial safety factor of 1.2 on loads

From SP16,

$$M_{u,lim}^{Ah} = 344.11 \text{ KNm}$$

$$M_{u,lim}^{Bs} = 523.75 \text{ KNm}$$

$$M_{u,lim}^{As} = 523.75 \text{ KNm}$$

$$M_{u,lim}^{Bh} = 344.11 \text{ KNm}$$

$$V_a^{D+L} = -209.63 \text{ KN}$$

$$V_b^{D+L} = 153.31 \text{ KN}$$

For sway to right

$$V_{u,a} = V_a^{D+L} - 1.4 * \frac{M_{u,lim}^{AS} + M_{u,lim}^{Bh}}{L_{AB}}$$

$$= -209.63 - 1.4 * \frac{523.75 + 344.11}{5.85}$$

$$= -417.32 \text{ KN}$$

$$V_{u,b} = V_b^{D+L} + 1.4 * \frac{M_{u,lim}^{AS} + M_{u,lim}^{Bh}}{L_{AB}}$$

$$= 153.31 + 1.4 * \frac{523.75 + 344.11}{5.85}$$

$$= 361 \text{ KN}$$

Similarly for sway to left

$$V_{u,a} = -1.94 \text{ KN}$$

$$V_{u,b} = -54.38 \text{ KN}$$

The design shear force to be resisted is taken as the maximum of shear force obtained from analysis and shear force obtained due to the formation of plastic hinges at both ends of the beam plus the factored load on span.

Design shear force:

$$\text{At left end} = -417.32 \text{ KN}$$

$$\text{At mid-span} = 114 \text{ KN}$$

$$\text{At right end} = 361 \text{ KN}$$

i. At left end

$$\text{Tensile steel provided} = 1472.62 \text{ mm}^2$$

$$\text{Percentage of steel} = 0.69\%$$

$$\tau_c = 0.57 \text{ N/mm}^2$$

$$\tau_v = 1.96 \text{ N/mm}^2 (> \tau_c)$$

Thus, shear reinforcement is designed as:

$$V_{us} = V_u - \tau_c * bd$$

$$= 296.12 \text{ KN}$$

$$A_{sv} = \frac{v_u s_v}{2.5 d_1 (0.87 f_y)}$$

Using 10mm dia, 2 legged stirrups of Fe415

$$S_v = 116.35 \text{ mm}$$

ii. At mid span

$$\text{Tensile steel provided} = 981.747 \text{ mm}^2$$

$$\text{Percentage of steel} = 0.46\%$$

$$\tau_c = 0.48 \text{ N/mm}^2$$

$$\tau_v = 0.53 \text{ N/mm}^2 (> \tau_c)$$

Thus, shear reinforcement is designed as:

$$V_{us} = V_u - \tau_c * bd$$

$$= 11.93 \text{ KN}$$

$$A_{sv} = \frac{v_u s_v}{2.5 d_1 (0.87 f_y)}$$

Using 10mm dia, 2 legged stirrups of Fe415

$$S_v = 2885.56 \text{ mm}$$

Provide $S_v = 300 \text{ mm}$

iii. At right end

Tensile steel provided = 1472.62 mm^2

Percentage of steel = 0.69%

$$\tau_c = 0.57 \text{ N/mm}^2$$

$$\tau_v = 1.69 \text{ N/mm}^2 (> \tau_c)$$

Thus, shear reinforcement is designed as:

$$V_{us} = V_u - \tau_c * bd$$

$$= 239.8 \text{ KN}$$

$$A_{sv} = \frac{v_u s_v}{2.5 d_1 (0.87 f_y)}$$

Using 10mm dia, 2 legged stirrups of Fe415

$$S_v = 143.67 \text{ mm}$$

Check for spacing

S_v should not exceed the least of:

- i. $X_1 = \text{short dimension of stirrups} = 350 - 2*40 - 2*10/2 = 260\text{mm}$
 $Y_1 = \text{long dimension of stirrups} = 650 - 2*40 - 2*10/2 = 560\text{mm}$
- ii. 300mm
- iii. $(x_1 + y_1) / 4 = 205\text{mm}$

The spacing of stirrups as confining reinforcement over a length of $2d = 2*607.5 = 1215\text{mm}$ shall be least of the following:

- i. $d/4 = 305\text{mm}$
- ii. 8 times the maximum diameter of longitudinal bar = $8*25 = 200\text{mm}$
- iii. 100mm

Provision of shear reinforcement:

At left end: Provide 10mm 2 legged vertical stirrups @ 110mm c/c up to a length of $2d$

At mid span: Provide 10mm 2 legged vertical stirrups @ 300mm c/c

At right end: Provide 10mm 2legged vertical stirrups @ 140mm c/c up to a length of 2d

Check for deflection

$$L/D = \alpha * \beta * \gamma * l * d$$

$$\alpha = 26$$

$$\beta = 1$$

$$\gamma = 2$$

$$L/D = 52$$

Actual L/D = 9.62 (<52) ok

Check for development length

$$L_D = 1.3M_1/V_u + L_0$$

$$L_D = 0.87 f_y \phi / 4\tau_{bd}$$

For M30, $\tau_{bd} = 1.5 * 1.6 = 2.4$

$$L_D = 1132.8125\text{mm}$$

$$M_1 = 344.23 \text{ kNm}$$

$$V_u = 296.12 \text{ kN}$$

$$\text{Maximum } L_D = 1.3 M_1/V = 1511.22\text{mm} (>L_d, \text{ ok})$$

Primary Beam (B2-C2)

General Information

Table 24: General Information of Beam B2-C2

Concrete Grade (fck)	Strength of steel (fy)	Width of Beam (B)	Depth of beam (D)	Beam Length (L)	Effective cover
30 N/mm ²	500 N/mm ²	350mm	650mm	6.5m	30 mm
Bar Diameter	Effective depth	d'	B/D	L/D ratio	Remarks
25mm	607.5 mm	42.5 mm	0.538 (ok)	10 (ok)	IS 13920:2016 clause 6.1.1 and 6.1.3

Maximum reinforcement	Minimum reinforcement	Limiting moment	Remarks
5687.5 mm ²	559 mm ²	517.7 KNm	IS 13920:206 Clause 6.2.1 and 6.2.2

Table 25: Reinforcement Requirement for Beam B2-C2

	Left top	Left bottom	Centre top	Centre bottom	Right top	Right bottom
Mu (KNm)	-431.48	312.5	-110.08	140.53	-454.34	300
Ast, req	1922.47	1318	431.12	556.08	2048.06	1259.6
The area of steel in compression must be at least 50% of area of steel in tension. Also, the area must be greater than minimum area.						
Ast, req (mm²)	1922.47	1318	559	559	2048.06	1259.6

Table 26: Provided Reinforcement for Beam B2-C2

Summary of Reinforcement Bars			
	Bottom		
	Left	Mid	Right
Bar Diameter	25	25	25
Number	3	2	3
Area	1472.62	981.747	1472.62
Pt	0.69	0.461	0.69
	Top		
	Left	Mid	Right
Bar Diameter	25	25	25

Number	5	2	5
Area	2454.36	981.747	2454.36
Pc	1.15	0.461	1.15

Design for Shear

V_a^{D+L}	V_m	V_b^{D+L}	
-133 KN	104.23 KN	147.73 KN	V_a^{D+L} (Shear due to plastic hinge)

Design Shear Force:

At left end	At mid-span	At right end
-340.69 KN	104.23 KN	355.42 KN

Provision of shear reinforcement:

At left end: Provide 10mm 2 legged vertical stirrups @ 150mm c/c up to a length of 2d

At mid span: Provide 10mm 2 legged vertical stirrups @ 300mm c/c

At right end: Provide 10mm 2legged vertical stirrups @ 1450mm c/c up to a length of 2d

Primary Beam (C2-D2)

General Information

Table 27: General Information of Beam C2-D2

Concrete Grade (fck)	Strength of steel (fy)	Width of Beam (B)	Depth of beam (D)	Beam Length (L)	Effective cover
30 N/mm ²	500 N/mm ²	350mm	650mm	6.5m	30 mm
Bar Diameter	Effective depth	d'	B/D	L/D ratio	Remarks
25mm	607.5 mm	42.5 mm	0.538 (ok)	10 ok	IS 13920:2016 clause 6.1.1 and 6.1.3
Maximum reinforcement	Minimum reinforcement	Limiting moment	Remarks		
5687.5 mm ²	559 mm ²	517.7 KNm	IS 13920:206 Clause 6.2.1 and 6.2.2		

Table 28: Required Reinforcement for Beam C2-D2

	Left bottom	Left top	Centre bottom	Centre top	Right bottom	Right top
Mu (KNm)	314.84	-437.2	165.41	-117.4	293.92	-507.21
Ast, req	1330.05	1953.6	660.08	460.9	1231.01	2353.52
The area of steel in compression must be at least 50% of area of steel in tension. Also, the area must be greater than minimum area.						
Ast, req (mm²)	1330.05	1953.6	660.08	559	1231.01	2353.52

Table 29: Provided Reinforcement for Beam C2-D2

Summary of Reinforcement Bars			
	Bottom		
	Left	Mid	Right
Bar Diameter	25	25	25
Number	3	2	3
Area	1472.62	981.747	1472.62
Pt	0.69	0.461	0.69
	Top		
	Left	Mid	Right
Bar Diameter	25	25	25
Number	5	2	5
Area	2454.36	981.747	2454.36
Pc	1.15	0.461	1.15

Design for Shear

V_a^{D+L}	V_m	V_b^{D+L}	
-138.14 KN	110.8 KN	236.05 KN	V_a^{D+L} (Shear due to plastic hinge)

Table 30: Sway Force Calculation for Beam C2-D2

$M_{u,lim}^{Ah}$	344.11 KNm	Sagging moment of resistance at left end
$M_{u,lim}^{As}$	523.75 KNm	Hogging moment of resistance at left end
$M_{u,lim}^{Bh}$	344.11 KNm	Sagging moment of resistance at right end
$M_{u,lim}^{Bs}$	523.75 KNm	Hogging moment of resistance at right end
$V_{u,a} = V_a^{D+L} - 1.4 * \frac{M_{u,lim}^{AS} + M_{u,lim}^{Bh}}{L_{AB}}$		Sway to right
$V_{u,b} = V_b^{D+L} + 1.4 * \frac{M_{u,lim}^{AS} + M_{u,lim}^{Bh}}{L_{AB}}$		Sway to right
$V_{u,a} = V_a^{D+L} + 1.4 * \frac{M_{u,lim}^{Ah} + M_{u,lim}^{Bs}}{L_{AB}}$		Sway to left
$V_{u,b} = V_b^{D+L} - 1.4 * \frac{M_{u,lim}^{Ah} + M_{u,lim}^{Bs}}{L_{AB}}$		Sway to left

Design Shear Force:

At left end	At mid-span	At right end
-345.03 KN	110.8 KN	443.74 KN

Provision of shear reinforcement:

At left end: Provide 10mm 2 legged vertical stirrups @ 150mm c/c up to a length of 2d

At mid span: Provide 10mm 2 legged vertical stirrups @ 300mm c/c

At right end: Provide 10mm 2legged vertical stirrups @ 100mm c/c up to a length of 2d

Building 2:

Primary Beam (A2-B2)

General Information

Table 31: General Information of Beam A2-B2

Concrete Grade (fck)	Strength of steel (fy)	Width of Beam (B)	Depth of beam (D)	Beam Length (L)	Effective cover
30 N/mm ²	500 N/mm ²	350mm	650mm	4 m	30 mm
Bar Diameter	Effective depth	d'	B/D	L/D ratio	Remarks
25mm	607.5 mm	42.5 mm	0.538 (ok)	6.15 (ok)	IS 13920:2016 clause 6.1.1 and 6.1.3
Maximum reinforcement	Minimum reinforcement	Limiting moment		Remarks	
5687.5 mm ²	559 mm ²	517.7 KNm		IS 13920:206 Clause 6.2.1 and 6.2.2	

Table 32: Required Reinforcement for Beam A2-B2

	Left bottom	Left top	Centre bottom	Centre top	Right bottom	Right top
Mu (KNm)	331.8596	-437.745	86.7148	-62.6015	345.3804	-374.1932
Ast, req	1412	1957	337	241	1478	1622
The area of steel in compression must be at least 50% of area of steel in tension. Also, the area must be greater than minimum area.						
Ast, req (mm²)	1412	1957	559	559	1478	1622

Table 33: Provided Reinforcement for Beam A2-B2

Summary of Reinforcement Bars			
	Bottom		
	Left	Mid	Right
Bar Diameter	25	25	25
Number	3	2	4
Area	1472.62	981.74	1963.49
Pt	0.69	0.461	0.92
	Top		
	Left	Mid	Right
Bar Diameter	25	25	25
Number	4	2	4
Area	1963.49	981.74	1963.49
Pc	0.92	0.461	0.92

Design for Shear

V_a^{D+L}	V_m	V_b^{D+L}	
-80.45 KN	-164.66 KN	41.76 KN	V_a^{D+L} (Shear due to plastic hinge)

Table 34: Shear Force From Sway Condition for Beam A2-B2

$M_{u,lim}^{Ah}$	438.92 KNm	Hogging moment of resistance at left end
$M_{u,lim}^{As}$	344.23 KNm	Sagging moment of resistance at left end
$M_{u,lim}^{Bh}$	438.92 KNm	Hogging moment of resistance at right end

$M_{u,lim}^{Bs}$	438.92 KNm	Sagging moment of resistance at right end
$V_{u,a} = V_a^{D+L} - 1.4 * \frac{M_{u,lim}^{AS} + M_{u,lim}^{Bh}}{L_{AB}}$		Sway to right
$V_{u,b} = V_b^{D+L} + 1.4 * \frac{M_{u,lim}^{AS} + M_{u,lim}^{Bh}}{L_{AB}}$		Sway to right
$V_{u,a} = V_a^{D+L} + 1.4 * \frac{M_{u,lim}^{Ah} + M_{u,lim}^{Bs}}{L_{AB}}$		Sway to left

Design Shear Force:

At left end	At mid-span	At right end
-447.308 KN	-164.66 KN	408.62 KN

Provision of shear reinforcement:

At left end: Provide 10mm 2 legged vertical stirrups @ 100mm c/c up to a length of 2d

At mid span: Provide 10mm 2 legged vertical stirrups @ 300mm c/c

At right end: Provide 10mm 2legged vertical stirrups @ 125 mm c/c up to a length of 2d

Primary Beam (B2-C2)

General Information

Table 35: General Information of Beam B2-C2

Concrete Grade (fck)	Strength of steel (fy)	Width of Beam (B)	Depth of beam (D)	Beam Length (L)	Effective cover
30 N/mm ²	500 N/mm ²	350mm	650mm	4.5 m	30 mm
Bar Diameter	Effective depth	d'	B/D	L/D ratio	Remarks
25mm	607.5 mm	42.5 mm	0.538 (ok)	6.92 (ok)	IS 13920:2016 clause 6.1.1 and 6.1.3
Maximum reinforcement	Minimum reinforcement	Limiting moment	Remarks		

5687.5 mm ²	559 mm ²	517.7 KNm	IS 13920:206
			Clause 6.2.1 and 6.2.2

Table 36: Reinforcement Required for Beam B2-C2

	Left bottom	Left top	Centre bottom	Centre top	Right bottom	Right top
Mu (KNm)	238.85	-310.97	52.76	-43.16	230.91	-310.25
Ast, req	979	1312	203	165	944	1308
The area of steel in compression must be at least 50% of area of steel in tension. Also, the area must be greater than minimum area.						
Ast, req (mm²)	979	1312	561.33	561.33	944	1308

Table 37: Provided Reinforcement for Beam B2-C2

Summary of Reinforcement Bars			
	Bottom		
	Left	Mid	Right
Bar Diameter	25	25	25
Number	2	2	2
Area	981.74	981.74	981.74
Pt	0.69	0.461	0.69
	Top		
	Left	Mid	Right
Bar Diameter	25	25	25

Number	3	2	3
Area	1472.62	981.74	1472.62
Pc	0.69	0.461	0.69

Design for Shear

V_a^{D+L}	V_m	V_b^{D+L}	
-35.28 KN	-76.285 KN	33.305 KN	V_a^{D+L} (Shear due to plastic hinge)

Table 38: Shear Force From Sway Condition for Beam B2-C2

$M_{u,lim}^{Ah}$	344.23 KNm	Hogging moment of resistance at left end
$M_{u,lim}^{As}$	239.47 KNm	Sagging moment of resistance at left end
$M_{u,lim}^{Bh}$	344.23 KNm	Hogging moment of resistance at right end
$M_{u,lim}^{Bs}$	239.47 KNm	Sagging moment of resistance at right end
$V_{u,a} = V_a^{D+L} - 1.4 * \frac{M_{u,lim}^{AS} + M_{u,lim}^{Bh}}{L_{AB}}$		Sway to right
$V_{u,b} = V_b^{D+L} + 1.4 * \frac{M_{u,lim}^{AS} + M_{u,lim}^{Bh}}{L_{AB}}$		Sway to right
$V_{u,a} = V_a^{D+L} + 1.4 * \frac{M_{u,lim}^{Ah} + M_{u,lim}^{Bs}}{L_{AB}}$		Sway to left
$V_{u,b} = V_b^{D+L} - 1.4 * \frac{M_{u,lim}^{Ah} + M_{u,lim}^{Bs}}{L_{AB}}$		Sway to left

Design Shear Force:

At left end	At mid-span	At right end
-269.346 KN	-76.285 KN	267.371 KN

Provision of shear reinforcement:

At left end: Provide 10mm 2 legged vertical stirrups @ 200mm c/c up to a length of 2d

At mid span: Provide 10mm 2 legged vertical stirrups @ 300mm c/c

At right end: Provide 10mm 2legged vertical stirrups @ 200mm c/c up to a length of 2d

Primary Beam (C2-D2)

General Information

Table 39: General Information of Beam C2-D2

Concrete Grade (fck)	Strength of steel (fy)	Width of Beam (B)	Depth of beam (D)	Beam Length (L)	Effective cover
30 N/mm ²	500 N/mm ²	350mm	650mm	5.7 m	30 mm
Bar Diameter	Effective depth	d'	B/D	L/D ratio	Remarks
25mm	607.5 mm	42.5 mm	0.538 (ok)	8.77 (ok)	IS 13920:2016 clause 6.1.1 and 6.1.3
Maximum reinforcement	Minimum reinforcement	Limiting moment	Remarks		
5687.5 mm ²	559 mm ²	517.7 KNm	IS 13920:206 Clause 6.2.1 and 6.2.2		

Table 40: Required Reinforcement for Beam C2-D2

	Left bottom	Left top	Centre bottom	Centre top	Right bottom	Right top
Mu (KNm)	241.88	-358.48	94.93	-48.1678	219.69	-348.13
Ast, req	993	1543	370	185	894	1492
The area of steel in compression must be at least 50% of area of steel in tension. Also, the area must be greater than minimum area.						

Ast, req (mm²)	993	1543	559	559	894	1492
Summary of Reinforcement Bars						
Bottom						
	Left	Mid	Right			
Bar Diameter	25	25	25			
Number	3	2	3			
Area	1472.62	981.74	1472.62			
Pt	0.69	0.461	0.69			
Top						
	Left	Mid	Right			
Bar Diameter	25	25	25			
Number	4	2	4			
Area	1963.49	981.74	1963.49			
Pc	0.923	0.461	0.923			

Design for Shear

V_a^{D+L}	V_m	V_b^{D+L}	
-86.9078 KN	70.56 KN	83.87 KN	V_a^{D+L} (Shear due to plastic hinge)

Table 41: Shear Force From Sway Condition for Beam C2-D2

$M_{u,lim}^{Ah}$	439.01 KNm	Hogging moment of resistance at left end
$M_{u,lim}^{As}$	344.23 KNm	Sagging moment of resistance at left end
$M_{u,lim}^{Bh}$	439.01 KNm	Hogging moment of resistance at right end

$M_{u,lim}^{Bs}$	344.23 KNm	Sagging moment of resistance at right end
$V_{u,a} = V_a^{D+L} - 1.4 * \frac{M_{u,lim}^{AS} + M_{u,lim}^{Bh}}{L_{AB}}$		Sway to right
$V_{u,b} = V_b^{D+L} + 1.4 * \frac{M_{u,lim}^{AS} + M_{u,lim}^{Bh}}{L_{AB}}$		Sway to right
$V_{u,a} = V_a^{D+L} + 1.4 * \frac{M_{u,lim}^{Ah} + M_{u,lim}^{Bs}}{L_{AB}}$		Sway to left
$V_{u,b} = V_b^{D+L} - 1.4 * \frac{M_{u,lim}^{Ah} + M_{u,lim}^{Bs}}{L_{AB}}$		Sway to left

Design Shear Force:

At left end	At mid-span	At right end
-304.06 KN	70.56 KN	301.02 KN

Provision of shear reinforcement:

At left end: Provide 10mm 2 legged vertical stirrups @ 180mm c/c up to a length of 2d

At mid span: Provide 10mm 2 legged vertical stirrups @ 300mm c/c

At right end: Provide 10mm 2legged vertical stirrups @ 180mm c/c up to a length of 2d

Primary Beam (D2-E2)

General Information

Table 42: General Information of Beam D2-E2

Concrete Grade (fck)	Strength of steel (fy)	Width of Beam (B)	Depth of beam (D)	Beam Length (L)	Effective cover
30 N/mm ²	500 N/mm ²	350mm	650mm	6 m	30 mm
Bar Diameter	Effective depth	d'	B/D	L/D ratio	Remarks
25mm	607.5 mm	42.5 mm	0.538 (ok)	8.77 (ok)	IS 13920:2016 clause 6.1.1 and 6.1.3

Maximum reinforcement	Minimum reinforcement	Limiting moment	Remarks
5687.5 mm ²	559 mm ²	517.7 KNm	IS 13920:206 Clause 6.2.1 and 6.2.2

Table 43: Required Reinforcement For Beam D2-E2

	Left bottom	Left top	Centre bottom	Centre top	Right bottom	Right top
Mu (KNm)	188.12	-338.95	104.61	-47.66	174.78	-391.2
Ast, req	757	1447	409	183	700	1709
The area of steel in compression must be at least 50% of area of steel in tension. Also, the area must be greater than minimum area.						
Ast, req (mm²)	757	1447	559	559	854.5	1709

Table 44: Provided Reinforcement for Beam D2-E2

Summary of Reinforcement Bars			
Bottom			
	Left	Mid	Right
Bar Diameter	25	25	25
Number	2	2	2
Area	981.74	981.74	981.74
Pt	0.46	0.461	0.46
Top			
	Left	Mid	Right
Bar Diameter	25	25	25

Number	4	2	4
Area	1963.49	981.74	1963
Pc	0.92	0.461	0.92

Design for Shear

Table 45: Shear Force Calculation for Beam D2-E2

V_a^{D+L}	V_m	V_b^{D+L}	
-115.43 KN	80.91 KN	157.1 KN	V_a^{D+L} (Shear due to plastic hinge)
$M_{u,lim}^{Ah}$		439.02 KNm	Hogging moment of resistance at left end
$M_{u,lim}^{As}$		239.47 KNm	Sagging moment of resistance at left end
$M_{u,lim}^{Bh}$		439.02 KNm	Hogging moment of resistance at right end
$M_{u,lim}^{Bs}$		239.47 KNm	Sagging moment of resistance at right end
$V_{u,a} = V_a^{D+L} - 1.4 * \frac{M_{u,lim}^{AS} + M_{u,lim}^{Bh}}{L_{AB}}$			Sway to right
$V_{u,b} = V_b^{D+L} + 1.4 * \frac{M_{u,lim}^{AS} + M_{u,lim}^{Bh}}{L_{AB}}$			Sway to right
$V_{u,a} = V_a^{D+L} + 1.4 * \frac{M_{u,lim}^{Ah} + M_{u,lim}^{Bs}}{L_{AB}}$			Sway to left
$V_{u,b} = V_b^{D+L} - 1.4 * \frac{M_{u,lim}^{Ah} + M_{u,lim}^{Bs}}{L_{AB}}$			Sway to left

Design Shear Force:

At left end	At mid-span	At right end
-292.98 KN	80.91 KN	334.65 KN

Provision of shear reinforcement:

At left end: Provide 10mm 2 legged vertical stirrups @ 175 mm c/c up to a length of 2d

At mid span: Provide 10mm 2 legged vertical stirrups @ 300 mm c/c

At right end: Provide 10mm 2legged vertical stirrups @ 145 mm c/c up to a length of 2d

7.4 Design of Columns

Columns are the vertical members that transfer axial as well as lateral loads and moments from the upper structure. Columns support the beams and slabs, and transfer the forces from beams to the foundation.

Depending upon the slenderness ratio, column is divided into short column (*slenderness ratio* ≤ 12) and long column (*slenderness ratio* > 12) which fails predominantly by compression and buckling respectively. The slenderness ratio of a column is given by the ratio of effective length to dimension of the column. Based on loading criteria, the columns can be axially loaded, uniaxially loaded or biaxially loaded columns, which is classified according to the eccentricity ratio of the column in two orthogonal directions.

The following steps are involved in the design of columns:

1. Preliminary Design
2. Slenderness Check
3. Check for Eccentricity
4. Design of Longitudinal Reinforcement
5. Design of Lateral Reinforcement

The sample calculation for the manual design of a typical column is shown below in the table:

Building 1:

Table 46: Design of Column for Building 1

Design steps	Reference	Calculations	Output/remarks
1		Member dimensions Width=650mm Length=650mm	D= 650mm B= 650mm

		<p>Height of floor=3.6m</p> <p>Unsupported length=3.6-0.65=2.95 m</p> <p>Assume,</p> <p>Clear cover= 40mm</p> <p>$\phi_{max}=25mm$</p> <p>So,</p> <p>Effective cover= $40+25/2$</p> <p style="text-align: center;">= 40+12.5</p> <p style="text-align: center;">= 52.5mm</p>	<p>L= 3.6m</p> <p>d'=52.5mm</p>
2	IS 13920:2016 Cl.7.1	<p>Check for maximum axial stress</p> <p>Maximum factored load=4367.763 KN</p> <p>Maximum stress=$\frac{4367.76*1000}{650*650}$</p> <p style="text-align: center;">=10.33 N/mm²<0.4fck=12N/mm²</p> <p>Since, the maximum stress due to maximum load combination relating to seismic load is under 0.4fck, it is safe under compressive stress.</p>	<p>$\sigma(max)$</p> <p style="text-align: center;">=10.33</p> <p style="text-align: center;"><0.4fck</p>
3	IS13920:2016 Cl 7.1.1 Cl 7.1.2	<p>Check for minimum member size</p> <p>Width of column= 650mm</p> <p>Depth of column = 650mm</p> <p>Minimum dimension = $20 \times d_b$</p> <p style="text-align: center;">=20*25</p> <p style="text-align: center;">= 500mm</p> <p>B/D = 650/650</p> <p style="text-align: center;">=1>0.45(OK)</p>	
4		<p>Check for slenderness</p> <p>$\beta_1=\beta_2=\frac{\sum K_c}{\sum K_c+\sum K_b}$</p>	

	<p>ETABS</p> <p>ANNEX E IS456</p> <p>IS 456:2000</p> <p>Cl 25.1.2</p>	<p>MOI of column = 0.01041 m³</p> <p>$K_c = I_c / L_c$</p> <p>= (0.01041/2.95)</p> <p>= 0.00352</p> <p>For x direction:</p> <p>MOI of beam = 0.008 m³</p> <p>$K_b = 1/2 * I_b / L_b$</p> <p>= (0.008/6.5)</p> <p>= 0.000616</p> <p>$\beta_1 = \beta_2 = \frac{2 * 0.00352}{2 * 0.00352 + 0.000215}$</p> <p>= 0.97</p> <p>For y direction:</p> <p>MOI of beam = 0.008 m³</p> <p>$K_b = I_b / L_b$</p> <p>= (0.008/4.5*2) + (0.008/5.5*2)</p> <p>= 0.000565</p> <p>$\beta_1 = \beta_2 = \frac{2 * 0.00352}{2 * 0.00352 + 0.000565}$</p> <p>= 0.92</p> <p>From ETABS,</p> <p>Q value = 0.028</p> <p>Since the Q value is less than 0.4, the frame structure is taken as frame restraint against sway</p> <p>$K_x = 0.97$</p> <p>$K_y = 0.92$</p> <p>For x- direction,</p> <p>$L_{eff} = 0.97 * 2.95 = 2.8615m$</p> <p>$L_{eff} / D = 2.8614 / 0.65$</p> <p>= 4.4 < 12</p> <p>For y- direction</p> <p>$L_{eff} = 0.92 * 2.95 = 2.714m$</p>	
--	---	--	--

		$L_{eff}/B = 2.714/0.65$ $= 4.17 < 12$ So, the column is treated as a short column in both directions.	
5	IS 456:2000 Cl. 25.5.3.1 (a)	Limiting longitudinal reinforcement Min. Reinforcement = 0.8% of bd $= 0.008 * 650 * 650$ $= 3380 \text{mm}^2$ Max reinforcement = 6% of bd $= 0.06 * 650 * 650$ $= 25350 \text{mm}^2$	
6	ETABS	$P = 4367.76 \text{ KN}$ $M_{u2} = 813.29 \text{ KN-m}$ $M_{u3} = 110.32 \text{ KN-m}$ $V_u = 420.43 \text{ KN}$ Shear force due to plastic hinge in beam: Sagging moment capacity of beam, $M_s = 379.26 \text{ KN-m}$ Hogging moment capacity of beam, $M_h = 208.11 \text{ KN-m}$ Height of story, $h_s = 3.6 \text{ m}$ So shear force due to plastic failure in beam $= \frac{M_s + M_h}{h_s} * 1.4$ we get, $V_u = 411.86 \text{ KN}$ (Detailed calculation is shown at the end) So design shear force in the column is 420.43 KN.	

7	IS 456:2000 Cl 25.4	<p>Check for eccentricity</p> $e_{\min} = \frac{l}{500} + \frac{D}{30}$ $= (3000/500) + (650/30)$ $= 27.67\text{mm} > 20\text{mm}$ <p>Actual eccentricity(e_{act})</p> $e_{\text{actual, x}} = M_{u3}/P$ $= 110.32 \cdot 1000 / 4367.76$ $= 25.25 \text{ mm}$ $e_{\text{actual, y}} = M_{u2}/P$ $= 813.29 \cdot 1000 / 4367.76$ $= 186.2 \text{ mm}$ <p>Since actual eccentricity in Y directions is more than 0.05D, the column shall be treated as a uni-axially loaded column.</p>	$E_{\text{act}} > 0.05D$
8	From SP 16, Chart 48	$M_{u,\text{design}} = 813.29 \text{ KNm}$ $P_u = 4367.76 \text{ KN}$ $d' = 52.5\text{mm}$ $d/D = 0.081$ $P_u/f_{ck} \cdot bd = 0.346$ $M_u/f_{ck} \cdot bd^2 = 0.098$ Assuming reinforcement is distributed equally in four sides $P/f_{ck} = 0.055$ $P\% = 0.055 \cdot 30$ $= 1.65\%$	
9		Provided reinforcement $A_{st} \text{ required} = 6971.25\text{mm}^2$	

		Provide 20 reinforcements of 25mm diameter, 6 bars equally on all 4 sides. So, Ast provided = 9817.48 mm ²	9817.48 > Min 9817.48 < Max
10	IS 456:2000 Cl 26.5.3.2.c	Design of lateral ties $\phi_t > 6\text{mm}$ $\phi_t > \frac{25}{4} = 6.25\text{mm}$ So adopt lateral ties of 8mm diameter. Minimum spacing of lateral ties \leq least lateral dimension (650mm) $\leq 16 * \phi = 16 * 25 = 400\text{mm}$ $\leq 300\text{mm}$ So, provide 4 closed rectangular transverse reinforcements at spacing of 200mm center to center.	$\phi_t = 8\text{mm}$ $S_v = 200\text{mm}$
11	IS13920:2016 Cl 8.1	Special confining reinforcements a. Confining zone length l_0 is taken maximum of i. Larger lateral dimension of column i.e., 650mm ii. 1/6 of clear span i.e., 975mm iii. 450mm So provide $l_0 = 1000\text{mm}$ b. Spacing is taken a minimum of i. 1/4th of min lateral dimension of column and beam i.e., 75mm ii. 6 times min. longitudinal diameter i.e., 150mm iii. 100mm	

		<p>So, provide spacing of 75mm in confining region.</p> <p>Spacing check from area consideration</p> <p>$A_{sh} = \text{Maximum of}$</p> $0.18 S_v h \frac{f_{ck}}{f_y} \left(\frac{A_g}{A_k} - 1 \right)$ $0.05 S_v h \frac{f_{ck}}{f_y}$ $= 0.18 * S_v * 142.5 * \frac{30}{500} * \left(\frac{422500}{324900} - 1 \right)$ $= 0.462 S_v$ $= 0.05 * S_v * 142.5 * \frac{30}{500}$ $= 0.4275 S_v$ <p>So,</p> $S_v = 108.79 \text{mm}$ <p>Design of shear reinforcement</p> <p>Area of steel provided = 9817.48 mm²</p> <p>Area of tension steel = 0.5*9817.48</p> $= 4908.74 \text{ mm}^2$ <p>$T_c = 0.692 \text{ N/mm}^2$</p> <p>For columns subjected to axial compression the shear stress should be increased by δ which is given by</p> $\delta = 1 + 3 * P_u / \text{Area} * f_{ck}$ $= 1 + (3 * 4367.76) / 650^2 * 30$ $= 2.03 < 1.5$ <p>So, $T_c = 1.5 * 0.692$</p> $= 1.038 \text{N/mm}^2$ <p>Shear capacity of concrete</p> $= 1.068 * 650 * 650$	
--	--	---	--

		$= 451.23 \text{ KN}$ Provide minimum shear reinforcement $A_{sv} = \pi * 8^2 / 4 * 4$ $= 201.06 \text{ mm}$ $V_{us} = 0.87 * 415 * 201.06 * 597.5 / S_v$ $S_v = 300 \text{ mm}$	
12	IS 456:2000 Cl 26.2.1	Splicing of vertical bars Maximum of 50% bars should be spliced at a section and the clear overlap of the spliced section should be more than development length of the largest bars. $L_d = \frac{0.87 * 500 * 25}{4 * 1.6 * 1.25 * 1.5}$ $= 906.25 \text{ mm}$ Therefore, provide the overlap of 1000mm in spliced section.	

Calculation of shear force due to plastic failure of beam:

Table 47: Calculation of Shear Force in Column in Building 1

Beam	A _{st} (top)	A _{st} (bottom)	MOR _h	MOR _s
Left	2454.36	1472.62	523.75	344.11
Right	0	0	0	0
Up	2454.36	1472.62	523.75	344.11
Down	2454.36	1472.62	523.75	344.11

Sway Direction	V _u (KN)
To right	163.306
To left	248.56
To up	411.86
To down	411.86

Building 2:

Table 48: Design of Column of Building 2

Design steps	Reference	Calculations	Output/remarks
1		<p>Member dimensions</p> <p>Width=650mm</p> <p>Length=650mm</p> <p>Height of floor=3.6m</p> <p>Unsupported length=3.6-0.65=2.95m</p> <p>Assume,</p> <p style="padding-left: 40px;">Clear cover= 40mm</p> <p style="padding-left: 40px;">$\phi_{\max}=25\text{mm}$</p> <p>So,</p> <p style="padding-left: 40px;">Effective cover= $40+25/2$</p> <p style="padding-left: 80px;">= $40+12.5$</p> <p style="padding-left: 80px;">= 52.5mm</p>	<p>D= 650mm</p> <p>B= 650mm</p> <p>L= 3.6m</p> <p>d'=52.5mm</p>
2	IS 13920:2016 Cl.7.1	<p>Check for maximum axial stress</p> <p>Maximum factored load=4360.301KN</p> <p>Maximum stress=$\frac{4360.301*1000}{650*650}$</p> <p style="padding-left: 40px;">=10.31N/mm²<0.4fck=12N/mm²</p> <p>Since, the maximum stress due to maximum load combination relating to seismic load is under 0.4fck, it is safe under compressive stress.</p>	<p>$\sigma(\max)$</p> <p>=10.31</p> <p><0.4fck</p>
3	IS13920:2016 Cl 7.1.1	<p>Check for minimum member size</p> <p>Width of column= 650mm</p> <p>Depth of column = 650mm</p> <p>Minimum dimension = $20x d_b$</p> <p style="padding-left: 40px;">=20*25</p> <p style="padding-left: 40px;">= 500mm</p>	

	CI 7.1.2	B/D = 650/650 =1>0.45(OK)	
4	ETABS ANNEX E IS456	<p>Check for slenderness</p> $\beta_1=\beta_2=\frac{\Sigma Kc}{\Sigma Kc+\Sigma Kb}$ <p>MOI of column = 0.0148 m³</p> $Kc=Ic/Lc$ $= (0.0148/2.95)$ $= 0.00501$ <p>For y direction:</p> <p>MOI of beam = 0.00809 m³</p> $Kb=Ib/Lb$ $= (0.00809/6)$ $= 0.000674$ $\beta_1=\beta_2 = \frac{2*0.00501}{2*0.00501+0.000674}$ $=0.93$ <p>For y direction:</p> <p>MOI of beam = 0.00809 m³</p> $K_b=I_b/L_b$ $= (0.00809/5.7*2) + (0.00809/4.5*2)$ $= 0.00160$ $\beta_1=\beta_2 = \frac{2*0.00501}{2*0.00501+0.00160}$ $= 0.86$ <p>From ETABS, Q value = 0.022 Since Q value is less than 0.4, frame structure is taken as frame restraint against sway</p> $K_x = 0.88$ $K_y = 0.94$	

	IS 456:2000 Cl 25.1.2	<p>For x- direction, $L_{eff} = 0.88 * 2.95 = 2.596m$ $L_{eff}/D = 2.596/0.65$ $= 4 < 12$</p> <p>For y- direction $L_{eff} = 0.94 * 2.95 = 2.77m$ $L_{eff}/B = 2.77/0.65$ $= 4.26 < 12$</p> <p>So, the column is treated as a short column in both directions.</p>	
5	IS 456:2000 Cl. 25.5.3.1 (a)	<p>Limiting longitudinal reinforcement</p> <p>Min. Reinforcement = 0.8% of bd $= 0.008 * 650 * 650$ $= 3380mm^2$</p> <p>Max reinforcement = 6% of bd $= 0.06 * 650 * 650$ $= 25350 mm^2$</p>	
6	ETABS	<p>P= 1243.21 KN $M_{u2} = 209.401 KN-m$ $M_{u3} = 846.84 KN-m$ Shear force due to plastic hinge in beam Sagging moment capacity of beam, Ms $= 379.26 KN-m$ Hogging moment capacity of beam, Mh $= 208.11 KN-m$ Height of story, hs = 3.6m So shear force due to plastic failure in beam $= \frac{M_s + M_h}{H_s} * 1.4$ we get, Vu= 227 KN (Detailed calculation is shown at the end)</p>	

	IS 456:2000 Cl 39.6	<p>So, $M_{ul} = 1071.035 \text{ KN-m}$</p> <p>$A_{sc} = 8450 \text{ mm}^2$</p> <p>$P_{uz} = (0.45 * f_{ck} * 650 * 650) + (0.75 * 500 * 8450)$ $= 8872.5 \text{ KN}$</p> <p>$\frac{Pu}{P_{uz}} = \frac{1243.21}{8872.5} = 0.14$</p> <p>For 0.14, $\alpha = 1$</p> <p>For biaxially loaded column, $\left(\frac{Mu_2}{Mu_1}\right)^\alpha + \left(\frac{Mu_3}{Mu_1}\right)^\alpha$ $= 0.1955 + 0.794$ $= 0.986 < 1 \text{ (OK)}$</p> <p>Hence the column is safe.</p>	<p>$M_{ul} = 1071.035 \text{ kN-m}$</p> <p>$P_{uz} = 8872.5 \text{ KN}$</p>
9		<p>Provided reinforcement</p> <p>$A_{st} \text{ required} = 8450 \text{ mm}^2$</p> <p>Provide 20 reinforcements, 6 bars equally on all 4 sides.</p> <p>So, $A_{st} \text{ provided} = 9817.48 \text{ mm}^2$</p>	<p>$9817.48 > \text{Min}$</p> <p>$9817.48 < \text{Max}$</p>
10	IS 456:2000 Cl 26.5.3.2.c	<p>Design of lateral ties</p> <p>$\phi_t > 6 \text{ mm}$</p> <p>$\phi_t > \frac{25}{4} = 6.25 \text{ mm}$</p> <p>So adopt lateral ties of 8mm diameter.</p> <p>Minimum spacing of lateral ties</p>	<p>$\phi_t = 8 \text{ mm}$</p> <p>$S_v = 200 \text{ mm}$</p>

		We get $S_v = 482.47\text{mm}$	
11	IS13920:2016 Cl 8.1	<p>Special confining reinforcements</p> <p>a. Confining zone length l_0 is taken maximum of</p> <p>i. Larger lateral dimension of column i.e., 650mm</p> <p>ii. 1/6 of clear span i.e., 975mm</p> <p>iii. 450mm</p> <p>So provide $l_0 = 1000\text{mm}$</p> <p>b. Spacing is taken minimum of</p> <p>i. 1/4th of min lateral dimension of column and beam i.e., 75mm</p> <p>ii. 6 times min. longitudinal diameter i.e., 150mm</p> <p>iii. 100mm</p> <p>So, provide spacing of 75mm in confining region.</p> <p>Spacing check from area consideration</p> <p>$A_{sh} = \text{Maximum of}$</p> $0.18 S_v h \frac{f_{ck}}{f_y} \left(\frac{A_g}{A_k} - 1 \right)$ $0.05 S_v h \frac{f_{ck}}{f_y}$ $= 0.18 * 75 * 114 * \frac{30}{500} * \left(\frac{422500}{324900} - 1 \right)$ $= 27.73$ $= 0.05 * 75 * 114 * \frac{30}{500}$ $= 25.65$	

		So, $A_{sh} = 27.73$	
12	IS 456:2000 Cl 26.2.1	Splicing of vertical bars Maximum of 50% bars should be spliced at a section and the clear overlap of the spliced section should be more than development length of the largest bars. $L_d = \frac{0.87 \cdot 500 \cdot 25}{4 \cdot 1.6 \cdot 1.25 \cdot 1.5}$ $= 906.25 \text{mm}$ Therefore, provide the overlap of 1000mm in spliced section.	

Calculation of shear force due to plastic failure of beam:

Table 49: Calculation of Shear Force in Column of Building 2

Beam	(Ast) _{top}	(Ast) _{bottom}	(MOR) _h	(MOR) _s
Left	1472.62	981.74	344.23	239.47
Right	1472.62	981.74	344.23	239.47
Up	0	0	0	0
Down	1472.62	981.74	344.23	239.47
Sway direction		Vu(KN)		
To right		226.99444		
To left		226.99444		
To up		93.127222		
To down		133.86722		

7.5 Design of Staircase

Stairs, along with elevators are the only means of providing access between the adjacent floor of the buildings. Stairs consist of flight and landing. Flight is the inclined slab consisting of risers and treads whereas the landing is the horizontal slab. The design of the flight is similar to a one-way slab.

Generally, the stairs are found to be isolated from the building while modeling the RC buildings but in practice, stairs are built integrally with the structural system of the building. Thus, the elements of the stairs such as flight and landing slabs act as the diagonal braces and attract large lateral forces during an earthquake, thereby incurring great damage. The beam supporting the landing slab of the dog-legged stair will also cause the secondary effect of short column effects, in addition to causing the twist of the building due to stiffness irregularity in the plan, if they are not located centrally. This effect results in enhanced shear demand and thus should be designed accordingly.

In both of our buildings, there is only one type of staircase, the dog-legged staircase, located at the edge of both buildings. In this type of staircase, the landing is supported on landing beams at the middle of each floor level, so, the stairs are designed as longitudinally spanning.

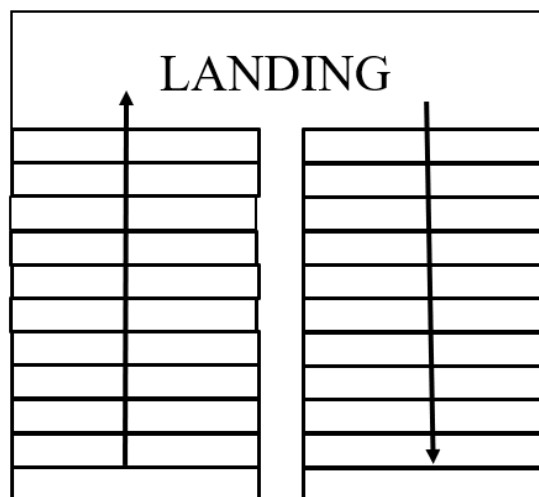

Figure 15: Typical Staircase

Design of Dog-legged staircase:

Building 1:

Table 50: Design Of Staircase of Building 1

Ref.	Steps	Calculation	Output/Remarks
	1	<p>Known data:</p> <ul style="list-style-type: none"> • Floor height=3.6m • Tread width=300mm • Riser height=150mm • Number of risers=2*12=24 • Number of treads=2*11=22 • Length of flight on each floor=3300mm • Width of flight = 1 m • $\cos\theta = \frac{3.3}{(3.3^2 + 1.8^2)}$ = 0.878 <p>Some assumed data:</p> <ul style="list-style-type: none"> • Depth of waist slab be (D) = 175mm • Clear cover (cc) = 25mm • Diameter of bar (ϕ) = 16mm 	<p>3.3 m is the going length.</p> <p>1.8 m is the height of the single flight.</p>
	2 2.1.1	<p>Load Calculation:</p> <p>Load calculation for landing 1</p> <p>Self weight of landing = 0.175×25 = 4.375 kN/m²</p> <p>Imposed load = 3 kN/m²</p>	

	<p>2.1.2</p> <p>2.2</p>	<p>Floor finish = 1 kN/m²</p> <p>Total factored load on landing = 1.5*(4.375+3+1) =12.56 kN/m²</p> <p>Load calculation for landing 2</p> <p>Self weight of landing = 0.175*25 = 4.375 kN/m²</p> <p>Imposed load = 3 kN/m²</p> <p>Floor finish = 1 kN/m²</p> <p>Total factored load on landing = 1.5*(4.375+3+1) =12.56 kN/m²</p> <p>Load calculation for flight</p> <p>Self weight of waist slab = 4.375*(0.335/0.3) = 4.88 kN/m²</p> <p>Self weight of waist steps = $0.5 * \frac{0.15*0.3*25}{0.3}$ =1.875 kN/m²</p> <p>Imposed load = 3 kN/m²</p> <p>Total factored load = 1.5*(4.88+1.875+3) = 14.63 kN/m²</p>	
3		<p>Analysis</p> <p>UDL on landing 1 = 12.56 kN/m²</p> <p>UDL on landing 2 = 12.56 kN/m²</p> <p>UDL on flight = 14.63 kN/m²</p>	<p>AB and CD are landing.</p> <p>BC is flight.</p>

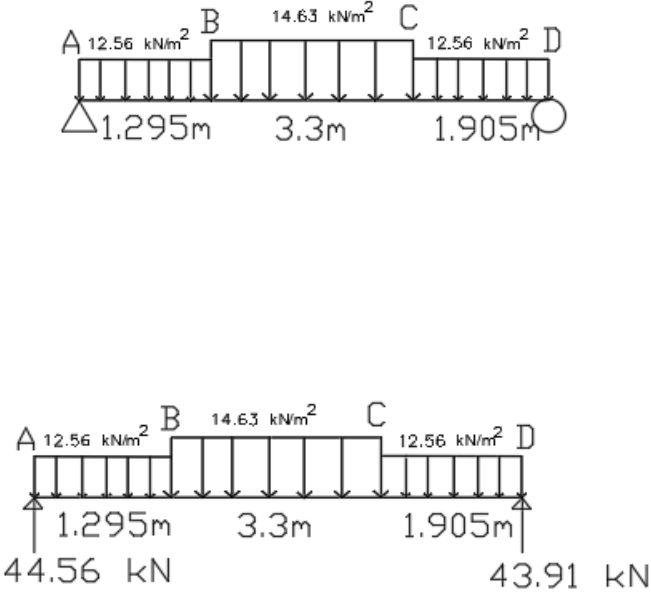
		 <p>The maximum bending moment in flight is at 3.225m from A.</p> <p>Maximum BM $= 44.56 \times 3.225 - 12.56 \times 1.295 \times (1.295/2 + 1.93) - 14.63 \times 1.93 \times 1.93/2$ $= 74.53 \text{ kNm}$</p>	<p>Note: Although the landing and flight is supported in the beam it is not assumed fix support. This is because the torsion in the beam has been released which means beam won't take any moment from landing and flight. So, assuming simply supported will keep us in safer side.</p>
4		<p>Design of flight</p> <p>For effective depth d, $M_{u,lim} = 0.133 \times f_{ck} \times b d^2$</p> $74.53 \times 10^6 = 0.133 \times 30 \times 1000 \times d^2$ <p>On solving,</p> $d = 136.67 \text{ mm} < d_{provided} \text{ (OK)}$	$D_{provided} = 175 \text{ mm}$ $d_{provided} = 175 - 25 - 16/2$ $= 142 \text{ mm}$
5		<p>Determination of main reinforcement:</p>	

		$M_U = 0.87 * f_y * A_{st} * d * \left(1 - \frac{f_y * A_{st}}{f_{ck} * b * d}\right)$ $74.53 * 10^6 = 0.87 * 500 * A_{st} * 142 * \left(1 - \frac{500 * A_{st}}{30 * 1000 * 142}\right)$ $A_{st} = 1455.07 \text{ mm}^2$ <p>Required spacing of 16mm bars, c/c spacing = $1000 * 64 * \pi / 1455.07 = 138.18 \text{ mm}$</p> <p>Provide 16 mm dia. bars @ 135mm c/c</p> $A_{st, \text{ provided}} = 1489.34 \text{ mm}^2$	
6		<p>Development Length Check</p> $L_d = \Phi * f_s / 4 \tau$ $= 725 \text{ mm}$ $M_1 = 41.97 \text{ KNm}$ $V = 44.56 \text{ KN}$ $M_1 / V = 941 \text{ mm}$ <p>So, it is safe in development length</p>	
7		<p>Distribution Reinforcement:</p> $A_{st \text{ min}} = 0.12\% \text{ of } bD$ $= 210 \text{ mm}^2$ <p>Provide 10 mm bars as distribution reinforcement</p> $\text{Spacing} = 1000 * 25 * \pi / 210 = 374 \text{ mm}$ <p>Provide 10 mm dia. bars @ 300 mm c/c.</p>	

Building 2:

Table 51: Design of Staircase of Building 2

Ref.	Steps	Calculation	Output/Remarks
	1	<p>Known data:</p> <ul style="list-style-type: none"> • Floor height=3.6m • Tread width=300mm • Riser height=150mm • Number of risers=2*12=24 • Number of treads=2*11=22 • Length of flight on each floor=3300mm • Width of flight = 1 m • $\cos\theta = \frac{3.3}{(3.3^2 + 1.8^2)}$ = 0.878 <p>Some assumed data:</p> <ul style="list-style-type: none"> • Depth of waist slab be (D) = 175mm • Clear cover (cc) = 25mm • Diameter of bar (ϕ) = 16mm 	<p>3.3 m is the going length.</p> <p>1.8 m is the height of the single flight.</p>

2	<p>Load Calculation:</p> <p>2.1.1 Load calculation for landing 1</p> <p>Self weight of landing = 0.175×25 $= 4.375 \text{ kN/m}^2$</p> <p>Imposed load = 4 kN/m^2</p> <p>Floor finish = 1 kN/m^2</p> <p>Total factored load on landing = $1.5 \times (4.375 + 4 + 1)$ $= 14.06 \text{ kN/m}^2$</p> <p>2.1.2 Load calculation for landing 2</p> <p>Self weight of landing = 0.175×25 $= 4.375 \text{ kN/m}^2$</p> <p>Imposed load = 4 kN/m^2</p> <p>Floor finish = 1 kN/m^2</p> <p>Total factored load on landing = $1.5 \times (4.375 + 4 + 1)$ $= 14.06 \text{ kN/m}^2$</p> <p>2.2 Load calculation for flight</p> <p>Self weight of waist slab = $4.375 \times (0.335 / 0.3)$ $= 4.88 \text{ kN/m}^2$</p> <p>Self weight of waist steps = $0.5 \times \frac{0.15 \times 0.3 \times 25}{0.3}$ $= 1.875 \text{ kN/m}^2$</p> <p>Imposed load = 4 kN/m^2</p> <p>Total factored load = $1.5 \times (4.88 + 1.875 + 4)$ $= 16.13 \text{ kN/m}^2$</p>	
3	<p>Analysis</p> <p>UDL on landing 1 = 14.06 kN/m^2</p> <p>UDL on landing 2 = 14.06 kN/m^2</p> <p>UDL on flight = 16.13 kN/m^2</p>	

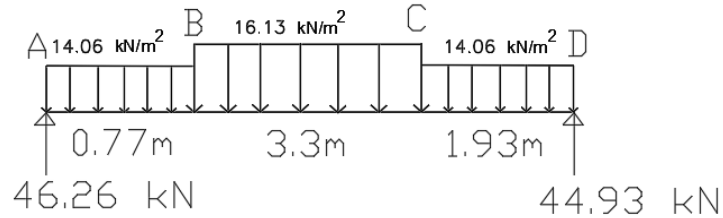
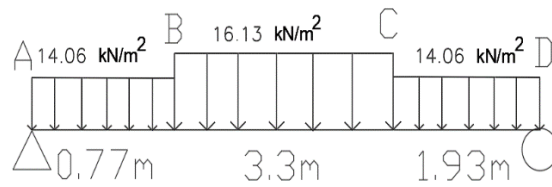

Maximum bending moment in flight is at 2.98m from A.

Maximum BM

$$= 46.26 * 2.98 - 14.06 * 0.77 * (0.77/2 + 2.21) - 16.13 * 2.21 * 2.21/2$$

$$= 70.37 \text{ kNm}$$

AB and CD are landing.
BC is flight.

Note: Although the landing and flight is supported in the beam it is not assumed fix support. This is because the torsion in the beam has been released which means beam won't take any moment from landing and flight. So, assuming simply supported will keep us in safer side.

4	<p>Design of flight</p> <p>For effective depth d,</p> $Mu,lim = 0.133 * f_{ck} * b d^2$ $70.37 * 10^6 = 0.133 * 30 * 1000 * d^2$ <p>On solving,</p> $d = 132.8 \text{ mm} < d_{\text{provided}} \text{ (OK)}$ <p>Determination of main reinforcement:</p> $M_U = 0.87 * f_y * A_{st} * d * \left(1 - \frac{f_y * A_{st}}{f_{ck} * b * d}\right)$ $70.37 * 10^6 = 0.87 * 500 * A_{st} * 142 * \left(1 - \frac{500 * A_{st}}{30 * 1000 * 142}\right)$	$D_{\text{provided}} = 175 \text{ mm}$ $d_{\text{provided}} = 175 - 25 - 16/2 = 142 \text{ mm}$
5	$A_{st} = 1354.6 \text{ mm}^2$ <p>Required spacing of 16mm bars, c/c spacing = $1000 * 64 * \pi / 1354.6 = 148.4 \text{ mm}$ Provide 16 mm dia. bars @ 145mm c/c $A_{st, \text{ provided}} = 1386.63 \text{ mm}^2$</p> <p>Development Length Check</p> $L_d = \Phi * f_s / 4 \tau$ $= 725 \text{ mm}$ $M_1 = 39.34 \text{ KNm}$ $V = 46.26 \text{ KN}$	
6	$M_1 / V = 850 \text{ mm}$ <p>So, it is safe in development length</p> <p>Distribution Reinforcement:</p> $A_{st \text{ min}} = 0.12\% \text{ of } bD$ $= 210 \text{ mm}^2$ <p>Provide 10 mm bars as distribution reinforcement</p>	
7	$\text{Spacing} = 1000 * 25 * \pi / 210 = 374 \text{ mm}$ <p>Provide 10 mm dia. bars @ 300 mm c/c.</p>	

7.6 Design of Basement Wall

Basement wall is constructed to retain the earth and to prevent moisture from seeping into the building. Since the basement wall is supported by the mat foundation, the stability is ensured and the design of the basement wall is limited to the safe design of vertical stem.

Basement walls are exterior walls of underground structures (tunnels and other earth sheltered buildings), or retaining walls must resist lateral earth pressure as well as additional pressure due to other type of loading. Basement walls carry lateral earth pressure generally as vertical slabs supported by floor framing at the basement level and upper floor level. The axial forces in the floor structures are, in turn, either resisted by shear walls or balanced by the lateral earth pressure coming from the opposite side of the building.

Although basement walls act as vertical slabs supported by the horizontal floor framing, keep in mind that during the early construction stage when the upper floor has not yet been built the wall may have to be designed as a cantilever.

The design is based on the assumption that the backfilling of soil is done after the construction of the ground floor. This allows for the economy in design considering the wall to be supported by both the mat foundation as a cantilever action. The design for both buildings is the same.

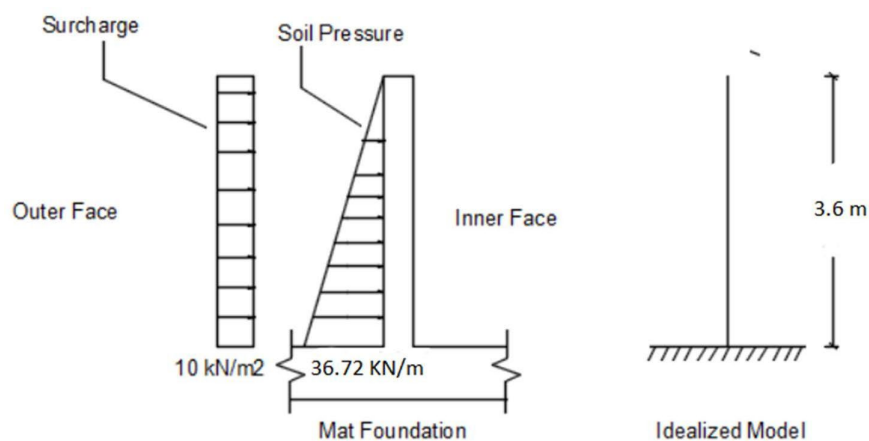

Figure 16: Design of Basement Wall

Known Data

Concrete Grade = M30

Steel Grade = Fe500

1. Design Constants

Floor to floor height, basement height, $h = 3.6\text{m}$

Unit weight of soil, $\gamma = 17\text{KN/m}^3$

Angle of internal friction of soil, $\theta = 30$

Surcharge produced due to vehicular movement, $W_s = 10\text{KN/m}^3$

Safe bearing capacity of soil, $q_s = 140\text{KN/m}^3$

2. Moment calculation

Coefficient of earth pressure, $K_a = \frac{1-\sin\theta}{1+\sin\theta} = \frac{1-\sin 30}{1+\sin 30} = 0.333$

Lateral load due to soil pressure, $P_a = \frac{1}{2} * K_a * \gamma * h^2$
 $= \frac{1}{2} * 0.33 * 17 * 3.6^2$
 $= 36.72\text{KN/m width of wall.}$

Lateral load due to surcharge load, $P_s = K_a * W_s * h$
 $= 0.333 * 10 * 3.6$
 $= 12 \text{ KN/m width of wall.}$

Characteristics bending moment of wall is calculated as given below. Since the weight of wall gives insignificant moment, it can be neglected in the design.

$M_c = \frac{P_a * h}{3} + \frac{P_s * h}{2}$
 $= \frac{36.72 * 3.6}{3} + \frac{12 * 3.6}{2}$
 $= 65.66 \text{ KN-m/m width of wall.}$

Design moment, $M = 1.5 * M_c$
 $= 1.5 * 65.66$
 $= 98.5 \text{ KNm/m}$

3. Approximate design of section

Let effective depth of wall = d .

For Fe500,

$M = 0.133 * f_{ck} * b * d^2$

$98.5 * 10^6 = 0.133 * 30 * 1000 * d^2$

On solving,

We get $d = 157.12 \text{ mm}$

Let the clear cover be 30mm and bar size \varnothing is 16mm.

Overall depth of wall = $157.12 + 30 + 8$
 $= 195.12\text{mm}$

Take $D = 210\text{mm}$

$$d = 200 - 30 - 8$$

$$= 162$$

(IS 456:2000 Cl 32.5.1)

Two curtain of reinforcement need to be provided.

4. Calculation of main steel reinforcement

$$M = 0.87 * f_y * A_{st} * d * \left(1 - \frac{A_{st} * f_y}{b * d * f_{ck}}\right)$$

$$98.5 * 10^6 = 0.87 * 500 * A_{st} * 162 * \left(1 - \frac{A_{st} * 500}{1000 * 162 * 30}\right)$$

On solving,

$$\text{We get } A_{st} = 1692.45 \text{ mm}^2$$

$$A_{st, \min} = 0.0012 * b * D \quad (\text{IS 456:2000 Cl 32.5.a.1})$$

$$= 240 \text{ mm}^2$$

$$\text{Maximum diameter of bar} = D/8 = 25 \text{ mm} > 16 \text{ mm} \quad (\text{IS 13920})$$

$$\text{Area of one bar} = 201.06 \text{ mm}^2$$

$$\begin{aligned} \text{Spacing of bars} &= \frac{1000 * 201.06}{1692.45} \\ &= 118.79 \text{ mm} \end{aligned}$$

Provide 16mm Ø bars at 100mm c/c.

$$\text{Maximum spacing} = 3 * D \text{ or } 450 \text{ mm}$$

$$= 450 \text{ mm} > 100 \text{ mm (OK)} \quad (\text{IS 456:2000 Cl 32.5.b})$$

So,

$$A_{st \text{ provided}} = 2010.6 \text{ mm}^2$$

5. Check for shear

The critical section for shear is taken at distance “d” from the face of support. Thus the critical section is at $d=0.162\text{m}$ from the top of mat foundation, i.e. 3.438m below the top edge of wall.

Shear force at critical section is

$$V_u = (3.33 * 3.438 + \frac{1}{2} * \frac{20.38}{3.6} * 3.438^2)$$

$$= 11.448 + 33.456$$

$$= 44.9 \text{ KN}$$

$$V = 1.5 * V_u$$

$$= 1.5 * 44.9$$

$$= 67.35 \text{ KN}$$

$$\text{Nominal shear stress, } T_v = \frac{V}{b * d}$$

$$\begin{aligned}
&= \frac{67.65 \cdot 1000}{1000 \cdot 162} \\
&= 0.4177 \text{ N/mm}^2
\end{aligned}$$

$$100A_s/bd = 1.24$$

For M30, from table 19 (IS 456:2000)

$$T_c = 0.7 \text{ N/mm}^2$$

From Table 20 (IS 456:2000)

$$T_{c, \max} = 3.5 \text{ N/mm}^2$$

Here,

$$T_{c, \max} > T_c > T_v \quad \text{(Hence, safe in shear)}$$

6. Check for deflection

$$L_{\text{eff}} = \text{Clear span} + d$$

$$= (3.6 - 0.6) + 0.162$$

$$= 3.162 \text{ m}$$

$$\begin{aligned}
\text{Allowable deflection} &= \frac{L_{\text{eff}}}{250} \\
&= (3.162 \cdot 1000 / 250) \\
&= 12.648 \text{ mm}
\end{aligned}$$

(IS 456:2000 Cl 23.2.a)

$$\begin{aligned}
\text{Actual deflection} &= \frac{P_s \cdot (L_{\text{eff}})^3}{8EI} + \frac{Pa \cdot (L_{\text{eff}})^3}{30EI} \\
&= 0.002590 + 0.00211 \\
&= 4.709 \text{ mm} < 12.648 \text{ mm (Safe)}
\end{aligned}$$

7. Calculation of horizontal reinforcement steel bar

$$\begin{aligned}
\text{Min reinforcement} &= 0.002 \cdot b \cdot D \quad \text{(IS 456:2000 Cl 32.5.c.1)} \\
&= 0.002 \cdot 1000 \cdot 200 \\
&= 400 \text{ mm}^2
\end{aligned}$$

As the temperature change occurs at the front face of the basement wall,

2/3rd of horizontal reinforcement is provided at the front face and

1/3rd of horizontal reinforcement is provided at the inner face.

$$\begin{aligned}
\text{Temp reinforcement at the front face} &= (2/3) \cdot 400 \\
&= 266.7 \text{ mm}^2
\end{aligned}$$

Provide 10 mm bars.

Area of one bar = 78.53 mm²

$$\text{Spacing} = \frac{1000 \cdot 78.53}{266.7}$$
$$= 294.45 \text{ mm}$$

Maximum spacing = (3*D or 450mm)

$$= 450 \text{ mm} > 294.45 \text{ (OK)} \quad (\text{IS 456:2000 Cl 32.5.d})$$

So provide 10mm Ø bars at 250mm c/c at front face.

Temp reinforcement at inner face = (1/3) * 400

$$= 133.33 \text{ mm}^2$$

$$\text{Spacing} = \frac{1000 \cdot 78.53}{133.33}$$
$$= 588.98 \text{ mm}$$

So provide 10 mm Ø bars at 450 mm c/c at inner face.

8. Curtailment of reinforcement

No bars can be curtailed in less than L_d distance from the bottom of stem.

$$L_d = \frac{\phi \cdot \sigma}{4 \cdot T \cdot b \cdot d} \quad (\text{IS 456:2000 Cl 26.2.1})$$
$$= \frac{16 \cdot 0.87 \cdot 500}{4 \cdot 1.6 \cdot 1.5}$$
$$= 725 \text{ mm}$$

The curtailment of bars can be done in two layers, 1/3 and 2/3 heights of stem above the base.

Let us curtail bars only at 1/3 i.e. 1.054m from base (2.108 m from top)

Lateral load at 2.108 m due to soil pressure, P_a

$$= \frac{1}{2} \cdot 11.93 \cdot 2.108$$

= 12.57 kN/m width of wall.

Lateral load at 2.108m due to surcharge load, P_s

$$= 3.33 \cdot 2.108$$

= 7.02 kN/m width of wall.

Characteristics bending moment at 2.108 m

$$M = 1.5 \cdot \left(\frac{12.57 \cdot 2.108}{3} + \frac{7.02 \cdot 2.108}{2} \right)$$
$$= 1.5 \cdot (8.83 + 7.39)$$
$$= 24.34 \text{ Kn-m per unit width of wall.}$$

Since the moment is less than half the moment at the base of the wall, spacing of the vertical reinforcement is doubled from 1054 mm from the base of the wall.

Provide 16mm Ø bars at 200mm c/c from 1054mm.

7.7 Design of Lift Core Wall

The design of lift wall has been designed as the reinforced wall monolithic to the other structural members which is subjected to the direct compression. They are designed as per the empirical procedure given in the **IS-13920, clause 9.1.2** The minimum thickness of the wall should be 150 mm. The design of a wall shall account of the actual eccentricity of the vertical force subjected to the minimum value of $0.05t$. The vertical load transmitted to a wall by a discontinuous concrete floor or roof shall be assumed to act at one-third the depth of the bearing area measured from the span face of the wall. Where there is an in-situ continuous concrete floor over the wall, the load shall be assumed to act the center of the wall. The resultant eccentricity of the total vertical load on a braced wall at any level between horizontal lateral supports, shall be calculated on the assumption that the resultant eccentricity of all the vertical loads above the upper support is zero.

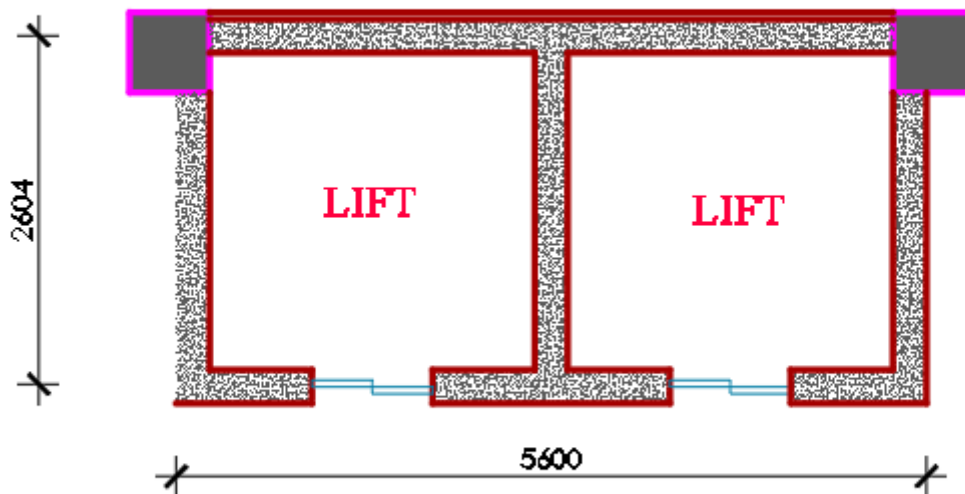

Figure 17: Lift Core

Design:

Known Data:

Total length of wall = 17.45m

Height of wall = 3.6m

Assume,

Wall thickness (t) = 300mm

Check for the slenderness ratio

$$\begin{aligned}\text{Effective height of wall } (h_E) &= 0.75 * H \\ &= 2.7\text{m}\end{aligned}$$

$$\begin{aligned}\text{Slenderness ratio} &= \frac{h_e}{t} \\ &= 9 < 30 \text{ (OK)} \quad \text{IS 456:2000 Cl 32.2.3}\end{aligned}$$

Minimum eccentricity :

$$\begin{aligned}e(\text{min}) &= 0.05 * t && \text{IS 456:2000 Cl 32.2.3} \\ &= 15\text{mm}\end{aligned}$$

Lift wall :

$$\text{Length} = 17.45\text{m}$$

$$\text{Characteristics load} = 17.45 * 0.3 * 3.6 * 25 = 507.87 \text{ KN}$$

$$\text{Weight of lift equipment} = 3700\text{kg}$$

$$\text{Weight of passengers} = 800 \text{ kg}$$

$$\text{Total weight} = 4500\text{kg}$$

Applying impact factor of 100%

$$\begin{aligned}\text{Total weight} &= 900\text{kg} \\ &= 90 \text{ KN}\end{aligned}$$

$$\begin{aligned}\text{Total design load per each floor} &= 1.5 * [507.87 + 90] \\ &= 776.805 \text{ KN}\end{aligned}$$

Load of roof slab :

$$\begin{aligned}\text{Dead load} &= 2 * [0.15 * 25 * 2.17 * 2.55] \\ &= 41.50\text{KN}\end{aligned}$$

$$\begin{aligned}\text{Live load} &= 2 * [2.17 * 2.55 * 1.75] \\ &= 17.36 \text{ KN}\end{aligned}$$

$$\begin{aligned}\text{Total seismic load (W)} &= [776.805 * 8] + \frac{776.805}{2} + 60.16 \\ &= 6663 \text{ KN}\end{aligned}$$

$$h = 32.4\text{m}$$

$$A_h = \frac{Z * I * S_a}{2 * R * g} \quad \text{IS 1893:2016}$$

$$T_x = \frac{0.075 * h^{0.75}}{\sqrt{A_w}} \quad (\text{ For RC structural walls , IS 1893:2016})$$

Where,

$$A_w = \Sigma [A_{wi} * \{0.2 + (\frac{Lw_i}{h})^2\}]$$

We get,

$$A_w = 0.665$$

$$\text{So, } T_x = 1.24$$

Similarly, $T_y = 1.8 \text{ sec.}$

In X-direction:

$$S_a/g = \frac{1.36}{T}$$

$$= 1.096$$

$$A_h = \frac{0.36 \cdot 1.2 \cdot 1.096}{2 \cdot 5}$$

$$= 0.0473$$

$$\text{Base shear (} V_b \text{)} = 315.47 \text{ KN}$$

In Y-direction:

$$S_a/g = \frac{1.36}{T}$$

$$= 0.755$$

$$A_h = \frac{0.36 \cdot 1.2 \cdot 0.755}{2 \cdot 5}$$

$$= 0.0326$$

$$\text{Base shear (} V_b \text{)} = 217.3247 \text{ KN}$$

Table 52: Lateral Force Calculation for Lift Core Design

Floor level	Wi(KN)	hi(m)	Wi*hi ²	Wi*hi ² /ΣWi*hi ²	Lateral force at each storey level		Cumulative lateral force		Moment along	
					Along X	Along Y	Along X	Along Y	X	Y
Roof	449.26	32.4	471615.1776	0.1868	58.9152	40.5848	58.9152	40.5848	1908.8530	1314.94810
Top floor	776.805	28.8	644313.1392	0.2551	80.4890	55.4463	139.4042	96.0311	2318.0840	1596.85435
Sixth floor	776.805	25.2	493302.2472	0.1953	61.6244	42.4511	201.0287	138.4822	1552.9352	1069.76766
Fifth floor	776.805	21.6	362426.1408	0.1435	45.2751	31.1886	246.3037	169.6708	977.94171	673.672928
Fourth floor	776.805	18	251684.82	0.0997	31.4410	21.6587	277.7448	191.3295	565.93849	389.857019
Third floor	776.805	14.4	161078.2848	0.0638	20.1223	13.8616	297.8670	205.1911	289.76050	199.606793
Second floor	776.805	10.8	90606.5352	0.0359	11.3188	7.7971	309.1858	212.9883	122.24271	84.2091161
First floor	776.805	7.2	40269.5712	0.0159	5.0306	3.4654	314.2164	216.4537	36.220063	24.9508492
Ground floor	776.805	3.6	10067.3928	0.0040	1.2576	0.8663	315.4740	217.3200	4.5275079	3.11885615
	6663.7		2525363.309						7776.5033	5356.98567

Using 16mm Ø bars:

Calculation of vertical steel reinforcement:

When lateral load is acting along x direction:

$$M = 7776.503/2 = 3888.28 \text{ KN-m}$$

$$V = 315.46/2 = 157.735 \text{ KN}$$

$$P = 6663.7/2 = 3331.85 \text{ KN}$$

$$d' = 44$$

$$\text{So } d'/D = 0.007 < 0.05$$

Hence for this case we have to use SP-16 chart 35,

$$\frac{M}{f_{ck} * b * d^2} = 0.0133$$

$$\frac{P}{f_{ck} * b * d} = 0.064$$

$$p/f_{ck} = 0$$

So we provide minimum reinforcement

Minimum reinforcement:

$$\begin{aligned} A_{st} &= 0.0025 * 5600 * 300 \\ &= 4200 \text{ mm}^2 \end{aligned}$$

Using 16 mm \emptyset bars,

$$\text{Spacing required} = 260\text{mm}$$

Check for spacing

$$\begin{aligned} \text{Spacing} &< 3t = 3 * 300 = 900\text{mm (OK)} \\ &< 450\text{mm (OK)} \end{aligned}$$

Provide 16mm \emptyset bars at 260mm c/c.

To account for reversal effect, provide vertical reinforcements on both faces of wall.

Horizontal reinforcement:

$$\begin{aligned} A_{st} &= 0.0025 * 2600 * 300 \\ &= 1950 \text{ mm}^2 \end{aligned}$$

Using 16 mm \emptyset bars,

$$\text{Spacing required} = 260\text{mm}$$

Check for spacing

$$\begin{aligned} \text{Spacing} &< 3t = 3 * 300 = 900\text{mm (OK)} \\ &< 450\text{mm (OK)} \end{aligned}$$

Provide 16mm \emptyset bars at 260mm c/c.

To account for reversal effect, provide horizontal reinforcements on both faces of wall.

Ultimate load carrying capacity IS 456:2000 Cl 32.2.5

Ultimate load carrying capacity per unit length of wall is

$$P_u = 0.3 * [t - 1.2e - 2e_a] * f_{ck}$$

$$e = 15\text{mm}$$

$$e_a = 9.72 \text{ mm}$$

$$P_u = 0.3 \cdot [300 - (1.2 \cdot 15) - (2 \cdot 9.72)] \cdot 30$$

$$= 2363.64 \text{ KN/m}$$

Total capacity of wall 1 and 2 in X- direction = 12054.56 KN

Check for shear:

When lateral load is acting in X-direction:

Nominal shear stress, IS 456:2000 Cl 32.4.2

$$T_v = \frac{157.735 \cdot 10^3}{300 \cdot 0.8 \cdot 5.1}$$

$$= 0.128 \text{ N/mm}^2$$

$$\text{Allowable shear stress} = 0.17 \cdot f_{ck}$$

$$= 0.17 \cdot 30$$

$$= 5.1 \text{ N/mm}^2 > T_v$$

$$H_w/L_w = 3.6/5.1 = 0.7 < 1 \text{ (Low wall)}$$

For low wall,

$$T_c = 3 - (H_w/L_w) \cdot k_1 \cdot \sqrt{f_{ck}}$$

$$= (3 - \frac{3.6}{5.7}) \cdot 0.2 \cdot \sqrt{30}$$

$$= 2.59 \text{ N/mm}^2$$

When lateral load is acting in Y-direction:

Nominal shear stress, IS 456:2000 Cl 32.4.2

$$T_v = \frac{72.44 \cdot 10^3}{300 \cdot 0.8 \cdot 2.60}$$

$$= 0.116 \text{ N/mm}^2$$

$$\text{Allowable shear stress} = 0.17 \cdot f_{ck}$$

$$= 0.17 \cdot 30$$

$$= 5.1 \text{ N/mm}^2 > T_v$$

$$H_w/L_w = 3.6/2.6 = 1.38 > 1 \text{ (High wall)}$$

For high wall,

$$T_c = K_2 \sqrt{f_{ck}} \cdot \frac{\frac{H_w}{L_w} + 1}{\frac{H_w}{L_w} - 1}$$

$$= 1.53 \text{ N/mm}^2 > T_v \text{ (OK)}$$

Reinforcement at opening: IS 13920:2016 Cl 9.6.2

Area of opening = 900*2100

No. of horizontal bars interrupted = 8nos

No. of vertical bars interrupted = 4nos

Total area of reinforcement = 2412.68mm^2

Now, area of bars to be provided around the opening per layer = 2412.68 mm^2

Take 28 mm \emptyset bars per layer of reinforcement at each side of the opening.

7.8 Design of Mat foundation

Foundations are the subsurface structure that transfers loads from the buildings or individual to the earth. Foundations must be designed to transfer the loads without exceeding the safe bearing capacity. Additionally, it must prevent excessive settlement, and minimize differential settlement. Most of the foundations used in structures are classified as:

- Footing
- Combined footing
- Raft or mat foundation.
- Pile foundation
- Isolated

Raft foundation

Normally, in residential buildings load from superstructure are small enough to be transmitted by isolated footings, spread footings and combined footings. However, in large commercial buildings the loads to be transmitted from the superstructure are heavy to the extent that the individual footings might overlap or require more than 50% of total area. In such cases, a large area footing called raft footing is required. This footing is preferred even in cases of low soil bearing pressure or high settlement.

Method of Analysis

Raft foundation is designed using rigid foundation design method where the foundation is assumed to be rigid and pressure distribution on soil is linearly varying. The analysis requires determination of contact pressure under the raft, which is done as per **IS : 2950 (Part I) – 1981**

Appendix D.

The raft is analyzed as a whole in each of the two perpendicular directions. In case of uniform conditions when the variations in adjacent column loads and column spacing do not exceed 20% of the higher value, raft may be divided into perpendicular strips of widths equal to the distance between mid-spans and each strip may be analyzed as an independent beam with known column loads and known contact pressures.

Building 1:

Known Data:

Unit weight of soil(γ) = 17KN/m³

Service load (P) = 60073.19 KN

Grade of the concrete = M30

Grade of the steel = Fe500

Bearing capacity of the soil(q) = 140KN/m³

Angle of response of the soil(ϕ) = 30°

As per **IS 1893:(Part 1): 2016, CL 6.3.5.2**, when earthquake forces are included, net bearing pressure in soil can be increased depending on the type of the foundation and type of soil. For the raft foundation and stiff soil, this can be increased by **25 %**.

Considering axial transfer of the load to the foundation, the area of the soil required to sustain the foundation load is given as:

$$\begin{aligned}\text{Area of soil required} &= \frac{\text{service load} + \text{self weight of foundation}}{\text{safe bearing capacity}} \\ &= \frac{60073.19 * 1.1}{140} \quad (\text{self weight is taken as 10\% of axial load}) \\ &= 472 \text{ m}^2\end{aligned}$$

Plinth area = 419.25 m²

Since area of soil required > 0.5*(Plinth area), mat foundation should be provided.

Location of geometrical centroid (\bar{x} , \bar{y}) = (9.75, 10.75)

Calculation:

Response for factored load combinations i.e. (1.5DL + LL)

$$\Sigma P = 60073.19 \text{ KN}$$

$$\Sigma M_x = 152.556 \text{ KN-m}$$

$$\Sigma M_y = -1201.8 \text{ KN-m}$$

$$\Sigma (P * X) = 911639.6$$

$$\Sigma (P * Y) = 980431$$

Location of the center of resultant forces:

$$\begin{aligned}X_f &= \frac{\Sigma (P * X)}{\Sigma P} \\ &= 10.1169 \text{ m}\end{aligned}$$

$$\begin{aligned}Y_f &= \frac{\Sigma (P * Y)}{\Sigma P} \\ &= 10.88 \text{ m}\end{aligned}$$

Location of Geometrical Centroid: (\bar{x} , \bar{y}) = (9.75, 10.75)

Eccentricity:

$$e_x = X_f - \bar{x}$$
$$= 0.367\text{m}$$

$$e_y = Y_f - \bar{y}$$
$$= 0.13\text{m}$$

Overall Dimension:

$$L = 23.5\text{m}$$

$$B = 25.5\text{m}$$

Area MOI

$$I_{XX} = \frac{L*B^3}{12}$$
$$= 3.247*10^4 \text{ m}^4$$

$$I_{YY} = \frac{B*L^3}{12}$$
$$= 2.757*10^4 \text{ m}^4$$

Stress at different coordinates:

$$\sigma = \frac{\Sigma P}{A} \pm \frac{M_{yy}}{I_{yy}} * X \pm \frac{M_{xx}}{I_{xx}} * Y$$

$$M_{yy} = \Sigma P * e_x + \Sigma M_y$$

$$M_{xx} = \Sigma P * e_y + \Sigma M_x$$

For bearing pressure check (Serviceability condition)

$$\Sigma P = 60073.19 \text{ KN}$$

$$M_{yy} = (60073.19 * 0.367) + (-152.556/1.5)$$
$$= 7707.81 \text{ Kn-m}$$

$$M_{xx} = (60073.19 * 0.13) + (-1201.8/1.5)$$
$$= 21245.66 \text{ Kn-m}$$

For the design of the mat foundation (Factored)

$$\Sigma P = 90109.79 \text{ KN}$$

$$M_{yy} = (90109.79 * 0.367) + (-1201.8)$$
$$= 31868.49 \text{ Kn-m}$$

$$M_{xx} = (90109.79 * 0.13) + (-152.556)$$
$$= 11561.71 \text{ Kn-m}$$

Extreme coordinates w.r.t geometrical center (for bearing pressure check)

$$(x, y): (\pm 23.5/2, \pm 25.5/2)$$
$$= (\pm 11.75, \pm 12.75)$$

Stress at extreme corners:

$$(11.75, 12.75) = 112.32 \text{ KN/m}^2$$

$$(-11.75, 12.75) = 94.21 \text{ KN/m}^2$$

$$(11.75, -12.75) = 100.29 \text{ KN/m}^2$$

$$(-11.75, -12.75) = 88.16 \text{ KN/m}^2$$

So, the stress at extreme corners is within the safe bearing pressure of soil. (140KN/m²)

Design stress under different columns (1.5(DL + LL))

Table 53: Design Stress for Building 1

Label	P(KN)	MX	MY	X coordinate	Y coordinate	p*x	p*y
C 17 COLUMN	716.8221	9.8742	-35.4724	0	0	0	0
C 13 COLUMN	1084.834	-6.0137	-78.9402	0	5.5	0	5966.585
C9 COLUMN	1161.043	3.0827	55.9055	0	11	0	12771.48
C6 COLUMN	1077.153	-1.7138	-93.5836	0	15.5	0	16695.87
C 21 COLUMN	586.2821	-28.3729	-38.7016	0	21.5	0	12605.07
C18 COLUMN	1456.689	192.328	-12.1739	6.5	0	9468.476	0
C14 COLUMN	5680.022	4.3583	31.4408	6.5	5.5	36920.14	31240.12
C10 COLUMN	5618.402	-12.0368	-15.2435	6.5	11	36519.61	61802.42
C7 COLUMN	5547.893	-25.1158	46.4323	6.5	15.5	36061.3	85992.34
C22 COLUMN	1605.655	-196.877	-17.0593	6.5	21.5	10436.76	34521.58
C19 COLUMN	1456.645	193.4412	-12.9008	13	0	18936.39	0
C15 COLUMN	6020.416	-17.5689	1.5287	13	5.5	78265.4	33112.29
C11 COLUMN	6032.965	10.1418	0.3199	13	11	78428.55	66362.62
C8 COLUMN	6288.243	-15.0032	11.211	13	15.5	81747.15	97467.76
C23 COLUMN	1676.112	-194.708	-18.2163	13	21.5	21789.45	36036.4
C20 COLUMN	1501.375	91.238	6.2647	19.5	0	29276.81	0
C16 COLUMN	4245.726	-10.4281	-49.6855	19.5	5.5	82791.66	23351.49
C12 COLUMN	3902.74	-34.5149	-76.4448	19.5	11	76103.43	42930.14
C5 COLUMN	4023.122	0.6754	-113.365	19.5	15.5	78450.87	62358.38
C24 COLUMN	1731.749	-92.4116	4.1156	19.5	21.5	33769.11	37232.61
	90109.79	-152.556	-1201.8			911639.6	980431

For design, the raft is divided into 4 strips in the X-direction and 5 strips in the Y-direction, and each strip is treated as a continuous beam. Bending moments are obtained using coefficients suggested by **IS 456: 2000, Table 12**. For the calculation of bending moment, the maximum value of stress under the column for each strip is used and calculations are done for both X and Y directions.

$$\text{Bending moment at support} = \frac{q \cdot l^2}{10}$$

$$\text{Bending moment at midspan} = \frac{q \cdot l^2}{12}$$

Where, q= maximum stress under a column for a given strip.

Along X-direction:

Table 54: Moment Calculation for Foundation Design of Building 1 in X-direction

Strip Beam	Width (m)	LMax (m)	q (kN/m ²)	Support Moment (kNm/m)	Span Moment (kNm/m)	Remarks
1,1	5	6.5	165.478	699.14455	582.6205	Max
2,2	5.25	6.5	163.342	690.11995	575.1	
3,3	5	6.5	161.74	683.3515	569.4596	
4,4	5.5	6.5	159.782	675.07895	562.5658	
5,5	4.75	6.5	157.824	666.8064	555.672	
			Max	699.14455	582.6205	

Along Y- direction:

Table 55: Moment Calculation for Foundation Design of Building 1 in Y-direction

Strip Beam	Width (m)	L Max (m)	q (kN/m ²)	Support Moment (kNm/m)	Span Moment (kNm/m)	Remarks
A-A	5.25	5.5	142.936	432.3814	360.3178333	
B-B	6.5	5.5	150.45	455.11125	379.259375	
C-C	6.5	5.5	157.964	477.8411	398.2009167	
D-D	5.25	5.5	165.478	500.57095	417.1424583	
				500.57095	417.1424583	Max

Maximum moment of all four values is used for determination of depth of raft foundation i.e.

$$M(\max) = 699.15 \text{ KN-m.}$$

Manual Design:

Depth from moment consideration:

For Fe500, from SP16,

$$M = 0.133 \cdot f_{ck} \cdot b \cdot d^2$$

$$699.15 \cdot 10^6 = 0.133 \cdot 30 \cdot 1000 \cdot d^2$$

On solving, we get

$$d = 418.6 \text{ mm}$$

Since footing is critical in shear, depth is increased.

Adopt D = 925 mm

Provide 20mm Ø bars and 75 mm effective cover.

Then,

$$d = 925 - \frac{20}{2} - 75$$

$$= 840\text{mm.}$$

Check for two-way shear:

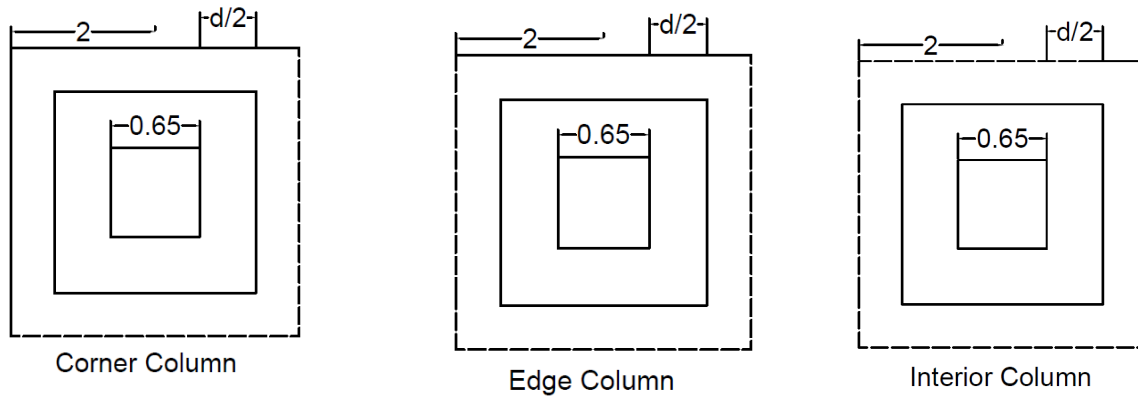

Figure 18: Types of Columns Used in Foundation

The check is for the most critical interior column:

$$\text{Nominal shear stress} = \frac{V}{b_0 * d} \quad \text{IS 456:2000 Cl 31.6.2.1}$$

b_0 = perimeter

From IS 456:2000 Cl 36.3.1,

$$T_v \leq k_s T_c ; k_s = (0.5 + \beta_c) \leq 1 \quad \beta_c = L/B$$

Here, $\beta_c = 1$.

So $K_s = 1$

$$T_c = 0.25 \sqrt{f_{ck}}$$

$$= 1.37$$

So, Nominal shear stress (T_v) should be less than 1.37 N/mm²

From clause 31.6.1,

Critical section for shear shall be at a distance $d/2$ from the periphery of column.

$$b_0 = 4 * (650 + 840)$$

$$= 5960\text{mm}$$

$$d = 740\text{mm}$$

$$\text{Maximum load (V)} = 6288.24 \text{ KN}$$

$$T_v = \frac{6288.24 \cdot 10^3}{5960 \cdot 840}$$

$$= 1.256 \text{ N/mm}^2 < 1.37 \text{ N/mm}^2 (\text{OK})$$

Area of steel:

Minimum area of steel = 0.12% of Bd IS 456:2000 Cl 26.5.2.1

$$= 1008 \text{ mm}^2$$

In X direction

- a. Area of steel at supports (bottom bars)

IS 456:2000 Annex G

$$M_u = 0.87 \cdot f_y \cdot A_{st} \cdot d \left(1 - \frac{A_{st} \cdot f_y}{b \cdot d \cdot f_{ck}}\right)$$

Here $M_u = 699.14 \text{ KN-m}$

On solving,

$$A_{st} = 1992.124 \text{ mm}^2 > A_{st}(\text{min})$$

For 20 mm bars

$$A_b = 314.159 \text{ mm}^2$$

Spacing of bars:

$$S_v = \frac{A_b \cdot 1000}{A_{st}}$$

$$= 157.7 \text{ mm}$$

Provide 20mm \emptyset bars at 150mm c/c.

$$A_{st} \text{ provided} = 2094.4 \text{ mm}^2.$$

- b. Area of steel at midspan (top bars)

IS 456:2000 Annex G

$$M_u = 0.87 \cdot f_y \cdot A_{st} \cdot d \left(1 - \frac{A_{st} \cdot f_y}{b \cdot d \cdot f_{ck}}\right)$$

Here $M_u = 582.62 \text{ KN-m}$

On solving,

$$A_{st} = 1648.38 \text{ mm}^2 > A_{st}(\text{min})$$

For 20mm bars

$$A_b = 314.159 \text{ mm}^2$$

Spacing of bars:

$$S_v = \frac{A_b \cdot 1000}{A_{st}}$$

$$= 190.58 \text{ mm}$$

Provide 20mm \emptyset bars at 180 mm c/c.

$$A_{st} \text{ provided} = 1745.33 \text{ mm}^2.$$

In Y direction

- a. Area of steel at supports (bottom bars)

IS 456:2000 Annex G

$$M_u = 0.87 * f_y * A_{st} * d \left(1 - \frac{A_{st} * f_y}{b * d * f_{ck}} \right)$$

Here $M_u = 500.57 \text{ KN-m}$

On solving,

$$A_{st} = 1409.33 \text{ mm}^2 > A_{st}(\text{min})$$

For 20mm bars

$$A_b = 314.159 \text{ mm}^2$$

Spacing of bars:

$$S_v = \frac{A_b * 1000}{A_{st}}$$

$$= 222.91$$

Provide 20mm \emptyset bars at 150mm c/c.

$$A_{st} \text{ provided} = 2094.4 \text{ mm}^2.$$

- b. Area of steel at midspan (top bars)

IS 456:2000 Annex G

$$M_u = 0.87 * f_y * A_{st} * d \left(1 - \frac{A_{st} * f_y}{b * d * f_{ck}} \right)$$

Here $M_u = 417.14 \text{ KN-m}$

On solving,

$$A_{st} = 1168.69 \text{ mm}^2 > A_{st}(\text{min})$$

For 20mm bars

$$A_b = 314.159 \text{ mm}^2$$

Spacing of bars:

$$S_v = \frac{A_b * 1000}{A_{st}}$$

$$= 268.81 \text{ mm}$$

Provide 20mm \emptyset bars at 180mm c/c.

$$A_{st} \text{ provided} = 1745.33 \text{ mm}^2.$$

Check for development length

Bond stress for M30 concrete (T_{bd}) = 1.5

IS 456:2000 Cl 26.2.1.1

$$L_d = \frac{\phi * \sigma}{4 * T_{bd}}$$

$$= \frac{20 \times 0.87 \times 500}{4 \times 1.6 \times 1.5}$$

$$= 906.25 \text{ mm}$$

L_o = effective depth (d) or 12ϕ whichever is greater.
 $= 840 \text{ mm}$

$$1.3M_1/V = \frac{1.3 \times 699.15}{6288.24}$$

$$= 144.5 \text{ mm}$$

$$1.3 \frac{M_1}{V} + L_o = 1008.29 > L_D . \text{ Hence OK}$$

Load transfer from column to footing

$$\text{Nominal bearing stress in column} = \frac{P}{A}$$

$$= \frac{6288.24 \times 10^3}{650 \times 650}$$

$$= 14.88 \text{ N/mm}^2$$

$$\text{Permissible bearing stress} = 0.45 \times f_{ck}$$

$$= 0.45 \times 30$$

$$= 13.5 \text{ N/mm}^2 < \text{nominal stress}$$

So,

There is need to provide dowel bars to transfer column load.

$$\text{Excess bearing stress} = 14.88 - 13.5 = 1.38 \text{ N/mm}^2$$

$$A_{sc} = \frac{1.38 \times A_c}{0.67 \times f_y} = 1750.45 \text{ mm}^2$$

Using 12 mm diameter dowel bars, no. of bars = 15.47 = 16 nos.

Since footing thickness is less than 1m, there is no need to provide side reinforcement.

Chair bars

As per SP 34, suggested spacing of chair bars is 30 times its diameter with at least 12 mm as its diameter. Providing 16mm chair bars @ 480mm c/c.

From manual design:

Along X direction, provide 20 mm ϕ bars @ 150 mm c/c at supports and @ 180 mm c/c at midspan.

Along Y direction, provide 20 mm ϕ bars @ 150 mm c/c at supports and @ 180 mm c/c at midspan.

Chair bars 16 mm @ 480 mm c/c

Building 2:

Known Data:

Unit weight of soil(γ) = 17KN/m³

Service load (P) = 52,340.762 KN

Grade of the concrete = M30

Grade of the steel = Fe500

Bearing capacity of the soil(q) = 140KN/m³

Angle of response of the soil(ϕ) = 30°

As per **IS 1893:(Part 1): 2016, CL 6.3.5.2**, when earthquake forces are included, net bearing pressure in soil can be increased depending on the type of the foundation and type of soil. For the raft foundation and stiff soil, this can be increased upto **25 %**.

Considering axial transfer of the load to the foundation, the area of the soil required to sustain the foundation load is given as:

$$\begin{aligned}\text{Area of soil required} &= \frac{\text{service load+self weight of foundation}}{\text{safe bearing capacity}} \\ &= \frac{52340.762*1.1}{140} \text{(self weight is taken as 10\% of axial load)} \\ &= 411.24 \text{ m}^2\end{aligned}$$

Plinth area = 434.3 m²

Since area of soil required > 0.5*(Plinth area), mat foundation should be provided.

Location of geometrical centroid (\bar{x} , \bar{y}) = (10.1,10.75)

Calculations:

Response for factored load combinations i.e. (1.5DL + LL)

$$\Sigma P = 78,511.14 \text{ KN}$$

$$\Sigma M_x = 105.228 \text{ KN-m}$$

$$\Sigma M_y = -748.616 \text{ KN-m}$$

$$\Sigma(P*X) = 881881.53$$

$$\Sigma(P*Y) = 1029667$$

Location of center of resultant forces:

$$\begin{aligned}X_f &= \frac{\Sigma(P*X)}{\Sigma P} \\ &= 11.23\text{m}\end{aligned}$$

$$\begin{aligned}Y_f &= \frac{\Sigma(P*Y)}{\Sigma P} \\ &= 13.115\text{m}\end{aligned}$$

Location of Geometrical Centroid : (\bar{x} , \bar{y}) = (11.55,12.75)

Eccentricity:

$$e_x = X_f - \bar{x}$$
$$= -0.32\text{m}$$

$$e_y = Y_f - \bar{y}$$
$$= 0.365\text{m}$$

Overall Dimension:

$$L = 23.1\text{m}$$

$$B = 25.5\text{m}$$

Area MOI

$$I_{XX} = \frac{L*B^3}{12}$$
$$= 3.2*10^4 \text{ m}^4$$

$$I_{YY} = \frac{B*L^3}{12}$$
$$= 2.62*10^4 \text{ m}^4$$

Stress at different coordinates:

$$\sigma = \frac{\Sigma P}{A} \pm \frac{M_{yy}}{I_{yy}} * X \pm \frac{M_{xx}}{I_{xx}} * Y$$

$$M_{yy} = \Sigma P * e_x + \Sigma M_y$$

$$M_{xx} = \Sigma P * e_y + \Sigma M_x$$

For bearing pressure check (Serviceability condition)

$$\Sigma P = 52,340.762 \text{ KN}$$

$$M_{yy} = (52,340.762 * -0.32) + (-748.616/1.5)$$
$$= -17248.12 \text{ Kn-m}$$

$$M_{xx} = (52,340.762 * 0.365) + (105.2285/1.5)$$
$$= 19,174.53 \text{ Kn-m}$$

For design of mat foundation (Factored)

$$\Sigma P = 78,511.143 \text{ KN}$$

$$M_{yy} = (78,511.143 * -0.32) + (-748.616)$$
$$= -25622.64 \text{ Kn-m}$$

$$M_{xx} = (78,511.143 * 0.365) + (105.2285)$$
$$= 28761.79 \text{ Kn-m}$$

Extreme coordinates w.r.t geometrical center (for bearing pressure check)

$$(x, y): (\pm 23.1/2, \pm 25.5/2)$$
$$= (\pm 11.55, \pm 12.75)$$

Stress at extreme corners:

$$(11.55, 12.75) = 76.201 \text{KN/m}^2$$

$$(-11.55, 12.75) = 116.79 \text{KN/m}^2$$

$$(11.55, -12.75) = 60.92 \text{KN/m}^2$$

$$(-11.55, -12.75) = 101.51 \text{KN/m}^2$$

So the stress at extreme corners is within the safe bearing pressure of soil. (140KN/m²)

Design stress under different columns (1.5(DL + LL))

Table 56: Design Stress Calculation for Building 2

Column	X(m)	Y(m)	Stress
C15	2	2	98.54825
C16	2	7.5	103.4433
C17	2	13	108.3383
C6	2	17.5	112.3433
C1	2	23.5	117.6833
C14	6	2	109.0883
C23	6	7.5	113.9833
C24	6	13	118.8783
C7	6	17.5	122.8833
C2	6	23.5	128.2233
C13	10.5	2	120.9458
C22	10.5	7.5	125.8408
C25	10.5	13	130.7358
C18	10.5	17.5	134.7408
C3	10.5	23.5	140.0808
C12	16.2	2	135.9653
C21	16.2	7.5	140.8603
C20	16.2	13	145.7553
C19	16.2	17.5	149.7603
C4	16.2	23.5	155.1003
C11	22.2	2	151.7753
C10	22.2	7.5	156.6703
C9	22.2	13	161.5653

C8	22.2	17.5	165.5703
C5	22.2	23.5	170.9103

For design, raft is divided in 5 strips in X- direction and 5strips in Y- direction, and each strip is treated as continuous beam. Bending moments are obtained using coefficients suggested by **IS 456: 2000, Table 12**. For calculation of bending moment, the maximum value of stress under column for each strip is used and calculations are done for both X and Y directions.

$$\text{Bending moment at support} = \frac{q \cdot l^2}{10}$$

$$\text{Bending moment at midspan} = \frac{q \cdot l^2}{12}$$

Where, q= maximum stress under a column for a given strip.

Along X-direction:

Table 57: Moment Calculation for Foundation Design of Building 2 in X-direction

Strip Beam	Width (m)	L(Max)	q (KN/m2)	Support Moment (KNm/m)	Span Moment (KNm/m)	Remarks
1,1	5	6	170.9103	615.27	512.73	Max
2,2	5.25	6	165.5703	596.052	496.71	
3,3	5	6	161.5653	581.634	484.695	
4,4	5.5	6	156.6703	564.012	470.01	
5,5	4.75	6	151.7753	546.372	455.31	
				615.27	512.73	Max

Along Y- direction:

Table 58: Moment Calculation for Foundation Design of Building 2 in Y-direction

Strip Beam	Width (m)	L Max (m)	q (kN/m2)	Support Moment (kNm/m)	Span Moment (kNm/m)	Remarks
A-A	4	6	117.6833	423.655	353.0466	
B-B	4.25	6	128.2233	461.59	384.2294427	
C-C	5.1	6	140.0808	504.3277	420.27309	
D-D	5.85	6	155.1003	561.27708	467.7309	
E-E	3.85	6	170.9103	615.27	512.73	
				615.27	512.73	Max

Maximum moment of all four values is used for determination of depth of raft foundation i.e.

$$M(\max) = 615.27 \text{ KN-m.}$$

Manual Design:

Depth from moment consideration:

For Fe500, from SP16,

$$M = 0.133 * f_{ck} * b * d^2$$

$$615.27 * 10^6 = 0.133 * 30 * 1000 * d^2$$

On solving, we get

$$d = 392.86 \text{ mm}$$

Since footing is critical in shear, depth is increased.

Adopt $D = 925 \text{ mm}$

Provide $20 \text{ mm } \varnothing$ bars and 50 mm clear cover.

Then,

$$\begin{aligned} d &= 900 - \frac{20}{2} - 75 \\ &= 840 \text{ mm.} \end{aligned}$$

Check for two way shear:

The check is for the most critical interior column:

$$\text{Nominal shear stress} = \frac{V}{b_0 * d} \quad \text{IS 456:2000 Cl 31.6.2.1}$$

$b_0 = \text{perimeter}$

From IS 456:2000 Cl 36.3.1,

$$T_v \leq k_s T_c ; k_s = (0.5 + \beta_c) \leq 1 \quad \beta_c = L/B$$

Here, $\beta_c = 1$.

So $K_s = 1$

$$\begin{aligned} T_c &= 0.25 \sqrt{f_{ck}} \\ &= 1.37 \end{aligned}$$

So, Nominal shear stress (T_v) should be less than 1.37 N/mm^2

From clause 31.6.1,

Critical section for shear shall be at a distance $d/2$ from the periphery of column.

$$\begin{aligned} b_0 &= 4 * (650 + 840) \\ &= 5960 \text{ mm} \end{aligned}$$

$$d = 740 \text{ mm}$$

Maximum load (V) = 4755.68KN

So,

$$T_v = \frac{4755.68 \times 10^3}{5960 \times 840}$$

$$= 0.9499 \text{ N/mm}^2 < 1.37 \text{ N/mm}^2 \text{ (OK)}$$

Area of steel:

Minimum area of steel = 0.12% of Bd

IS 456:2000 Cl 26.5.2.1

$$= 1008 \text{ mm}^2$$

In X direction

c. Area of steel at supports (bottom bars)

IS 456:2000 Annex G

$$M_u = 0.87 \cdot f_y \cdot A_{st} \cdot d \left(1 - \frac{A_{st} \cdot f_y}{b \cdot d \cdot f_{ck}} \right)$$

Here $M_u = 615.27 \text{ KN-m}$

On solving,

$$A_{st} = 1744 \text{ mm}^2 > A_{st}(\text{min})$$

For 20mm bars

$$A_b = 314.159 \text{ mm}^2$$

Spacing of bars:

$$S_v = \frac{A_b}{A_{st}} \cdot 1000$$

$$= 189.28 \text{ mm}$$

Provide 20mm \emptyset bars at 170mm c/c.

$$A_{st} \text{ provided} = 1848 \text{ mm}^2.$$

d. Area of steel at midspan (top bars)

IS 456:2000 Annex G

$$M_u = 0.87 \cdot f_y \cdot A_{st} \cdot d \left(1 - \frac{A_{st} \cdot f_y}{b \cdot d \cdot f_{ck}} \right)$$

Here $M_u = 512.73 \text{ KN-m}$

On solving,

$$A_{st} = 1444 \text{ mm}^2 > A_{st}(\text{min})$$

For 20mm bars

$$A_b = 314.159 \text{ mm}^2$$

Spacing of bars:

$$S_v = \frac{A_b}{A_{st}} \cdot 1000$$

$$= 229.101\text{mm}$$

Provide 20mm Ø bars at 200mm c/c.

$$A_{st} \text{ provided} = 1570.795 \text{ mm}^2.$$

In Y direction

- a. . Area of steel at supports (bottom bars)

IS 456:2000 Annex G

$$M_u = 0.87 * f_y * A_{st} * d \left(1 - \frac{A_{st} * f_y}{b * d * f_{ck}} \right)$$

$$\text{Here } M_u = 615.27 \text{ KN-m}$$

On solving,

$$A_{st} = 1744 \text{ mm}^2 > A_{st}(\text{min})$$

For 20mm bars

$$A_b = 314.159 \text{ mm}^2$$

Spacing of bars:

$$S_v = \frac{A_b * 1000}{A_{st}}$$

$$= 189.28 \text{ mm}$$

Provide 20mm Ø bars at 170mm c/c.

$$A_{st} \text{ provided} = 1848 \text{ mm}^2.$$

- b. Area of steel at midspan (top bars)

IS 456:2000 Annex G

$$M_u = 0.87 * f_y * A_{st} * d \left(1 - \frac{A_{st} * f_y}{b * d * f_{ck}} \right)$$

$$\text{Here } M_u = 512.73 \text{ KN-m}$$

On solving,

$$A_{st} = 1444 \text{ mm}^2 > A_{st}(\text{min})$$

For 20mm bars

$$A_b = 314.159 \text{ mm}^2$$

Spacing of bars:

$$S_v = \frac{A_b * 1000}{A_{st}}$$

$$= 229.101 \text{ mm}$$

Provide 20mm Ø bars at 200mm c/c.

$$A_{st} \text{ provided} = 1570.795 \text{ mm}^2.$$

Check for development length

$$\text{Bond stress for M30 concrete } (T_{bd}) = 1.5$$

IS 456:2000 Cl 26.2.1.1

$$\begin{aligned}L_d &= \frac{\phi \cdot \sigma}{4 \cdot T_b \cdot d} \\ &= \frac{20 \cdot 0.87 \cdot 500}{4 \cdot 1.6 \cdot 1.5} \\ &= 906.25 \text{ mm}\end{aligned}$$

L_o = effective depth (d) or 12ϕ whichever is greater.

$$= 840 \text{ mm}$$

$$\begin{aligned}1.3M_1/V &= \frac{1.3 \cdot 615.65}{4755.68} \\ &= 168.29 \text{ mm}\end{aligned}$$

$$1.3 \frac{M_1}{V} + L_o = 1008.29 > L_D . \text{ Hence OK}$$

Load transfer from column to footing

$$\begin{aligned}\text{Nominal bearing stress in column} &= \frac{P}{A} \\ &= \frac{4755.68 \cdot 10^3}{650 \cdot 650} \\ &= 11.25 \text{ N/mm}^2\end{aligned}$$

$$\begin{aligned}\text{Permissible bearing stress} &= 0.45 \cdot f_{ck} \\ &= 0.45 \cdot 30 \\ &= 13.5 \text{ N/mm}^2 > \text{nominal stress}\end{aligned}$$

So,

No need to provide dowel bars to transfer column load.

Since footing thickness is less than 1m, there is no need to provide side reinforcement.

Chair bars

As per SP 34, suggested spacing of chair bars is 30 times its diameter with at least 12 mm as its diameter. Providing 16mm chair bars @ 480mm c/c.

From manual design:

Along X direction, provide 20 mm ϕ bars @ 170 mm c/c at supports and @ 200 mm c/c at midspan.

Along Y direction, provide 20 mm ϕ bars @ 170 mm c/c at supports and @ 200 mm c/c at midspan.

Chair bars 16 mm @ 480 mm c/c

7.9 Design of Ramp Slab

Upper Basement Slab

Concrete grade = M30

Calculation:

Known values:

Overall depth of slab (D) = 300mm (D > 125mm for earthquake resistant design)

Clear long span = 6.5 – 0.35 = 6.15m

Clear short span = 5.78 – 0.35 = 5.43m

Diameter of bar Φ = 10mm

Effective depth (d) = 300 – 15 – 10/2 = 280mm

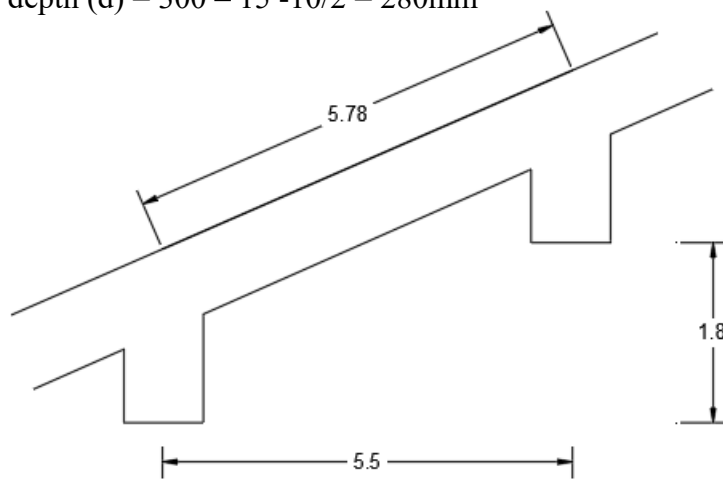

Figure 19: Ramp Dimensions

Effective Length Calculation (IS 456:2000 Cl. 22.2.B.1)

L_x = Lesser of (5.43 + 0.28) and (5.43 + 0.35)

= 5.71m

L_y = Lesser of (6.15 + 0.28) and (6.15 + 0.35)

= 6.43m

L_y/L_x = 6.43/5.71 = 1.12 (<2: two-way slab)

Load Calculation

Dead load = (25*0.3) = 7.5 kN/m²

Floor finish = 1 kN/m²

Live load = 5 kN/m²

Total factored load = 20.25 kN/m²

Since it is a two-way slab with two short edges discontinuous, type 5.

$$\alpha_{x(-)} = 0.04976 \quad (\text{Negative moment at edge})$$

$$\alpha_{x(+)} = 0.0376 \quad (\text{Positive moment at mid-span})$$

$$\alpha_{y(+)} = 0.035 \quad (\text{Positive moment at mid-span})$$

$$M = \alpha * w * l_x^2$$

$$M_x (+ve) = 24.82 \text{ kNm}$$

$$M_x (-ve) = 32.85 \text{ kNm}$$

$$M_y (+ve) = 23.1 \text{ kNm}$$

$$V_x = w * l_x / 2$$

$$= 57.81375 \text{ kN}$$

Tensile Steel Calculation

$$M = 0.36 * f_{ck} * b * x_{u,lim} * (d_{bal} - 0.416 x_{u,lim})$$

Where,

$$M = 32.85 \text{ kNm}$$

$$f_{ck} = 30 \text{ MPa}$$

$$b = 1000 \text{ mm}$$

$$x_{u,lim} = 0.46 * d_{bal}$$

$$d_{bal} = 90.532 \text{ mm} (< 280 \text{ mm ok}) \text{ Now,}$$

$$M = 0.87 * f_y * A_{st} * (1 - 0.416 * x_u)$$

$$\text{For } M_{x+ve} = 24.82 \text{ kNm}$$

$$A_{st,x+} = 206.31 \text{ mm}^2$$

$$\text{For } M_{x-ve} = 32.85 \text{ kNm}$$

$$A_{st,x+} = 274.18 \text{ mm}^2$$

$$\text{For } M_{y+ve} = 23.1 \text{ kNm}$$

$$A_{st,y+} = 191.84 \text{ mm}^2$$

$$A_{st,min} = 0.12\% \text{ of } bD = 360 \text{ mm}^2$$

Maximum spacing of bars should be less than i. $3d = 3 * 280 = 840 \text{ mm}$

ii. 300 mm

Take spacing = 150 mm , for all cases.

$$A_{st,provided} = 314.159 \text{ mm}^2$$

In X-direction:

Provide 10 mm diameter bars @ 250 mm c/c in mid-span

Provide 10 mm diameter bars @ 250 mm c/c in edge

In Y-direction:

Provide 10mm diameter bars @ 250mm c/c in mid-span

Check for shear

Maximum shear force = 57.813 kN

$K = 1$ (from IS 456:2000 cl 40.2.1.1)

% steel = 0.12

$\tau_c = 0.29$

Shear capacity = 81.2 kN (> max SF)

Check for deflection (IS 456:2000 cl.23.2.1)

$\alpha = 26$

$\beta = 1$ (for spans < 10m)

for γ

$f_s = 190.44$

% tension reinforcement = 0.12

$\gamma = 2$

$\delta = 1$

$\lambda = 1$

Provided L/D = 19

Maximum allowable L/D = $\alpha * \beta * \gamma * \delta * \lambda = 52$ (ok)

Check for development length (IS 456:2000 cl.26.2)

$L_d = 0.87 f_y \phi / (4 \tau_{bd}) = 0.87 * 500 * 10 / (4 * 1.5 * 1.6) = 453.125 \text{ mm}$

$M1 = 0.87 f_y A_{st} (d - 0.416 x_u)$

where $x_u = 0.87 f_y A_{st} / (0.36 f_{ck} b)$

$M1 = 0.87 * 500 * (314.159/2) * (280 - 0.416 * x_u)$
= 19 kNm

$V = 57.813 \text{ kN}$

$1.3 M1 / V = 427.23 \text{ mm}$

Providing anchorage of $8\phi = 80 \text{ mm}$

$1.3 M1 / V + L_o = 507.23 \text{ mm} (> 453.125 \text{ mm}) \text{ ok}$

CONCLUSION

With such a high susceptibility to the impact of earthquakes, it is indispensable to make sure that a building designed for Nepal must be such that it ensures adequate safety for both human lives as well as the structure. For this purpose, relevant earthquake-resistant design and ductile detailing must be incorporated. We have completed the project based on the earthquake-resistant design codes (IS 1893) and ductile detailing code (IS 13920), with an attempt to provide adequate safety to the adopted building. Over the course of the completion of the project, we believe to have known better about the mechanism of transfer of lateral earthquake load to the vertical members, and finally to the foundation. Our learnings are not limited to this but extend beyond being able to work efficiently with structural analysis software, enhancing our knowledge regarding the design of buildings based on IS codes, and broadening our horizon regarding structural analysis and design aspects.

With a collective team effort, we have idealized, analyzed, and designed the building to our best ability, under the guidance of our respected supervisor. We are hopeful that the design meets the expectations set on us by our respected supervisor, as well as other faculties and friends, who have in one way or the other, helped us throughout the course of the project.

REFERENCES

Jain, A.K., (2002), *Reinforced Concrete Limit State Design*, 6th Edition.

Varghese, P.C., (1999), *Limit State Design of Reinforced Concrete*.

Pillai, S. Unnilkrishna, M. Devdas, *Reinforced Concrete Design*, 3rd Edition.

ANNEX A

Reinforcement Summary of All Beams
Building 2:

ANNEX A

Floor	Location	Reinforcement detailing for ground floor beam							
		Bottom reinforcement			Top reinforcement			Shear reinforcement	
		Area required	Bars adopted	Area provided	Bars adopted	Area provided	Area provided	Spacing adopted	
A4B4	Left	343	2-20mm Ø	628.31	692	2-25mm Ø	981.74	157.08	200
	Mid	102	2-20mm Ø	628.31	43	2-20mm Ø	628.31	157.08	300
	Right	450	2-20mm Ø	628.31	600	2-25mm Ø	981.74	157.08	200
B4C4	Left	182.5	2-20mm Ø	628.31	365	2-20mm Ø	628.31	157.08	300
	Mid	237	2-20mm Ø	628.31	118.5	2-20mm Ø	628.31	157.08	300
	Right	226	2-20mm Ø	628.31	373	2-20mm Ø	628.31	157.08	300
C4D4	Left	335	2-20mm Ø	628.31	670	2-25mm Ø	981.74	157.08	250
	Mid	235	2-20mm Ø	628.31	117.5	2-20mm Ø	628.31	157.08	300
	Right	343	2-20mm Ø	628.31	687	2-25mm Ø	981.74	157.08	250
D4E4	Left	386	2-20mm Ø	628.31	771	2-25mm Ø	981.74	157.08	200
	Mid	403	2-20mm Ø	628.31	202	2-20mm Ø	628.31	157.08	300
	Right	428.5	2-20mm Ø	628.31	857	2-25mm Ø	981.74	157.08	200

Beam	Location	Reinforcement detailing for first floor beam									
		Bottom reinforcement				Top reinforcement				Shear reinforcement	
		Area required	Bars adopted	Area provided	Bars adopted	Area provided	Area provided	Spacing adopted			
A4B4	Left	1250	3-25mm Ø	1472.62	1714	4-25mm Ø	1963.49	157.08	110		
	Mid	157	2-25mm Ø	981.74	78	2-25mm Ø	981.74	157.08	300		
	Right	1293	3-25mm Ø	1472.62	1457	4-25mm Ø	1963.49	157.08	110		
B4C4	Left	873	2-25mm Ø	981.74	1203	3-25mm Ø	1472.62	157.08	200		
	Mid	204	2-25mm Ø	981.74	102	2-25mm Ø	981.74	157.08	300		
	Right	971	2-25mm Ø	981.74	1340	3-25mm Ø	1472.62	157.08	200		
C4D4	Left	831	2-25mm Ø	981.74	1374	3-25mm Ø	1472.62	157.08	150		
	Mid	326	2-25mm Ø	981.74	192	2-25mm Ø	981.74	157.08	300		
	Right	786	2-25mm Ø	981.74	1360	3-25mm Ø	1472.62	157.08	150		
D4E4	Left	695	2-25mm Ø	981.74	1389	4-25mm Ø	1963.49	157.08	200		
	Mid	398	2-25mm Ø	981.74	200	2-25mm Ø	981.74	157.08	300		
	Right	783	2-25mm Ø	981.74	1566	4-25mm Ø	1963.49	157.08	200		

Beam	Location	Reinforcement detailing for third floor beam							
		Bottom reinforcement			Top reinforcement			Shear reinforcement	
		Area required	Bars adopted	Area provided	Bars adopted	Area provided	Area provided	Spacing adopted	
A4B4	Left	1355	3-25mm Ø	1472.62	1914	4-25mm Ø	1963.49	157.08	100
	Mid	261	2-25mm Ø	981.74	176	2-25mm Ø	981.74	157.08	300
	Right	1452	3-25mm Ø	1472.62	1561	4-25mm Ø	1963.49	157.08	100
B4C4	Left	856	3-25mm Ø	1472.62	1180	3-25mm Ø	1472.62	157.08	200
	Mid	212	2-25mm Ø	981.74	192	2-25mm Ø	981.74	157.08	300
	Right	812	3-25mm Ø	1472.62	1143	3-25mm Ø	1472.62	157.08	200
C4D4	Left	985	3-25mm Ø	1472.62	1516	4-25mm Ø	1963.49	157.08	180
	Mid	255	2-25mm Ø	981.74	212	2-25mm Ø	981.74	157.08	300
	Right	917	3-25mm Ø	1472.62	1526	4-25mm Ø	1963.49	157.08	180
D4E4	Left	695	3-25mm Ø	1472.62	1413	4-25mm Ø	1963.49	157.08	120
	Mid	398	2-25mm Ø	981.74	253	2-25mm Ø	981.74	157.08	300
	Right	783	3-25mm Ø	1472.62	1677	4-25mm Ø	1963.49	157.08	120

Beam	Location	Reinforcement detailing for fourth floor beam							
		Bottom reinforcement			Top reinforcement			Shear reinforcement	
		Area required	Bars adopted	Area provided	Bars adopted	Area provided	Area provided	Spacing adopted	
A4B4	Left	1203	3-25mm Ø	1472.62	1771	4-25mm Ø	1963.49	157.08	100
	Mid	326	2-25mm Ø	981.74	251	2-25mm Ø	981.74	157.08	300
	Right	1316	3-25mm Ø	1472.62	1403	4-25mm Ø	1963.49	157.08	100
B4C4	Left	692	2-25mm Ø	981.74	1002	3-25mm Ø	1472.62	157.08	200
	Mid	173	2-25mm Ø	981.74	138	2-25mm Ø	981.74	157.08	300
	Right	411	2-25mm Ø	981.74	554	3-25mm Ø	1472.62	157.08	200
C4D4	Left	899	2-25mm Ø	981.74	1418	3-25mm Ø	1472.62	157.08	220
	Mid	223	2-25mm Ø	981.74	110	2-25mm Ø	981.74	157.08	300
	Right	843	2-25mm Ø	981.74	1427	3-25mm Ø	1472.62	157.08	220
D4E4	Left	671	2-25mm Ø	981.74	1288	4-25mm Ø	1963.49	157.08	120
	Mid	370	2-25mm Ø	981.74	173	2-25mm Ø	981.74	157.08	300
	Right	591	2-25mm Ø	981.74	1570	4-25mm Ø	1963.49	157.08	120

Beam	Location	Reinforcement detailing for fifth floor beam							
		Bottom reinforcement			Top reinforcement			Shear reinforcement	
		Area required	Bars adopted	Area provided	Bars adopted	Area provided	Area provided	Spacing adopted	
A4B4	Left	940	3-25mm Ø	1472.62	1601	4-25mm Ø	1963.49	157.08	100
	Mid	173	2-25mm Ø	981.74	125	2-25mm Ø	981.74	157.08	300
	Right	1070	3-25mm Ø	1472.62	1200	3-25mm Ø	1472.62	157.08	100
B4C4	Left	472	2-25mm Ø	981.74	780	3-25mm Ø	1472.62	157.08	300
	Mid	173	2-25mm Ø	981.74	105	2-25mm Ø	981.74	157.08	300
	Right	279	2-25mm Ø	981.74	415	3-25mm Ø	1472.62	157.08	300
C4D4	Left	748	2-25mm Ø	981.74	1260	3-25mm Ø	1472.62	157.08	200
	Mid	251	2-25mm Ø	981.74	125	2-25mm Ø	981.74	157.08	300
	Right	692	2-25mm Ø	981.74	1283	3-25mm Ø	1472.62	157.08	200
D4E4	Left	601	2-25mm Ø	981.74	1203	3-25mm Ø	1472.62	157.08	100
	Mid	472	2-25mm Ø	981.74	251	2-25mm Ø	981.74	157.08	300
	Right	748	2-25mm Ø	981.74	1496	4-25mm Ø	1963.49	157.08	100

Beam	Location	Reinforcement detailing for sixth floor beam							
		Bottom reinforcement			Top reinforcement			Shear reinforcement	
		Area required	Bars adopted	Area provided	Bars adopted	Area provided	Area provided	Spacing adopted	
A4B4	Left	646	2-25mm Ø	981.74	1278	3-25mm Ø	1472.62	157.08	120
	Mid	173	2-25mm Ø	981.74	105	2-25mm Ø	981.74	157.08	300
	Right	799	2-25mm Ø	981.74	895	3-25mm Ø	1472.62	157.08	120
B4C4	Left	266	2-25mm Ø	981.74	533	2-25mm Ø	981.74	157.08	300
	Mid	153	2-25mm Ø	981.74	95	2-25mm Ø	981.74	157.08	300
	Right	246	2-25mm Ø	981.74	492	2-25mm Ø	981.74	157.08	300
C4D4	Left	537	2-25mm Ø	981.74	1020	3-25mm Ø	1472.62	157.08	200
	Mid	251	2-25mm Ø	981.74	115	2-25mm Ø	981.74	157.08	300
	Right	524	2-25mm Ø	981.74	1043	3-25mm Ø	1472.62	157.08	200
D4E4	Left	334	2-25mm Ø	981.74	878	3-25mm Ø	1472.62	157.08	120
	Mid	378	2-25mm Ø	981.74	219	2-25mm Ø	981.74	157.08	300
	Right	177	2-25mm Ø	981.74	1185	3-25mm Ø	1472.62	157.08	120

Beam	Location	Reinforcement detailing for top floor beam							
		Bottom reinforcement			Top reinforcement			Shear reinforcement	
		Area required	Bars adopted	Area provided	Area provided	Bars adopted	Area provided	Area provided	Spacing adopted
A4B4	Left	435	2-25mm \emptyset	981.74	865	2-25mm \emptyset	981.74	157.08	180
	Mid	135	2-25mm \emptyset	981.74	122	2-25mm \emptyset	981.74	157.08	300
	Right	555	2-25mm \emptyset	981.74	595	2-25mm \emptyset	981.74	157.08	180
B4C4	Left	246	2-25mm \emptyset	981.74	492	2-25mm \emptyset	981.74	157.08	300
	Mid	173	2-25mm \emptyset	981.74	57	2-25mm \emptyset	981.74	157.08	300
	Right	195	2-25mm \emptyset	981.74	390	2-25mm \emptyset	981.74	157.08	300
C4D4	Left	422	2-25mm \emptyset	981.74	843	2-25mm \emptyset	981.74	157.08	250
	Mid	259	2-25mm \emptyset	981.74	130	2-25mm \emptyset	981.74	157.08	300
	Right	450	2-25mm \emptyset	981.74	900	2-25mm \emptyset	981.74	157.08	250
D4E4	Left	360	2-25mm \emptyset	981.74	713	2-25mm \emptyset	981.74	157.08	220
	Mid	330	2-25mm \emptyset	981.74	173	2-25mm \emptyset	981.74	157.08	300
	Right	452	2-25mm \emptyset	981.74	904	2-25mm \emptyset	981.74	157.08	220

Reinforcement Summary of All Beams
Building 1:

Floor	Location	Reinforcement detailing for upper basement beam							
		Bottom reinforcement			Top reinforcement			Shear reinforcement	
		Area required	Bars adopted	Area provided	Bars adopted	Area provided	Area provided	Spacing adopted	
A2B2	Left	195	2-25mm Ø	981.74	390	2-25mm Ø	981.74	157.08	300
	Mid	243	2-25mm Ø	981.74	122	2-25mm Ø	981.74	157.08	300
	Right	195	2-25mm Ø	981.74	390	2-25mm Ø	981.74	157.08	300
B2C2	Left	344	2-25mm Ø	981.74	688	2-25mm Ø	981.74	157.08	150
	Mid	504	2-25mm Ø	981.74	205	2-25mm Ø	981.74	157.08	300
	Right	390	2-25mm Ø	981.74	765	2-25mm Ø	981.74	157.08	150
C2D2	Left	348	2-25mm Ø	981.74	696	2-25mm Ø	981.74	157.08	200
	Mid	476	2-25mm Ø	981.74	238	2-25mm Ø	981.74	157.08	300
	Right	382	2-25mm Ø	981.74	761	2-25mm Ø	981.74	157.08	200

Floor	Location	Reinforcement detailing for ground floor beam							
		Bottom reinforcement			Top reinforcement			Shear reinforcement	
		Area required	Bars adopted	Area provided	Bars adopted	Area provided	Area provided	Spacing adopted	
A2B2	Left	998	3-25mm Ø	1472.62	1776	4-25mm Ø	1963.48	157.08	100
	Mid	541	2-25mm Ø	981.74	255	2-25mm Ø	981.74	157.08	300
	Right	931	3-25mm Ø	1472.62	1647	4-25mm Ø	1963.48	157.08	100
B2C2	Left	948	3-25mm Ø	1472.62	1546	4-25mm Ø	1963.48	157.08	150
	Mid	459	2-25mm Ø	981.74	250	2-25mm Ø	981.74	157.08	300
	Right	895	3-25mm Ø	1472.62	1606	4-25mm Ø	1963.48	157.08	150
C2D2	Left	940	3-25mm Ø	1472.62	1546	4-25mm Ø	1963.48	157.08	100
	Mid	554	2-25mm Ø	981.74	371	2-25mm Ø	981.74	157.08	300
	Right	891	3-25mm Ø	1472.62	1866	4-25mm Ø	1963.48	157.08	100

Floor	Location	Reinforcement detailing for first floor beam							
		Bottom reinforcement			Top reinforcement			Shear reinforcement	
		Area required	Bars adopted	Area provided	Bars adopted	Area provided	Area provided	Spacing adopted	
A2B2	Left	1245	3-25mm Ø	1472.62	2091	5-25mm Ø	2454.36	157.08	100
	Mid	529	2-25mm Ø	981.74	275	2-25mm Ø	981.74	157.08	300
	Right	1213	3-25mm Ø	1472.62	1963	5-25mm Ø	2454.36	157.08	100
B2C2	Left	1264	3-25mm Ø	1472.62	1861	5-25mm Ø	2454.36	157.08	130
	Mid	455	2-25mm Ø	981.74	253	2-25mm Ø	981.74	157.08	300
	Right	1199	3-25mm Ø	1472.62	2257	5-25mm Ø	2454.36	157.08	130

C2D2	Left	1264	3-25mm \emptyset	1472.62	1877	5-25mm \emptyset	2454.36	157.08	100	
	Mid	554	2-25mm \emptyset	981.74	270	2-25mm \emptyset	981.74	157.08	300	
	Right	1185	3-25mm \emptyset	1472.62	2269	5-25mm \emptyset	2454.36	157.08	100	

Floor	Location	Reinforcement detailing for third floor beam							
		Bottom reinforcement			Top reinforcement			Shear reinforcement	
		Area required	Bars adopted	Area provided	Bars adopted	Area provided	Area provided	Spacing adopted	
A2B2	Left	1070	3-25mm \emptyset	1472.62	2176	5-25mm \emptyset	2454.36	157.08	100
	Mid	604	2-25mm \emptyset	981.74	411	2-25mm \emptyset	981.74	157.08	300
	Right	1052	3-25mm \emptyset	1472.62	2024	5-25mm \emptyset	2454.36	157.08	100
B2C2	Left	1138	3-25mm \emptyset	1472.62	1882	5-25mm \emptyset	2454.36	157.08	130
	Mid	463	2-25mm \emptyset	981.74	374	2-25mm \emptyset	981.74	157.08	300
	Right	1070	3-25mm \emptyset	1472.62	2002	5-25mm \emptyset	2454.36	157.08	130
C2D2	Left	1134	3-25mm \emptyset	1472.62	1855	5-25mm \emptyset	2454.36	157.08	100
	Mid	562	2-25mm \emptyset	981.74	295	2-25mm \emptyset	981.74	157.08	300
	Right	1029	3-25mm \emptyset	1472.62	2287	5-25mm \emptyset	2454.36	157.08	100

Floor	Location	Reinforcement detailing for fourth floor beam							
		Bottom reinforcement			Top reinforcement			Shear reinforcement	
		Area required	Bars adopted	Area provided	Bars adopted	Area provided	Area provided	Spacing adopted	
A2B2	Left	948	3-25mm \emptyset	1472.62	1797	4-25mm \emptyset	1963.48	157.08	120
	Mid	447	2-25mm \emptyset	981.74	447	2-25mm \emptyset	981.74	157.08	300
	Right	962	3-25mm \emptyset	1472.62	962	4-25mm \emptyset	1963.48	157.08	120
B2C2	Left	1016	3-25mm \emptyset	1472.62	1576	4-25mm \emptyset	1963.48	157.08	150
	Mid	386	2-25mm \emptyset	981.74	157	2-25mm \emptyset	981.74	157.08	300
	Right	948	3-25mm \emptyset	1472.62	1683	4-25mm \emptyset	1963.48	157.08	150
C2D2	Left	1011	3-25mm \emptyset	1472.62	1536	4-25mm \emptyset	1963.48	157.08	120
	Mid	472	2-25mm \emptyset	981.74	263	2-25mm \emptyset	981.74	157.08	300
	Right	873	3-25mm \emptyset	1472.62	1952	4-25mm \emptyset	1963.48	157.08	120

Floor	Location	Reinforcement detailing for fifth floor beam							
		Bottom reinforcement			Top reinforcement			Shear reinforcement	
		Area required	Bars adopted	Area provided	Bars adopted	Area provided	Area provided	Spacing adopted	
A2B2	Left	646	2-25mm \emptyset	981.74	1561	4-25mm \emptyset	1963.48	157.08	120
	Mid	533	2-25mm \emptyset	981.74	390	2-25mm \emptyset	981.74	157.08	300
	Right	663	2-25mm \emptyset	981.74	1413	4-25mm \emptyset	1963.48	157.08	120

B2C2	Left	716	2-25mm \emptyset	981.74	1432	4-25mm \emptyset	1963.48	157.08	130	
	Mid	492	2-25mm \emptyset	981.74	246	2-25mm \emptyset	981.74	157.08	300	
	Right	778	2-25mm \emptyset	981.74	1556	4-25mm \emptyset	1963.48	157.08	130	
C2D2	Left	708	2-25mm \emptyset	981.74	1516	4-25mm \emptyset	1963.48	157.08	100	
	Mid	621	2-25mm \emptyset	981.74	290	2-25mm \emptyset	981.74	157.08	300	
	Right	947	2-25mm \emptyset	981.74	1893	4-25mm \emptyset	1963.48	157.08	100	

Floor	Location	Reinforcement detailing for sixth floor beam							
		Bottom reinforcement			Top reinforcement			Shear reinforcement	
		Area required	Bars adopted	Area provided	Bars adopted	Area provided	Area provided	Spacing adopted	
A2B2	Left	590	2-25mm \emptyset	981.74	1180	3-25mm \emptyset	1472.62	157.08	120
	Mid	537	2-25mm \emptyset	981.74	255	2-25mm \emptyset	981.74	157.08	300
	Right	490	2-25mm \emptyset	981.74	971	3-25mm \emptyset	1472.62	157.08	120
B2C2	Left	502	2-25mm \emptyset	981.74	1002	3-25mm \emptyset	1472.62	157.08	150
	Mid	451	2-25mm \emptyset	981.74	271	2-25mm \emptyset	981.74	157.08	300
	Right	526	2-25mm \emptyset	981.74	1052	3-25mm \emptyset	1472.62	157.08	150
C2D2	Left	461	2-25mm \emptyset	981.74	922	3-25mm \emptyset	1472.62	157.08	120
	Mid	550	2-25mm \emptyset	981.74	350	2-25mm \emptyset	981.74	157.08	300
	Right	630	2-25mm \emptyset	981.74	1250	3-25mm \emptyset	1472.62	157.08	120

Floor	Location	Reinforcement detailing for top floor beam							
		Bottom reinforcement			Top reinforcement			Shear reinforcement	
		Area required	Bars adopted	Area provided	Bars adopted	Area provided	Area provided	Spacing adopted	
A2B2	Left	402	2-25mm \emptyset	981.74	804	2-25mm \emptyset	981.74	157.08	180
	Mid	407	2-25mm \emptyset	981.74	204	2-25mm \emptyset	981.74	157.08	300
	Right	340	2-25mm \emptyset	981.74	679	2-25mm \emptyset	981.74	157.08	180
B2C2	Left	360	2-25mm \emptyset	981.74	705	2-25mm \emptyset	981.74	157.08	250
	Mid	342	2-25mm \emptyset	981.74	161	2-25mm \emptyset	981.74	157.08	300
	Right	370	2-25mm \emptyset	981.74	735	2-25mm \emptyset	981.74	157.08	250
C2D2	Left	330	2-25mm \emptyset	981.74	658	2-25mm \emptyset	981.74	157.08	180
	Mid	398	2-25mm \emptyset	981.74	212	2-25mm \emptyset	981.74	157.08	300
	Right	417	2-25mm \emptyset	981.74	834	2-25mm \emptyset	981.74	157.08	180

Detailed Slab Design
Building 2:

Label	lx	ly	lex	ley	ley/lex	D(mm)	Case	Design loa	αx-	αx+	αy-	αy+	Mx-	Mx+	My-	My+	M(max)	d(reqd)	Check
S1	4	6	3.65	5.76	1.578082	150	4	13.125	0.077	0.057	0.047	0.035	13.46405	9.966895	8.218317	6.120023	13.46405	58.09001	OK
S2	4	4.5	3.656	4.15	1.13512	150	3	13.125	0.0464	0.0348	0.037	0.028	8.140099	6.105074	6.491027	4.912128	8.140099	45.16774	OK
S3	4	5.5	3.65	5.26	1.441096	150	3	13.6875	0.0646	0.0486	0.037	0.028	11.77992	8.862294	6.747014	5.105848	11.77992	54.33563	OK
S4	4	5.5	3.65	5.26	1.441096	150	4	13.6875	0.0726	0.0588	0.047	0.035	13.23873	10.72228	8.570531	6.38231	13.23873	57.6019	OK
S5	4.5	4.5	4.15	4.15	1	150	1	13.6875	0.032	0.024	0.032	0.024	7.543455	5.657591	7.543455	5.657591	7.543455	43.48092	OK
S6	4.5	5.5	4.15	5.26	1.26747	150	3	14.625	0.055	0.042	0.037	0.028	13.85335	10.57892	9.319525	7.052614	13.85335	58.92382	OK
S7	4.5	5.5	4.15	5.26	1.26747	150	2	14.625	0.0498	0.0378	0.037	0.028	12.54358	9.521029	9.319525	7.052614	12.54358	56.06919	OK
S8	4.5	5.7	4.15	5.46	1.315663	150	3	14.625	0.0576	0.0443	0.037	0.028	14.50823	11.15824	9.319525	7.052614	14.50823	60.30049	OK
S9	3	5.5	2.65	5.26	1.984906	150	2	14.625	0.0678	0.05168	0.037	0.028	6.963335	5.307746	3.80005	2.875714	6.963335	41.77555	OK
S10	3	5.5	2.65	5.26	1.984906	150	3	14.625	0.084	0.064	0.037	0.028	8.627141	6.57306	3.80005	2.875714	8.627141	46.49936	OK
S11	3	4.5	2.65	4.15	1.566038	150	2	14.625	0.058	0.044	0.037	0.028	5.956836	4.518979	3.80005	2.875714	5.956836	38.6386	OK
S12	3	4.5	2.65	4.15	1.566038	150	4	14.625	0.07716	0.0576	0.047	0.035	7.924645	5.915754	4.827091	3.594642	7.924645	44.56598	OK

Area required					Spacing required				Minm spac	Spacing provided				Area provided			
Astx-	Astx+	Asty-	Asty+	Ast(min)	sx-	sx+	sy-	sy+		sx-	sx+	sy-	sy+	Astx-	Astx+	Asty-	Asty+
245.7029	180.0232	176.5608	130.5463	180	319.6544	436.2772	436.3333	436.3333	300	125	125	125	125	628.32	628.32	628.32	628.32
146.2581	109.0651	138.6335	104.3582	180	436.3333	436.3333	436.3333	436.3333	300	125	125	125	125	628.32	628.32	628.32	628.32
213.8989	159.5632	144.2256	108.5438	180	367.1828	436.3333	436.3333	436.3333	300	125	125	125	125	628.32	628.32	628.32	628.32
241.4287	194.0924	184.3513	136.2615	180	325.3134	404.6527	426.0344	436.3333	300	125	125	125	125	628.32	628.32	628.32	628.32
135.3083	100.9446	161.6878	120.4949	180	436.3333	436.3333	436.3333	436.3333	300	125	125	125	125	628.32	628.32	628.32	628.32
253.1018	191.4174	200.9831	150.9145	180	310.31	410.3076	390.7791	436.3333	300	125	125	125	125	628.32	628.32	628.32	628.32
228.2794	171.7485	200.9831	150.9145	180	344.0521	436.3333	390.7791	436.3333	300	125	125	125	125	628.32	628.32	628.32	628.32
265.5891	202.2413	200.9831	150.9145	180	295.7199	388.3479	390.7791	436.3333	300	125	125	125	125	628.32	628.32	628.32	628.32
124.6979	94.61038	80.43589	60.68657	180	436.3333	436.3333	436.3333	436.3333	300	125	125	125	125	628.32	628.32	628.32	628.32
155.2248	117.5797	80.43589	60.68657	180	436.3333	436.3333	436.3333	436.3333	300	125	125	125	125	628.32	628.32	628.32	628.32
106.3727	80.37475	80.43589	60.68657	180	436.3333	436.3333	436.3333	436.3333	300	125	125	125	125	628.32	628.32	628.32	628.32
142.2997	105.627	102.5226	76.0367	180	436.3333	436.3333	436.3333	436.3333	300	125	125	125	125	628.32	628.32	628.32	628.32

Shear check				Deflection length				Development length					
Shear force	Shear stress	Shear stress	Check	(lex/dx)	α	β	(l/d)modif	Defln check	Devt length	MOR	V(KN)	1.3M/V	Check
23.95313	0.217756	0.29	OK	30.41667	23	2	46	OK	453.125	15.6836	23.95313	851.1909	OK
23.9925	0.218114	0.29	OK	30.46667	23	2	46	OK	453.125	15.6836	23.9925	849.794	OK
24.97969	0.227088	0.29	OK	30.41667	23	2	46	OK	453.125	15.6836	24.97969	816.2105	OK
24.97969	0.227088	0.29	OK	30.41667	23	2	46	OK	453.125	15.6836	24.97969	816.2105	OK
28.40156	0.258196	0.29	OK	34.58333	26	2	52	OK	453.125	15.6836	28.40156	717.8719	OK
30.34688	0.275881	0.29	OK	34.58333	23	2	46	OK	453.125	15.6836	30.34688	671.8545	OK
30.34688	0.275881	0.29	OK	34.58333	23	2	46	OK	453.125	15.6836	30.34688	671.8545	OK
30.34688	0.275881	0.29	OK	34.58333	23	2	46	OK	453.125	15.6836	30.34688	671.8545	OK
19.37813	0.176165	0.29	OK	22.08333	23	2	46	OK	454.125	15.6836	19.37813	1052.149	OK
19.37813	0.176165	0.29	OK	22.08333	23	2	46	OK	455.125	15.6836	19.37813	1052.149	OK
19.37813	0.176165	0.29	OK	22.08333	23	2	46	OK	456.125	15.6836	19.37813	1052.149	OK
19.37813	0.176165	0.29	OK	22.08333	23	2	46	OK	457.125	15.6836	19.37813	1052.149	OK

Building 1:

Label	lx	ly	lex	ley	ley/lex	D(mm)	Case	Design loa	ax-	ax+	ay-	ay+	Mx-	Mx+	My-	My+	M(max)	d(reqd)	Check
S1	3.25	6	2.95	5.78	1.959322	150	4	13.125	0.0896	0.0678	0.047	0.035	10.23414	7.744137	5.368355	3.997711	10.23414	50.64531	OK
S2	3.25	4.5	2.95	4.28	1.450847	150	3	13.125	0.065	0.049	0.037	0.028	7.42432	5.596795	4.226152	3.198169	7.42432	43.1362	OK
S3	3.25	5.5	2.95	5.28	1.789831	150	3	13.125	0.078	0.0597	0.037	0.028	8.909184	6.818953	4.226152	3.198169	8.909184	47.25334	OK
S4	3.25	5.5	2.95	5.28	1.789831	150	4	13.125	0.08484	0.06372	0.047	0.035	9.690451	7.278118	5.368355	3.997711	9.690451	49.28169	OK
S5	3.25	6	2.95	5.78	1.959322	150	2	13.125	0.0672	0.051	0.037	0.028	7.675605	5.825236	4.226152	3.198169	7.675605	43.86012	OK
S6	3.25	4.5	2.95	4.28	1.450847	150	1	13.125	0.052	0.04	0.032	0.024	5.939456	4.568813	3.65505	2.741288	5.939456	38.58219	OK
S7	3.25	5.5	2.95	5.28	1.789831	150	1	13.125	0.0606	0.0456	0.032	0.024	6.921751	5.208446	3.65505	2.741288	6.921751	41.65063	OK
S8	3.25	5.5	2.95	5.28	1.789831	150	2	13.125	0.06448	0.04848	0.037	0.028	7.364926	5.537401	4.226152	3.198169	7.364926	42.96331	OK
S9	3.25	6	2.95	5.78	1.959322	150	2	13.125	0.0672	0.051	0.037	0.028	7.675605	5.825236	4.226152	3.198169	7.675605	43.86012	OK
S10	3.25	4.5	2.95	4.28	1.450847	150	1	13.125	0.052	0.04	0.032	0.024	5.939456	4.568813	3.65505	2.741288	5.939456	38.58219	OK
S11	3.25	5.5	2.95	5.28	1.789831	150	1	13.125	0.0606	0.0456	0.032	0.024	6.921751	5.208446	3.65505	2.741288	6.921751	41.65063	OK
S12	3.25	5.5	2.95	5.28	1.789831	150	2	13.125	0.06448	0.04848	0.037	0.028	7.364926	5.537401	4.226152	3.198169	7.364926	42.96331	OK
S13	3.25	6	2.95	5.78	1.959322	150	2	13.125	0.0672	0.051	0.037	0.028	7.675605	5.825236	4.226152	3.198169	7.675605	43.86012	OK
S14	3.25	4.5	2.95	4.28	1.450847	150	1	13.125	0.052	0.04	0.032	0.024	5.939456	4.568813	3.65505	2.741288	5.939456	38.58219	OK
S15	3.25	5.5	2.95	5.28	1.789831	150	1	13.125	0.0606	0.0456	0.032	0.024	6.921751	5.208446	3.65505	2.741288	6.921751	41.65063	OK
S16	3.25	5.5	2.95	5.28	1.789831	150	2	13.125	0.06448	0.04848	0.037	0.028	7.364926	5.537401	4.226152	3.198169	7.364926	42.96331	OK
S17	3.25	6	2.95	5.78	1.959322	150	5	14.625	0.0682	0.0514	0	0.035	8.680091	6.541887	0	4.454592	8.680091	46.64184	OK
S18	3.25	5.5	2.95	5.28	1.789831	150	2	13.125	0.06448	0.04848	0.037	0.028	7.364926	5.537401	4.226152	3.198169	7.364926	42.96331	OK
S19	3.25	5.5	2.95	5.28	1.789831	150	2	13.125	0.06448	0.04848	0.037	0.028	7.364926	5.537401	4.226152	3.198169	7.364926	42.96331	OK
S20	3.25	6	2.95	5.78	1.959322	150	7	14.625	0.0958	0.0722	0	0.043	12.19286	9.189187	0	5.472785	12.19286	55.27977	OK
S21	3.25	5.5	2.95	5.28	1.789831	150	4	13.125	0.08484	0.06372	0.047	0.035	9.690451	7.278118	5.368355	3.997711	9.690451	49.28169	OK
S22	3.25	5.5	2.95	5.28	1.789831	150	4	13.125	0.08484	0.06372	0.047	0.035	9.690451	7.278118	5.368355	3.997711	9.690451	49.28169	OK

Area required		Spacing required				Minm spac	Spacing provided				Area provided					
Astx-	Astx+	Asty-	Asty+	sx-	sx+	sy-	sy+	sx-	sx+	sy-	sy+	Astx-	Astx+	Asty-	Asty+	
185.476	139.5068	104.4075	77.45605	423.4511	436.3333	436.3333	436.3333	300	125	125	125	125	628.32	628.32	628.32	628.32
133.6432	100.3102	81.93362	61.82919	436.3333	436.3333	436.3333	436.3333	300	125	125	125	125	628.32	628.32	628.32	628.32
160.945	122.5691	81.93362	61.82919	436.3333	436.3333	436.3333	436.3333	300	125	125	125	125	628.32	628.32	628.32	628.32
175.3903	130.9657	104.4075	77.45605	436.3333	436.3333	436.3333	436.3333	300	125	125	125	125	628.32	628.32	628.32	628.32
138.2495	104.4608	81.93362	61.82919	436.3333	436.3333	436.3333	436.3333	300	125	125	125	125	628.32	628.32	628.32	628.32
106.5379	81.68835	70.75035	52.93046	436.3333	436.3333	436.3333	436.3333	300	125	125	125	125	628.32	628.32	628.32	628.32
124.4473	93.2646	70.75035	52.93046	436.3333	436.3333	436.3333	436.3333	300	125	125	125	125	628.32	628.32	628.32	628.32
132.5552	99.23183	81.93362	61.82919	436.3333	436.3333	436.3333	436.3333	300	125	125	125	125	628.32	628.32	628.32	628.32
138.2495	104.4608	81.93362	61.82919	436.3333	436.3333	436.3333	436.3333	300	125	125	125	125	628.32	628.32	628.32	628.32
106.5379	81.68835	70.75035	52.93046	436.3333	436.3333	436.3333	436.3333	300	125	125	125	125	628.32	628.32	628.32	628.32
124.4473	93.2646	70.75035	52.93046	436.3333	436.3333	436.3333	436.3333	300	125	125	125	125	628.32	628.32	628.32	628.32
132.5552	99.23183	81.93362	61.82919	436.3333	436.3333	436.3333	436.3333	300	125	125	125	125	628.32	628.32	628.32	628.32
138.2495	104.4608	81.93362	61.82919	436.3333	436.3333	436.3333	436.3333	300	125	125	125	125	628.32	628.32	628.32	628.32
106.5379	81.68835	70.75035	52.93046	436.3333	436.3333	436.3333	436.3333	300	125	125	125	125	628.32	628.32	628.32	628.32
124.4473	93.2646	70.75035	52.93046	436.3333	436.3333	436.3333	436.3333	300	125	125	125	125	628.32	628.32	628.32	628.32
132.5552	99.23183	81.93362	61.82919	436.3333	436.3333	436.3333	436.3333	300	125	125	125	125	628.32	628.32	628.32	628.32
156.7197	117.5115	0	86.41689	436.3333	436.3333	436.3333	436.3333	300	125	125	125	125	628.32	628.32	628.32	628.32
132.5552	99.23183	81.93362	61.82919	436.3333	436.3333	436.3333	436.3333	300	125	125	125	125	628.32	628.32	628.32	628.32
132.5552	99.23183	81.93362	61.82919	436.3333	436.3333	436.3333	436.3333	300	125	125	125	125	628.32	628.32	628.32	628.32
222.0405	166.1157	0	106.4694	353.7192	436.3333	436.3333	436.3333	300	125	125	125	125	628.32	628.32	628.32	628.32
175.3903	130.9657	104.4075	77.45605	436.3333	436.3333	436.3333	436.3333	300	125	125	125	125	628.32	628.32	628.32	628.32
175.3903	130.9657	104.4075	77.45605	436.3333	436.3333	436.3333	436.3333	300	125	125	125	125	628.32	628.32	628.32	628.32

Shear check				Deflection length				Development length					
Shear force	Shear stress	Shear stress	Check	(lex/dx)	α	β	(l/d)modified	Defln check	Devt length	MOR	V(KN)	1.3M/V	Check
19.35938	0.148918	0.29	ok	22.69231	23	2	46	OK	457.125	15.6836	19.35938	1053.168	OK
19.35938	0.148918	0.29	ok	22.69231	23	2	46	OK	458.125	15.6836	19.35938	1053.168	OK
19.35938	0.148918	0.29	ok	22.69231	23	2	46	OK	459.125	15.6836	19.35938	1053.168	OK
19.35938	0.148918	0.29	ok	22.69231	23	2	46	OK	460.125	15.6836	19.35938	1053.168	OK
19.35938	0.148918	0.29	ok	22.69231	23	2	46	OK	461.125	15.6836	19.35938	1053.168	OK
19.35938	0.148918	0.29	ok	22.69231	26	2	46	OK	462.125	15.6836	19.35938	1053.168	OK
19.35938	0.148918	0.29	ok	22.69231	26	2	46	OK	463.125	15.6836	19.35938	1053.168	OK
19.35938	0.148918	0.29	ok	22.69231	23	2	46	OK	464.125	15.6836	19.35938	1053.168	OK
19.35938	0.148918	0.29	ok	22.69231	26	2	46	OK	465.125	15.6836	19.35938	1053.168	OK
19.35938	0.148918	0.29	ok	22.69231	26	2	46	OK	466.125	15.6836	19.35938	1053.168	OK
19.35938	0.148918	0.29	ok	22.69231	23	2	46	OK	467.125	15.6836	19.35938	1053.168	OK
19.35938	0.148918	0.29	ok	22.69231	26	2	46	OK	468.125	15.6836	19.35938	1053.168	OK
19.35938	0.148918	0.29	ok	22.69231	26	2	46	OK	469.125	15.6836	19.35938	1053.168	OK
19.35938	0.148918	0.29	ok	22.69231	23	2	46	OK	470.125	15.6836	19.35938	1053.168	OK
19.35938	0.148918	0.29	ok	22.69231	23	2	46	OK	471.125	15.6836	19.35938	1053.168	OK
19.35938	0.148918	0.29	ok	22.69231	23	2	46	OK	472.125	15.6836	19.35938	1053.168	OK
21.57188	0.165938	0.29	ok	22.69231	23	2	46	OK	473.125	15.6836	21.57188	945.1512	OK
19.35938	0.148918	0.29	ok	22.69231	23	2	46	OK	474.125	15.6836	19.35938	1053.168	OK
19.35938	0.148918	0.29	ok	22.69231	23	2	46	OK	475.125	15.6836	19.35938	1053.168	OK
21.57188	0.165938	0.29	ok	22.69231	23	2	46	OK	476.125	15.6836	21.57188	945.1512	OK
19.35938	0.148918	0.29	ok	22.69231	23	2	46	OK	477.125	15.6836	19.35938	1053.168	OK
19.35938	0.148918	0.29	ok	22.69231	23	2	46	OK	478.125	15.6836	19.35938	1053.168	OK

Detailed Column Design
Building 2:

ANNEX A

Storey	Column ID	P(KN)	M2(KN-m)	M3(KN-m)	Vmax	Breadth	Depth	Height (H)	H(eff-x)	H(eff-y)	SRx	Sry	Ex	Ey	E(adopted)
1st storey	C15	1921.6	263.47	878	278.21	550	750	3.6	2.773	2.714	5.041818	3.618667	18.33923	25.09833	25.098333
1st storey	C14	1551.03	124.76	1056.08	380.37	550	750	3.6	2.773	2.714	5.041818	3.618667	18.33923	25.09833	25.098333
1st storey	C13	1732	47.55	1041.5	366.3	550	750	3.6	2.773	2.714	5.041818	3.618667	18.33923	25.09833	25.098333
1st storey	C12	1609	104.45	1024.42	350.35	550	750	3.6	2.773	2.714	5.041818	3.618667	18.33923	25.09833	25.098333
1st storey	C11	1376.4	208.56	872.7	252.7	550	750	3.6	2.773	2.714	5.041818	3.618667	18.33923	25.09833	25.098333
1st storey	C10	1648.48	233.56	476.32	125.39	550	750	3.6	2.773	2.714	5.041818	3.618667	18.33923	25.09833	25.098333
1st storey	C16	2347.65	294.78	568.44	180.79	550	750	3.6	2.773	2.714	5.041818	3.618667	18.33923	25.09833	25.098333
1st storey	C23	1520.39	135	656.89	244.37	550	750	3.6	2.773	2.714	5.041818	3.618667	18.33923	25.09833	25.098333
1st storey	C22	1866.71	49.37	617.31	219.27	550	750	3.6	2.773	2.714	5.041818	3.618667	18.33923	25.09833	25.098333
1st storey	C21	1571.1	55.066	586.69	198.6	550	750	3.6	2.773	2.714	5.041818	3.618667	18.33923	25.09833	25.098333
1st storey	C17	1444.6	609.63	52.03	247.55	550	750	3.6	2.773	2.714	5.041818	3.618667	18.33923	25.09833	25.098333
1st storey	C24	1644.56	462.6	62.85	199.1	550	750	3.6	2.773	2.714	5.041818	3.618667	18.33923	25.09833	25.098333
1st storey	C25	1049.6	396.7	3.17	167.205	550	750	3.6	2.773	2.714	5.041818	3.618667	18.33923	25.09833	25.098333
1st storey	C20	2151.49	437.22	52.59	169.48	550	750	3.6	2.773	2.714	5.041818	3.618667	18.33923	25.09833	25.098333
1st storey	C9	1393.92	233.67	387.78	105.02	550	750	3.6	2.773	2.714	5.041818	3.618667	18.33923	25.09833	25.098333
1st storey	C6	1560.6	800.7	49	307.7	650	650	3.6	2.773	2.714	4.266154	4.175385	21.67257	21.765	21.765
1st storey	C7	3631.59	249.3	442.3	183.7	650	650	3.6	2.773	2.714	4.266154	4.175385	21.67257	21.765	21.765
1st storey	C18	4273.72	95.4	457.2	184.4	650	650	3.6	2.773	2.714	4.266154	4.175385	21.67257	21.765	21.765
1st storey	C19	1987.7	147.9	428.2	168.7	650	650	3.6	2.773	2.714	4.266154	4.175385	21.67257	21.765	21.765
1st storey	C8	1412.5	680.2	83.1	267.8	650	650	3.6	2.773	2.714	4.266154	4.175385	21.67257	21.765	21.765
1st storey	C1	1904.25	336.44	562.8	201.45	650	650	3.6	2.773	2.714	4.266154	4.175385	21.67257	21.765	21.765
1st storey	C2	3497.8	113.6	780.5	467.2	650	650	3.6	2.773	2.714	4.266154	4.175385	21.67257	21.765	21.765
1st storey	C3	4199.06	141.16	741.35	389.87	650	650	3.6	2.773	2.714	4.266154	4.175385	21.67257	21.765	21.765
1st storey	C4	1723.11	92	654.6	247.1	650	650	3.6	2.773	2.714	4.266154	4.175385	21.67257	21.765	21.765
1st storey	C5	1410.7	247.5	555.4	176.9	650	650	3.6	2.773	2.714	4.266154	4.175385	21.67257	21.765	21.765

Me(x)	Me(y)	M2(design)	M39(design)	Area	p%	p/fck	Pu/fckbd	mu/fckbd^	mux1	muy1	puz	pu/puz	alpha	Check
35.240671	48.22896	263.47	878	8250	2	0.066667	0.155281	0.17	1157.063	1577.813	8332.5	0.230615	1.05	0.751862
28.444701	38.92827	124.76	1056.08	8250	2	0.066667	0.125336	0.18	1225.125	1670.625	8332.5	0.186142	1	0.733981
31.763552	43.47031	47.55	1041.5	8250	2	0.066667	0.13996	0.17	1157.063	1577.813	8332.5	0.207861	1.01	0.697159
29.507826	40.38322	104.45	1024.42	8250	2	0.066667	0.13002	0.17	1157.063	1577.813	8332.5	0.193099	1	0.739538
25.242121	34.54535	208.56	872.7	8250	2	0.066667	0.111224	0.185	1259.156	1717.031	8332.5	0.165185	1	0.673896
30.231859	41.3741	233.56	476.32	8250	2	0.066667	0.133211	0.16	1089	1485	8332.5	0.197837	1	0.535226
43.054101	58.9221	294.78	568.44	8250	2	0.066667	0.189709	0.17	1157.063	1577.813	8332.5	0.281746	1.13	0.528769

ANNEX A

27.882787	38.15926	135	656.89	8250	2	0.066667	0.12286	0.15	1020.938	1392.188	8332.5	0.182465	1	0.604072
34.23403	46.85131	49.37	617.31	8250	2	0.066667	0.150845	0.16	1089	1485	8332.5	0.224028	1.04	0.441413
28.812769	39.43199	55.066	586.69	8250	2	0.066667	0.126958	0.15	1020.938	1392.188	8332.5	0.188551	1	0.475353
26.492856	36.25705	609.63	52.03	8250	2	0.066667	0.116735	0.16	1089	1485	8332.5	0.173369	1	0.594844
30.15997	41.27572	462.6	62.85	8250	2	0.066667	0.132894	0.16	1089	1485	8332.5	0.197367	1	0.467117
19.248859	26.34321	396.7	26.343211	8250	2	0.066667	0.084816	0.15	1020.938	1392.188	8332.5	0.125965	1	0.390841
39.456677	53.99881	437.22	53.998813	8250	2	0.066667	0.173858	0.17	1157.063	1577.813	8332.5	0.258205	1.09	0.370723
25.563424	34.98507	233.67	387.78	8250	2	0.066667	0.11264	0.16	1089	1485	8332.5	0.167287	1	0.475704
33.822208	33.96646	800.7	49	7816.25	1.85	0.061667	0.123124	0.14	1153.425	1153.425	8467.5	0.184305	1	0.736676
78.705876	79.04156	249.3	442.3	7816.25	1.85	0.061667	0.286516	0.11	906.2625	906.2625	8467.5	0.428886	1.381	0.539567
92.622482	93.01752	95.4	457.2	7816.25	1.85	0.061667	0.337177	0.11	906.2625	906.2625	8467.5	0.50472	1.507	0.390234
43.078561	43.26229	147.9	428.2	7816.25	1.85	0.061667	0.156821	0.12	988.65	988.65	8467.5	0.234745	1.057	0.547188
30.6125	30.74306	680.2	83.1	7816.25	1.85	0.061667	0.111144	0.13	1071.038	1071.038	8467.5	0.166814	1	0.712673
41.269985	41.446	336.44	562.8	7816.25	1.85	0.061667	0.150237	0.135	1112.231	1112.231	8467.5	0.224889	1.04	0.780772
75.806304	76.12962	113.6	780.5	7816.25	1.85	0.061667	0.275961	0.12	988.65	988.65	8467.5	0.413085	1.355	0.779213
91.004408	91.39254	141.16	741.35	7816.25	1.85	0.061667	0.331287	0.11	906.2625	906.2625	8467.5	0.495903	1.49	0.803982
37.344216	37.50349	92	654.6	7816.25	1.85	0.061667	0.135946	0.12	988.65	988.65	8467.5	0.203497	1.01	0.750263
30.57349	30.70389	247.5	555.4	7816.25	1.85	0.061667	0.111298	0.13	1071.038	1071.038	8467.5	0.166602	1	0.749647

Detailed Column Design
Building 1:

Storey	Column ID	P(KN)	M2(KN-m)	M3(KN-m)	Vmax	Breadth	Depth	Height (H)	H(eff-x)	H(eff-y)	SRx	Sry	Ex	Ey	E(adopted)
1st storey	C17	445.61	281.53	87.19	135.41	650	650	3.6	2.773	2.714	4.266154	4.175385	21.67257	21.765	21.765
1st storey	C18	2729.84	94.78	512.23	247.22	650	650	3.6	2.773	2.714	4.266154	4.175385	21.67257	21.765	21.765
1st storey	C19	2640.27	59.73	508.98	245.014	650	650	3.6	2.773	2.714	4.266154	4.175385	21.67257	21.765	21.765
1st storey	C20	670.82	39.32	328.67	156.67	650	650	3.6	2.773	2.714	4.266154	4.175385	21.67257	21.765	21.765
1st storey	C13	541.38	63.8	677.03	197.2	650	650	3.6	2.773	2.714	4.266154	4.175385	21.67257	21.765	21.765
1st storey	C14	3674.57	43.27	740.65	264.25	650	650	3.6	2.773	2.714	4.266154	4.175385	21.67257	21.765	21.765
1st storey	C15	3712.76	49.86	611.29	216.46	650	650	3.6	2.773	2.714	4.266154	4.175385	21.67257	21.765	21.765
1st storey	C16	2878.93	697.95	193.94	257.53	650	650	3.6	2.773	2.714	4.266154	4.175385	21.67257	21.765	21.765
1st storey	C9	1572.84	801.71	35.27	298.18	650	650	3.6	2.773	2.714	4.266154	4.175385	21.67257	21.765	21.765
1st storey	C10	3459.24	80	621.56	221.62	650	650	3.6	2.773	2.714	4.266154	4.175385	21.67257	21.765	21.765
1st storey	C11	4513.29	35.86	580.45	219.73	650	650	3.6	2.773	2.714	4.266154	4.175385	21.67257	21.765	21.765
1st storey	C12	4367.76	813.29	110.32	420.42	650	650	3.6	2.773	2.714	4.266154	4.175385	21.67257	21.765	21.765
1st storey	C6	1610.31	791.68	100.54	288.2	650	650	3.6	2.773	2.714	4.266154	4.175385	21.67257	21.765	21.765
1st storey	C7	3575.42	51.44	594.15	212.96	650	650	3.6	2.773	2.714	4.266154	4.175385	21.67257	21.765	21.765
1st storey	C8	4808.22	37.23	604.09	224.78	650	650	3.6	2.773	2.714	4.266154	4.175385	21.67257	21.765	21.765
1st storey	C5	4335.63	631.33	279.52	322.07	650	650	3.6	2.773	2.714	4.266154	4.175385	21.67257	21.765	21.765
1st storey	C21	486.22	70.49	710.37	205.79	650	650	3.6	2.773	2.714	4.266154	4.175385	21.67257	21.765	21.765
1st storey	C22	3474.89	53.44	839.86	294.11	650	650	3.6	2.773	2.714	4.266154	4.175385	21.67257	21.765	21.765
1st storey	C23	3697.99	46.46	837.98	292.22	650	650	3.6	2.773	2.714	4.266154	4.175385	21.67257	21.765	21.765
1st storey	C24	838.73	68.41	677	196.28	650	650	3.6	2.773	2.714	4.266154	4.175385	21.67257	21.765	21.765

Me(x)	Me(y)	M2(design)	M39design	Area	p%	p/fck	Pu/fckbd	mu/fckbd^	mux1	muy1	puz	pu/puz	alpha	Check
9.657512	9.698702	281.53	87.19	7393.75	1.75	0.058333	0.035157	0.11	906.2625	906.2625	8467.5	0.052626	1	0.406858
59.16264	59.41497	94.78	512.23	7393.75	1.75	0.058333	0.215372	0.12	988.65	988.65	8467.5	0.32239	1.2	0.514243
57.22143	57.46548	59.73	508.98	7393.75	1.75	0.058333	0.208305	0.13	1071.038	1071.038	8467.5	0.311812	1.18	0.448829
14.53839	14.6004	39.32	328.67	7393.75	1.75	0.058333	0.052925	0.11	906.2625	906.2625	8467.5	0.079223	1	0.406052
11.73309	11.78314	63.8	677.03	7393.75	1.75	0.058333	0.042712	0.11	906.2625	906.2625	8467.5	0.063936	1	0.817456
79.63736	79.97702	79.6373633	740.65	7393.75	1.75	0.058333	0.289907	0.11	906.2625	906.2625	8467.5	0.433962	1.38	0.771958
80.46504	80.80822	80.46503862	611.29	7393.75	1.75	0.058333	0.29292	0.11	906.2625	906.2625	8467.5	0.438472	1.38	0.599055
62.3938	62.65991	697.95	193.94	7393.75	1.75	0.058333	0.227135	0.12	988.65	988.65	8467.5	0.339998	1.23	0.786505
34.08748	34.23286	801.71	35.27	7393.75	1.75	0.058333	0.12409	0.115	947.4563	947.4563	8467.5	0.18575	1	0.883397
74.97061	75.29036	80	621.56	7393.75	1.75	0.058333	0.272918	0.115	947.4563	947.4563	8467.5	0.408531	1.33	0.608182
97.81458	98.23176	97.81457841	580.45	7393.75	1.75	0.058333	0.356078	0.1	823.875	823.875	8467.5	0.533013	1.55	0.588863
94.66057	95.0643	813.29	110.32	7393.75	1.75	0.058333	0.344596	0.105	865.0688	865.0688	8467.5	0.515826	1.52	0.954154
34.89955	35.0484	791.68	100.54	7393.75	1.75	0.058333	0.127046	0.115	947.4563	947.4563	8467.5	0.190175	1	0.9417
77.48853	77.81902	77.48852831	594.15	7393.75	1.75	0.058333	0.282084	0.105	865.0688	865.0688	8467.5	0.422252	1.36	0.62147
104.2065	104.6509	104.2064685	604.09	7393.75	1.75	0.058333	0.379347	0.1	823.875	823.875	8467.5	0.567844	1.6	0.615721
93.96423	94.36499	631.33	279.52	7393.75	1.75	0.058333	0.342062	0.1	823.875	823.875	8467.5	0.512032	1.51	0.86451
10.53764	10.58258	70.49	710.37	7393.75	1.75	0.058333	0.038361	0.1	823.875	823.875	8467.5	0.057422	1	0.947789
75.30979	75.63098	75.30978518	839.86	7393.75	1.75	0.058333	0.274153	0.115	947.4563	947.4563	8467.5	0.41038	1.35	0.870434
80.14493	80.48675	80.14493481	837.98	7393.75	1.75	0.058333	0.291755	0.105	865.0688	865.0688	8467.5	0.436727	1.4	0.973111
18.17743	18.25496	68.41	677	7393.75	1.75	0.058333	0.066172	0.115	947.4563	947.4563	8467.5	0.099053	1	0.786749

ANNEX B

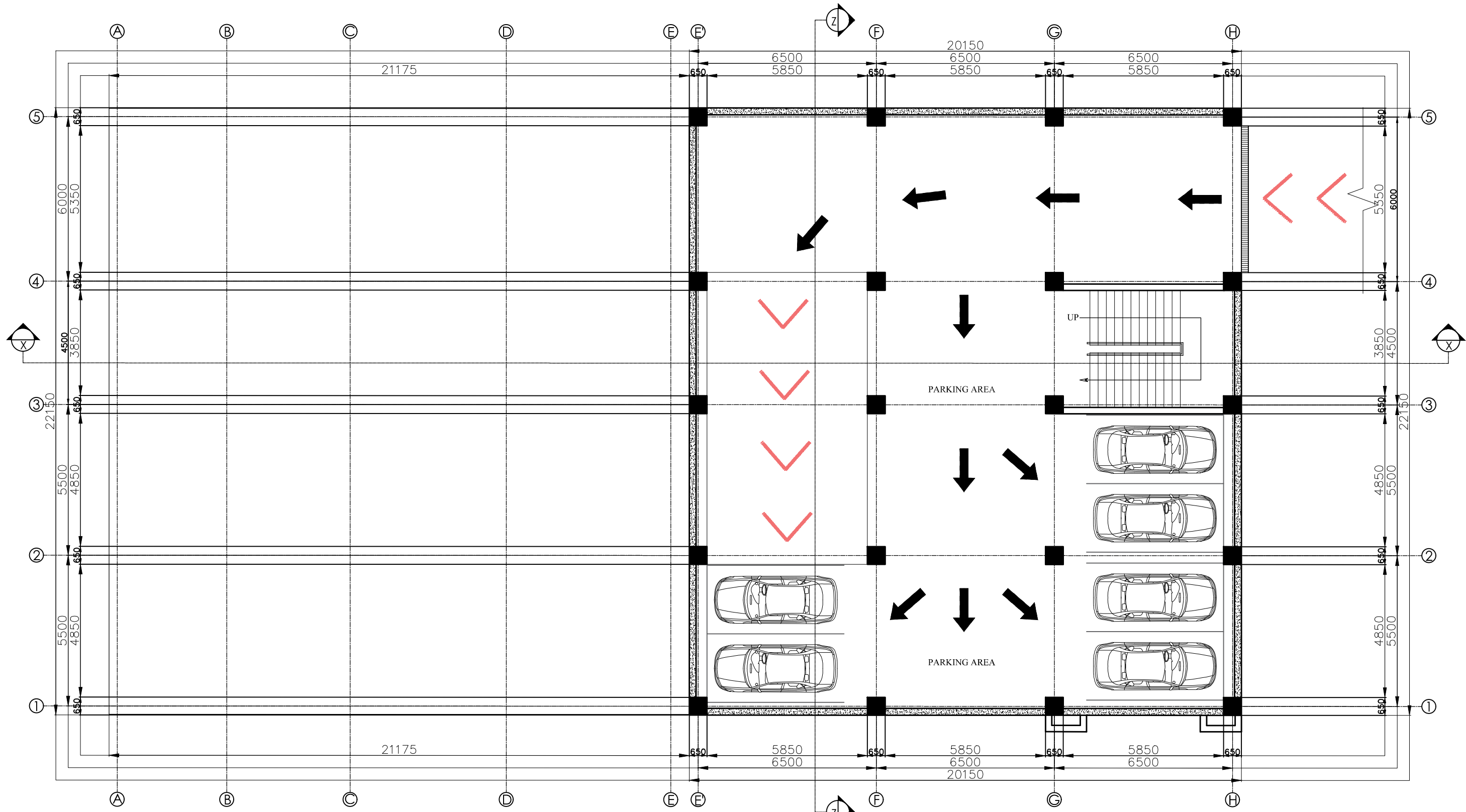

LOWER BASEMENT PLAN
 Area: 444.22 SQ.M.

INSTITUTE OF ENGINEERING PULCHOWK CAMPUS PULCHOWK, LALITPUR	PROJECT TITLE	SHEET TITLE	SUBMITTED TO:	SUBMITTED BY:		SCALE: FIT TO SCALE
	EARTHQUAKE RESISTANT ANALYSIS AND DESIGN OF MULTIPURPOSE BUILDING	Lower Basement Plan	DEPARTMENT OF CIVIL ENGINEERING PULCHOWK CAMPUS	Prakrit Devkota (PUL075BCE101)	Priyanshu Pokhrel (PUL075BCE109)	SHEET NO. 1
				Ram Krishna Kandel (PUL075BCE116)	Rijab Ali Miya (PUL075BCE119)	SUBMISSION DATE:
				Safal Katwal (PUL075BCE129)	Sangam Poudel (PUL075BCE142)	April 2023
			PROJECT SUPERVISOR:	Asst. Prof. Aakarsha Khawas		

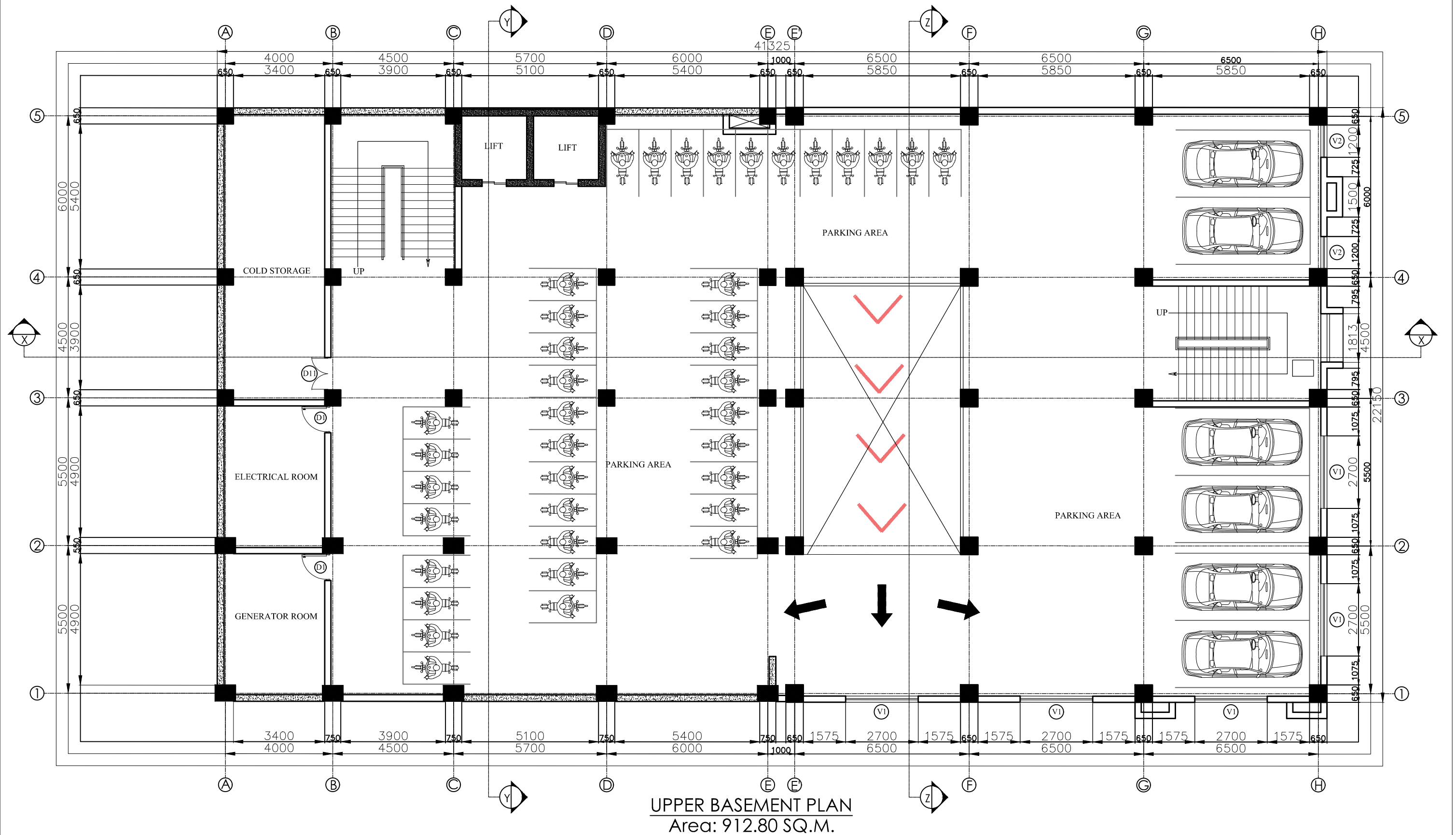

INSTITUTE OF ENGINEERING PULCHOWK CAMPUS PULCHOWK, LALITPUR	PROJECT TITLE	SHEET TITLE	SUBMITTED TO:	SUBMITTED BY:		SCALE: FIT TO SCALE
	EARTHQUAKE RESISTANT ANALYSIS AND DESIGN OF MULTIPURPOSE BUILDING	Upper Basement Plan	DEPARTMENT OF CIVIL ENGINEERING PULCHOWK CAMPUS	Prakrit Devkota (PUL075BCE101)	Priyanshu Pokhrel (PUL075BCE109)	SHEET NO. 2
				Ram Krishna Kandel (PUL075BCE116)	Rijab Ali Miya (PUL075BCE119)	SUBMISSION DATE:
				Safal Katwal (PUL075BCE129)	Sangam Poudel (PUL075BCE142)	April 2023
			PROJECT SUPERVISOR:	Asst. Prof. Aakarsha Khawas		

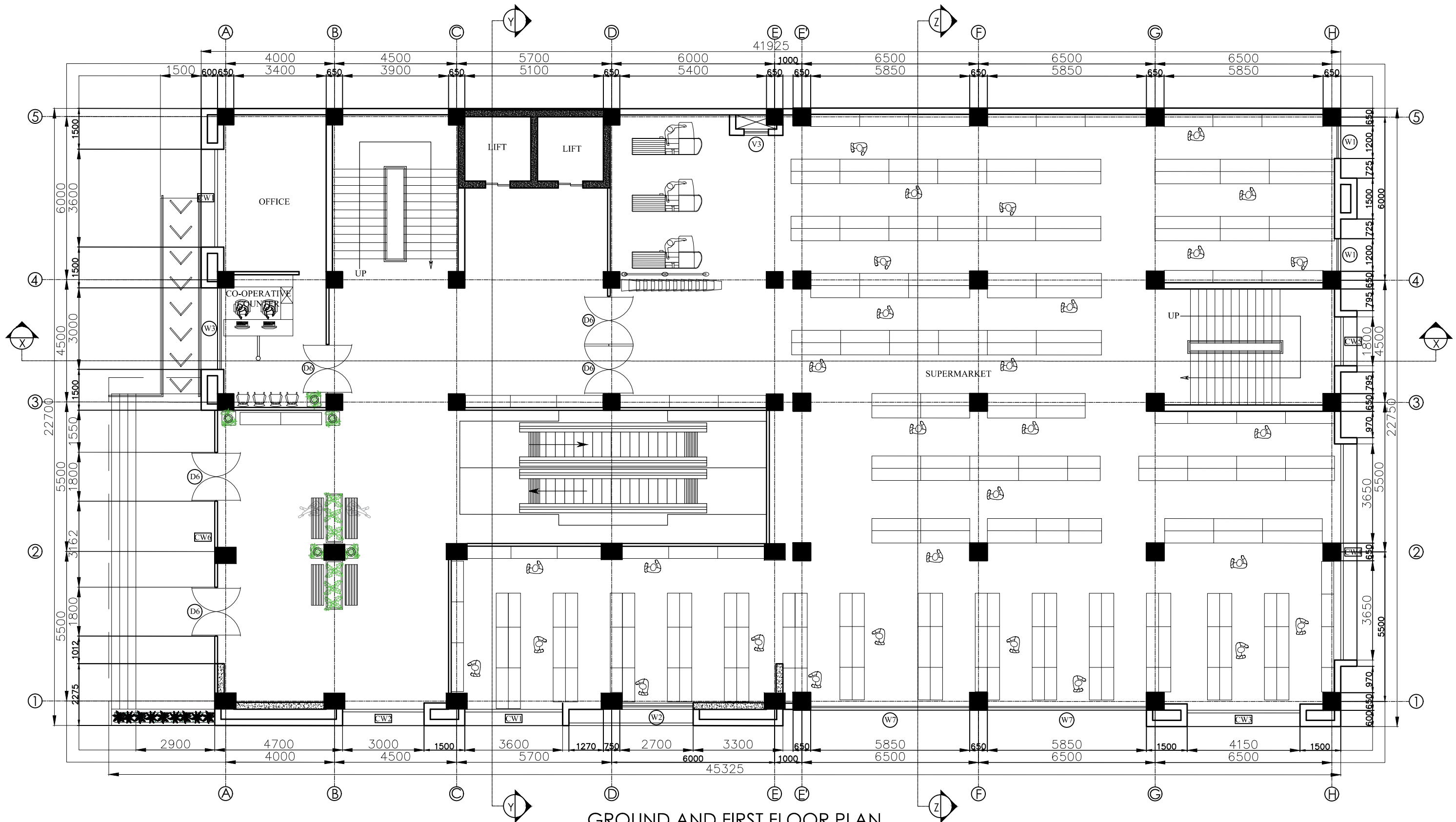

GROUND AND FIRST FLOOR PLAN
 Area: 912.80 SQ.M.

INSTITUTE OF ENGINEERING PULCHOWK CAMPUS PULCHOWK, LALITPUR	PROJECT TITLE	SHEET TITLE	SUBMITTED TO:	SUBMITTED BY:		SCALE: FIT TO SCALE
	EARTHQUAKE RESISTANT ANALYSIS AND DESIGN OF MULTIPURPOSE BUILDING	Ground And First Floor Plan	DEPARTMENT OF CIVIL ENGINEERING PULCHOWK CAMPUS	Prakrit Devkota (PUL075BCE101) Ram Krishna Kandel (PUL075BCE116) Safal Katwal (PUL075BCE129)	Priyanshu Pokhrel (PUL075BCE109) Rijab Ali Miya (PUL075BCE119) Sangam Poudel (PUL075BCE142)	SHEET NO. 3
				PROJECT SUPERVISOR:	Asst. Prof. Aakarsha Khawas	SUBMISSION DATE: April 2023

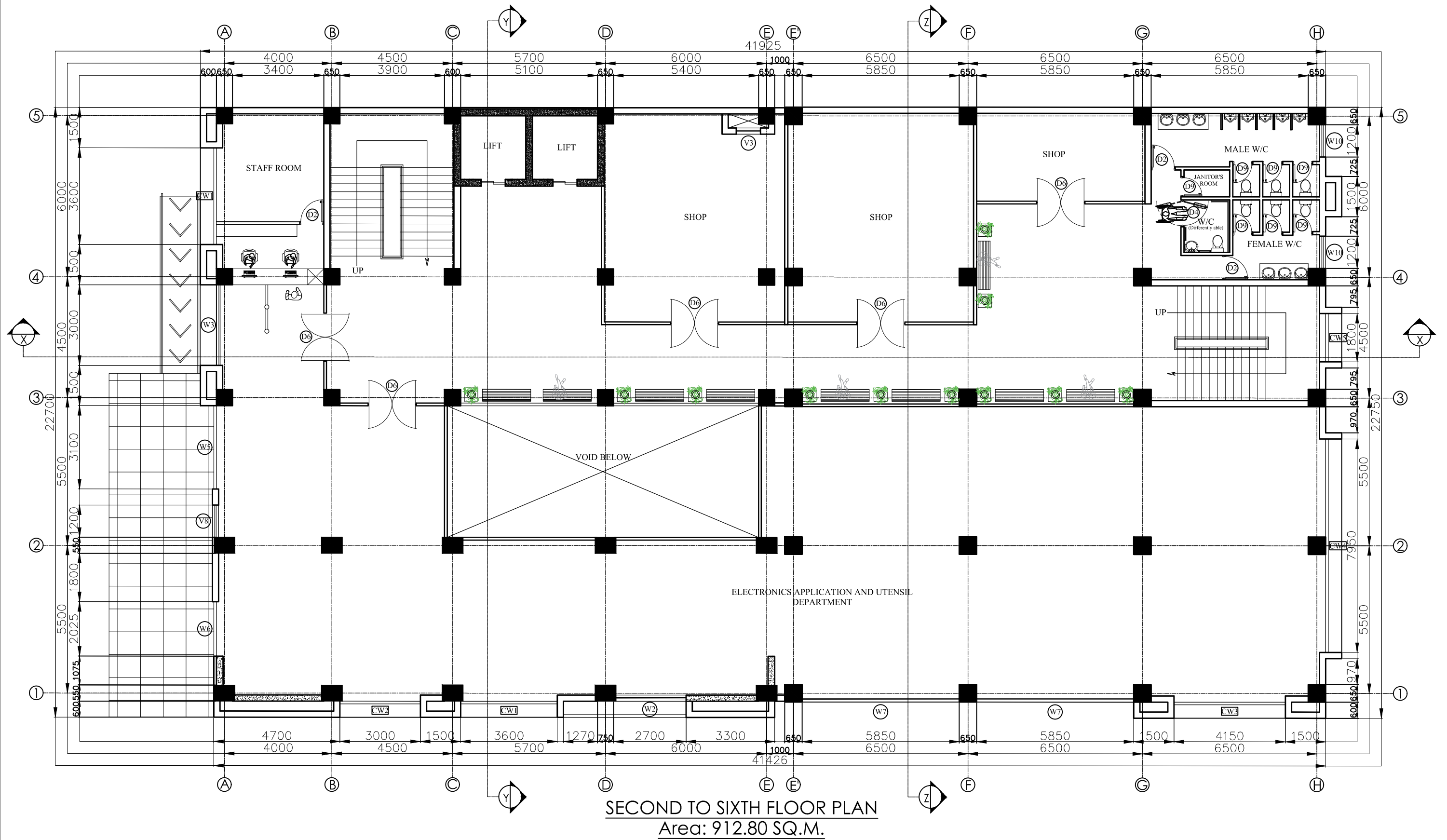

INSTITUTE OF ENGINEERING PULCHOWK CAMPUS PULCHOWK, LALITPUR	PROJECT TITLE	SHEET TITLE	SUBMITTED TO:	SUBMITTED BY:		SCALE: FIT TO SCALE
	EARTHQUAKE RESISTANT ANALYSIS AND DESIGN OF MULTIPURPOSE BUILDING	SECOND TO SIXTH Floor Plan	DEPARTMENT OF CIVIL ENGINEERING PULCHOWK CAMPUS	Prakrit Devkota (PUL075BCE101) Ram Krishna Kandel (PUL075BCE116) Safal Katwal (PUL075BCE129)	Priyanshu Pokhrel (PUL075BCE109) Rijab Ali Miya (PUL075BCE119) Sangam Poudel (PUL075BCE142)	SHEET NO. 4
				PROJECT SUPERVISOR:	Asst. Prof. Aakarsha Khawas	SUBMISSION DATE: April 2023

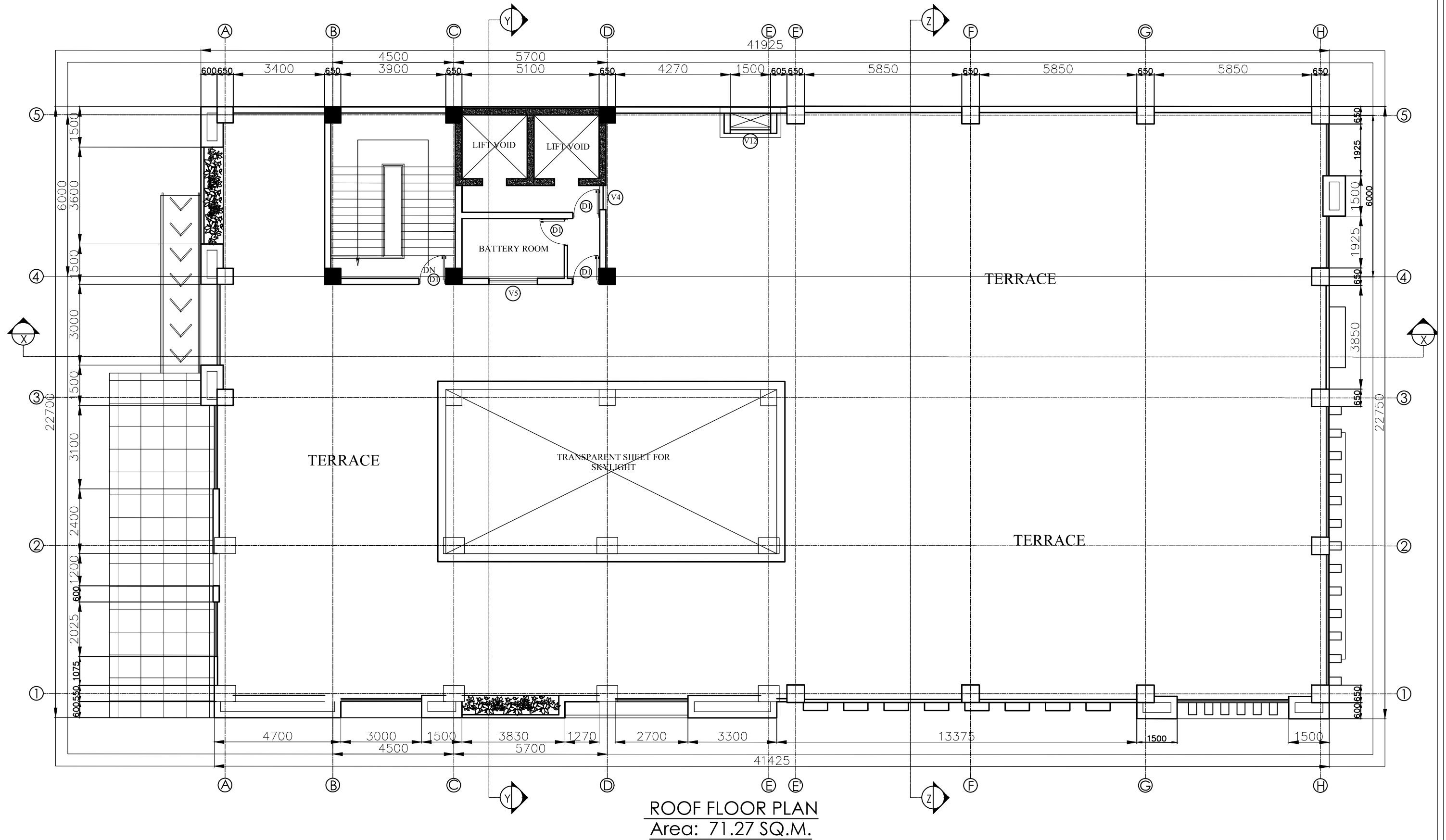

INSTITUTE OF ENGINEERING PULCHOWK CAMPUS PULCHOWK, LALITPUR	PROJECT TITLE	SHEET TITLE	SUBMITTED TO:	SUBMITTED BY:		SCALE: FIT TO SCALE
	EARTHQUAKE RESISTANT ANALYSIS AND DESIGN OF MULTIPURPOSE BUILDING	Roof Floor Plan	DEPARTMENT OF CIVIL ENGINEERING PULCHOWK CAMPUS	Prakrit Devkota (PUL075BCE101)	Priyanshu Pokhrel (PUL075BCE109)	SHEET NO. 5
				Ram Krishna Kandel (PUL075BCE116)	Rijab Ali Miya (PUL075BCE119)	SUBMISSION DATE:
				Safal Katwal (PUL075BCE129)	Sangam Poudel (PUL075BCE142)	April 2023
			PROJECT SUPERVISOR:	Asst. Prof. Aakarsha Khawas		

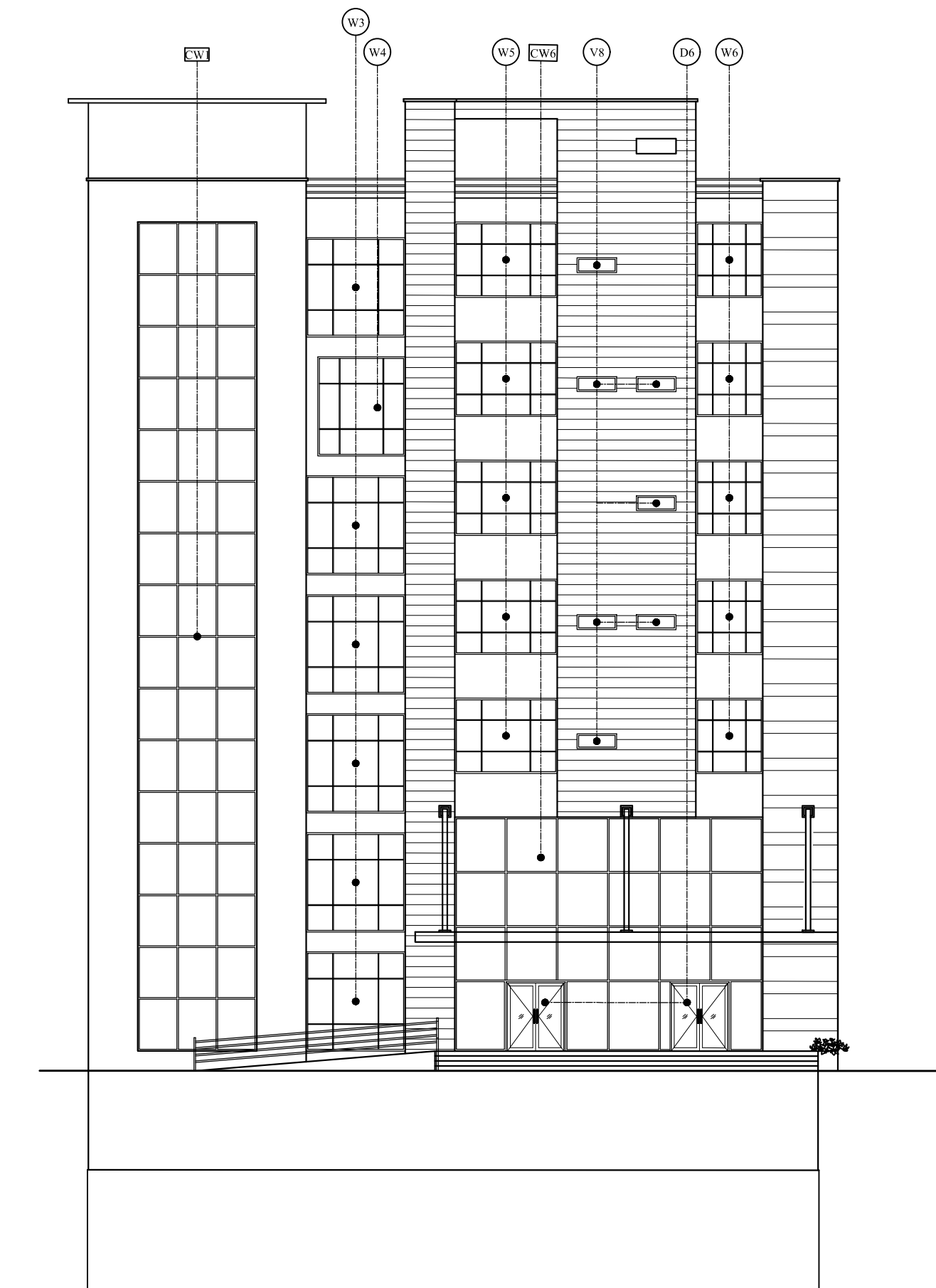

FRONT ELEVATION

INSTITUTE OF ENGINEERING PULCHOWK CAMPUS PULCHOWK, LALITPUR	PROJECT TITLE	SHEET TITLE	SUBMITTED TO:	SUBMITTED BY:		SCALE: FIT TO SCALE
	EARTHQUAKE RESISTANT ANALYSIS AND DESIGN OF MULTIPURPOSE BUILDING	Front Elevation	DEPARTMENT OF CIVIL ENGINEERING PULCHOWK CAMPUS	Prakrit Devkota (PUL075BCE101)	Priyanshu Pokhrel (PUL075BCE109)	SHEET NO. 6
				Ram Krishna Kandel (PUL075BCE116)	Rijab Ali Miya (PUL075BCE119)	
				Safal Katwal (PUL075BCE129)	Sangam Poudel (PUL075BCE142)	SUBMISSION DATE:
				PROJECT SUPERVISOR:	Asst. Prof. Aakarsha Khawas	April 2023

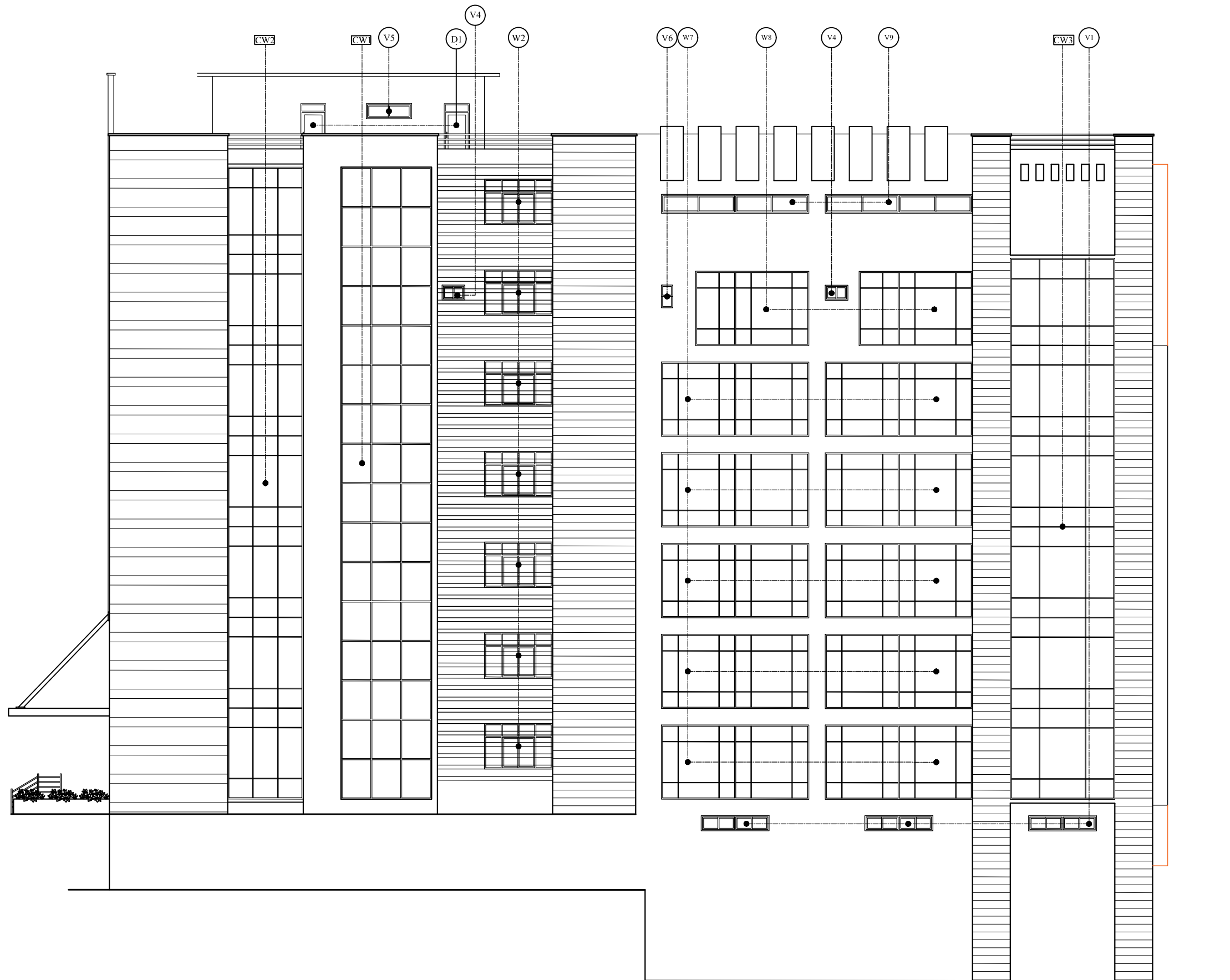

RIGHT ELEVATION

INSTITUTE OF ENGINEERING PULCHOWK CAMPUS PULCHOWK, LALITPUR	PROJECT TITLE	SHEET TITLE	SUBMITTED TO:	SUBMITTED BY:		SCALE: FIT TO SCALE
	EARTHQUAKE RESISTANT ANALYSIS AND DESIGN OF MULTIPURPOSE BUILDING	Right Elevation	DEPARTMENT OF CIVIL ENGINEERING PULCHOWK CAMPUS	Prakrit Devkota (PUL075BCE101)	Priyanshu Pokhrel (PUL075BCE109)	SHEET NO. 7
				Ram Krishna Kandel (PUL075BCE116)	Rijab Ali Miya (PUL075BCE119)	
				Safal Katwal (PUL075BCE129)	Sangam Poudel (PUL075BCE142)	SUBMISSION DATE:
			PROJECT SUPERVISOR:	Asst. Prof. Aakarsha Khawas		April 2023

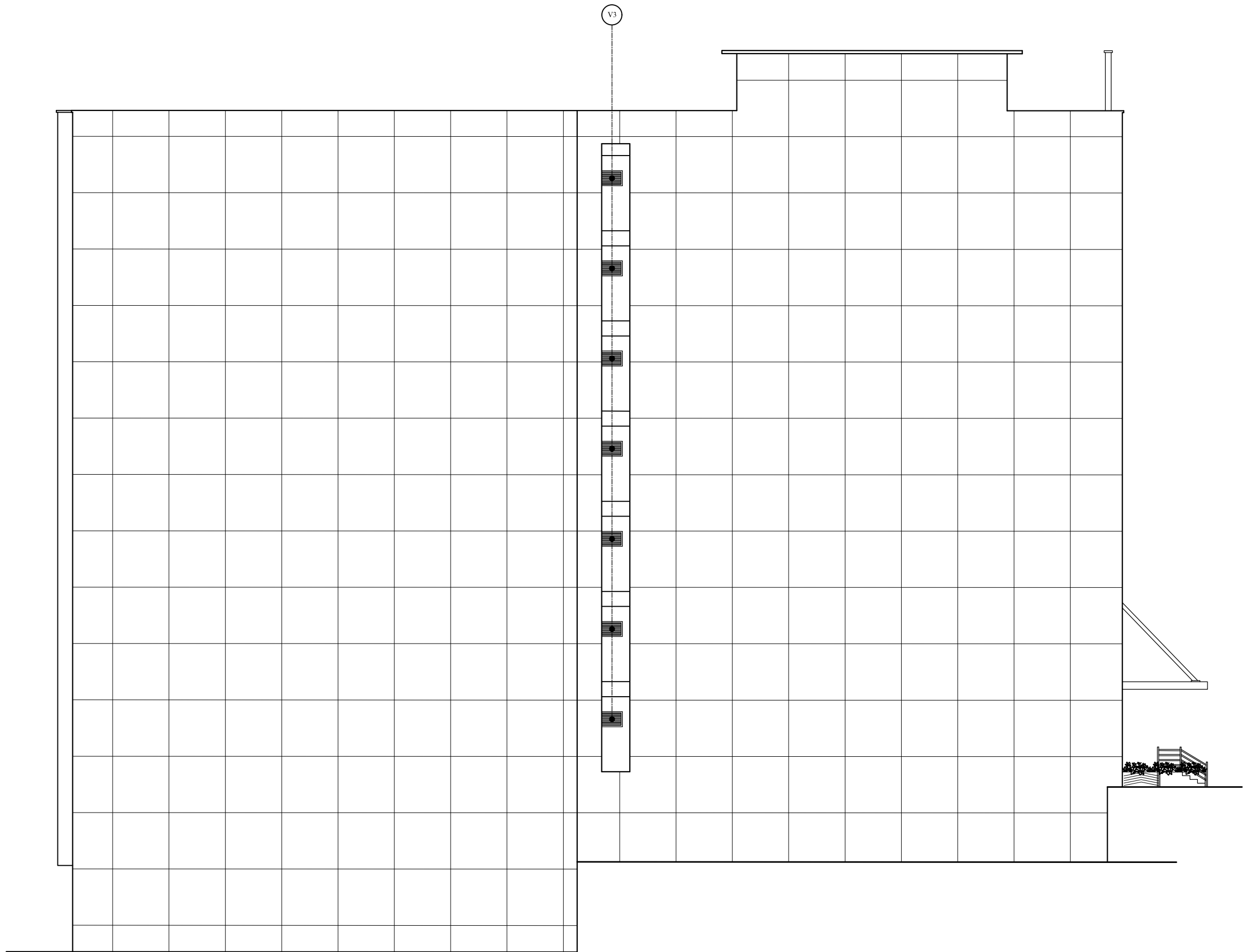

LEFT ELEVATION

INSTITUTE OF ENGINEERING PULCHOWK CAMPUS PULCHOWK, LALITPUR	PROJECT TITLE	SHEET TITLE	SUBMITTED TO:	SUBMITTED BY:		SCALE: FIT TO SCALE
	EARTHQUAKE RESISTANT ANALYSIS AND DESIGN OF MULTIPURPOSE BUILDING	Left Elevation	DEPARTMENT OF CIVIL ENGINEERING PULCHOWK CAMPUS	Prakrit Devkota (PUL075BCE101)	Priyanshu Pokhrel (PUL075BCE109)	SHEET NO. 8
				Ram Krishna Kandel (PUL075BCE116)	Rijab Ali Miya (PUL075BCE119)	
				Safal Katwal (PUL075BCE129)	Sangam Poudel (PUL075BCE142)	SUBMISSION DATE:
			PROJECT SUPERVISOR:	Asst. Prof. Aakarsha Khawas	April 2023	

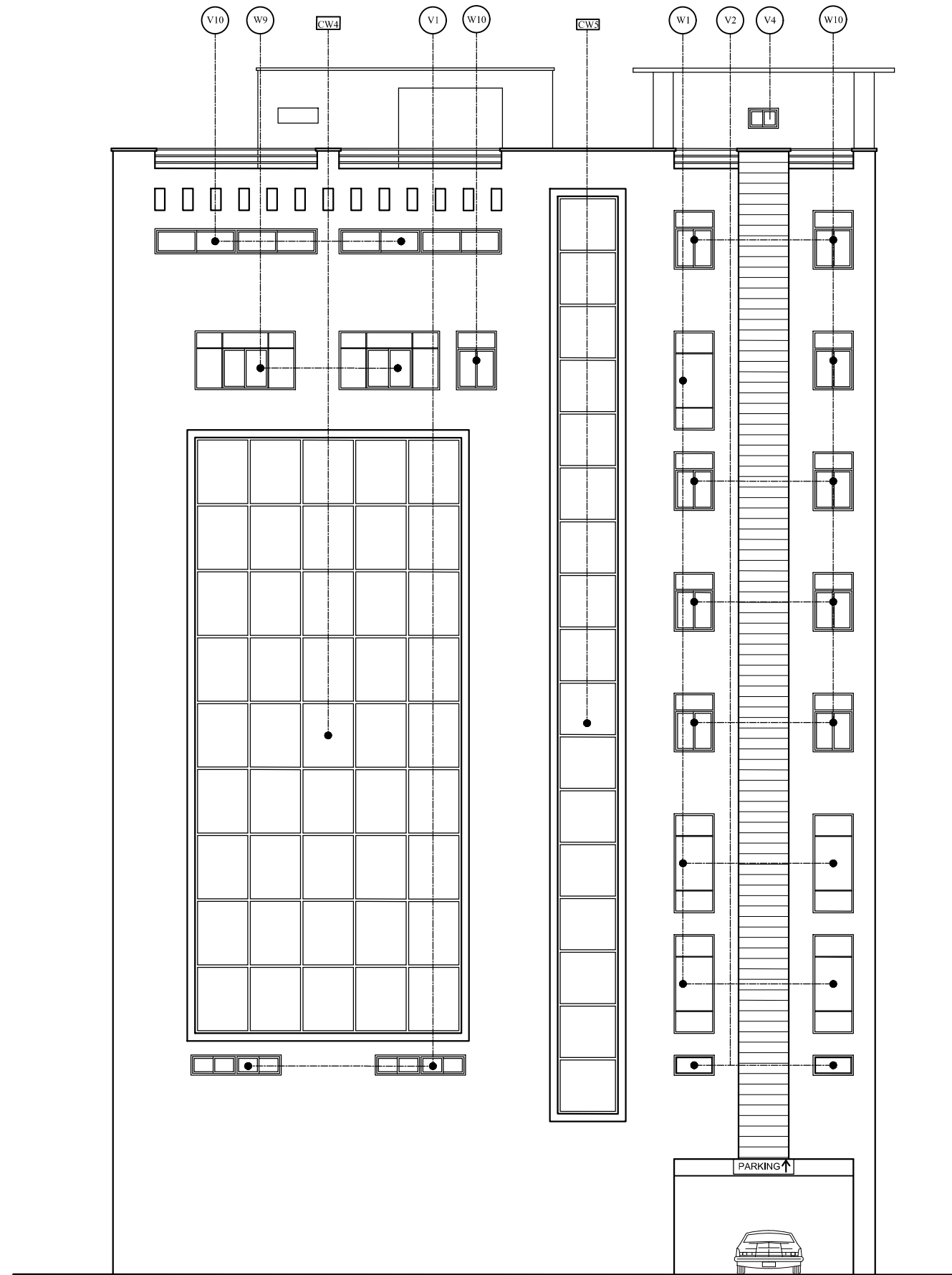

BACK ELEVATION

INSTITUTE OF ENGINEERING PULCHOWK CAMPUS PULCHOWK, LALITPUR	PROJECT TITLE	SHEET TITLE	SUBMITTED TO:	SUBMITTED BY:		SCALE: FIT TO SCALE
	EARTHQUAKE RESISTANT ANALYSIS AND DESIGN OF MULTIPURPOSE BUILDING	Back Elevation	DEPARTMENT OF CIVIL ENGINEERING PULCHOWK CAMPUS	Prakrit Devkota (PUL075BCE101)	Priyanshu Pokhrel (PUL075BCE109)	SHEET NO. 9
				Ram Krishna Kandel (PUL075BCE116)	Rijab Ali Miya (PUL075BCE119)	
				Safal Katwal (PUL075BCE129)	Sangam Poudel (PUL075BCE142)	SUBMISSION DATE: April 2023
				PROJECT SUPERVISOR:	Asst. Prof. Aakarsha Khawas	

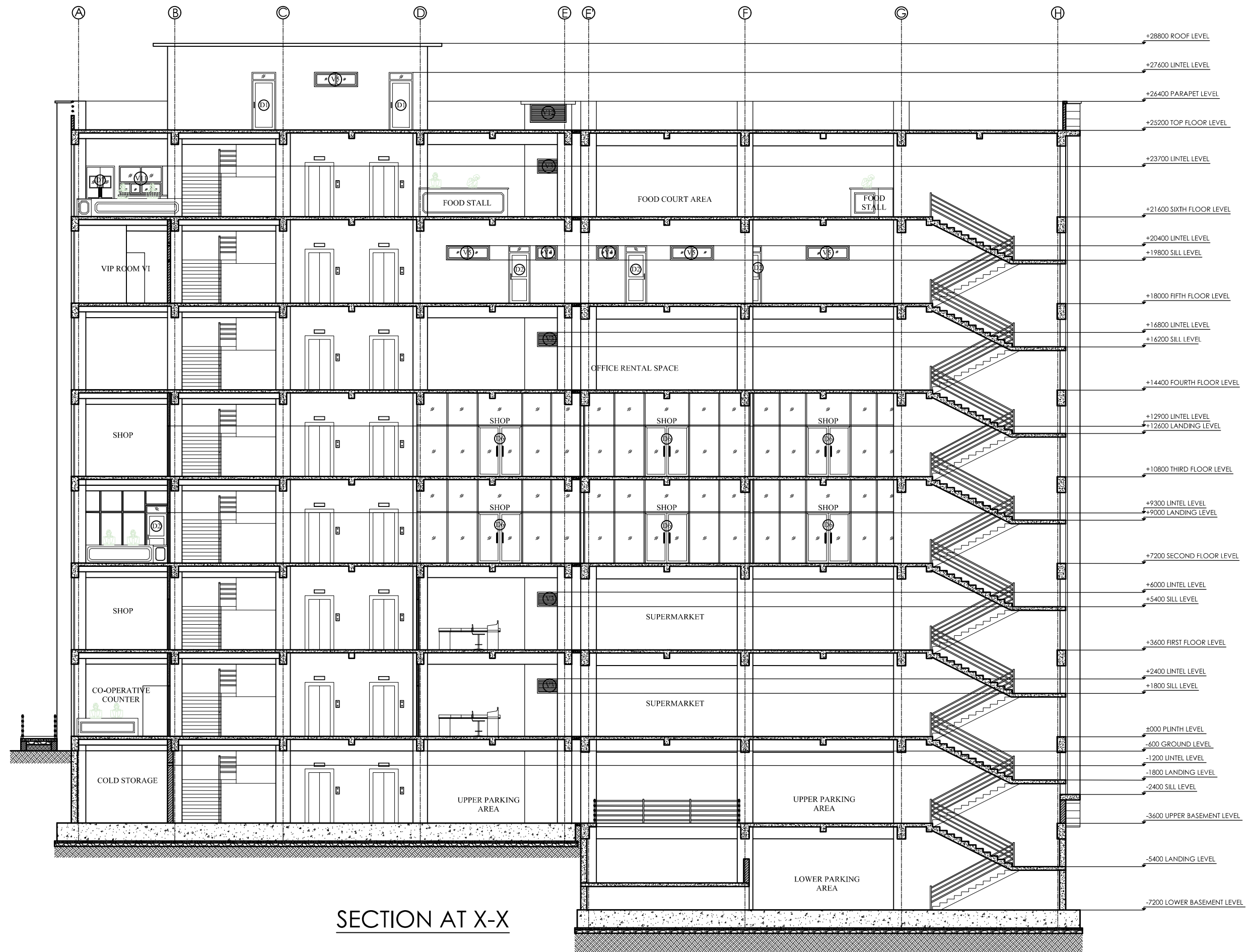

INSTITUTE OF ENGINEERING PULCHOWK CAMPUS PULCHOWK, LALITPUR	PROJECT TITLE	SHEET TITLE	SUBMITTED TO:	SUBMITTED BY:		SCALE: FIT TO SCALE
	EARTHQUAKE RESISTANT ANALYSIS AND DESIGN OF MULTIPURPOSE BUILDING	Section at X-X	DEPARTMENT OF CIVIL ENGINEERING PULCHOWK CAMPUS	Prakrit Devkota (PUL075BCE101)	Priyanshu Pokhrel (PUL075BCE109)	SHEET NO. 10
				Ram Krishna Kandel (PUL075BCE116)	Rijab Ali Miya (PUL075BCE119)	SUBMISSION DATE:
				Safal Katwal (PUL075BCE129)	Sangam Poudel (PUL075BCE142)	April 2023
			PROJECT SUPERVISOR:	Asst. Prof. Aakarsha Khawas		

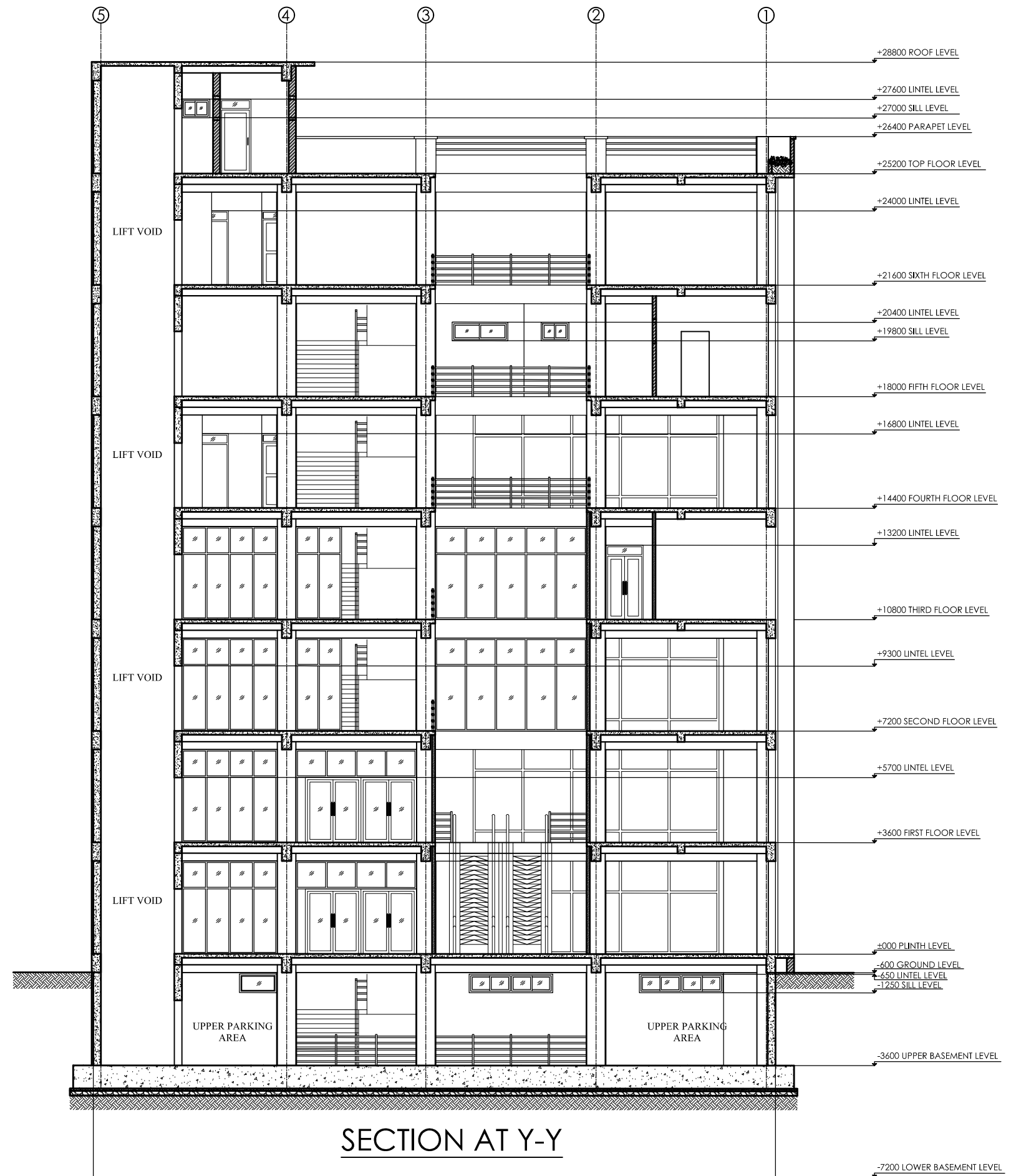

INSTITUTE OF ENGINEERING PULCHOWK CAMPUS PULCHOWK, LALITPUR	PROJECT TITLE	SHEET TITLE	SUBMITTED TO:	SUBMITTED BY:		SCALE: FIT TO SCALE
	EARTHQUAKE RESISTANT ANALYSIS AND DESIGN OF MULTIPURPOSE BUILDING	Section at Y-Y	DEPARTMENT OF CIVIL ENGINEERING PULCHOWK CAMPUS	Prakrit Devkota (PUL075BCE101)	Priyanshu Pokhrel (PUL075BCE109)	SHEET NO. 11
				Ram Krishna Kandel (PUL075BCE116)	Rijab Ali Miya (PUL075BCE119)	
				Safal Katwal (PUL075BCE129)	Sangam Poudel (PUL075BCE142)	SUBMISSION DATE: April 2023
			PROJECT SUPERVISOR:	Asst. Prof. Aakarsha Khawas		

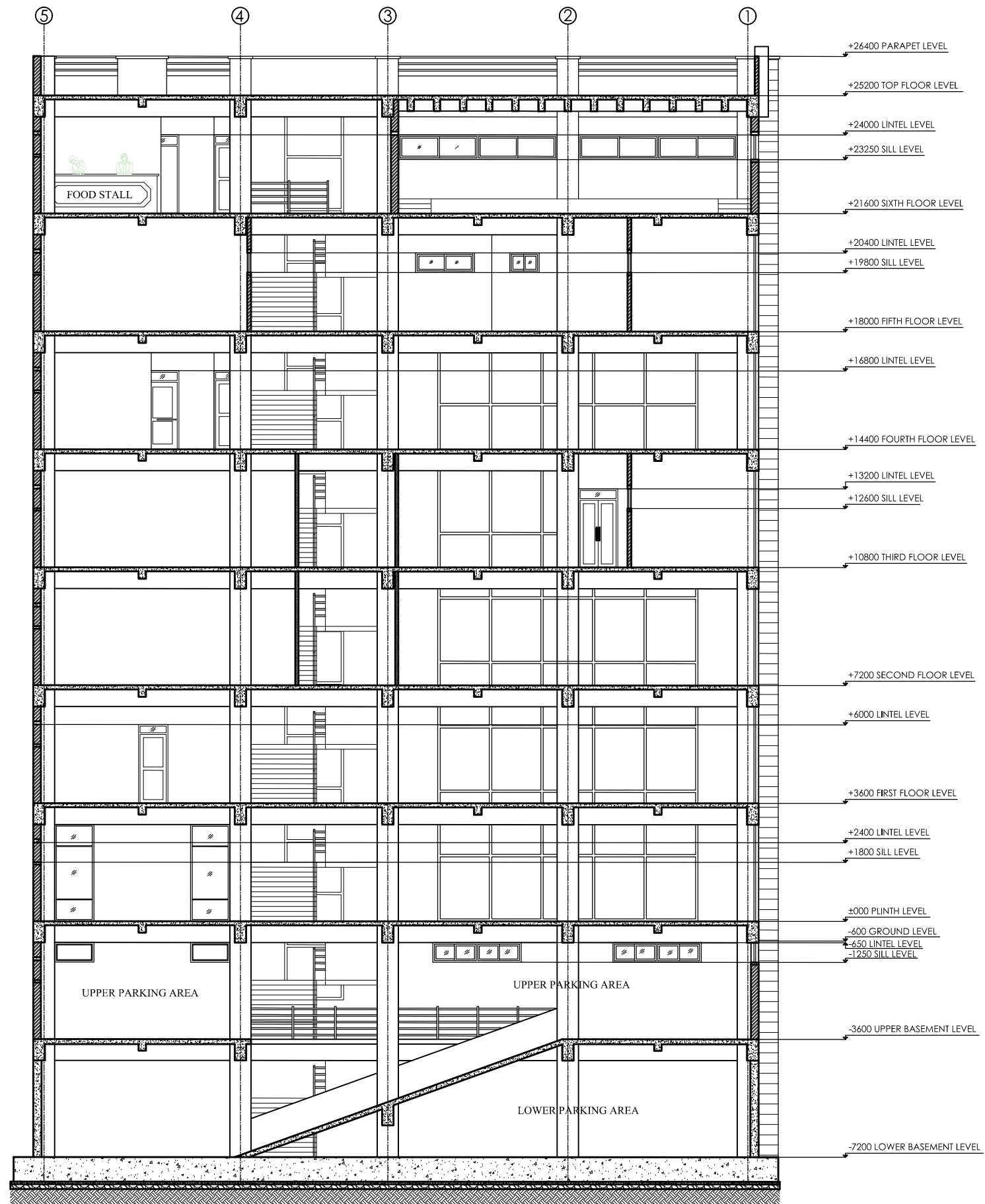

SECTION AT Z-Z

INSTITUTE OF ENGINEERING PULCHOWK CAMPUS PULCHOWK, LALITPUR	PROJECT TITLE	SHEET TITLE	SUBMITTED TO:	SUBMITTED BY:		SCALE: FIT TO SCALE
	EARTHQUAKE RESISTANT ANALYSIS AND DESIGN OF MULTIPURPOSE BUILDING	Section at Z-Z	DEPARTMENT OF CIVIL ENGINEERING PULCHOWK CAMPUS	Prakrit Devkota (PUL075BCE101)	Priyanshu Pokhrel (PUL075BCE109)	SHEET NO. 12
				Ram Krishna Kandel (PUL075BCE116)	Rijab Ali Miya (PUL075BCE119)	
				Safal Katwal (PUL075BCE129)	Sangam Poudel (PUL075BCE142)	SUBMISSION DATE: April 2023
PROJECT SUPERVISOR:				Asst. Prof. Aakarsha Khawas		

ANNEX C

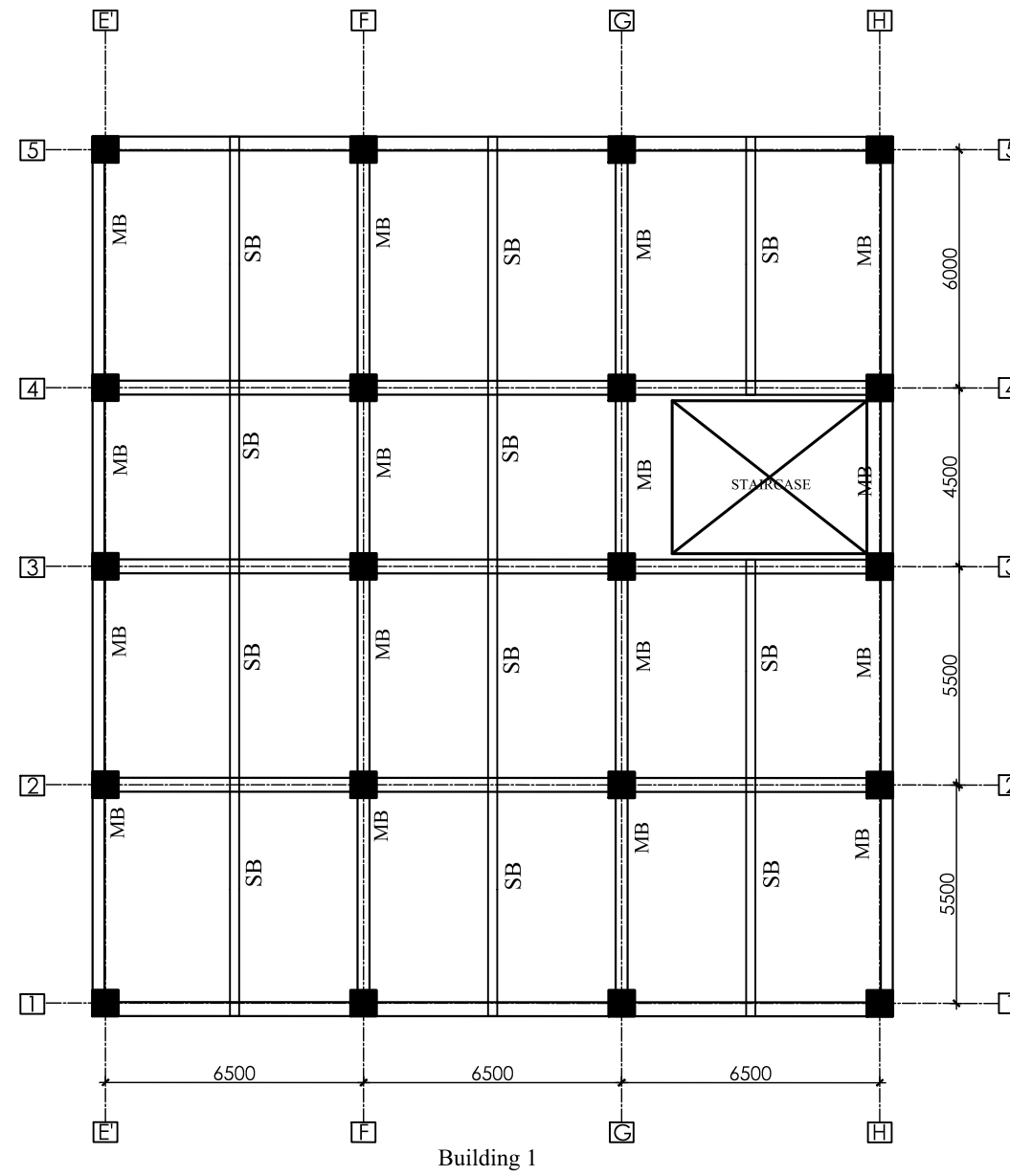
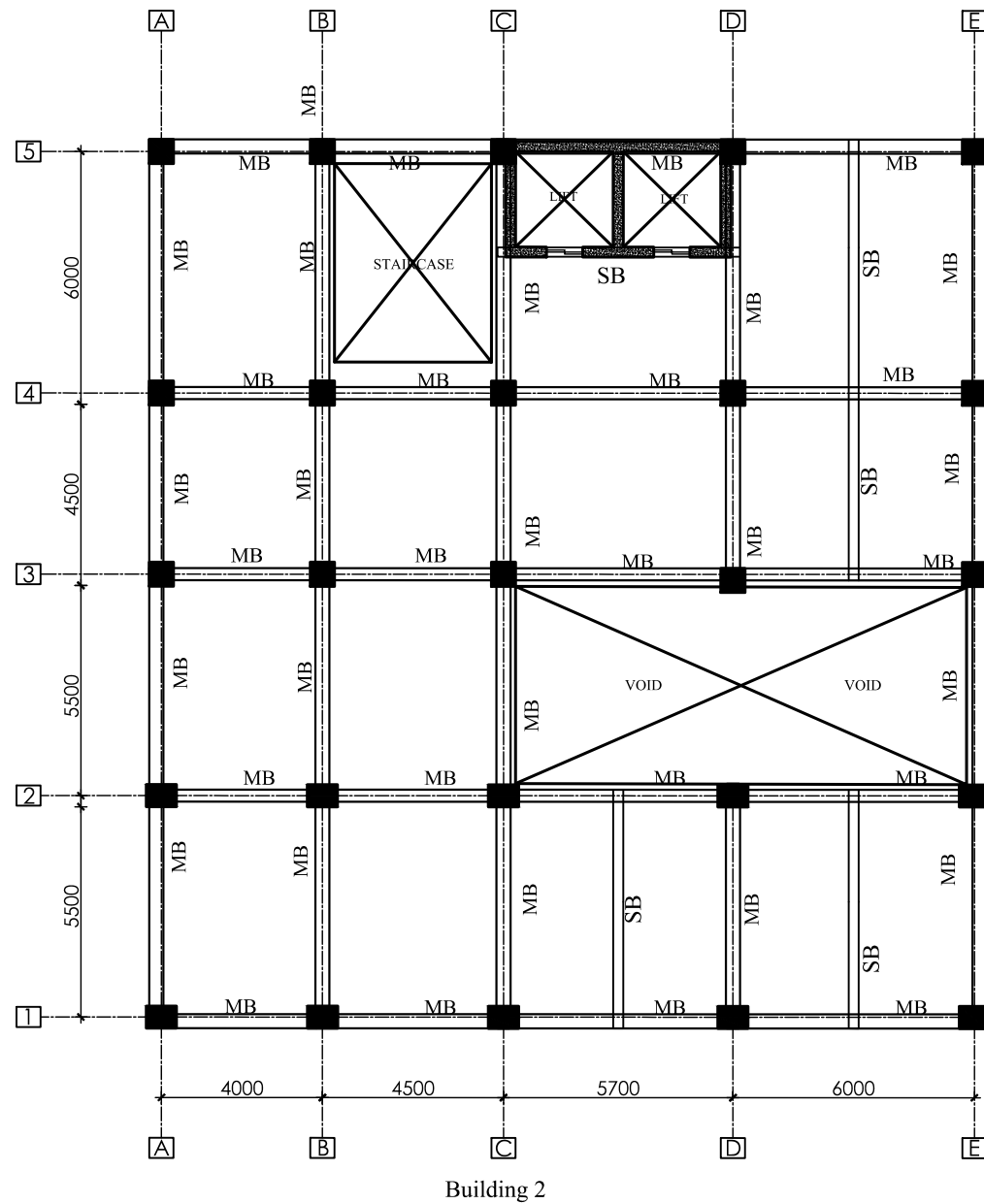

MB : Main Beam 650*350
 SB : Secondary Beam 350*250

INSTITUTE OF ENGINEERING PULCHOWK CAMPUS PULCHOWK, LALITPUR	PROJECT TITLE	SHEET TITLE	SUBMITTED TO:	SUBMITTED BY:		SCALE: FIT TO SCALE
	EARTHQUAKE RESISTANT ANALYSIS AND DESIGN OF MULTIPURPOSE BUILDING	BEAM LAYOUT PLAN	DEPARTMENT OF CIVIL ENGINEERING PULCHOWK CAMPUS	Prakrit Devkota (PUL075BCE101)	Priyanshu Pokhrel (PUL075BCE109)	SHEET NO. 13
				Ram Krishna Kandel (PUL075BCE116)	Rijab Ali Miya (PUL075BCE119)	
				Safal Katwal (PUL075BCE129)	Sangam Poudel (PUL075BCE142)	SUBMISSION DATE: April 2023
			PROJECT SUPERVISOR:	Asst. Prof. Aakarsha Khawas		

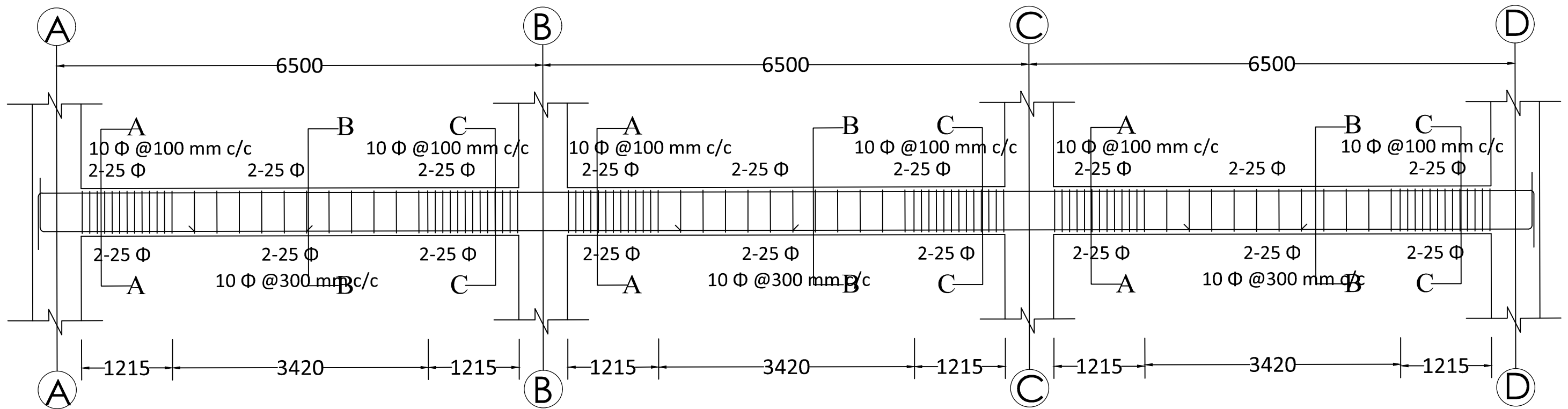

REINFORCEMENT DETAILING GRID 4 UPPER BASEMENT

INSTITUTE OF ENGINEERING PULCHOWK CAMPUS PULCHOWK, LALITPUR	PROJECT TITLE	SHEET TITLE	SUBMITTED TO:	SUBMITTED BY:		SCALE: FIT TO SCALE
	EARTHQUAKE RESISTANT ANALYSIS AND DESIGN OF MULTIPURPOSE BUILDING	UPPER BASEMENT BEAM DETAILING OF BUILDING 1	DEPARTMENT OF CIVIL ENGINEERING PULCHOWK CAMPUS	Prakrit Devkota (PUL075BCE101)	Priyanshu Pokhrel (PUL075BCE109)	SHEET NO. 14
				Ram Krishna Kandel (PUL075BCE116)	Rijab Ali Miya (PUL075BCE119)	
				Safal Katwal (PUL075BCE129)	Sangam Poudel (PUL075BCE142)	SUBMISSION DATE:
				PROJECT SUPERVISOR:	Asst. Prof. Aakarsha Khawas	April 2023

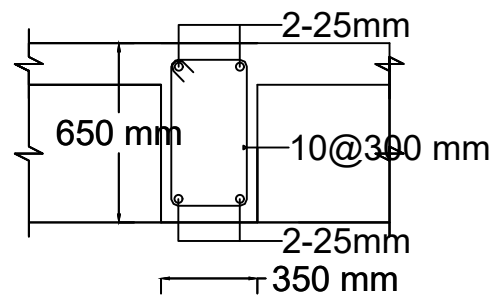

Section at A-A

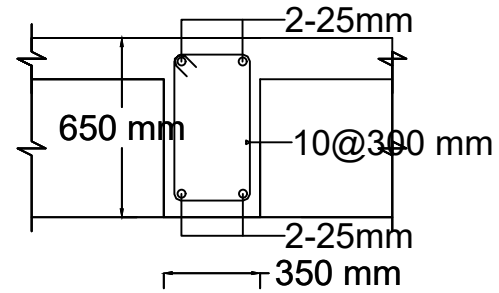

Section at B-B

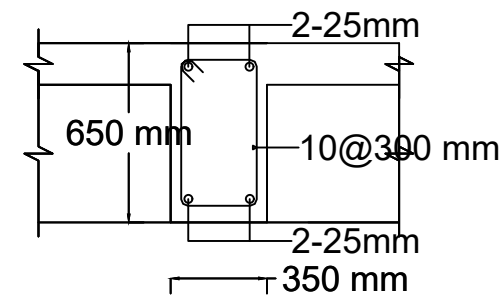

Section at C-C

UPPER BASEMENT BEAM AB - 4th GRID

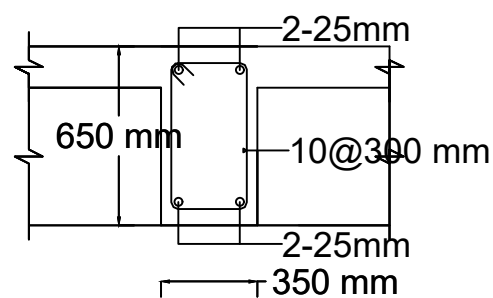

Section at A-A

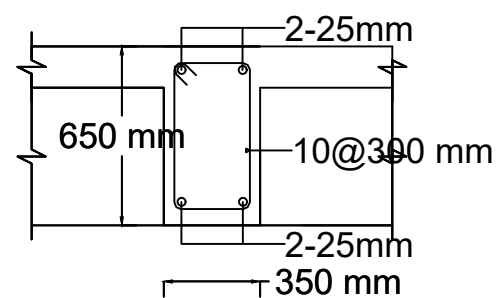

Section at B-B

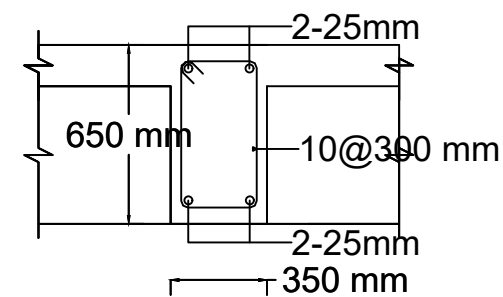

Section at C-C

UPPER BASEMENT BEAM BC - 4th GRID

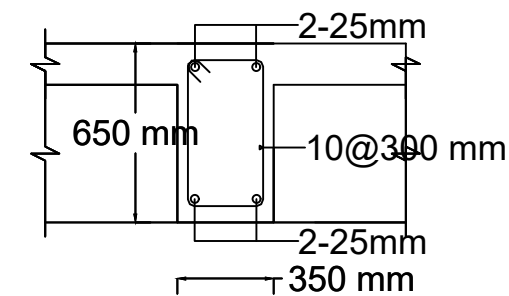

Section at A-A

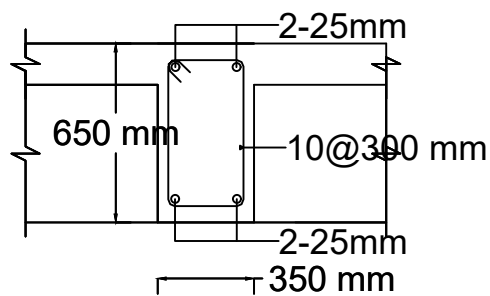

Section at B-B

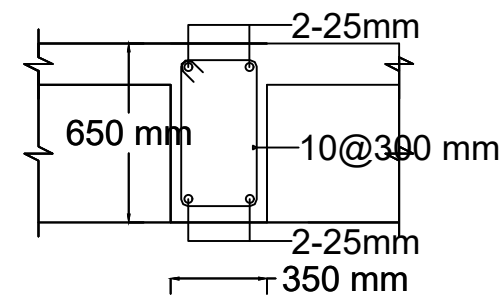

Section at C-C

UPPER BASEMENT BEAM CD - 4th GRID

INSTITUTE OF ENGINEERING PULCHOWK CAMPUS PULCHOWK, LALITPUR	PROJECT TITLE	SHEET TITLE	SUBMITTED TO:	SUBMITTED BY:		SCALE: FIT TO SCALE
	EARTHQUAKE RESISTANT ANALYSIS AND DESIGN OF MULTIPURPOSE BUILDING	UPPER BASEMENT BEAM SECTIONS OF BUILDING 1	DEPARTMENT OF CIVIL ENGINEERING PULCHOWK CAMPUS	Prakrit Devkota (PUL075BCE101)	Priyanshu Pokhrel (PUL075BCE109)	SHEET NO. 15
				Ram Krishna Kandel (PUL075BCE116)	Rijab Ali Miya (PUL075BCE119)	
				Safal Katwal (PUL075BCE129)	Sangam Poudel (PUL075BCE142)	SUBMISSION DATE: April 2023
			PROJECT SUPERVISOR:	Asst. Prof. Aakarsha Khawas		

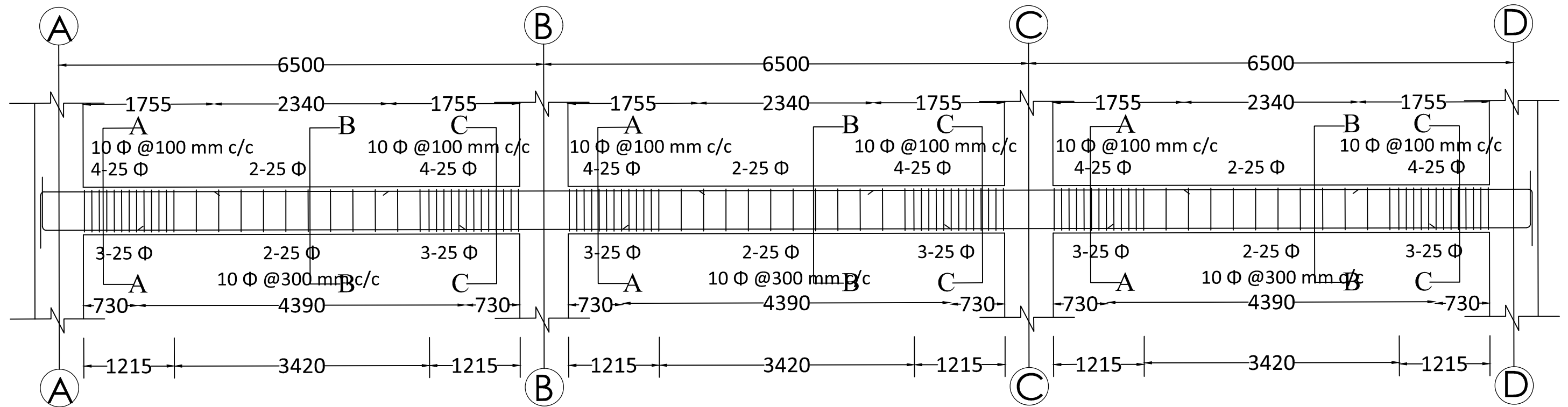

REINFORCEMENT DETAILING GRID 4 GROUND FLOOR

INSTITUTE OF ENGINEERING PULCHOWK CAMPUS PULCHOWK, LALITPUR	PROJECT TITLE	SHEET TITLE	SUBMITTED TO:	SUBMITTED BY:		SCALE: FIT TO SCALE
	EARTHQUAKE RESISTANT ANALYSIS AND DESIGN OF MULTIPURPOSE BUILDING	GROUND FLOOR BEAM DETAILING OF BUILDING 1	DEPARTMENT OF CIVIL ENGINEERING PULCHOWK CAMPUS	Prakrit Devkota (PUL075BCE101)	Priyanshu Pokhrel (PUL075BCE109)	SHEET NO. 16
				Ram Krishna Kandel (PUL075BCE116)	Rijab Ali Miya (PUL075BCE119)	
				Safal Katwal (PUL075BCE129)	Sangam Poudel (PUL075BCE142)	SUBMISSION DATE: April 2023
PROJECT SUPERVISOR:				Asst. Prof. Aakarsha Khawas		

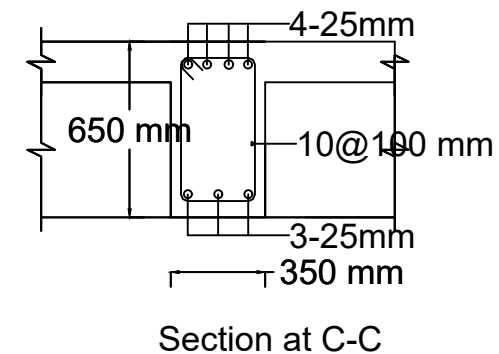
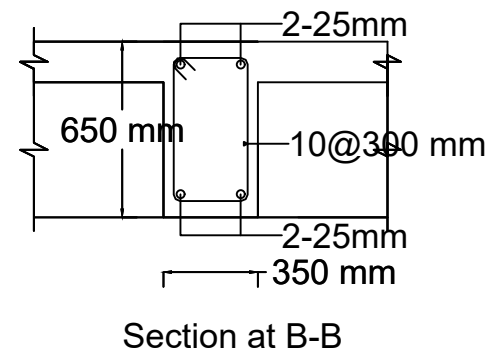
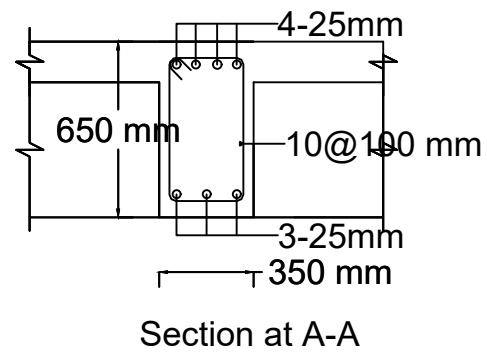

GROUND FLOOR BEAM AB - 4th GRID

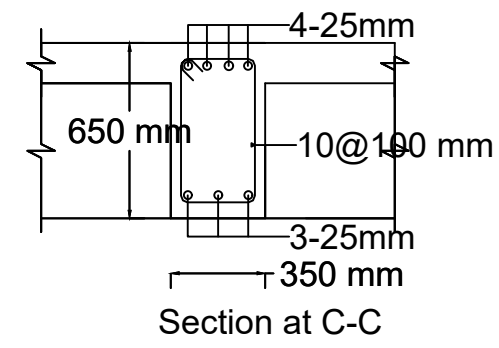
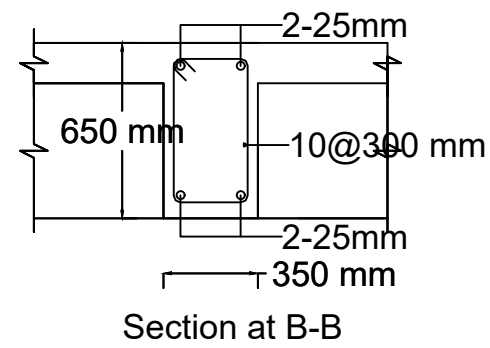
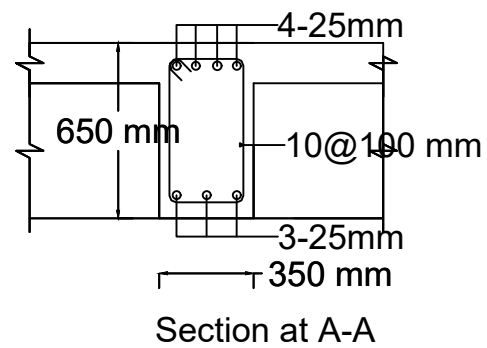

GROUND FLOOR BEAM BC - 4th GRID

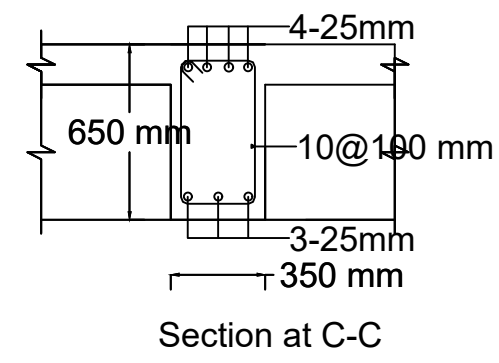
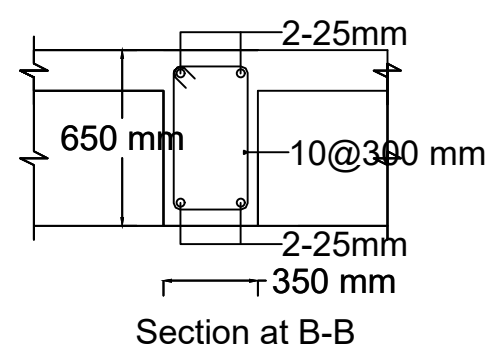
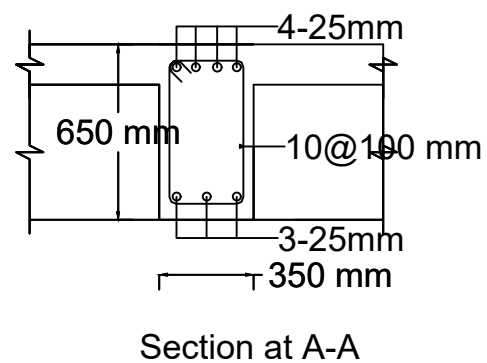

GROUND FLOOR BEAM CD - 4th GRID

INSTITUTE OF ENGINEERING PULCHOWK CAMPUS PULCHOWK, LALITPUR	PROJECT TITLE	SHEET TITLE	SUBMITTED TO:	SUBMITTED BY:		SCALE: FIT TO SCALE
	EARTHQUAKE RESISTANT ANALYSIS AND DESIGN OF MULTIPURPOSE BUILDING	GROUND FLOOR BEAM SECTIONS OF BUILDING 1	DEPARTMENT OF CIVIL ENGINEERING PULCHOWK CAMPUS	Prakrit Devkota (PUL075BCE101)	Priyanshu Pokhrel (PUL075BCE109)	SHEET NO. 17
				Ram Krishna Kandel (PUL075BCE116)	Rijab Ali Miya (PUL075BCE119)	
				Safal Katwal (PUL075BCE129)	Sangam Poudel (PUL075BCE142)	SUBMISSION DATE: April 2023
			PROJECT SUPERVISOR:	Asst. Prof. Aakarsha Khawas		

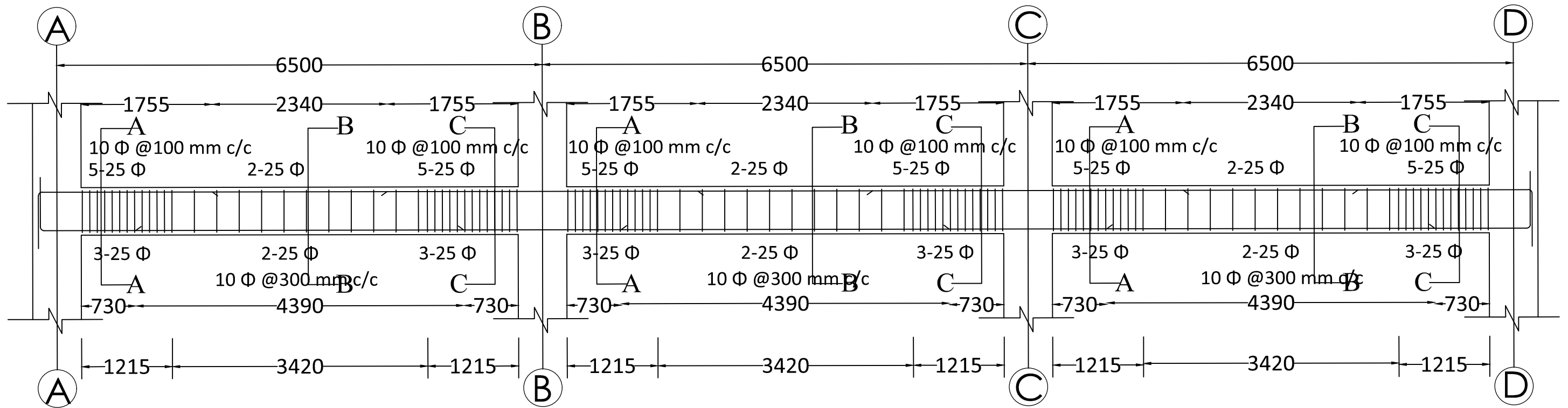

REINFORCEMENT DETAILING GRID 4 1ST FLOOR

INSTITUTE OF ENGINEERING PULCHOWK CAMPUS PULCHOWK, LALITPUR	PROJECT TITLE	SHEET TITLE	SUBMITTED TO:	SUBMITTED BY:		SCALE: FIT TO SCALE
	EARTHQUAKE RESISTANT ANALYSIS AND DESIGN OF MULTIPURPOSE BUILDING	FIRST FLOOR BEAM DETAILING OF BUILDING 1	DEPARTMENT OF CIVIL ENGINEERING PULCHOWK CAMPUS	Prakrit Devkota (PUL075BCE101)	Priyanshu Pokhrel (PUL075BCE109)	SHEET NO. 18
				Ram Krishna Kandel (PUL075BCE116)	Rijab Ali Miya (PUL075BCE119)	
				Safal Katwal (PUL075BCE129)	Sangam Poudel (PUL075BCE142)	SUBMISSION DATE: April 2023
PROJECT SUPERVISOR:				Asst. Prof. Aakarsha Khawas		

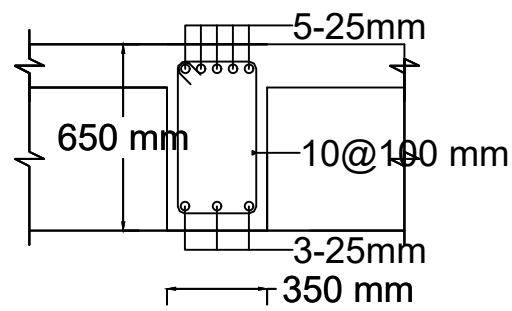

Section at A-A

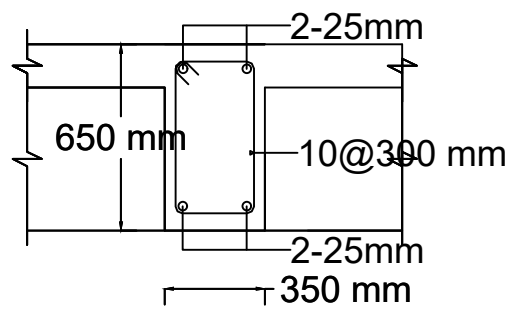

Section at B-B

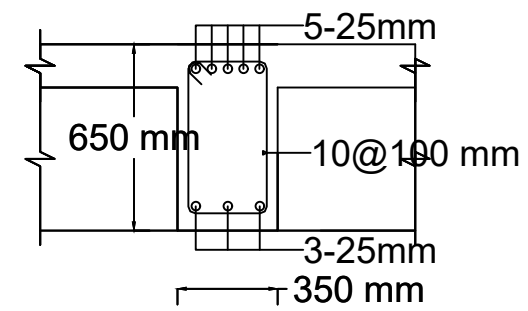

Section at C-C

FIRST FLOOR BEAM AB - 4th GRID

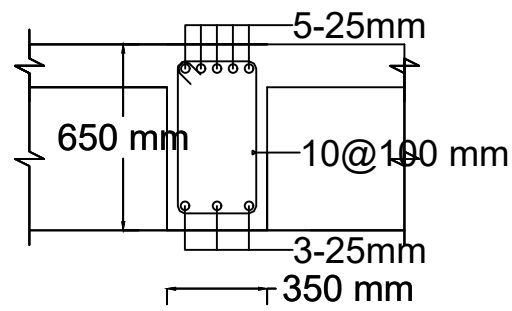

Section at A-A

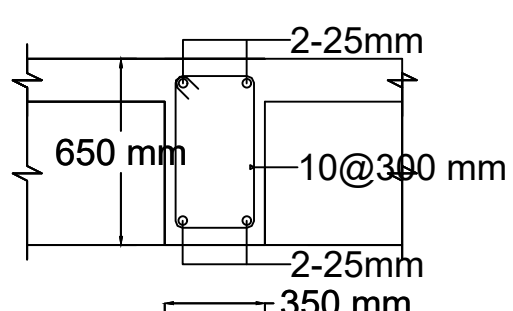

Section at B-B

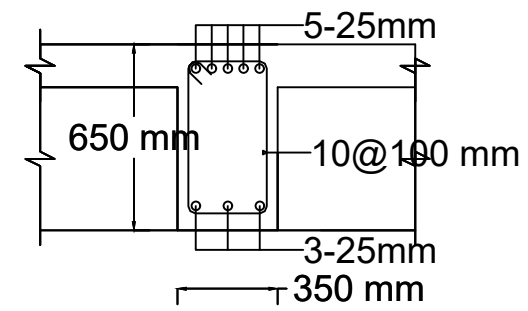

Section at C-C

FIRST FLOOR BEAM BC - 4th GRID

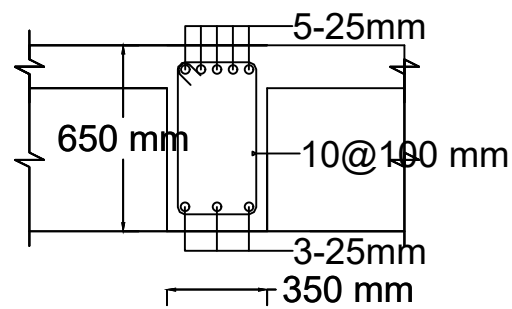

Section at A-A

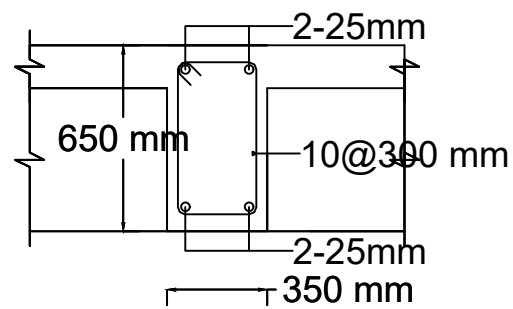

Section at B-B

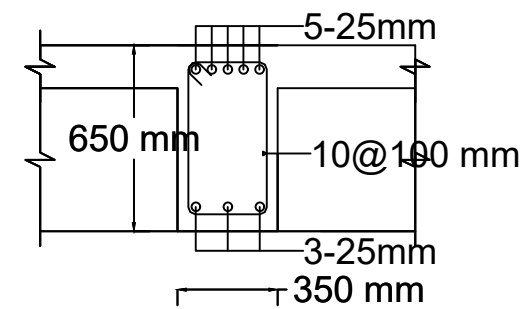

Section at C-C

FIRST FLOOR BEAM CD - 4th GRID

INSTITUTE OF ENGINEERING PULCHOWK CAMPUS PULCHOWK, LALITPUR	PROJECT TITLE	SHEET TITLE	SUBMITTED TO:	SUBMITTED BY:		SCALE: FIT TO SCALE
	EARTHQUAKE RESISTANT ANALYSIS AND DESIGN OF MULTIPURPOSE BUILDING	FIRST FLOOR BEAM SECTIONS OF BUILDING 1	DEPARTMENT OF CIVIL ENGINEERING PULCHOWK CAMPUS	Prakrit Devkota (PUL075BCE101)	Priyanshu Pokhrel (PUL075BCE109)	SHEET NO. 19
				Ram Krishna Kandel (PUL075BCE116)	Rijab Ali Miya (PUL075BCE119)	
				Safal Katwal (PUL075BCE129)	Sangam Poudel (PUL075BCE142)	SUBMISSION DATE: April 2023
			PROJECT SUPERVISOR:	Asst. Prof. Aakarsha Khawas		

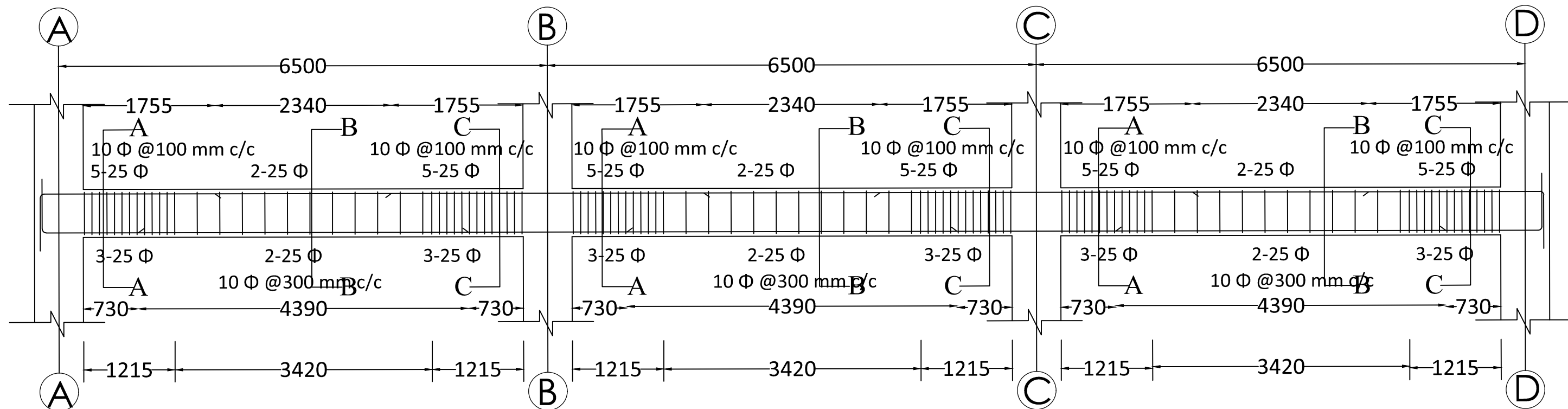

REINFORCEMENT DETAILING GRID 4 2ND FLOOR

INSTITUTE OF ENGINEERING PULCHOWK CAMPUS PULCHOWK, LALITPUR	PROJECT TITLE	SHEET TITLE	SUBMITTED TO:	SUBMITTED BY:		SCALE: FIT TO SCALE
	EARTHQUAKE RESISTANT ANALYSIS AND DESIGN OF MULTIPURPOSE BUILDING	SECOND FLOOR BEAM DETAILING OF BUILDING 1	DEPARTMENT OF CIVIL ENGINEERING PULCHOWK CAMPUS	Prakrit Devkota (PUL075BCE101)	Priyanshu Pokhrel (PUL075BCE109)	SHEET NO. 20
				Ram Krishna Kandel (PUL075BCE116)	Rijab Ali Miya (PUL075BCE119)	
				Safal Katwal (PUL075BCE129)	Sangam Poudel (PUL075BCE142)	
PROJECT SUPERVISOR:				Asst. Prof. Aakarsha Khawas	SUBMISSION DATE: April 2023	

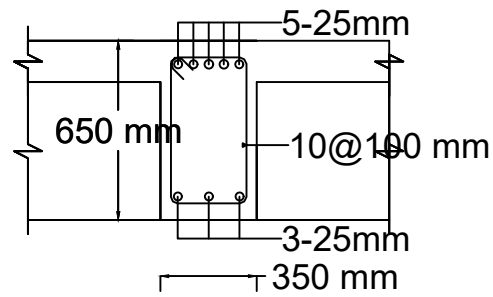

Section at A-A

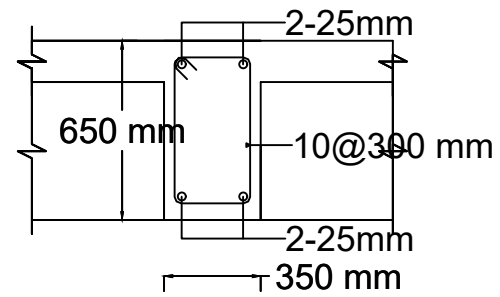

Section at B-B

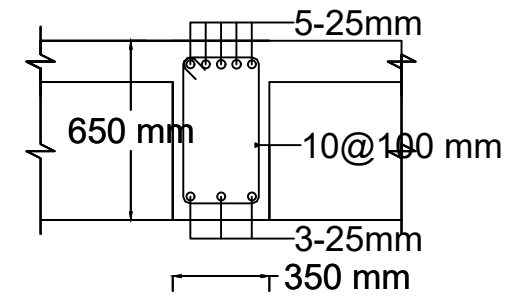

Section at C-C

SECOND FLOOR BEAM AB - 4th GRID

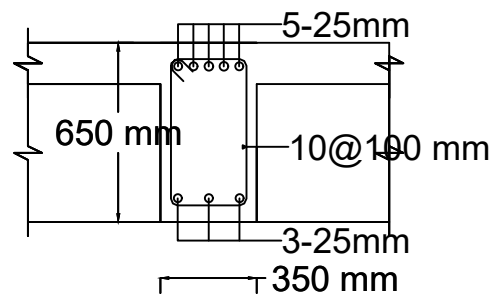

Section at A-A

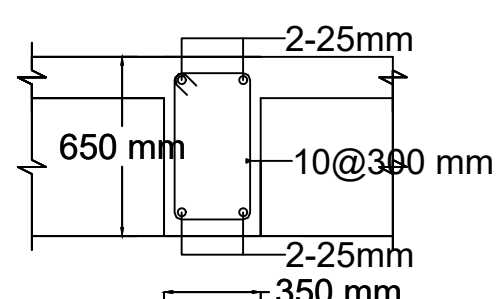

Section at B-B

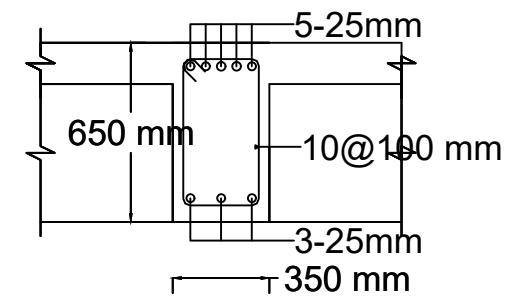

Section at C-C

SECOND FLOOR BEAM BC - 4th GRID

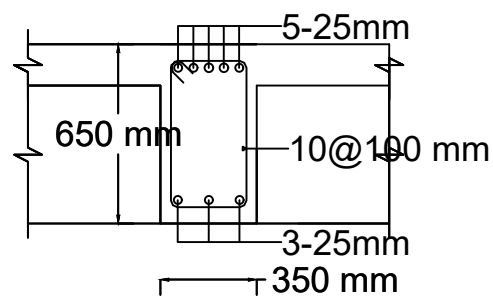

Section at A-A

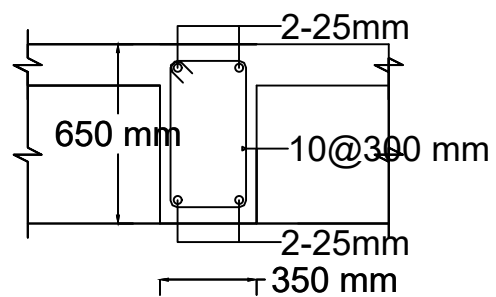

Section at B-B

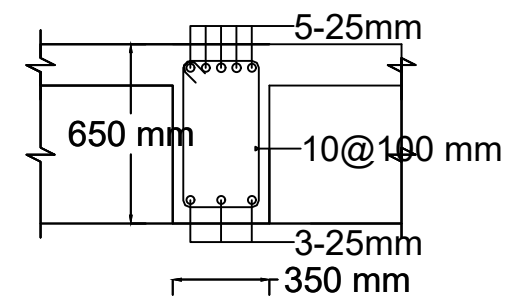

Section at C-C

SECOND FLOOR BEAM CD - 4th GRID

INSTITUTE OF ENGINEERING PULCHOWK CAMPUS PULCHOWK, LALITPUR	PROJECT TITLE	SHEET TITLE	SUBMITTED TO:	SUBMITTED BY:		SCALE: FIT TO SCALE
	EARTHQUAKE RESISTANT ANALYSIS AND DESIGN OF MULTIPURPOSE BUILDING	SECOND FLOOR BEAM SECTIONS OF BUILDING 1	DEPARTMENT OF CIVIL ENGINEERING PULCHOWK CAMPUS	Prakrit Devkota (PUL075BCE101)	Priyanshu Pokhrel (PUL075BCE109)	SHEET NO. 21
				Ram Krishna Kandel (PUL075BCE116)	Rijab Ali Miya (PUL075BCE119)	
				Safal Katwal (PUL075BCE129)	Sangam Poudel (PUL075BCE142)	SUBMISSION DATE: April 2023
			PROJECT SUPERVISOR:	Asst. Prof. Aakarsha Khawas		

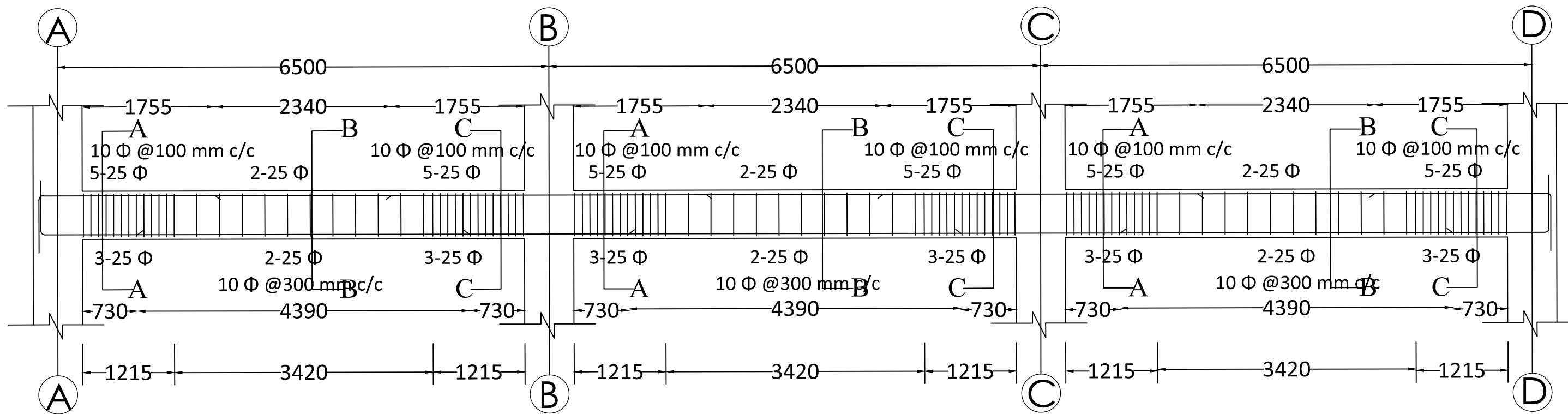

REINFORCEMENT DETAILING GRID 4 3RD FLOOR

INSTITUTE OF ENGINEERING PULCHOWK CAMPUS PULCHOWK, LALITPUR	PROJECT TITLE	SHEET TITLE	SUBMITTED TO:	SUBMITTED BY:		SCALE: FIT TO SCALE
	EARTHQUAKE RESISTANT ANALYSIS AND DESIGN OF MULTIPURPOSE BUILDING	THIRD FLOOR BEAM DETAILING OF BUILDING 1	DEPARTMENT OF CIVIL ENGINEERING PULCHOWK CAMPUS	Prakrit Devkota (PUL075BCE101)	Priyanshu Pokhrel (PUL075BCE109)	SHEET NO. 22
				Ram Krishna Kandel (PUL075BCE116)	Rijab Ali Miya (PUL075BCE119)	
				Safal Katwal (PUL075BCE129)	Sangam Poudel (PUL075BCE142)	SUBMISSION DATE:
				PROJECT SUPERVISOR:	Asst. Prof. Aakarsha Khawas	April 2023

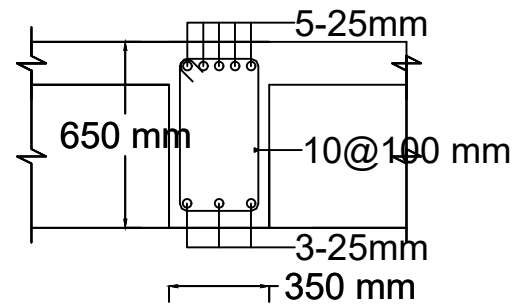

Section at A-A

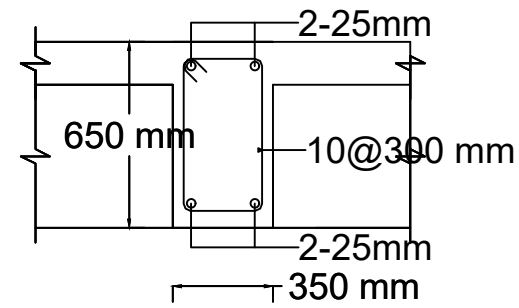

Section at B-B

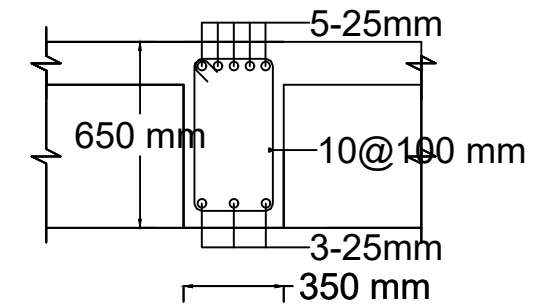

Section at C-C

THIRD FLOOR BEAM AB - 4th GRID

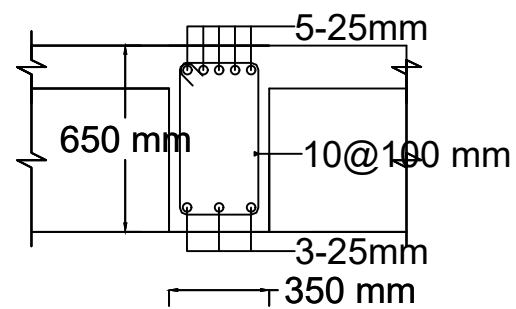

Section at A-A

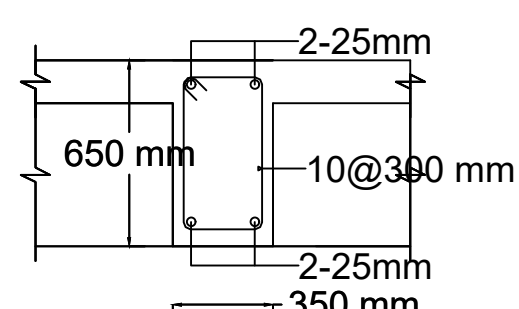

Section at B-B

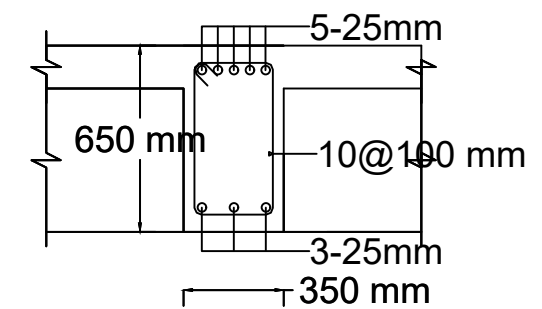

Section at C-C

THIRD FLOOR BEAM BC - 4th GRID

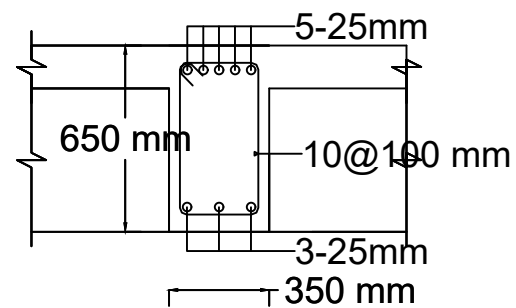

Section at A-A

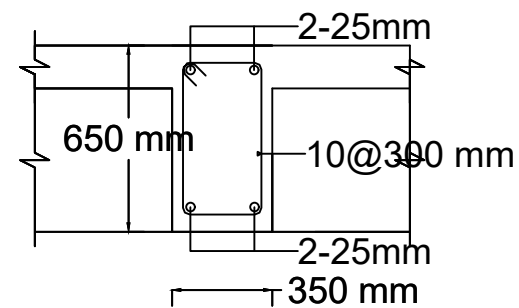

Section at B-B

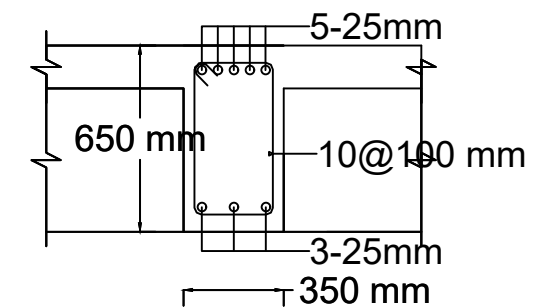

Section at C-C

THIRD FLOOR BEAM CD - 4th GRID

INSTITUTE OF ENGINEERING PULCHOWK CAMPUS PULCHOWK, LALITPUR	PROJECT TITLE	SHEET TITLE	SUBMITTED TO:	SUBMITTED BY:		SCALE: FIT TO SCALE
	EARTHQUAKE RESISTANT ANALYSIS AND DESIGN OF MULTIPURPOSE BUILDING	THIRD FLOOR BEAM SECTIONS OF BUILDING 1	DEPARTMENT OF CIVIL ENGINEERING PULCHOWK CAMPUS	Prakrit Devkota (PUL075BCE101)	Priyanshu Pokhrel (PUL075BCE109)	SHEET NO. 23
				Ram Krishna Kandel (PUL075BCE116)	Rijab Ali Miya (PUL075BCE119)	
				Safal Katwal (PUL075BCE129)	Sangam Poudel (PUL075BCE142)	SUBMISSION DATE: April 2023
			PROJECT SUPERVISOR:	Asst. Prof. Aakarsha Khawas		

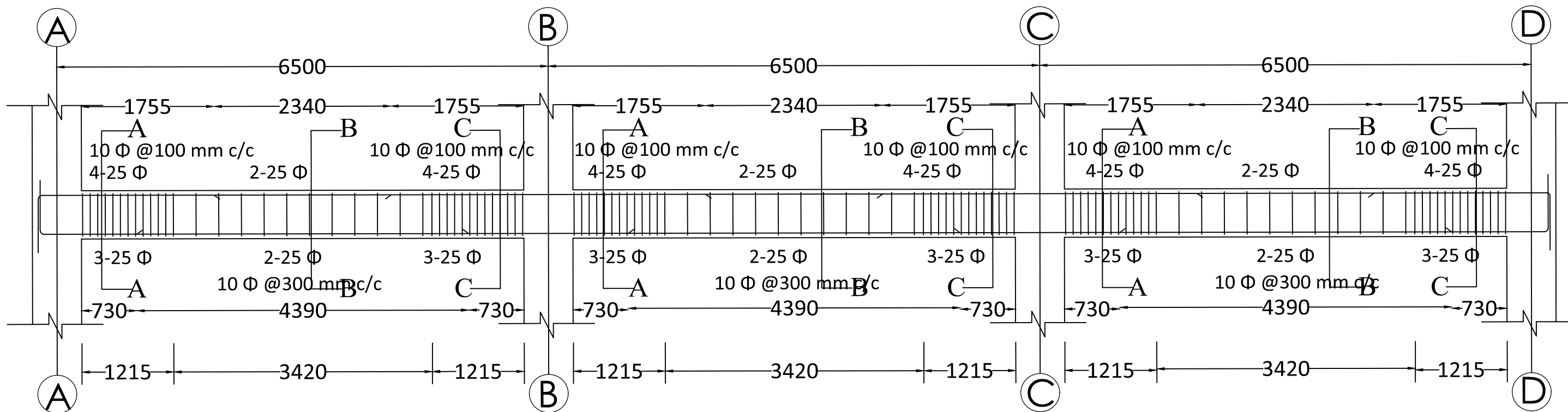

REINFORCEMENT DETAILING GRID 4 4TH FLOOR

INSTITUTE OF ENGINEERING PULCHOWK CAMPUS PULCHOWK, LALITPUR	PROJECT TITLE	SHEET TITLE	SUBMITTED TO:	SUBMITTED BY:		SCALE: FIT TO SCALE
	EARTHQUAKE RESISTANT ANALYSIS AND DESIGN OF MULTIPURPOSE BUILDING	FOURTH FLOOR BEAM DETAILING OF BUILDING 1	DEPARTMENT OF CIVIL ENGINEERING PULCHOWK CAMPUS	Prakrit Devkota (PUL075BCE101)	Priyanshu Pokhrel (PUL075BCE109)	SHEET NO. 24
				Ram Krishna Kandel (PUL075BCE116)	Rijab Ali Miya (PUL075BCE119)	
				Safal Katwal (PUL075BCE129)	Sangam Poudel (PUL075BCE142)	
PROJECT SUPERVISOR:				Asst. Prof. Aakarsha Khawas	SUBMISSION DATE: April 2023	

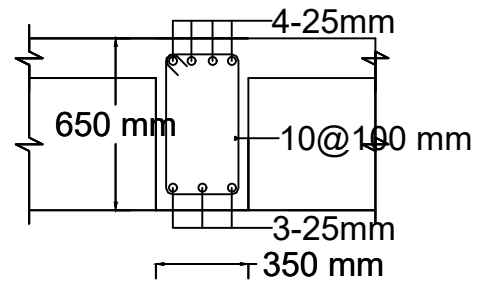

Section at A-A

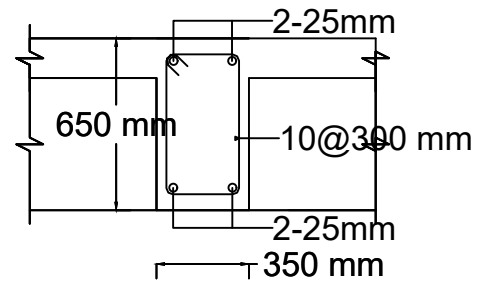

Section at B-B

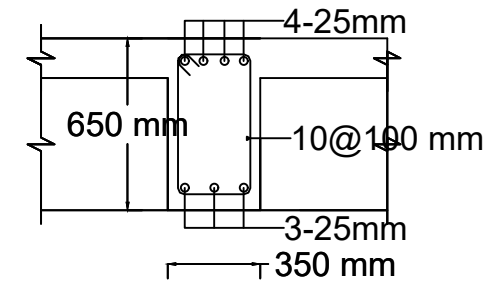

Section at C-C

FOURTH FLOOR BEAM AB - 4th GRID

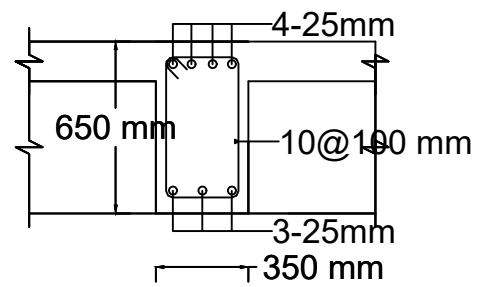

Section at A-A

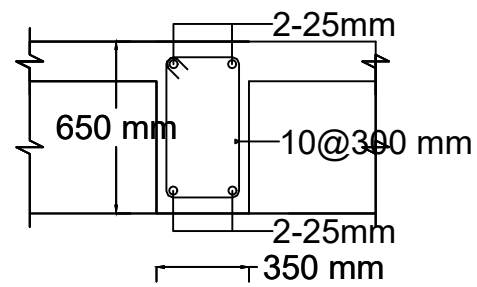

Section at B-B

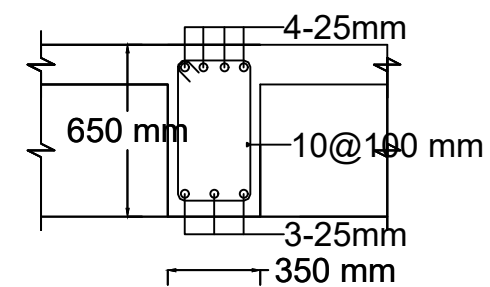

Section at C-C

FOURTH FLOOR BEAM BC - 4th GRID

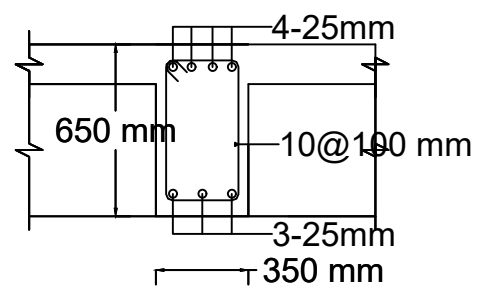

Section at A-A

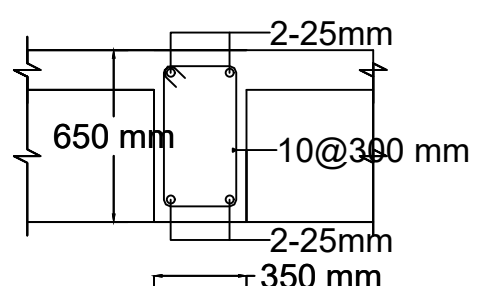

Section at B-B

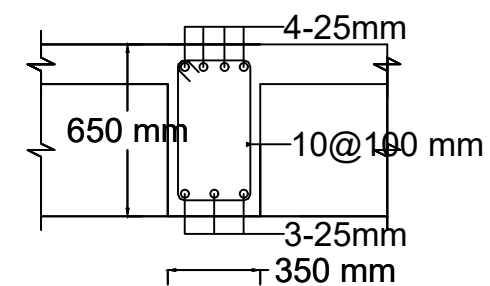

Section at C-C

FOURTH FLOOR BEAM CD - 4th GRID

INSTITUTE OF ENGINEERING PULCHOWK CAMPUS PULCHOWK, LALITPUR	PROJECT TITLE	SHEET TITLE	SUBMITTED TO:	SUBMITTED BY:		SCALE: FIT TO SCALE
	EARTHQUAKE RESISTANT ANALYSIS AND DESIGN OF MULTIPURPOSE BUILDING	FOURTH FLOOR BEAM SECTIONS OF BUILDING 1	DEPARTMENT OF CIVIL ENGINEERING PULCHOWK CAMPUS	Prakrit Devkota (PUL075BCE101)	Priyanshu Pokhrel (PUL075BCE109)	SHEET NO. 25
				Ram Krishna Kandel (PUL075BCE116)	Rijab Ali Miya (PUL075BCE119)	
				Safal Katwal (PUL075BCE129)	Sangam Poudel (PUL075BCE142)	SUBMISSION DATE: April 2023
PROJECT SUPERVISOR:				Asst. Prof. Aakarsha Khawas		

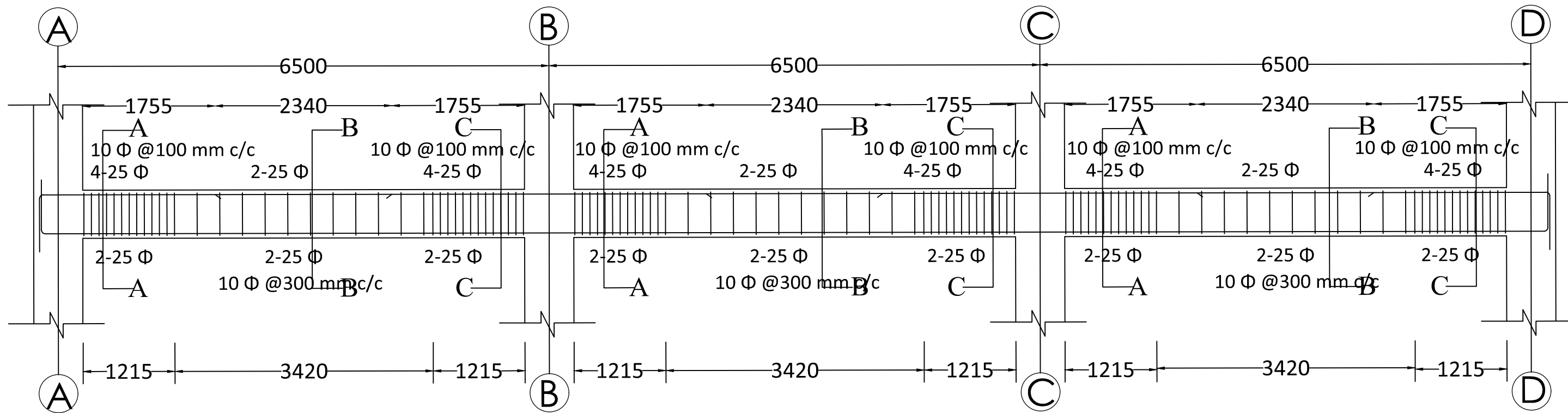

REINFORCEMENT DETAILING GRID 4 5TH FLOOR

INSTITUTE OF ENGINEERING PULCHOWK CAMPUS PULCHOWK, LALITPUR	PROJECT TITLE	SHEET TITLE	SUBMITTED TO:	SUBMITTED BY:		SCALE: FIT TO SCALE
	EARTHQUAKE RESISTANT ANALYSIS AND DESIGN OF MULTIPURPOSE BUILDING	FIFTH FLOOR BEAM DETAILING OF BUILDING 1	DEPARTMENT OF CIVIL ENGINEERING PULCHOWK CAMPUS	Prakrit Devkota (PUL075BCE101)	Priyanshu Pokhrel (PUL075BCE109)	SHEET NO. 26
				Ram Krishna Kandel (PUL075BCE116)	Rijab Ali Miya (PUL075BCE119)	
				Safal Katwal (PUL075BCE129)	Sangam Poudel (PUL075BCE142)	SUBMISSION DATE: April 2023
			PROJECT SUPERVISOR:	Asst. Prof. Aakarsha Khawas		

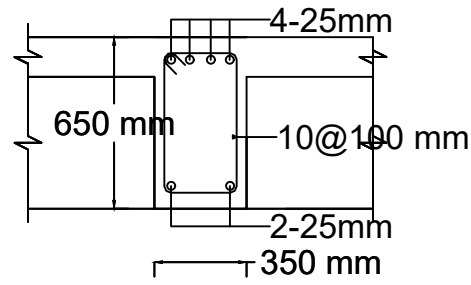

Section at A-A

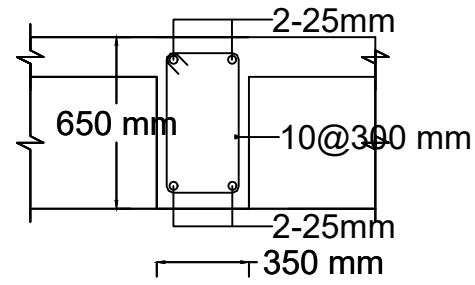

Section at B-B

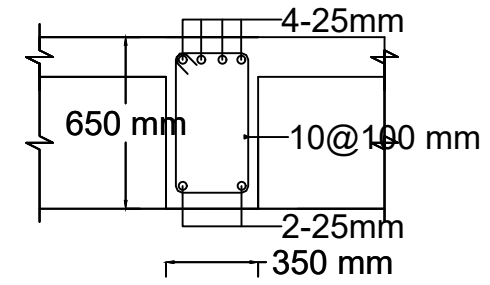

Section at C-C

FIFTH FLOOR BEAM AB - 4th GRID

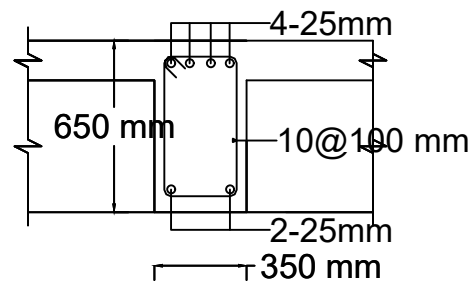

Section at A-A

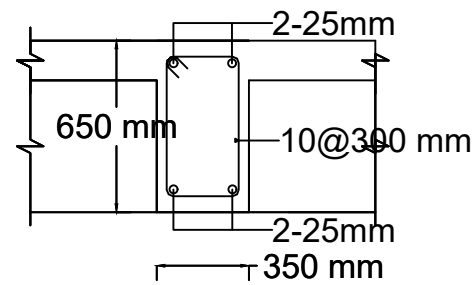

Section at B-B

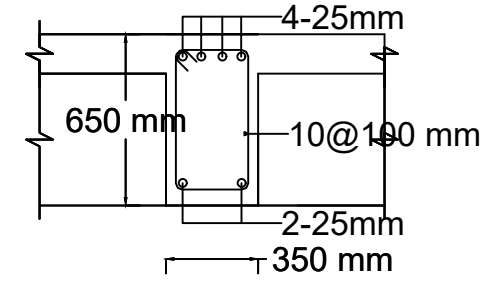

Section at C-C

FIFTH FLOOR BEAM BC - 4th GRID

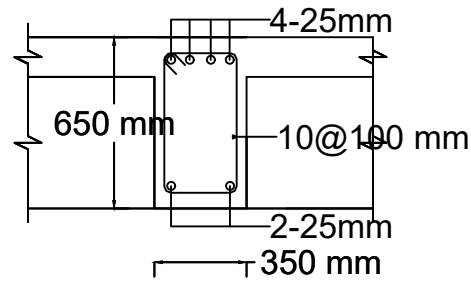

Section at A-A

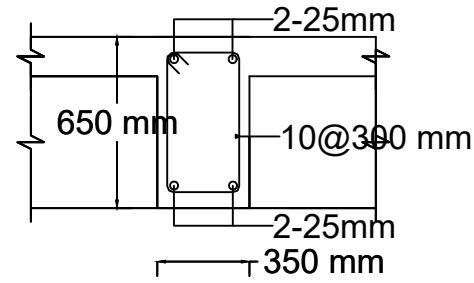

Section at B-B

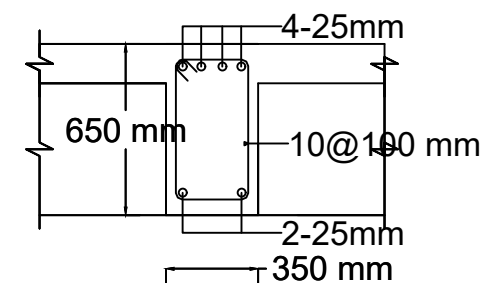

Section at C-C

FIFTH FLOOR BEAM CD - 4th GRID

INSTITUTE OF ENGINEERING PULCHOWK CAMPUS PULCHOWK, LALITPUR	PROJECT TITLE	SHEET TITLE	SUBMITTED TO:	SUBMITTED BY:		SCALE: FIT TO SCALE
	EARTHQUAKE RESISTANT ANALYSIS AND DESIGN OF MULTIPURPOSE BUILDING	FIFTH FLOOR BEAM SECTIONS OF BUILDING 1	DEPARTMENT OF CIVIL ENGINEERING PULCHOWK CAMPUS	Prakrit Devkota (PUL075BCE101)	Priyanshu Pokhrel (PUL075BCE109)	SHEET NO. 27
				Ram Krishna Kandel (PUL075BCE116)	Rijab Ali Miya (PUL075BCE119)	
				Safal Katwal (PUL075BCE129)	Sangam Poudel (PUL075BCE142)	SUBMISSION DATE: April 2023
PROJECT SUPERVISOR:				Asst. Prof. Aakarsha Khawas		

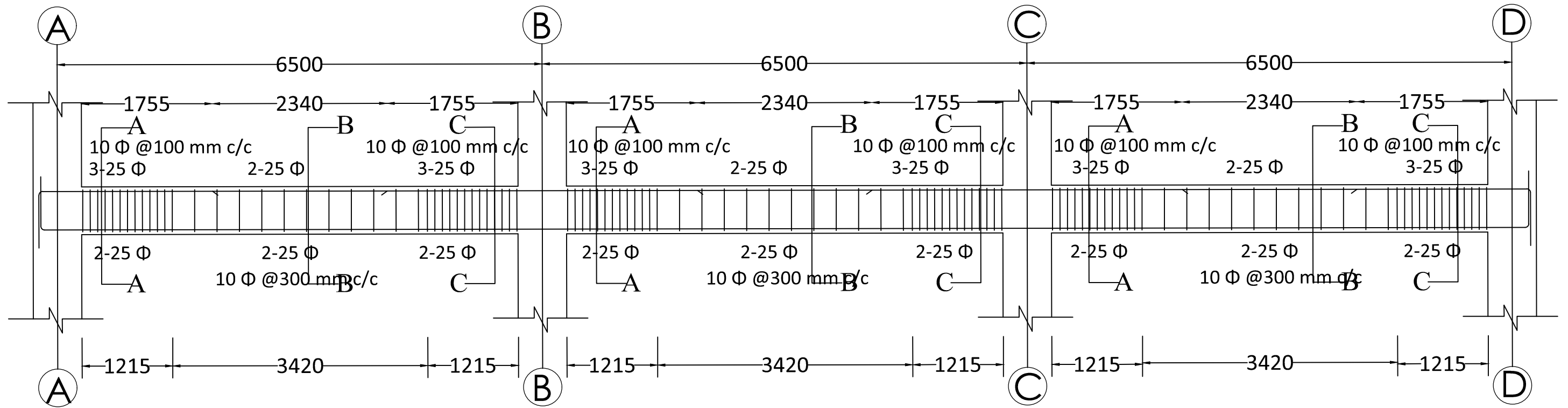

REINFORCEMENT DETAILING GRID 4 6TH FLOOR

INSTITUTE OF ENGINEERING PULCHOWK CAMPUS PULCHOWK, LALITPUR	PROJECT TITLE	SHEET TITLE	SUBMITTED TO:	SUBMITTED BY:		SCALE: FIT TO SCALE
	EARTHQUAKE RESISTANT ANALYSIS AND DESIGN OF MULTIPURPOSE BUILDING	SIXTH FLOOR BEAM DETAILING OF BUILDING 1	DEPARTMENT OF CIVIL ENGINEERING PULCHOWK CAMPUS	Prakrit Devkota (PUL075BCE101)	Priyanshu Pokhrel (PUL075BCE109)	SHEET NO. 28
				Ram Krishna Kandel (PUL075BCE116)	Rijab Ali Miya (PUL075BCE119)	
				Safal Katwal (PUL075BCE129)	Sangam Poudel (PUL075BCE142)	SUBMISSION DATE: April 2023
PROJECT SUPERVISOR:				Asst. Prof. Aakarsha Khawas		

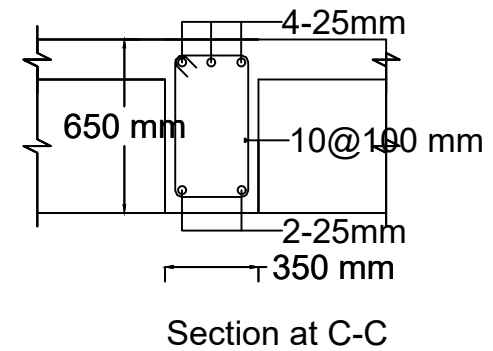
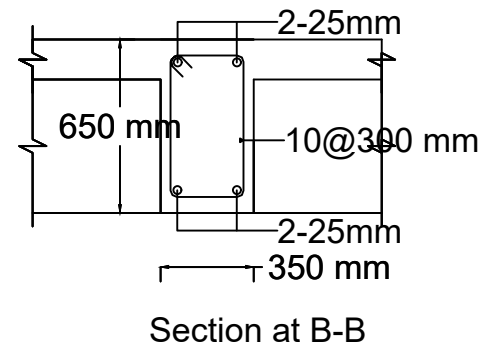
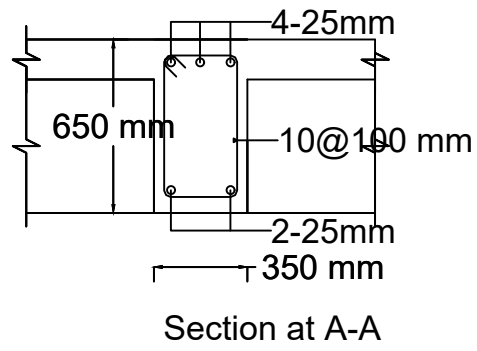

SIXTH FLOOR BEAM AB - 4th GRID

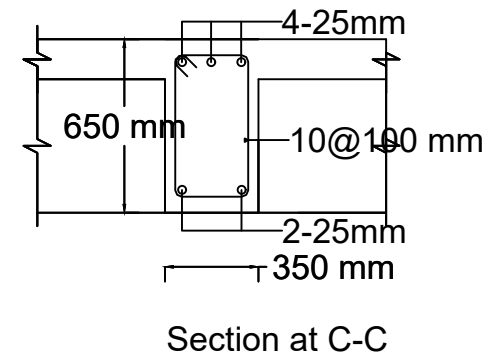
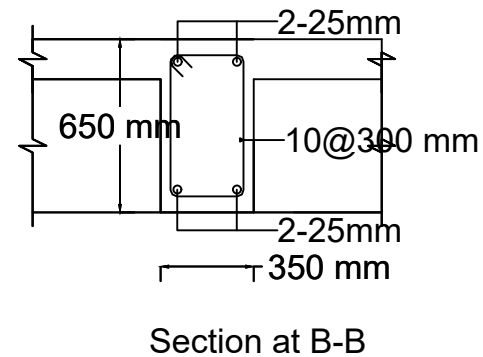
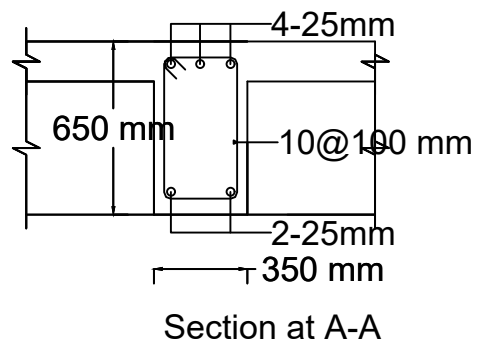

SIXTH FLOOR BEAM BC - 4th GRID

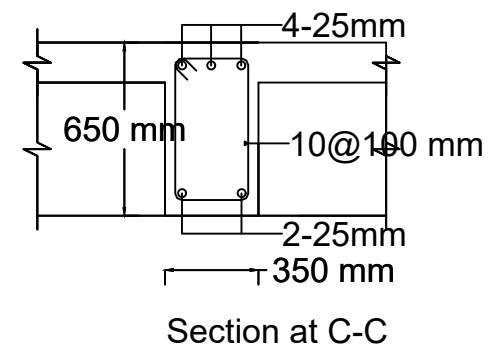
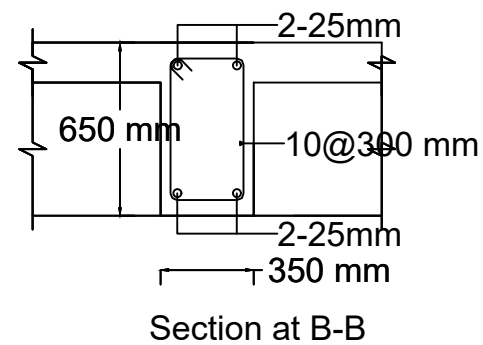
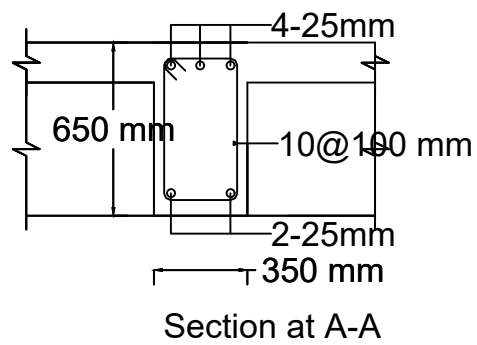

SIXTH FLOOR BEAM CD - 4th GRID

INSTITUTE OF ENGINEERING PULCHOWK CAMPUS PULCHOWK, LALITPUR	PROJECT TITLE	SHEET TITLE	SUBMITTED TO:	SUBMITTED BY:		SCALE: FIT TO SCALE
	EARTHQUAKE RESISTANT ANALYSIS AND DESIGN OF MULTIPURPOSE BUILDING	SIXTH FLOOR BEAM SECTIONS OF BUILDING 1	DEPARTMENT OF CIVIL ENGINEERING PULCHOWK CAMPUS	Prakrit Devkota (PUL075BCE101)	Priyanshu Pokhrel (PUL075BCE109)	SHEET NO. 29
				Ram Krishna Kandel (PUL075BCE116)	Rijab Ali Miya (PUL075BCE119)	
				Safal Katwal (PUL075BCE129)	Sangam Poudel (PUL075BCE142)	SUBMISSION DATE: April 2023
PROJECT SUPERVISOR:				Asst. Prof. Aakarsha Khawas		

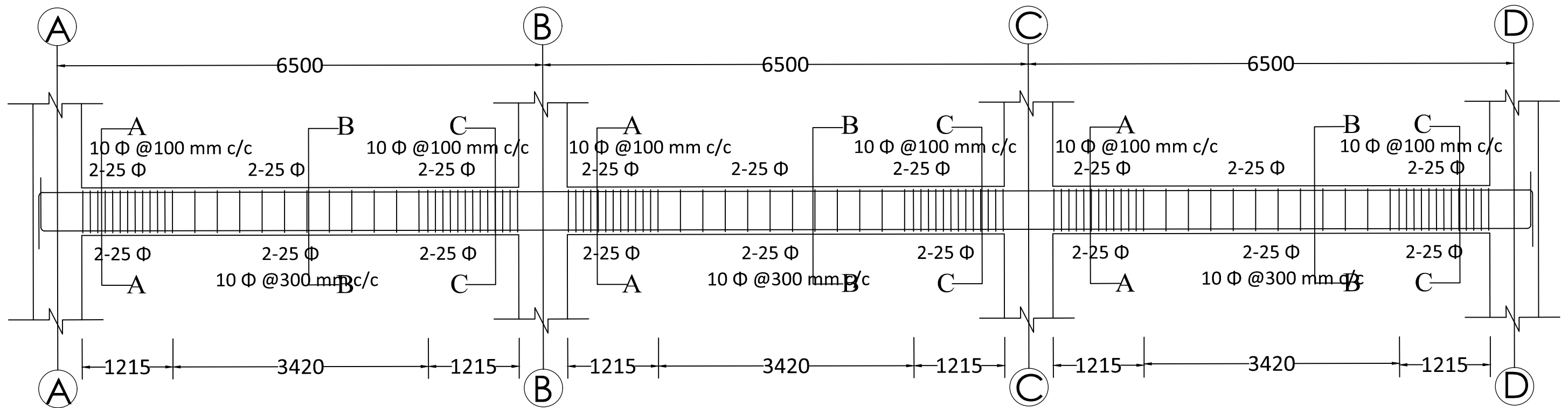

REINFORCEMENT DETAILING GRID 4 TOP FLOOR

INSTITUTE OF ENGINEERING PULCHOWK CAMPUS PULCHOWK, LALITPUR	PROJECT TITLE	SHEET TITLE	SUBMITTED TO:	SUBMITTED BY:		SCALE: FIT TO SCALE
	EARTHQUAKE RESISTANT ANALYSIS AND DESIGN OF MULTIPURPOSE BUILDING	TOP FLOOR BEAM DETAILING OF BUILDING 1	DEPARTMENT OF CIVIL ENGINEERING PULCHOWK CAMPUS	Prakrit Devkota (PUL075BCE101)	Priyanshu Pokhrel (PUL075BCE109)	SHEET NO. 30
				Ram Krishna Kandel (PUL075BCE116)	Rijab Ali Miya (PUL075BCE119)	
				Safal Katwal (PUL075BCE129)	Sangam Poudel (PUL075BCE142)	
PROJECT SUPERVISOR:				Asst. Prof. Aakarsha Khawas	SUBMISSION DATE: April 2023	

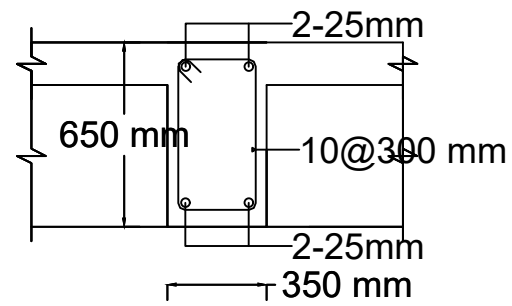

Section at A-A

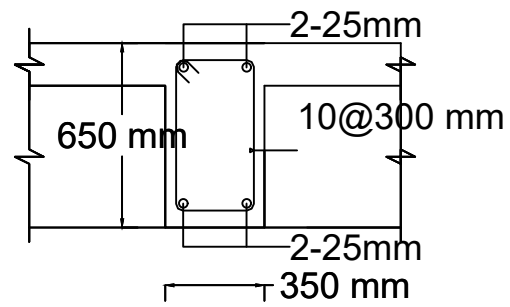

Section at B-B

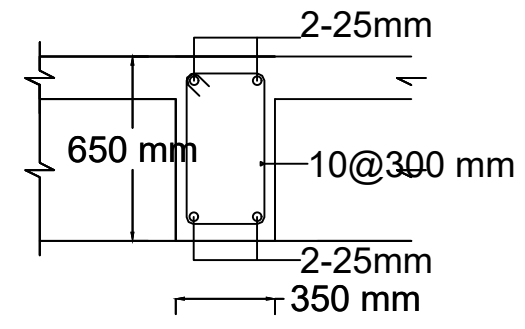

Section at C-C

TOP FLOOR BEAM AB - 4th GRID

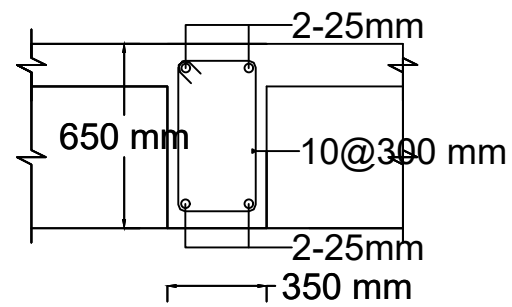

Section at A-A

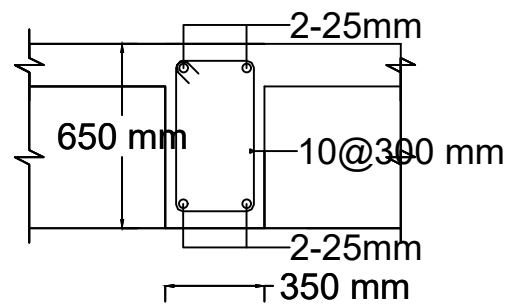

Section at B-B

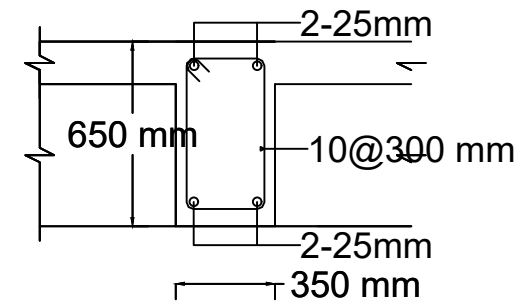

Section at C-C

TOP FLOOR BEAM BC - 4th GRID

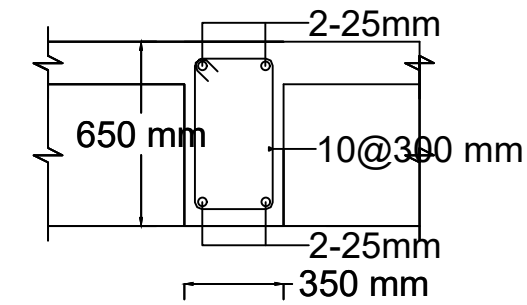

Section at A-A

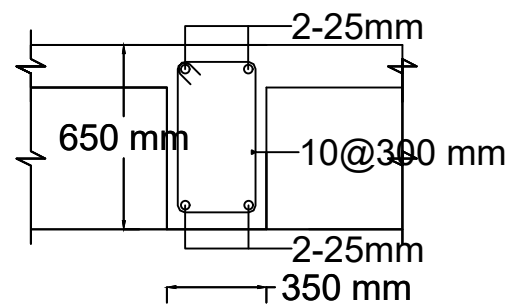

Section at B-B

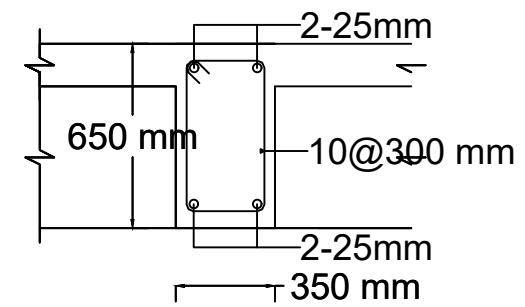

Section at C-C

TOP FLOOR BEAM CD - 4th GRID

INSTITUTE OF ENGINEERING PULCHOWK CAMPUS PULCHOWK, LALITPUR	PROJECT TITLE	SHEET TITLE	SUBMITTED TO:	SUBMITTED BY:		SCALE: FIT TO SCALE
	EARTHQUAKE RESISTANT ANALYSIS AND DESIGN OF MULTIPURPOSE BUILDING	TOP FLOOR BEAM SECTIONS OF BUILDING 1	DEPARTMENT OF CIVIL ENGINEERING PULCHOWK CAMPUS	Prakrit Devkota (PUL075BCE101)	Priyanshu Pokhrel (PUL075BCE109)	SHEET NO. 31
				Ram Krishna Kandel (PUL075BCE116)	Rijab Ali Miya (PUL075BCE119)	
				Safal Katwal (PUL075BCE129)	Sangam Poudel (PUL075BCE142)	SUBMISSION DATE: April 2023
			PROJECT SUPERVISOR:	Asst. Prof. Aakarsha Khawas		

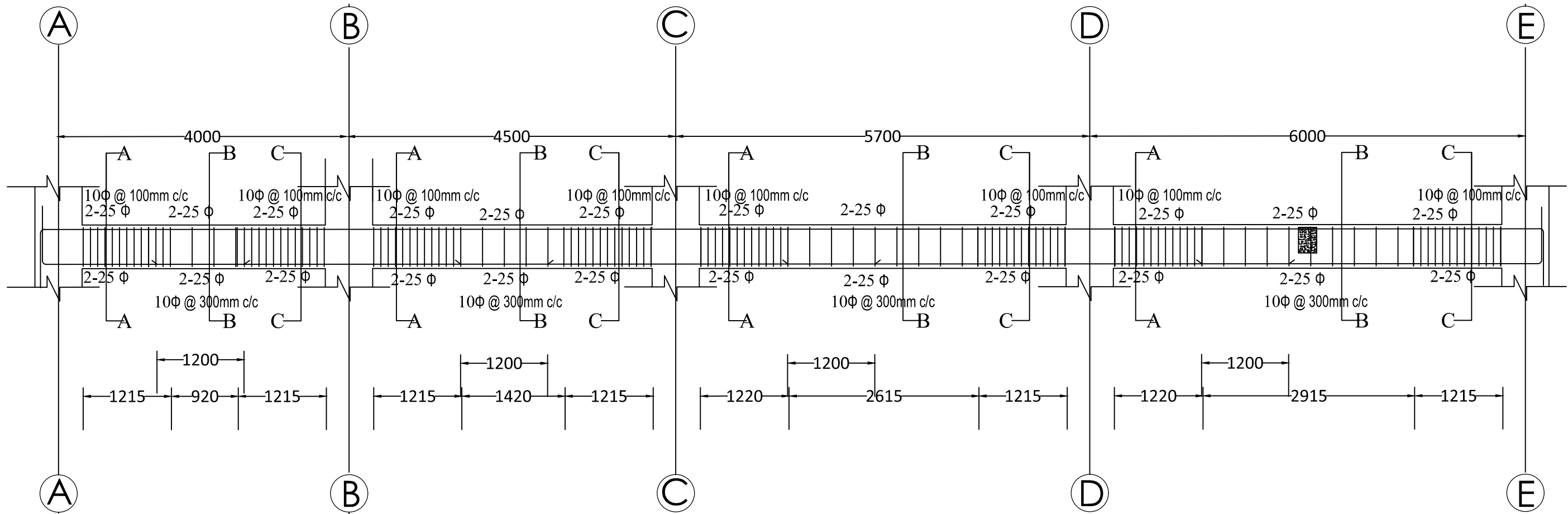

REINFORCEMENT DETAILING GRID 4 GROUND FLOOR

INSTITUTE OF ENGINEERING PULCHOWK CAMPUS PULCHOWK, LALITPUR	PROJECT TITLE	SHEET TITLE	SUBMITTED TO:	SUBMITTED BY:		SCALE: FIT TO SCALE
	EARTHQUAKE RESISTANT ANALYSIS AND DESIGN OF MULTIPURPOSE BUILDING	GROUND FLOOR BEAM DETAILING OF BUILDING 2	DEPARTMENT OF CIVIL ENGINEERING PULCHOWK CAMPUS	Prakrit Devkota (PUL075BCE101)	Priyanshu Pokhrel (PUL075BCE109)	SHEET NO. 32
				Ram Krishna Kandel (PUL075BCE116)	Rijab Ali Miya (PUL075BCE119)	
				Safal Katwal (PUL075BCE129)	Sangam Poudel (PUL075BCE142)	SUBMISSION DATE: April 2023
			PROJECT SUPERVISOR:	Asst. Prof. Aakarsha Khawas		

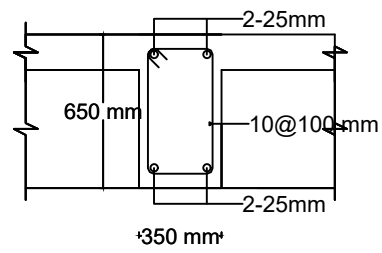

Section at A-A

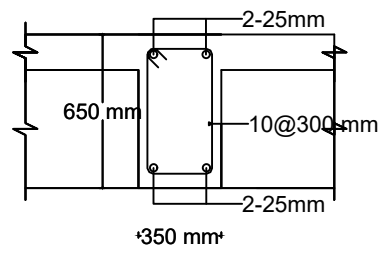

Section at B-B

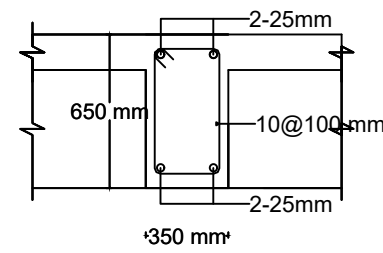

Section at C-C

GROUND FLOOR BEAM AB - 4th GRID

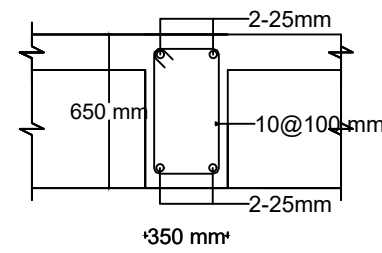

Section at A-A

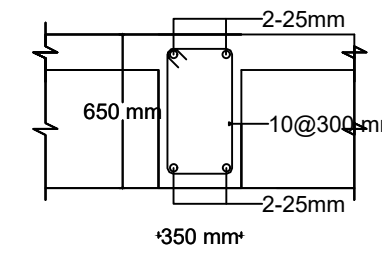

Section at B-B

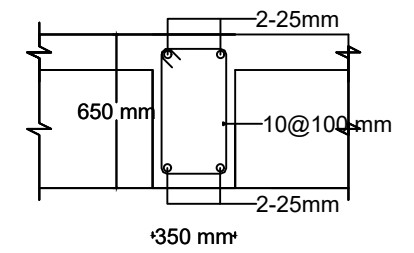

Section at C-C

GROUND FLOOR BEAM CD - 4th GRID

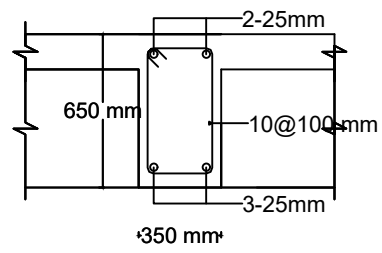

Section at A-A

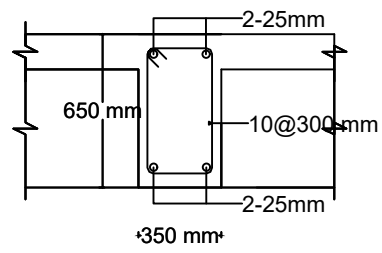

Section at B-B

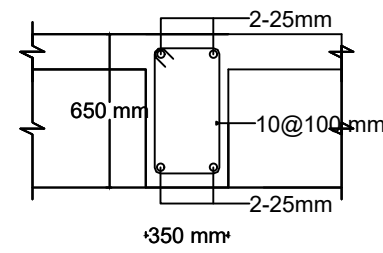

Section at C-C

GROUND FLOOR BEAM BC - 4th GRID

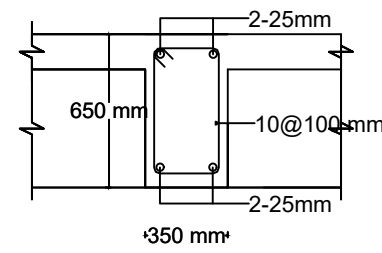

Section at A-A

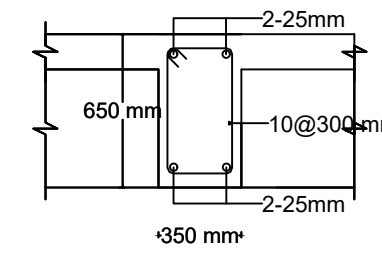

Section at B-B

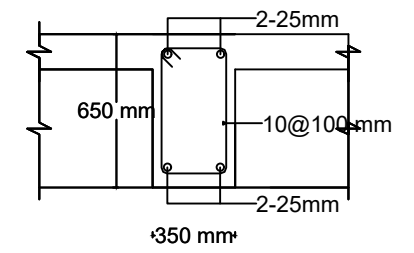

Section at C-C

GROUND FLOOR BEAM DE- 4th GRID

INSTITUTE OF ENGINEERING PULCHOWK CAMPUS PULCHOWK, LALITPUR	PROJECT TITLE	SHEET TITLE	SUBMITTED TO:	SUBMITTED BY:		SCALE: FIT TO SCALE
	EARTHQUAKE RESISTANT ANALYSIS AND DESIGN OF MULTIPURPOSE BUILDING	GROUND FLOOR BEAM SECTIONS OF BUILDING 2	DEPARTMENT OF CIVIL ENGINEERING PULCHOWK CAMPUS	Prakrit Devkota (PUL075BCE101)	Priyanshu Pokhrel (PUL075BCE109)	SHEET NO. 33
				Ram Krishna Kandel (PUL075BCE116)	Rijab Ali Miya (PUL075BCE119)	
				Safal Katwal (PUL075BCE129)	Sangam Poudel (PUL075BCE142)	SUBMISSION DATE: April 2023
			PROJECT SUPERVISOR:	Asst. Prof. Aakarsha Khawas		

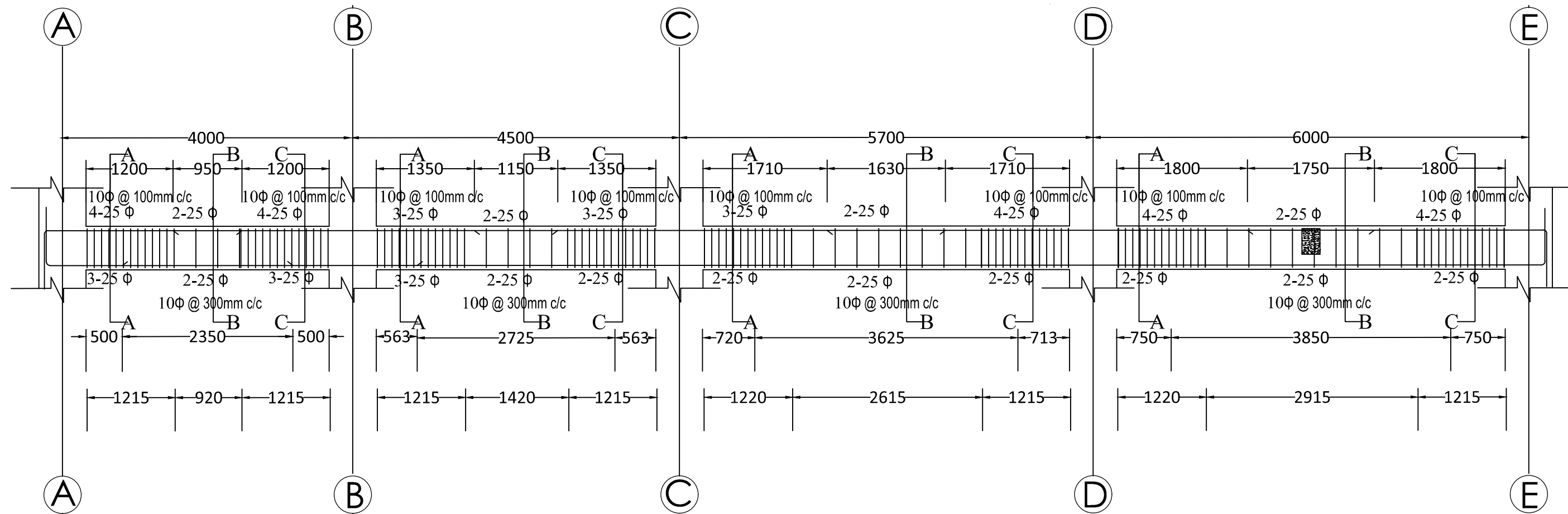

REINFORCEMENT DETAILING GRID 4 1ST FLOOR

INSTITUTE OF ENGINEERING PULCHOWK CAMPUS PULCHOWK, LALITPUR	PROJECT TITLE	SHEET TITLE	SUBMITTED TO:	SUBMITTED BY:		SCALE: FIT TO SCALE
	EARTHQUAKE RESISTANT ANALYSIS AND DESIGN OF MULTIPURPOSE BUILDING	FIRST FLOOR BEAM DETAILING OF BUILDING 2	DEPARTMENT OF CIVIL ENGINEERING PULCHOWK CAMPUS	Prakrit Devkota (PUL075BCE101)	Priyanshu Pokhrel (PUL075BCE109)	SHEET NO. 34
				Ram Krishna Kandel (PUL075BCE116)	Rijab Ali Miya (PUL075BCE119)	
				Safal Katwal (PUL075BCE129)	Sangam Poudel (PUL075BCE142)	SUBMISSION DATE: April 2023
			PROJECT SUPERVISOR:	Asst. Prof. Aakarsha Khawas		

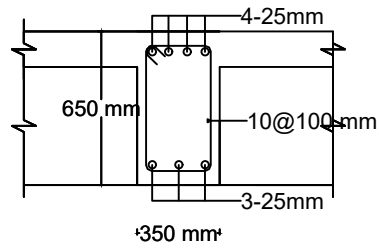

Section at A-A

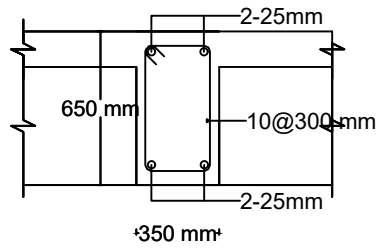

Section at B-B

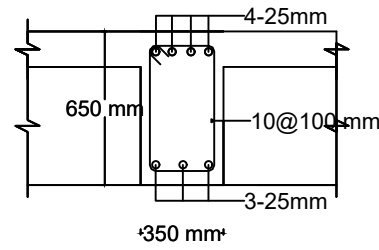

Section at C-C

FIRST FLOOR BEAM AB - 4th GRID

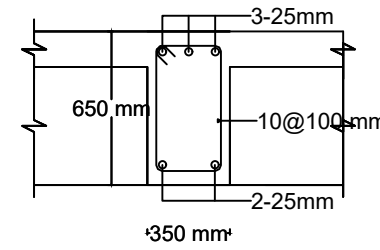

Section at A-A

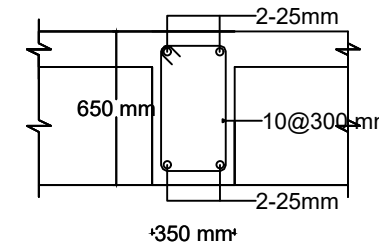

Section at B-B

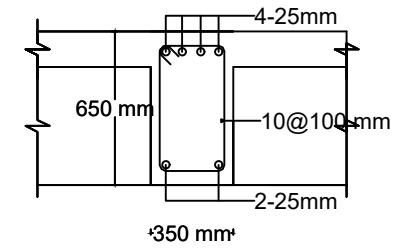

Section at C-C

FIRST FLOOR BEAM CD - 4th GRID

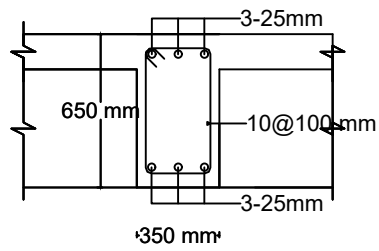

Section at A-A

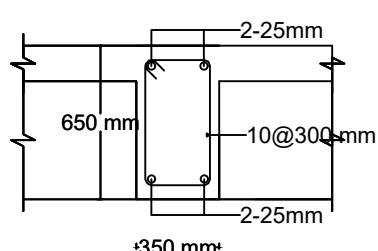

Section at B-B

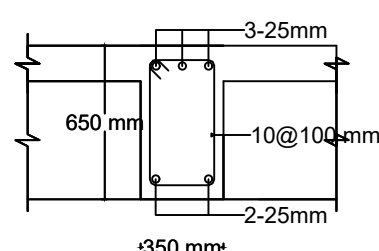

Section at C-C

FIRST FLOOR BEAM BC - 4th GRID

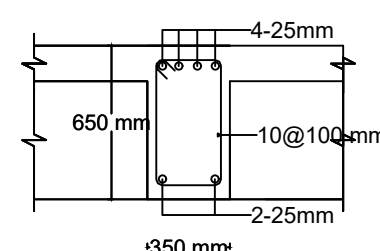

Section at A-A

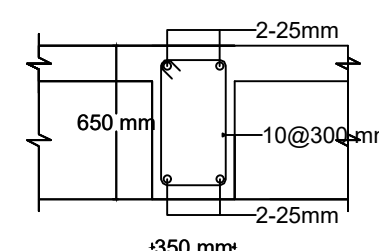

Section at B-B

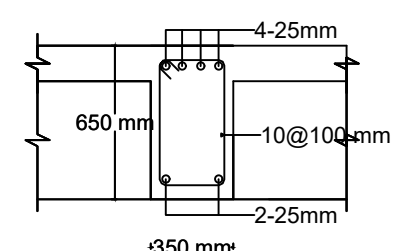

Section at C-C

FIRST FLOOR BEAM DE- 4th GRID

INSTITUTE OF ENGINEERING PULCHOWK CAMPUS PULCHOWK, LALITPUR	PROJECT TITLE	SHEET TITLE	SUBMITTED TO:	SUBMITTED BY:		SCALE: FIT TO SCALE
	EARTHQUAKE RESISTANT ANALYSIS AND DESIGN OF MULTIPURPOSE BUILDING	FIRST FLOOR BEAM SECTIONS OF BUILDING 2	DEPARTMENT OF CIVIL ENGINEERING PULCHOWK CAMPUS	Prakrit Devkota (PUL075BCE101)	Priyanshu Pokhrel (PUL075BCE109)	SHEET NO. 35
				Ram Krishna Kandel (PUL075BCE116)	Rijab Ali Miya (PUL075BCE119)	
				Safal Katwal (PUL075BCE129)	Sangam Poudel (PUL075BCE142)	SUBMISSION DATE: April 2023
			PROJECT SUPERVISOR:	Asst. Prof. Aakarsha Khawas		

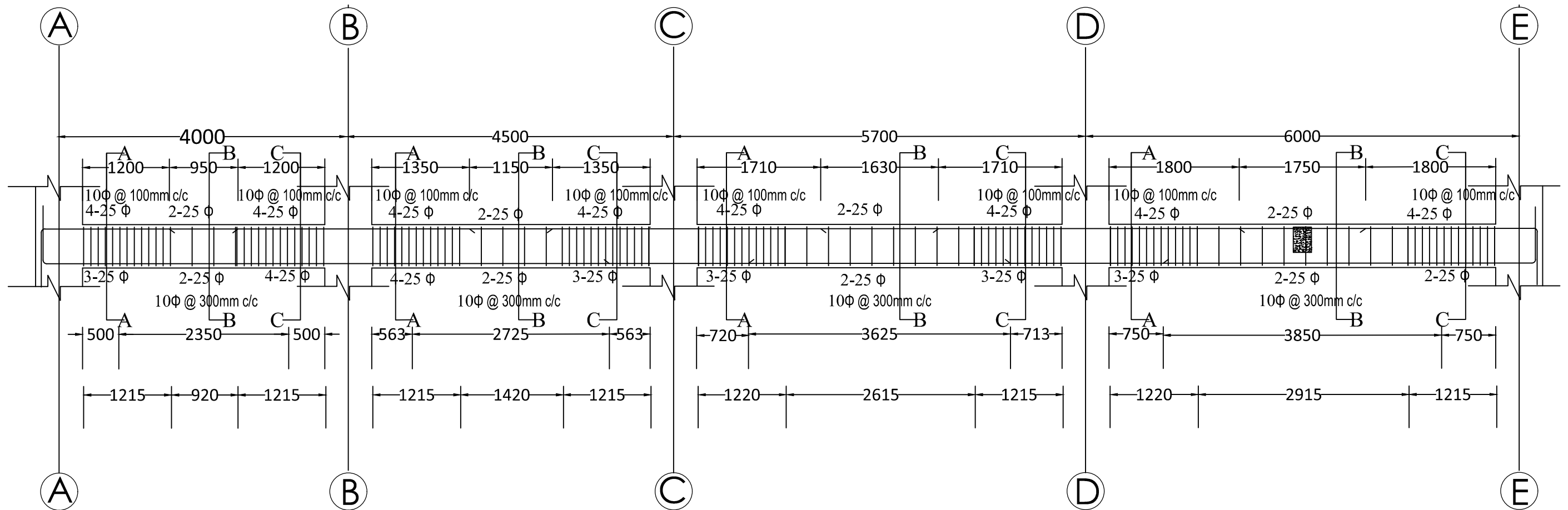

REINFORCEMENT DETAILING GRID 4 2ND FLOOR

INSTITUTE OF ENGINEERING PULCHOWK CAMPUS PULCHOWK, LALITPUR	PROJECT TITLE	SHEET TITLE	SUBMITTED TO:	SUBMITTED BY:		SCALE: FIT TO SCALE
	EARTHQUAKE RESISTANT ANALYSIS AND DESIGN OF MULTIPURPOSE BUILDING	SECOND FLOOR BEAM DETAILING OF BUILDING 2	DEPARTMENT OF CIVIL ENGINEERING PULCHOWK CAMPUS	Prakrit Devkota (PUL075BCE101)	Priyanshu Pokhrel (PUL075BCE109)	SHEET NO. 36
				Ram Krishna Kandel (PUL075BCE116)	Rijab Ali Miya (PUL075BCE119)	
				Safal Katwal (PUL075BCE129)	Sangam Poudel (PUL075BCE142)	SUBMISSION DATE:
			PROJECT SUPERVISOR:	Asst. Prof. Aakarsha Khawas	April 2023	

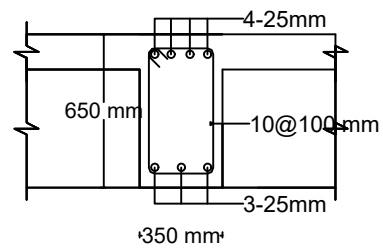

Section at A-A

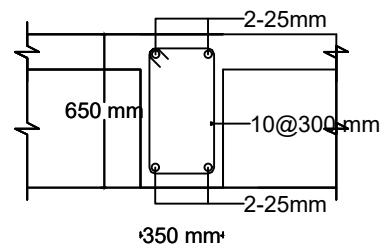

Section at B-B

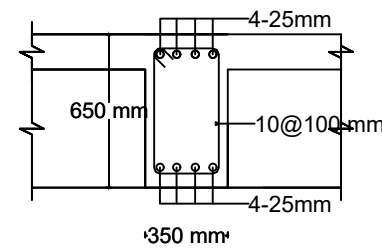

Section at C-C

SECOND FLOOR BEAM AB - 4th GRID

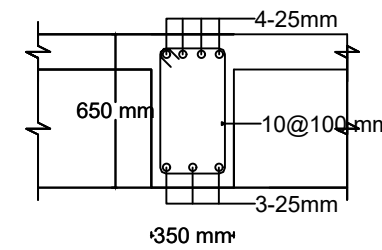

Section at A-A

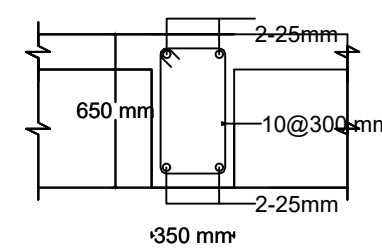

Section at B-B

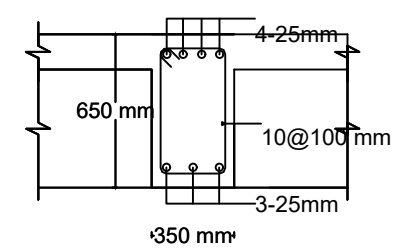

Section at C-C

SECOND FLOOR BEAM CD - 4th GRID

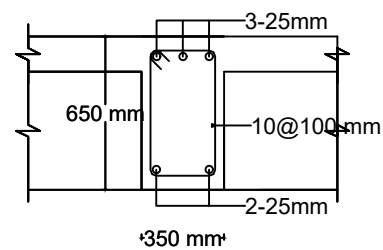

Section at A-A

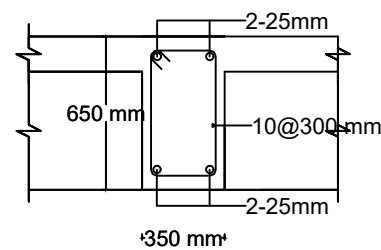

Section at B-B

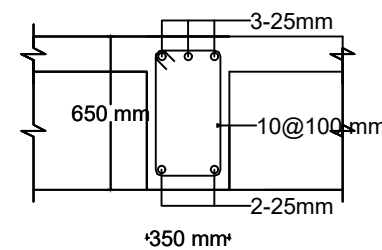

Section at C-C

SECOND FLOOR BEAM BC - 4th GRID

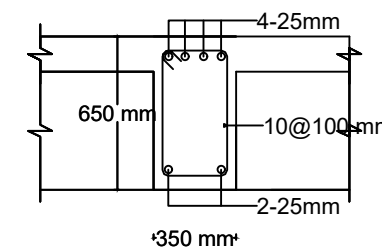

Section at A-A

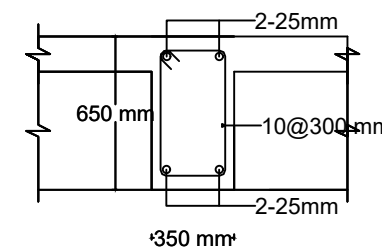

Section at B-B

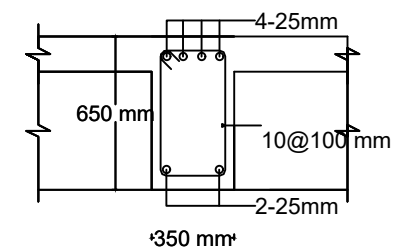

Section at C-C

SECOND FLOOR BEAM DE- 4th GRID

INSTITUTE OF ENGINEERING PULCHOWK CAMPUS PULCHOWK, LALITPUR	PROJECT TITLE	SHEET TITLE	SUBMITTED TO:	SUBMITTED BY:		SCALE: FIT TO SCALE
	EARTHQUAKE RESISTANT ANALYSIS AND DESIGN OF MULTIPURPOSE BUILDING	SECOND FLOOR BEAM SECTIONS OF BUILDING 2	DEPARTMENT OF CIVIL ENGINEERING PULCHOWK CAMPUS	Prakrit Devkota (PUL075BCE101)	Priyanshu Pokhrel (PUL075BCE109)	SHEET NO. 37
				Ram Krishna Kandel (PUL075BCE116)	Rijab Ali Miya (PUL075BCE119)	
				Safal Katwal (PUL075BCE129)	Sangam Poudel (PUL075BCE142)	SUBMISSION DATE: April 2023
			PROJECT SUPERVISOR:	Asst. Prof. Aakarsha Khawas		

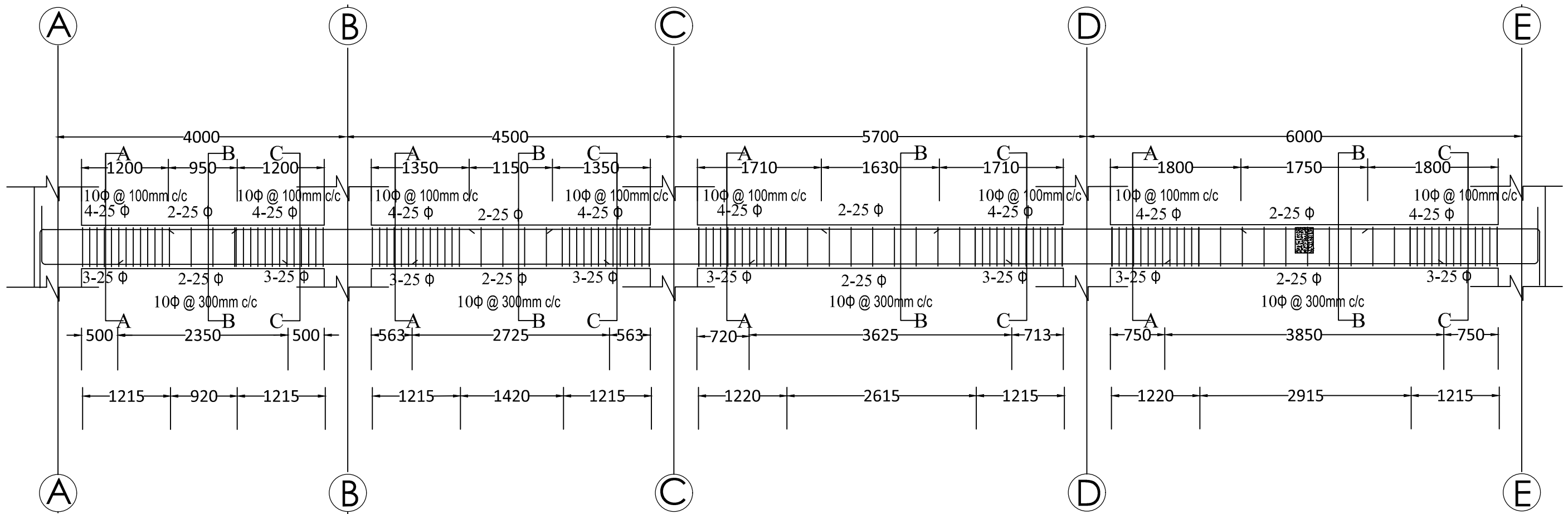

REINFORCEMENT DETAILING GRID 4 3RD FLOOR

INSTITUTE OF ENGINEERING PULCHOWK CAMPUS PULCHOWK, LALITPUR	PROJECT TITLE	SHEET TITLE	SUBMITTED TO:	SUBMITTED BY:		SCALE: FIT TO SCALE
	EARTHQUAKE RESISTANT ANALYSIS AND DESIGN OF MULTIPURPOSE BUILDING	THIRD FLOOR BEAM DETAILING OF BUILDING 2	DEPARTMENT OF CIVIL ENGINEERING PULCHOWK CAMPUS	Prakrit Devkota (PUL075BCE101)	Priyanshu Pokhrel (PUL075BCE109)	SHEET NO. 38
				Ram Krishna Kandel (PUL075BCE116)	Rijab Ali Miya (PUL075BCE119)	
				Safal Katwal (PUL075BCE129)	Sangam Poudel (PUL075BCE142)	SUBMISSION DATE: April 2023
			PROJECT SUPERVISOR:	Asst. Prof. Aakarsha Khawas		

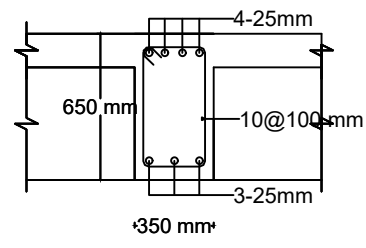

Section at A-A

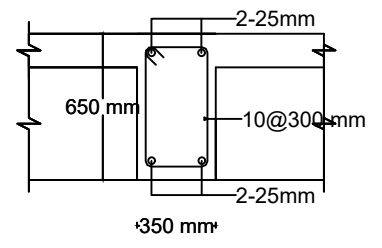

Section at B-B

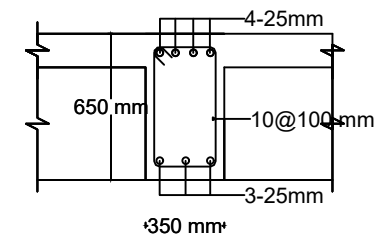

Section at C-C

THIRD FLOOR BEAM AB - 4th GRID

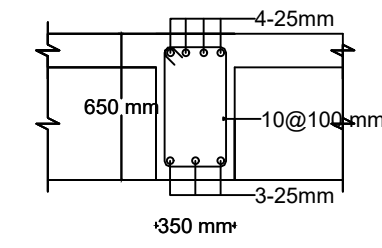

Section at A-A

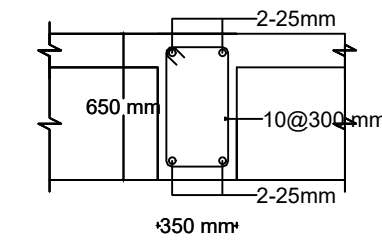

Section at B-B

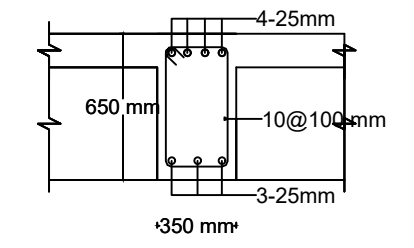

Section at C-C

THIRD FLOOR BEAM CD - 4th GRID

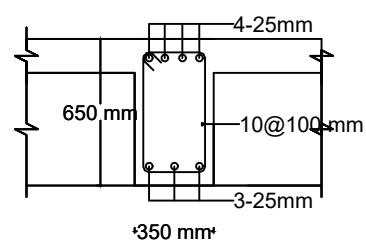

Section at A-A

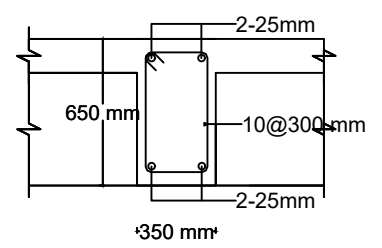

Section at B-B

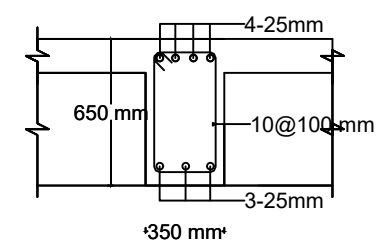

Section at C-C

THIRD FLOOR BEAM BC - 4th GRID

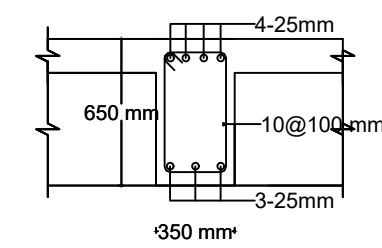

Section at A-A

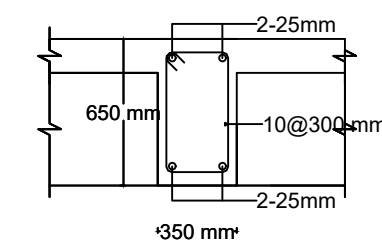

Section at B-B

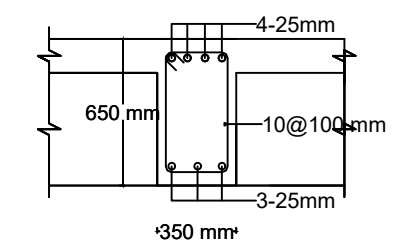

Section at C-C

THIRD FLOOR BEAM DE - 4th GRID

INSTITUTE OF ENGINEERING PULCHOWK CAMPUS PULCHOWK, LALITPUR	PROJECT TITLE	SHEET TITLE	SUBMITTED TO:	SUBMITTED BY:		SCALE: FIT TO SCALE
	EARTHQUAKE RESISTANT ANALYSIS AND DESIGN OF MULTIPURPOSE BUILDING	THIRD FLOOR BEAM SECTIONS OF BUILDING 2	DEPARTMENT OF CIVIL ENGINEERING PULCHOWK CAMPUS	Prakrit Devkota (PUL075BCE101)	Priyanshu Pokhrel (PUL075BCE109)	SHEET NO. 39
				Ram Krishna Kandel (PUL075BCE116)	Rijab Ali Miya (PUL075BCE119)	
				Safal Katwal (PUL075BCE129)	Sangam Poudel (PUL075BCE142)	SUBMISSION DATE: April 2023
			PROJECT SUPERVISOR:	Asst. Prof. Aakarsha Khawas		

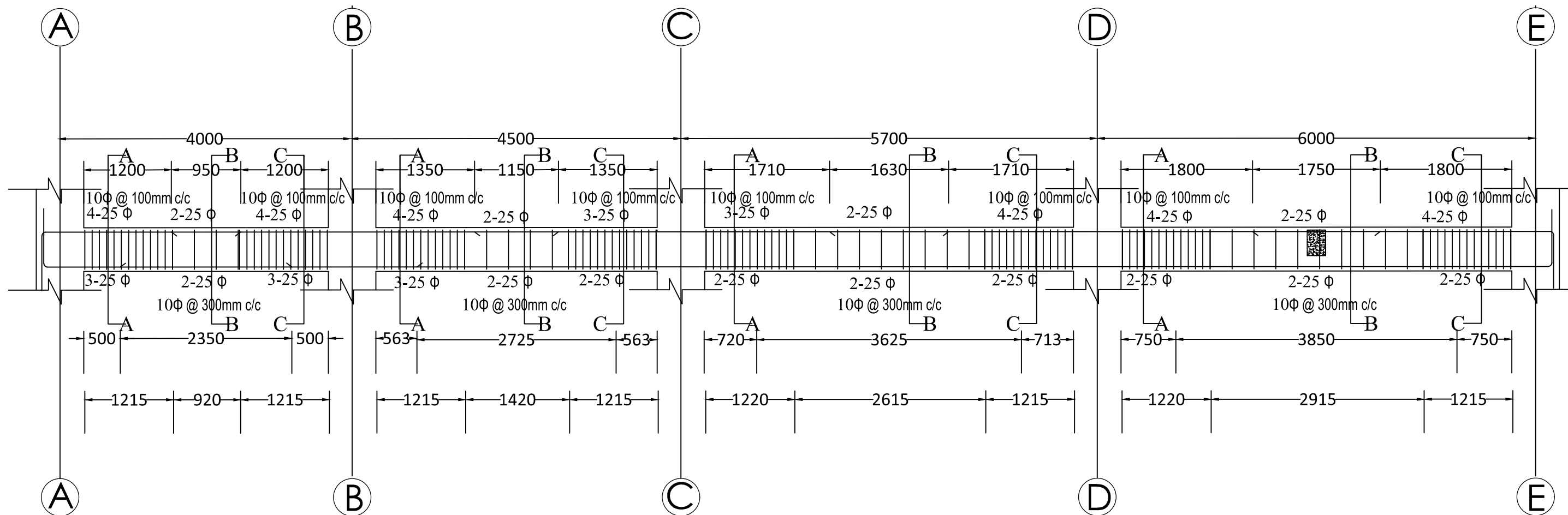

REINFORCEMENT DETAILING GRID 4 4TH FLOOR

INSTITUTE OF ENGINEERING PULCHOWK CAMPUS PULCHOWK, LALITPUR	PROJECT TITLE	SHEET TITLE	SUBMITTED TO:	SUBMITTED BY:		SCALE: FIT TO SCALE
	EARTHQUAKE RESISTANT ANALYSIS AND DESIGN OF MULTIPURPOSE BUILDING	FOURTH FLOOR BEAM DETAILING OF BUILDING 2	DEPARTMENT OF CIVIL ENGINEERING PULCHOWK CAMPUS	Prakrit Devkota (PUL075BCE101)	Priyanshu Pokhrel (PUL075BCE109)	SHEET NO. 40
				Ram Krishna Kandel (PUL075BCE116)	Rijab Ali Miya (PUL075BCE119)	
				Safal Katwal (PUL075BCE129)	Sangam Poudel (PUL075BCE142)	SUBMISSION DATE: April 2023
			PROJECT SUPERVISOR:	Asst. Prof. Aakarsha Khawas		

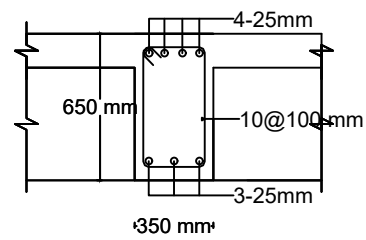

Section at A-A

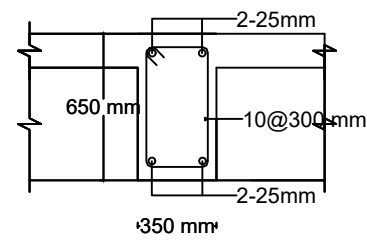

Section at B-B

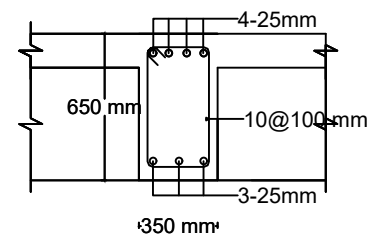

Section at C-C

FOURTH FLOOR BEAM AB - 4th GRID

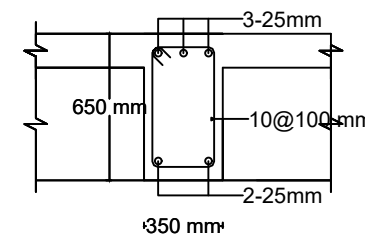

Section at A-A

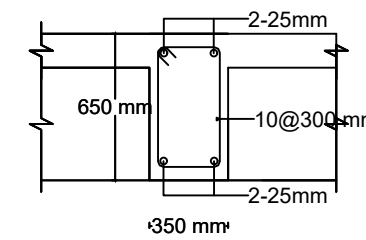

Section at B-B

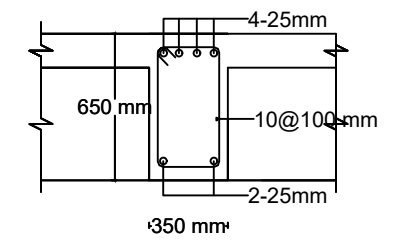

Section at C-C

FOURTH FLOOR BEAM CD - 4th GRID

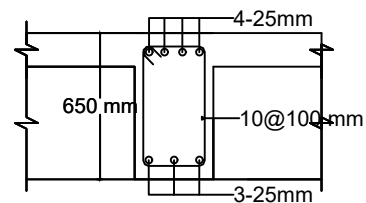

Section at A-A

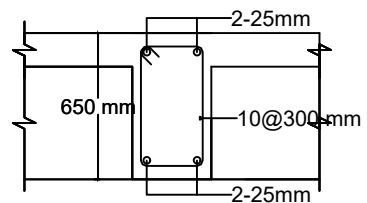

Section at B-B

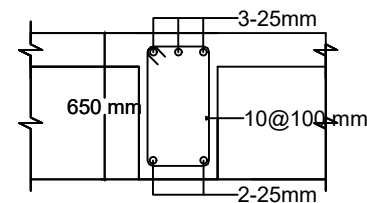

Section at C-C

FOURTH FLOOR BEAM BC - 4th GRID

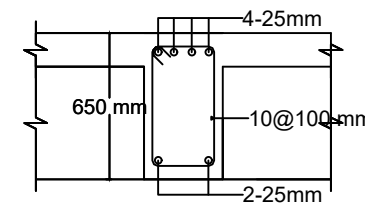

Section at A-A

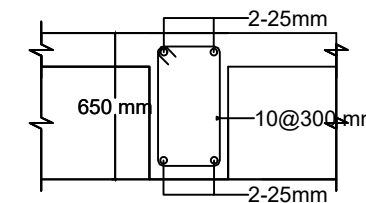

Section at B-B

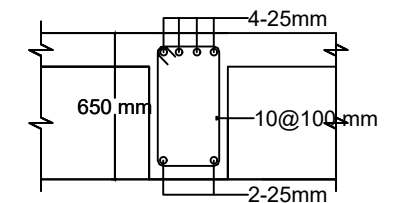

Section at C-C

FOURTH FLOOR BEAM DE - 4th GRID

INSTITUTE OF ENGINEERING PULCHOWK CAMPUS PULCHOWK, LALITPUR	PROJECT TITLE	SHEET TITLE	SUBMITTED TO:	SUBMITTED BY:		SCALE: FIT TO SCALE
	EARTHQUAKE RESISTANT ANALYSIS AND DESIGN OF MULTIPURPOSE BUILDING	FOURTH FLOOR BEAM SECTIONS OF BUILDING 2	DEPARTMENT OF CIVIL ENGINEERING PULCHOWK CAMPUS	Prakrit Devkota (PUL075BCE101)	Priyanshu Pokhrel (PUL075BCE109)	SHEET NO. 41
				Ram Krishna Kandel (PUL075BCE116)	Rijab Ali Miya (PUL075BCE119)	
				Safal Katwal (PUL075BCE129)	Sangam Poudel (PUL075BCE142)	SUBMISSION DATE: April 2023
			PROJECT SUPERVISOR:	Asst. Prof. Aakarsha Khawas		

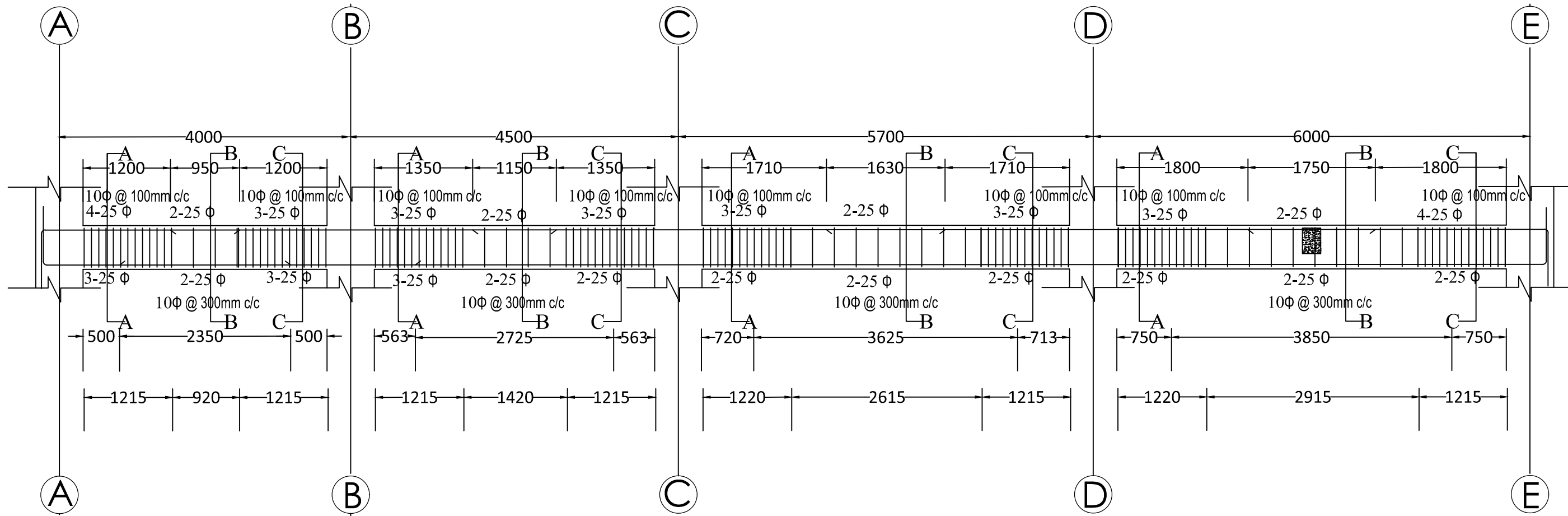

REINFORCEMENT DETAILING GRID 4 5TH FLOOR

INSTITUTE OF ENGINEERING PULCHOWK CAMPUS PULCHOWK, LALITPUR	PROJECT TITLE	SHEET TITLE	SUBMITTED TO:	SUBMITTED BY:		SCALE: FIT TO SCALE
	EARTHQUAKE RESISTANT ANALYSIS AND DESIGN OF MULTIPURPOSE BUILDING	FIFTH FLOOR BEAM DETAILING OF BUILDING 2	DEPARTMENT OF CIVIL ENGINEERING PULCHOWK CAMPUS	Prakrit Devkota (PUL075BCE101)	Priyanshu Pokhrel (PUL075BCE109)	SHEET NO. 42
				Ram Krishna Kandel (PUL075BCE116)	Rijab Ali Miya (PUL075BCE119)	
				Safal Katwal (PUL075BCE129)	Sangam Poudel (PUL075BCE142)	SUBMISSION DATE: April 2023
PROJECT SUPERVISOR:	Asst. Prof. Aakarsha Khawas					

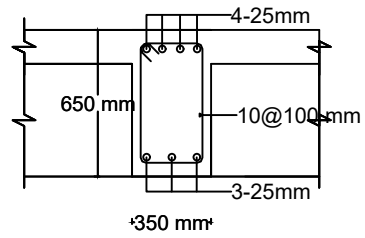

Section at A-A

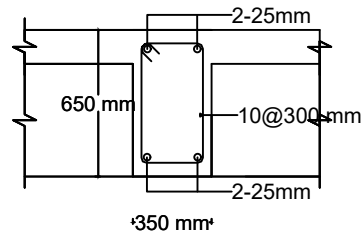

Section at B-B

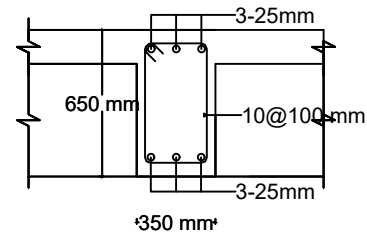

Section at C-C

FIFTH FLOOR BEAM AB - 4th GRID

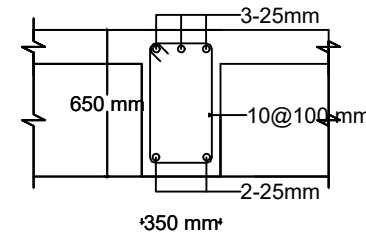

Section at A-A

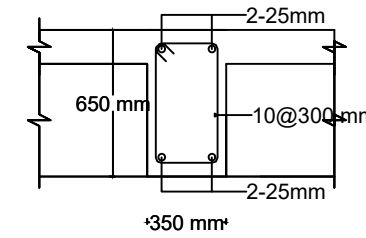

Section at B-B

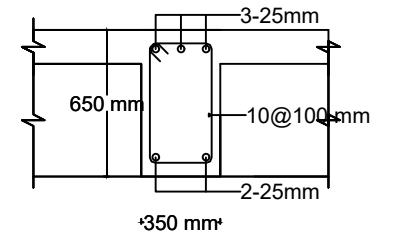

Section at C-C

FIFTH FLOOR BEAM CD - 4th GRID

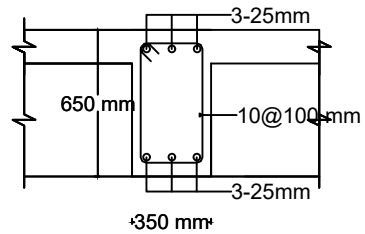

Section at A-A

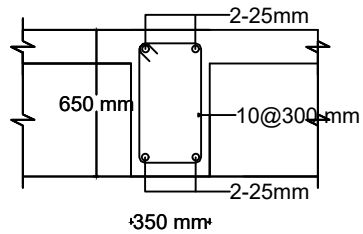

Section at B-B

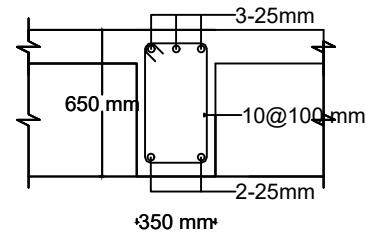

Section at C-C

FIFTH FLOOR BEAM BC - 4th GRID

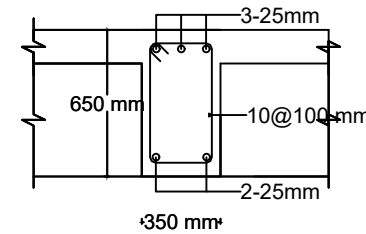

Section at A-A

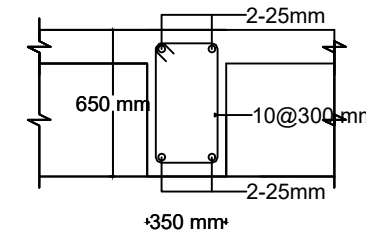

Section at B-B

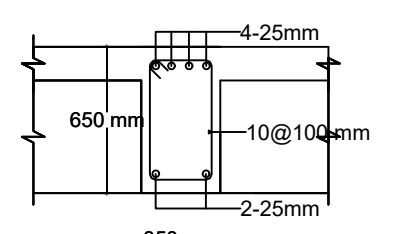

Section at C-C

FIFTH FLOOR BEAM DE - 4th GRID

INSTITUTE OF ENGINEERING PULCHOWK CAMPUS PULCHOWK, LALITPUR	PROJECT TITLE	SHEET TITLE	SUBMITTED TO:	SUBMITTED BY:		SCALE: FIT TO SCALE
	EARTHQUAKE RESISTANT ANALYSIS AND DESIGN OF MULTIPURPOSE BUILDING	FIFTH FLOOR BEAM SECTIONS OF BUILDING 2	DEPARTMENT OF CIVIL ENGINEERING PULCHOWK CAMPUS	Prakrit Devkota (PUL075BCE101)	Priyanshu Pokhrel (PUL075BCE109)	SHEET NO. 43
				Ram Krishna Kandel (PUL075BCE116)	Rijab Ali Miya (PUL075BCE119)	
				Safal Katwal (PUL075BCE129)	Sangam Poudel (PUL075BCE142)	SUBMISSION DATE: April 2023
			PROJECT SUPERVISOR:	Asst. Prof. Aakarsha Khawas		

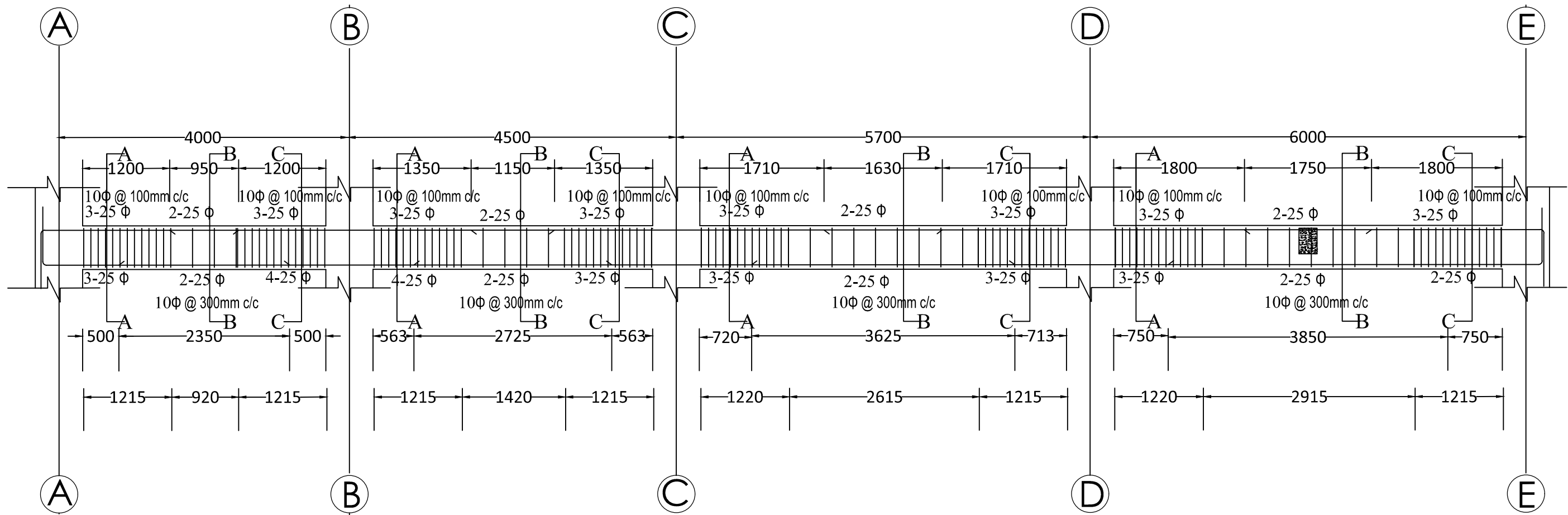

REINFORCEMENT DETAILING GRID 4 6TH FLOOR

INSTITUTE OF ENGINEERING PULCHOWK CAMPUS PULCHOWK, LALITPUR	PROJECT TITLE	SHEET TITLE	SUBMITTED TO:	SUBMITTED BY:		SCALE: FIT TO SCALE
	EARTHQUAKE RESISTANT ANALYSIS AND DESIGN OF MULTIPURPOSE BUILDING	SIXTH FLOOR BEAM DETAILING OF BUILDING 2	DEPARTMENT OF CIVIL ENGINEERING PULCHOWK CAMPUS	Prakrit Devkota (PUL075BCE101)	Priyanshu Pokhrel (PUL075BCE109)	SHEET NO. 44
				Ram Krishna Kandel (PUL075BCE116)	Rijab Ali Miya (PUL075BCE119)	SUBMISSION DATE:
				Safal Katwal (PUL075BCE129)	Sangam Poudel (PUL075BCE142)	April 2023
			PROJECT SUPERVISOR:	Asst. Prof. Aakarsha Khawas		

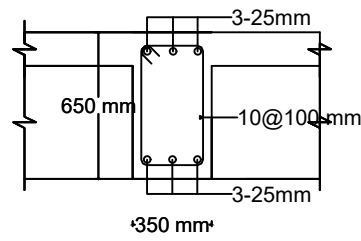

Section at A-A

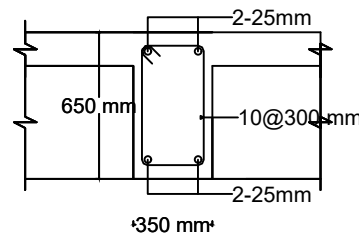

Section at B-B

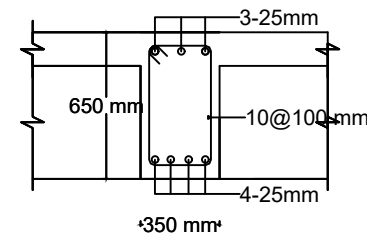

Section at C-C

SIXTH FLOOR BEAM AB - 4th GRID

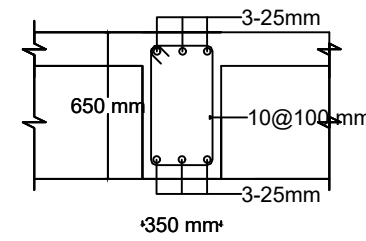

Section at A-A

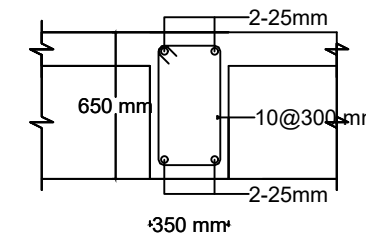

Section at B-B

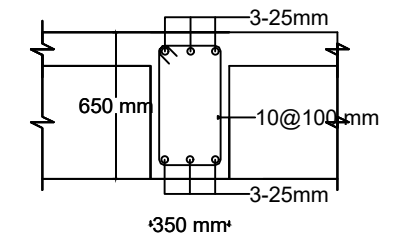

Section at C-C

SIXTH FLOOR BEAM CD - 4th GRID

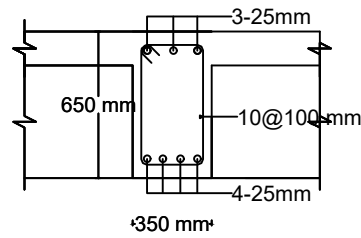

Section at A-A

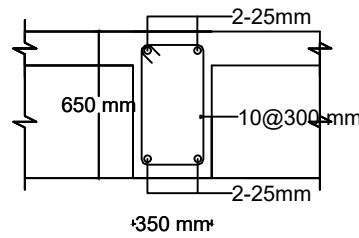

Section at B-B

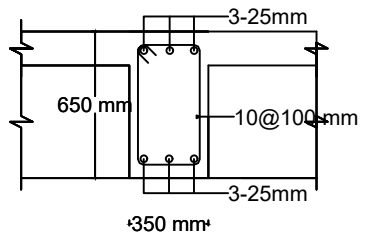

Section at C-C

SIXTH FLOOR BEAM BC - 4th GRID

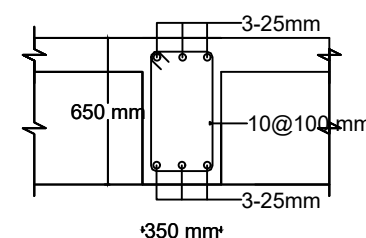

Section at A-A

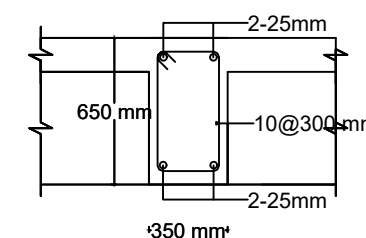

Section at B-B

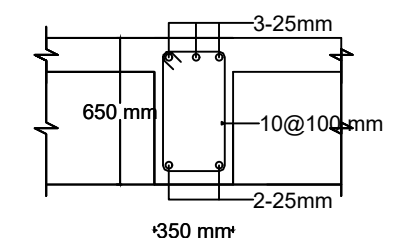

Section at C-C

SIXTH FLOOR BEAM DE - 4th GRID

INSTITUTE OF ENGINEERING PULCHOWK CAMPUS PULCHOWK, LALITPUR	PROJECT TITLE	SHEET TITLE	SUBMITTED TO:	SUBMITTED BY:		SCALE: FIT TO SCALE
	EARTHQUAKE RESISTANT ANALYSIS AND DESIGN OF MULTIPURPOSE BUILDING	SIXTH FLOOR BEAM SECTIONS OF BUILDING 2	DEPARTMENT OF CIVIL ENGINEERING PULCHOWK CAMPUS	Prakrit Devkota (PUL075BCE101)	Priyanshu Pokhrel (PUL075BCE109)	SHEET NO. 45
				Ram Krishna Kandel (PUL075BCE116)	Rijab Ali Miya (PUL075BCE119)	
				Safal Katwal (PUL075BCE129)	Sangam Poudel (PUL075BCE142)	SUBMISSION DATE: April 2023
			PROJECT SUPERVISOR:	Asst. Prof. Aakarsha Khawas		

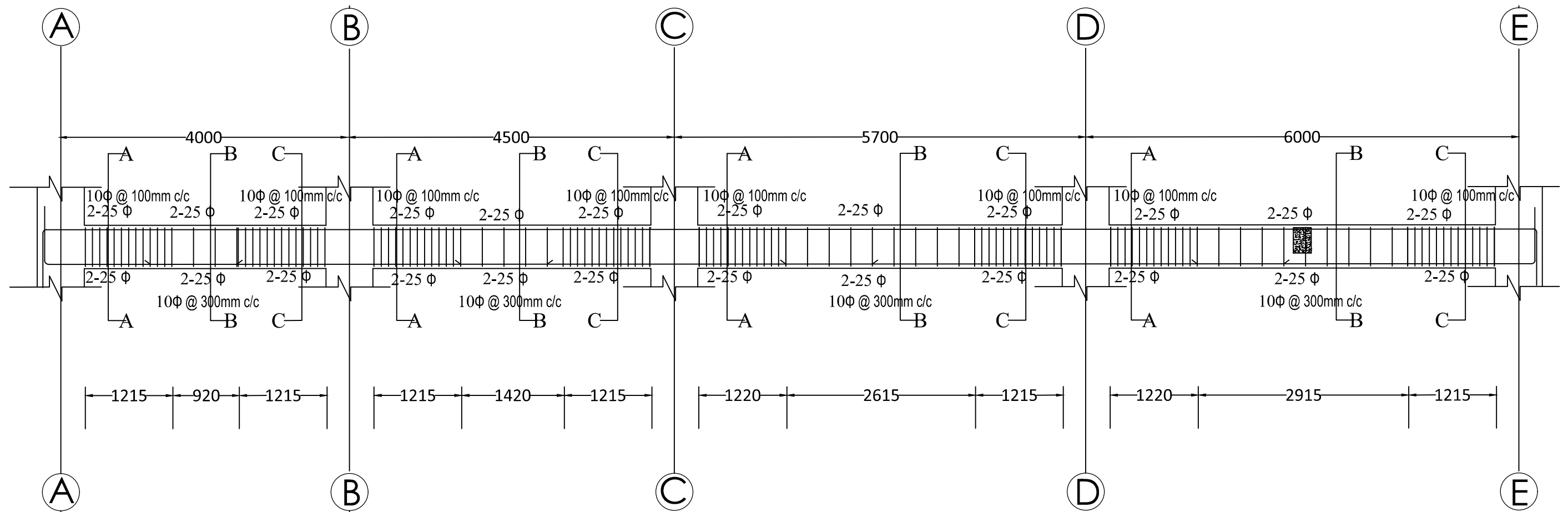

REINFORCEMENT DETAILING GRID 4 TOP FLOOR

INSTITUTE OF ENGINEERING PULCHOWK CAMPUS PULCHOWK, LALITPUR	PROJECT TITLE	SHEET TITLE	SUBMITTED TO:	SUBMITTED BY:		SCALE: FIT TO SCALE
	EARTHQUAKE RESISTANT ANALYSIS AND DESIGN OF MULTIPURPOSE BUILDING	TOP FLOOR BEAM DETAILING OF BUILDING 2	DEPARTMENT OF CIVIL ENGINEERING PULCHOWK CAMPUS	Prakrit Devkota (PUL075BCE101)	Priyanshu Pokhrel (PUL075BCE109)	SHEET NO. 46
				Ram Krishna Kandel (PUL075BCE116)	Rijab Ali Miya (PUL075BCE119)	
				Safal Katwal (PUL075BCE129)	Sangam Poudel (PUL075BCE142)	SUBMISSION DATE: April 2023
			PROJECT SUPERVISOR:	Asst. Prof. Aakarsha Khawas		

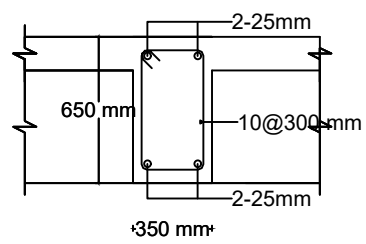

Section at A-A

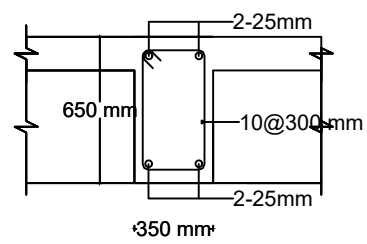

Section at B-B

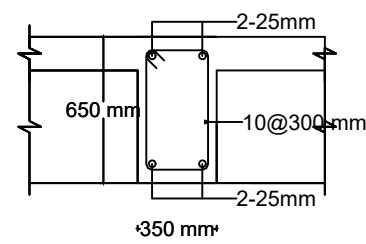

Section at C-C

TOP FLOOR BEAM AB - 4th GRID

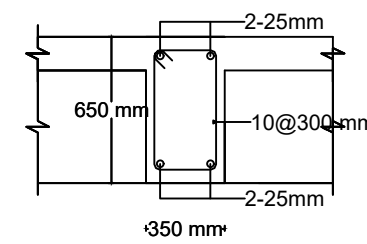

Section at A-A

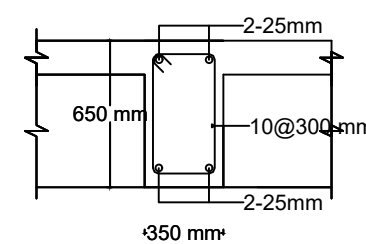

Section at B-B

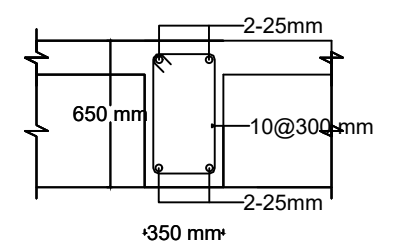

Section at C-C

TOP FLOOR BEAM CD - 4th GRID

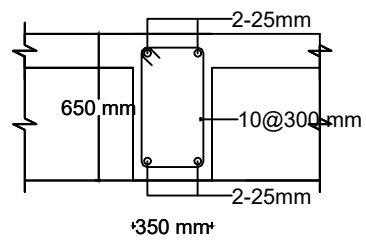

Section at A-A

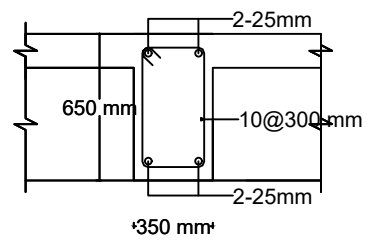

Section at B-B

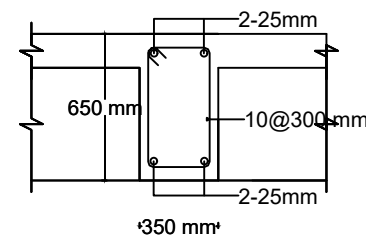

Section at C-C

TOP FLOOR BEAM BC - 4th GRID

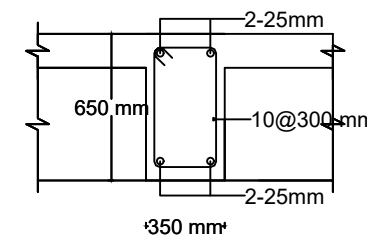

Section at A-A

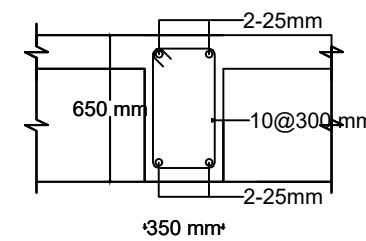

Section at B-B

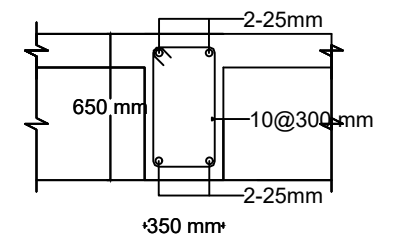

Section at C-C

TOP FLOOR BEAM DE- 4th GRID

INSTITUTE OF ENGINEERING PULCHOWK CAMPUS PULCHOWK, LALITPUR	PROJECT TITLE	SHEET TITLE	SUBMITTED TO:	SUBMITTED BY:		SCALE: FIT TO SCALE
	EARTHQUAKE RESISTANT ANALYSIS AND DESIGN OF MULTIPURPOSE BUILDING	TOP FLOOR BEAM SECTIONS OF BUILDING 2	DEPARTMENT OF CIVIL ENGINEERING PULCHOWK CAMPUS	Prakrit Devkota (PUL075BCE101)	Priyanshu Pokhrel (PUL075BCE109)	SHEET NO. 47
				Ram Krishna Kandel (PUL075BCE116)	Rijab Ali Miya (PUL075BCE119)	
				Safal Katwal (PUL075BCE129)	Sangam Poudel (PUL075BCE142)	SUBMISSION DATE: April 2023
			PROJECT SUPERVISOR:	Asst. Prof. Aakarsha Khawas		

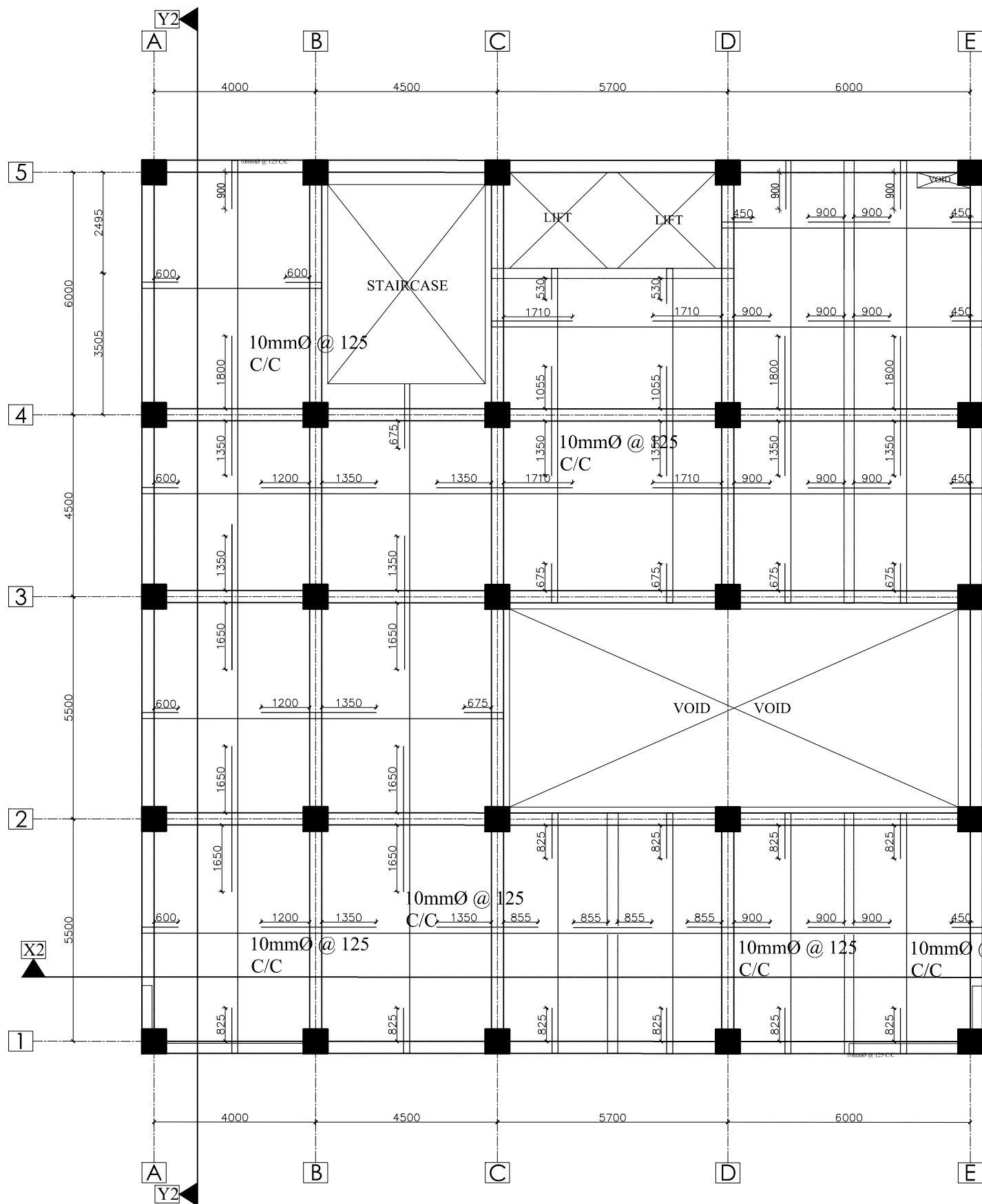

SECOND TO SIXTH FLOOR SLAB LAYOUT PLAN (BUILDING 2ND)

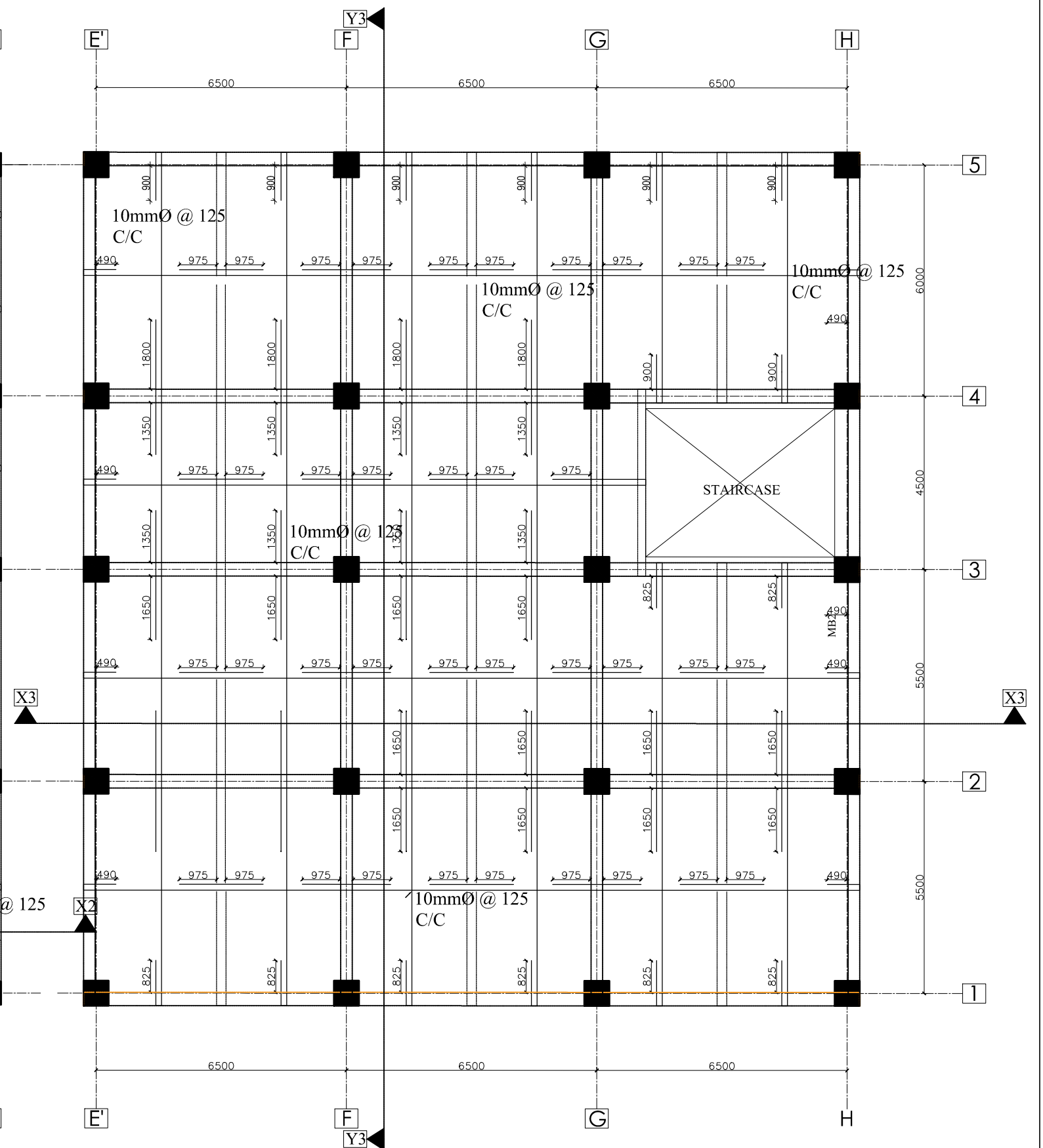

SECOND TO SIXTH FLOOR SLAB LAYOUT PLAN (BUILDING 1ST)

INSTITUTE OF ENGINEERING PULCHOWK CAMPUS PULCHOWK, LALITPUR	PROJECT TITLE	SHEET TITLE	SUBMITTED TO:	SUBMITTED BY:		SCALE: FIT TO SCALE
	EARTHQUAKE RESISTANT ANALYSIS AND DESIGN OF MULTIPURPOSE BUILDING	SLAB LAYOUT	DEPARTMENT OF CIVIL ENGINEERING PULCHOWK CAMPUS	Prakrit Devkota (PUL075BCE101)	Priyanshu Pokhrel (PUL075BCE109)	SHEET NO. 48
				Ram Krishna Kandel (PUL075BCE116)	Rijab Ali Miya (PUL075BCE119)	SUBMISSION DATE:
				Safal Katwal (PUL075BCE129)	Sangam Poudel (PUL075BCE142)	April 2023
			PROJECT SUPERVISOR:	Asst. Prof. Aakarsha Khawas		

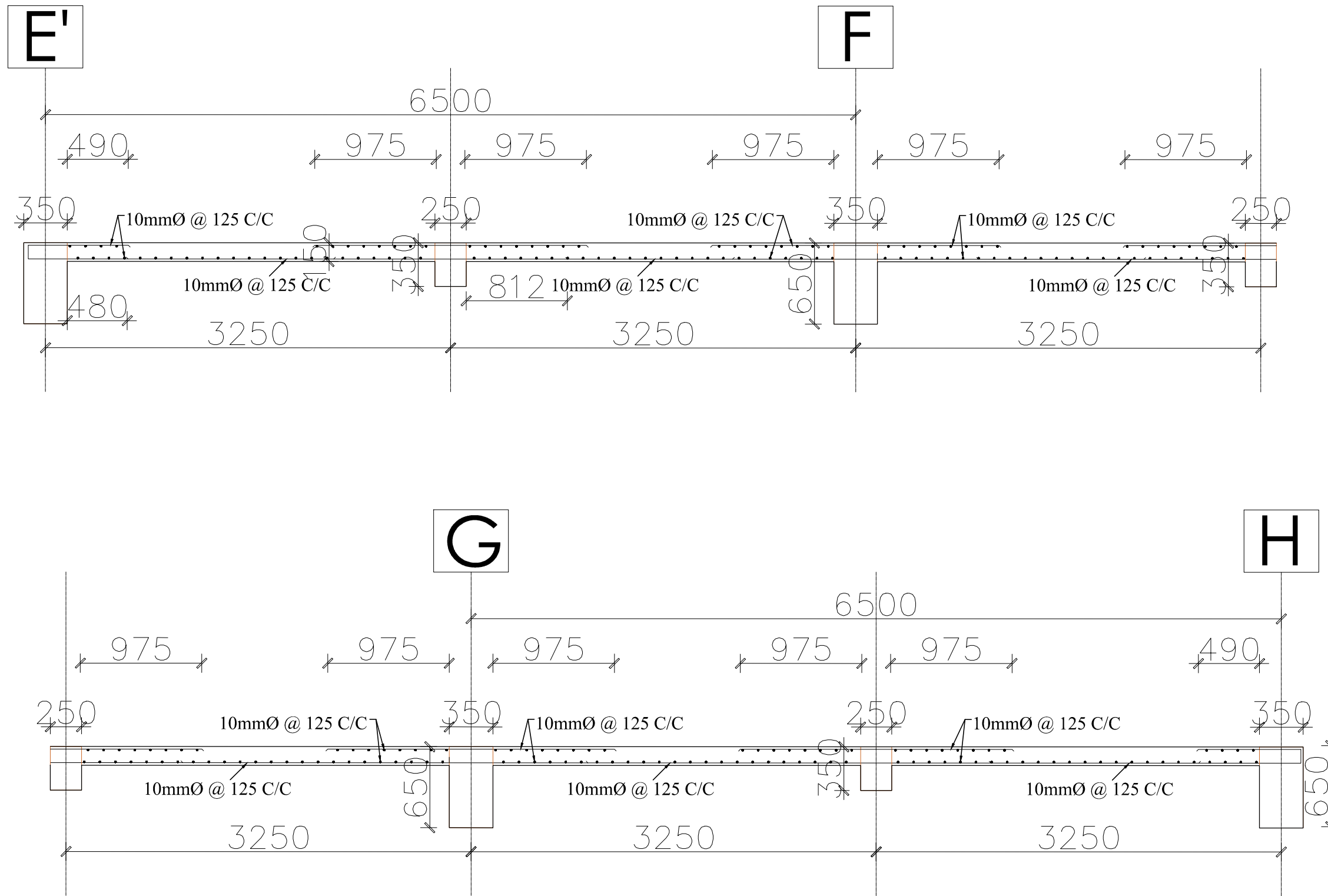

TYPICAL SLAB SECTION AT X3-X3 DIRECTION

ALL REINFORCEMENT ARE OF 10mmØ- @ 125mm c/c ON BOTH DIRECTIONS
SLAB: 150 MM THICK

INSTITUTE OF ENGINEERING PULCHOWK CAMPUS PULCHOWK, LALITPUR	PROJECT TITLE	SHEET TITLE	SUBMITTED TO:	SUBMITTED BY:		SCALE: FIT TO SCALE
	EARTHQUAKE RESISTANT ANALYSIS AND DESIGN OF MULTIPURPOSE BUILDING	SLAB SECTIONS OF BUILDING 1	DEPARTMENT OF CIVIL ENGINEERING PULCHOWK CAMPUS	Prakrit Devkota (PUL075BCE101)	Priyanshu Pokhrel (PUL075BCE109)	SHEET NO. 49
				Ram Krishna Kandel (PUL075BCE116)	Rijab Ali Miya (PUL075BCE119)	
				Safal Katwal (PUL075BCE129)	Sangam Poudel (PUL075BCE142)	SUBMISSION DATE: April 2023
			PROJECT SUPERVISOR:	Asst. Prof. Aakarsha Khawas		

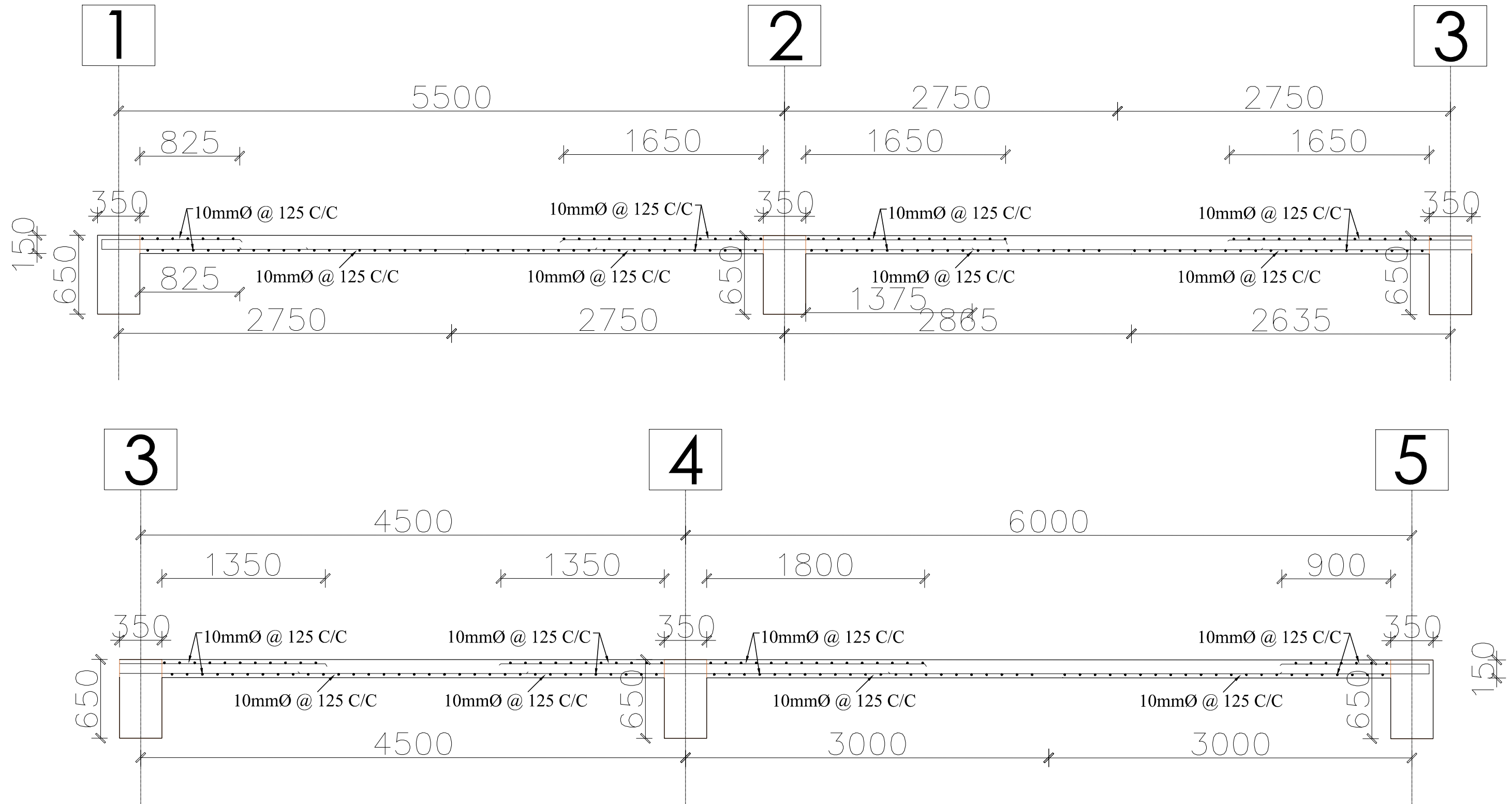

TYPICAL SLAB SECTION AT Y3-Y3 DIRECTION

ALL REINFORCEMENT ARE OF 10mmØ- @ 125mm c/c ON BOTH DIRECTIONS SLAB: 150 MM THICK

INSTITUTE OF ENGINEERING PULCHOWK CAMPUS PULCHOWK, LALITPUR	PROJECT TITLE	SHEET TITLE	SUBMITTED TO:	SUBMITTED BY:		SCALE: FIT TO SCALE
	EARTHQUAKE RESISTANT ANALYSIS AND DESIGN OF MULTIPURPOSE BUILDING	SLAB SECTIONS OF BUILDING 1	DEPARTMENT OF CIVIL ENGINEERING PULCHOWK CAMPUS	Prakrit Devkota (PUL075BCE101)	Priyanshu Pokhrel (PUL075BCE109)	SHEET NO. 50
				Ram Krishna Kandel (PUL075BCE116)	Rijab Ali Miya (PUL075BCE119)	
				Safal Katwal (PUL075BCE129)	Sangam Poudel (PUL075BCE142)	SUBMISSION DATE: April 2023
			PROJECT SUPERVISOR:	Asst. Prof. Aakarsha Khawas		

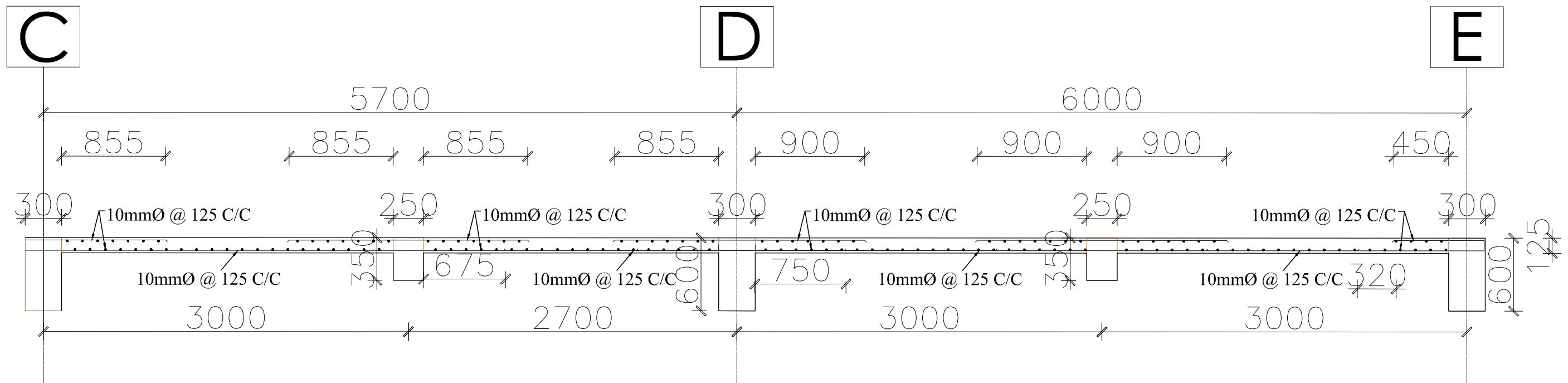
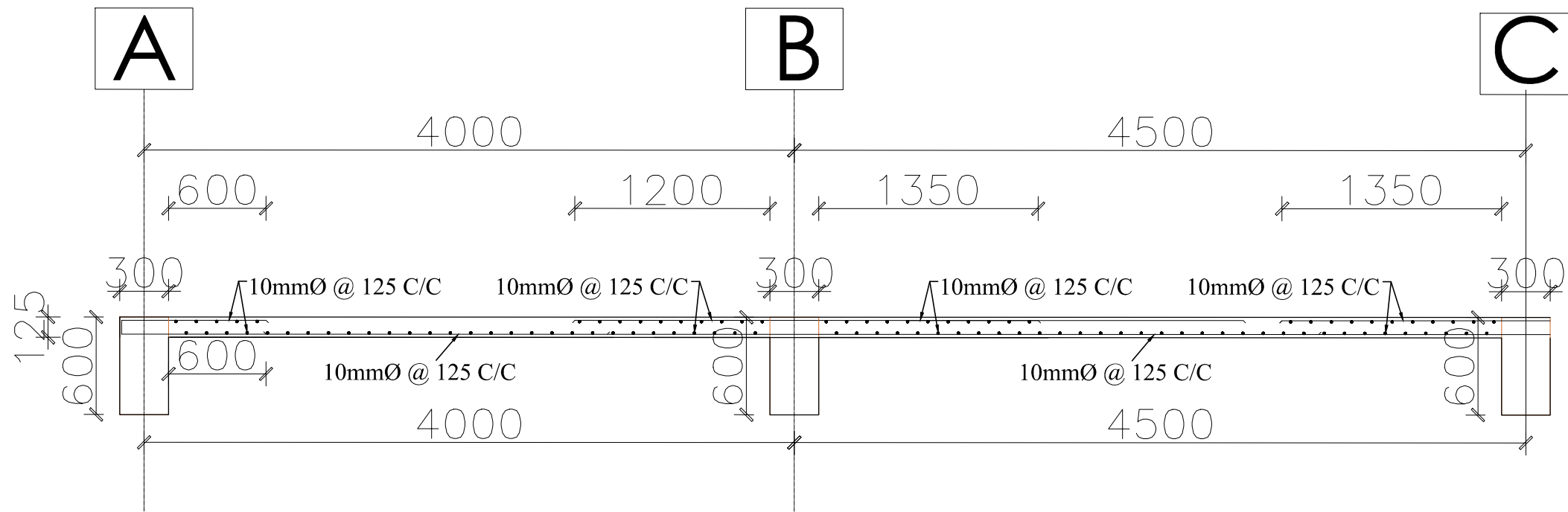

SLAB SECTION AT X2-X2 DIRECTION

ALL REINFORCEMENT ARE OF 10mmØ- @ 125mm c/c ON BOTH DIRECTIONS MAIN SLAB: 125 MM THICK

INSTITUTE OF ENGINEERING PULCHOWK CAMPUS PULCHOWK, LALITPUR	PROJECT TITLE	SHEET TITLE	SUBMITTED TO:	SUBMITTED BY:		SCALE: FIT TO SCALE
	EARTHQUAKE RESISTANT ANALYSIS AND DESIGN OF MULTIPURPOSE BUILDING	SLAB SECTIONS OF BUILDING 2	DEPARTMENT OF CIVIL ENGINEERING PULCHOWK CAMPUS	Prakrit Devkota (PUL075BCE101)	Priyanshu Pokhrel (PUL075BCE109)	SHEET NO. 51
				Ram Krishna Kandel (PUL075BCE116)	Rijab Ali Miya (PUL075BCE119)	
				Safal Katwal (PUL075BCE129)	Sangam Poudel (PUL075BCE142)	SUBMISSION DATE: April 2023
			PROJECT SUPERVISOR:	Asst. Prof. Aakarsha Khawas		

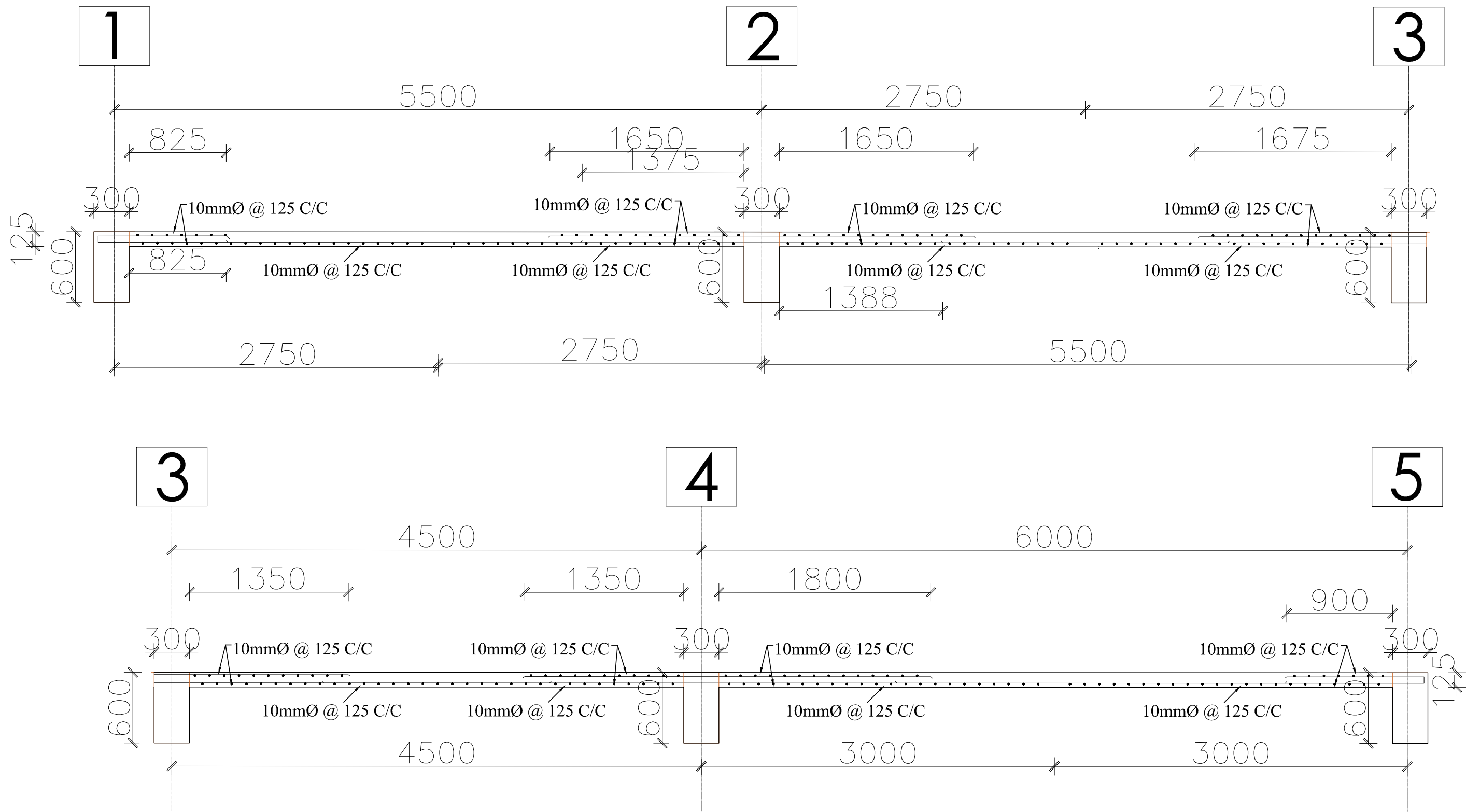

TYPICAL SLAB SECTION AT Y2-Y2 DIRECTION

ALL REINFORCEMENT ARE OF 10mmØ- @ 125mm c/c ON BOTH DIRECTION SLAB: 125 MM THICK

INSTITUTE OF ENGINEERING PULCHOWK CAMPUS PULCHOWK, LALITPUR	PROJECT TITLE	SHEET TITLE	SUBMITTED TO:	SUBMITTED BY:		SCALE: FIT TO SCALE
	EARTHQUAKE RESISTANT ANALYSIS AND DESIGN OF MULTIPURPOSE BUILDING	SLAB SECTIONS OF BUILDING 2	DEPARTMENT OF CIVIL ENGINEERING PULCHOWK CAMPUS	Prakrit Devkota (PUL075BCE101)	Priyanshu Pokhrel (PUL075BCE109)	SHEET NO. 52
				Ram Krishna Kandel (PUL075BCE116)	Rijab Ali Miya (PUL075BCE119)	
				Safal Katwal (PUL075BCE129)	Sangam Poudel (PUL075BCE142)	SUBMISSION DATE:
				PROJECT SUPERVISOR:	Asst. Prof. Aakarsha Khawas	April 2023

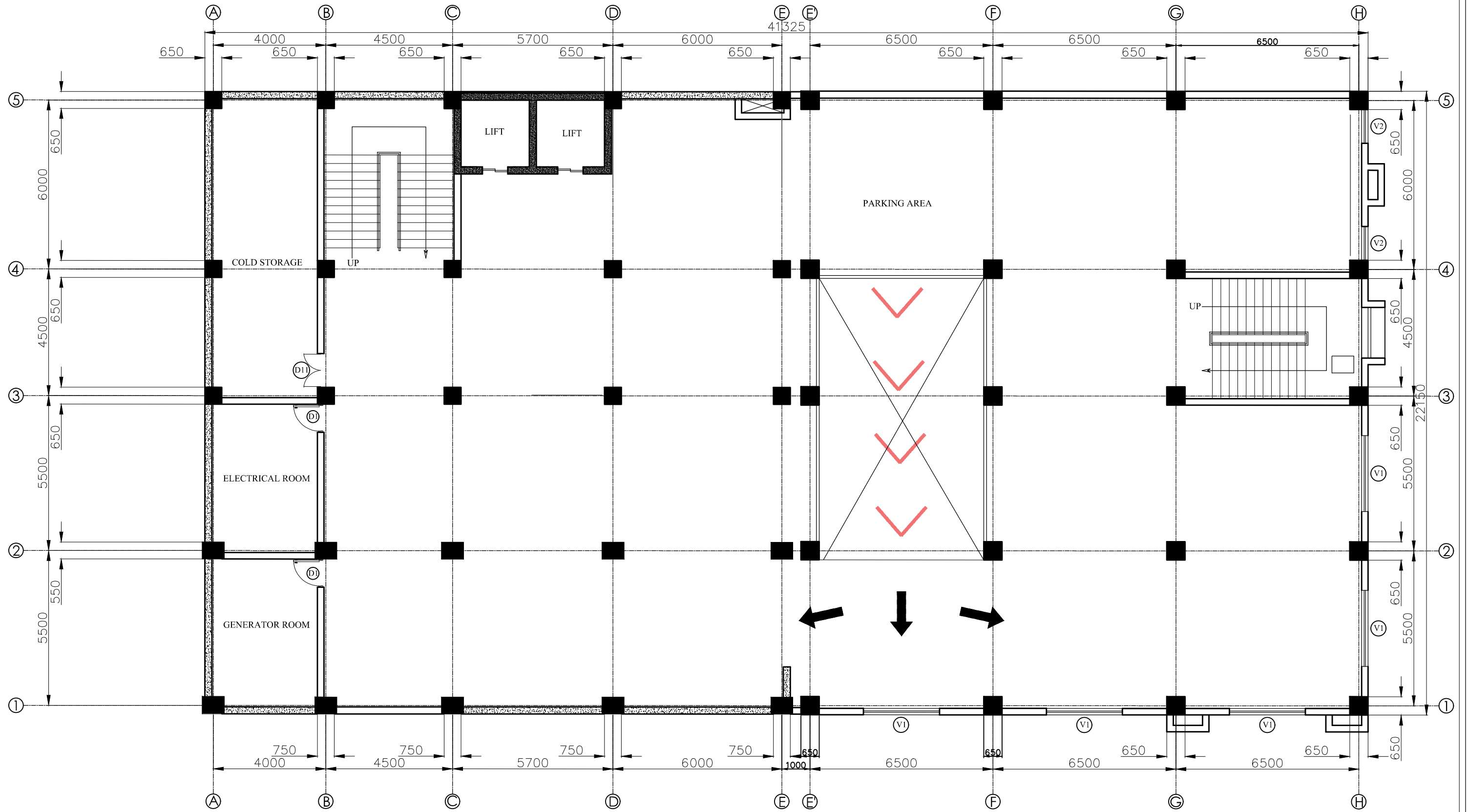

COLUMN LAYOUT

INSTITUTE OF ENGINEERING PULCHOWK CAMPUS PULCHOWK, LALITPUR	PROJECT TITLE	SHEET TITLE	SUBMITTED TO:	SUBMITTED BY:		SCALE: FIT TO SCALE
	EARTHQUAKE RESISTANT ANALYSIS AND DESIGN OF MULTIPURPOSE BUILDING	Column Layout	DEPARTMENT OF CIVIL ENGINEERING PULCHOWK CAMPUS	Prakrit Devkota (PUL075BCE101)	Priyanshu Pokhrel (PUL075BCE109)	SHEET NO. 53
				Ram Krishna Kandel (PUL075BCE116)	Rijab Ali Miya (PUL075BCE119)	SUBMISSION DATE:
				Safal Katwal (PUL075BCE129)	Sangam Poudel (PUL075BCE142)	April 2023
			PROJECT SUPERVISOR:	Asst. Prof. Aakarsha Khawas		

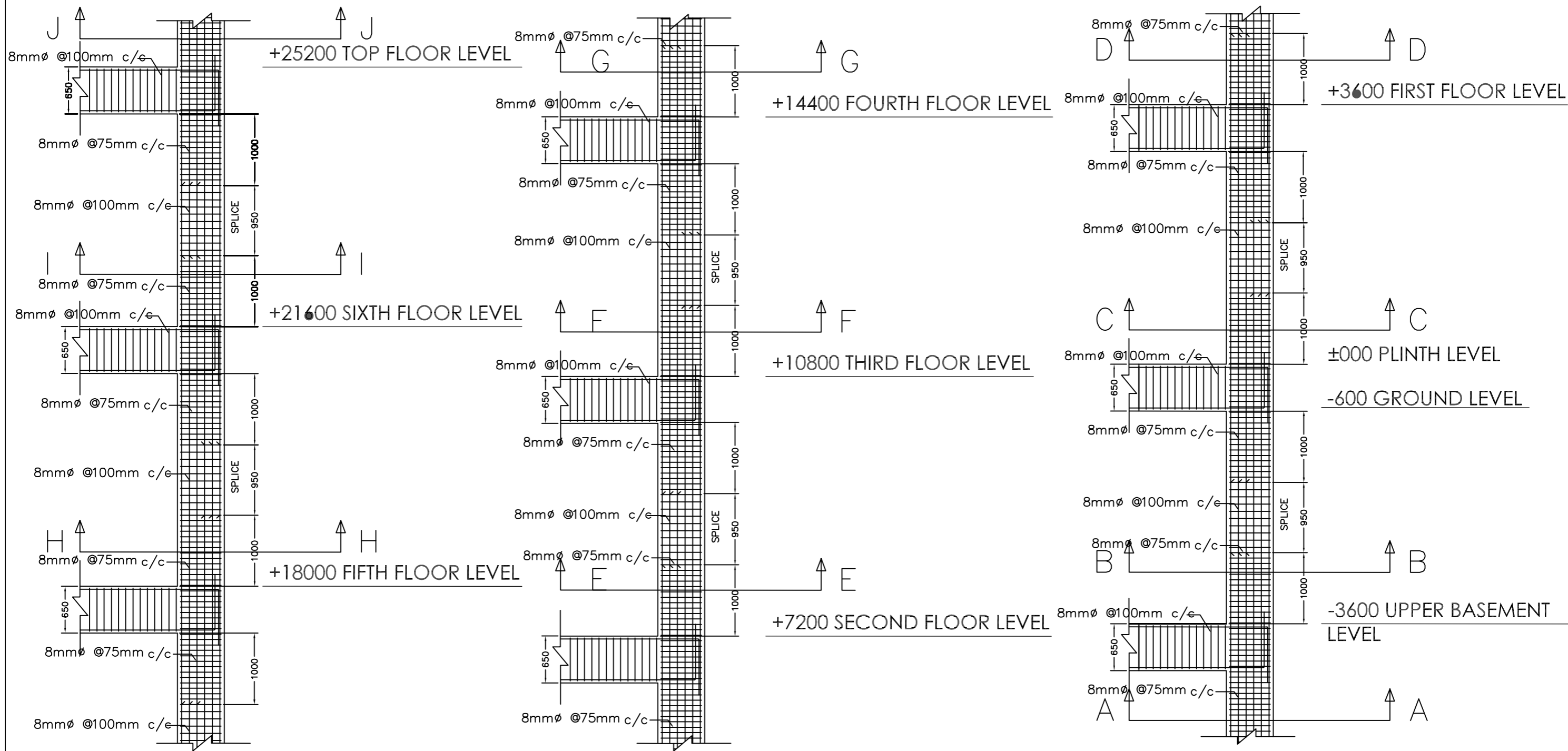

Column Section With special confining detailing C6A

INSTITUTE OF ENGINEERING PULCHOWK CAMPUS PULCHOWK, LALITPUR	PROJECT TITLE	SHEET TITLE	SUBMITTED TO:	SUBMITTED BY:		SCALE: FIT TO SCALE
	EARTHQUAKE RESISTANT ANALYSIS AND DESIGN OF MULTIPURPOSE BUILDING	REINFORCEMENT DETAILING OF COLUMN OF BUILDING 1	DEPARTMENT OF CIVIL ENGINEERING PULCHOWK CAMPUS	Prakrit Devkota (PUL075BCE101)	Priyanshu Pokhrel (PUL075BCE109)	SHEET NO. 54
				Ram Krishna Kandel (PUL075BCE116)	Rijab Ali Miya (PUL075BCE119)	
				Safal Katwal (PUL075BCE129)	Sangam Poudel (PUL075BCE142)	SUBMISSION DATE: April 2023
			PROJECT SUPERVISOR:	Asst. Prof. Aakarsha Khawas		

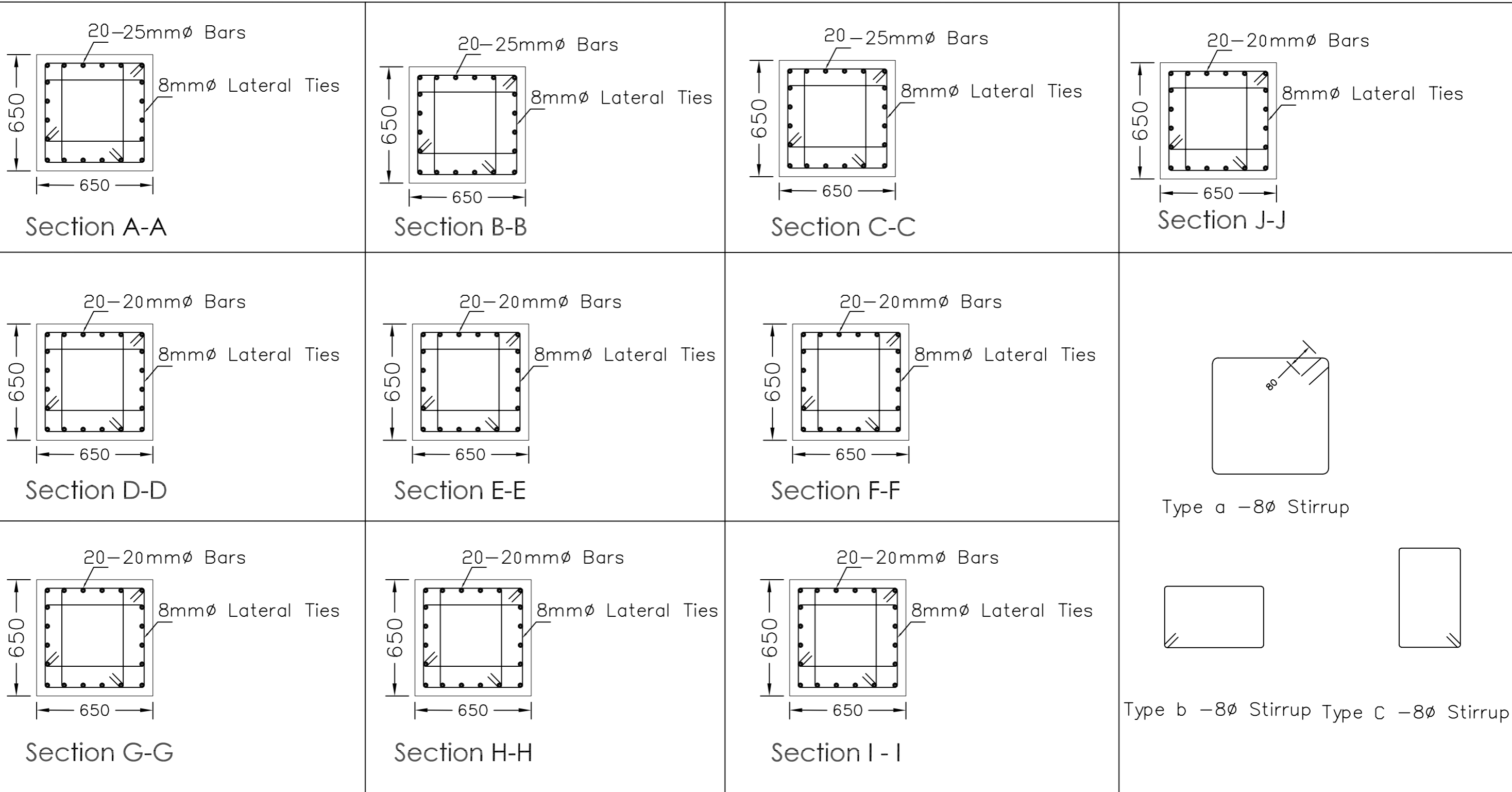

COLUMN REINFORCEMENT DETAILS(650*650)

INSTITUTE OF ENGINEERING PULCHOWK CAMPUS PULCHOWK, LALITPUR	PROJECT TITLE	SHEET TITLE	SUBMITTED TO:	SUBMITTED BY:		SCALE: FIT TO SCALE
	EARTHQUAKE RESISTANT ANALYSIS AND DESIGN OF MULTIPURPOSE BUILDING	COLUMN REINFORCEMENT DETAILS FOR 650 X 650	DEPARTMENT OF CIVIL ENGINEERING PULCHOWK CAMPUS	Prakrit Devkota (PUL075BCE101)	Priyanshu Pokhrel (PUL075BCE109)	SHEET NO. 55
				Ram Krishna Kandel (PUL075BCE116)	Rijab Ali Miya (PUL075BCE119)	SUBMISSION DATE:
				Safal Katwal (PUL075BCE129)	Sangam Poudel (PUL075BCE142)	April 2023
			PROJECT SUPERVISOR:	Asst. Prof. Aakarsha Khawas		

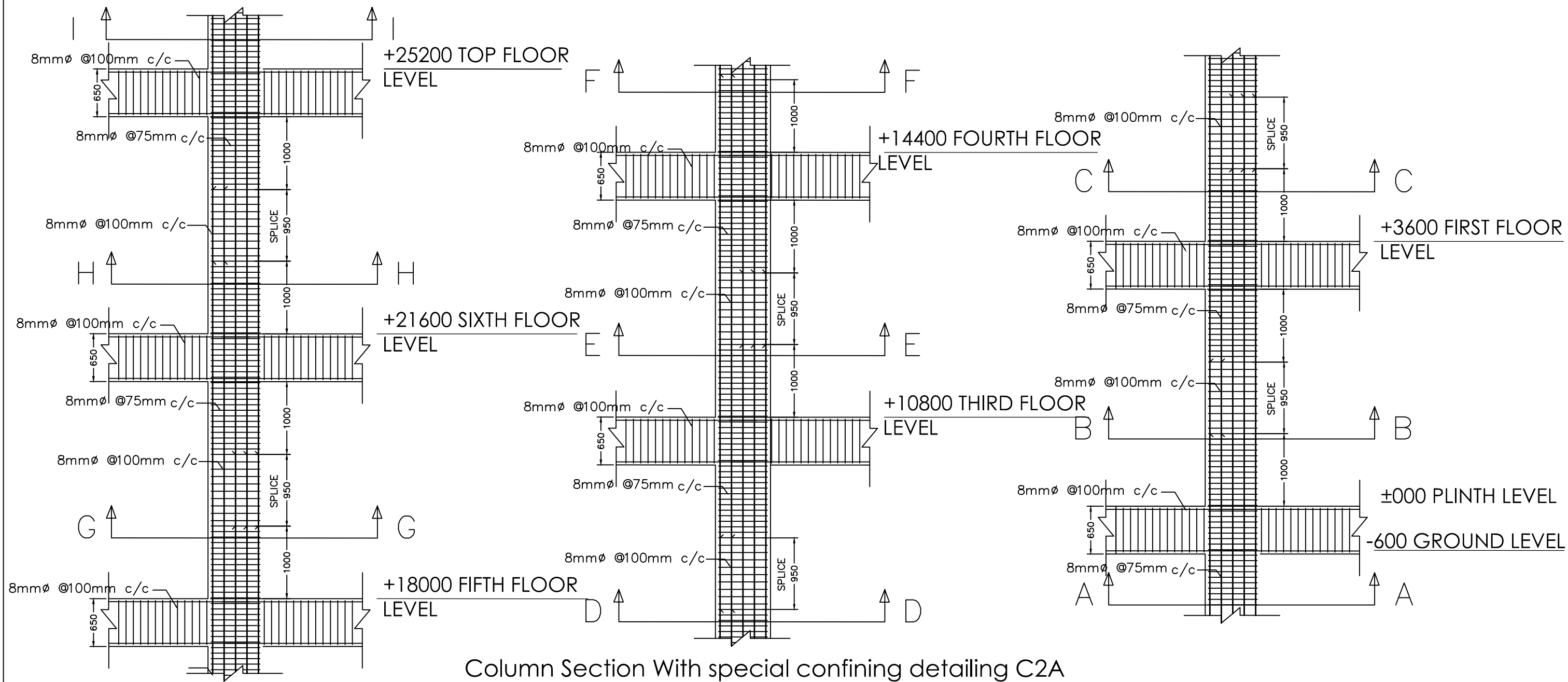

INSTITUTE OF ENGINEERING PULCHOWK CAMPUS PULCHOWK, LALITPUR	PROJECT TITLE	SHEET TITLE	SUBMITTED TO:	SUBMITTED BY:		SCALE: FIT TO SCALE
	EARTHQUAKE RESISTANT ANALYSIS AND DESIGN OF MULTIPURPOSE BUILDING	REINFORCEMENT DETAILS OF COLUMN OF BUILDING 2	DEPARTMENT OF CIVIL ENGINEERING PULCHOWK CAMPUS	Prakrit Devkota (PUL075BCE101)	Priyanshu Pokhrel (PUL075BCE109)	SHEET NO. 56
				Ram Krishna Kandel (PUL075BCE116)	Rijab Ali Miya (PUL075BCE119)	
				Safal Katwal (PUL075BCE129)	Sangam Poudel (PUL075BCE142)	SUBMISSION DATE: April 2023
				PROJECT SUPERVISOR:	Asst. Prof. Aakarsha Khawas	

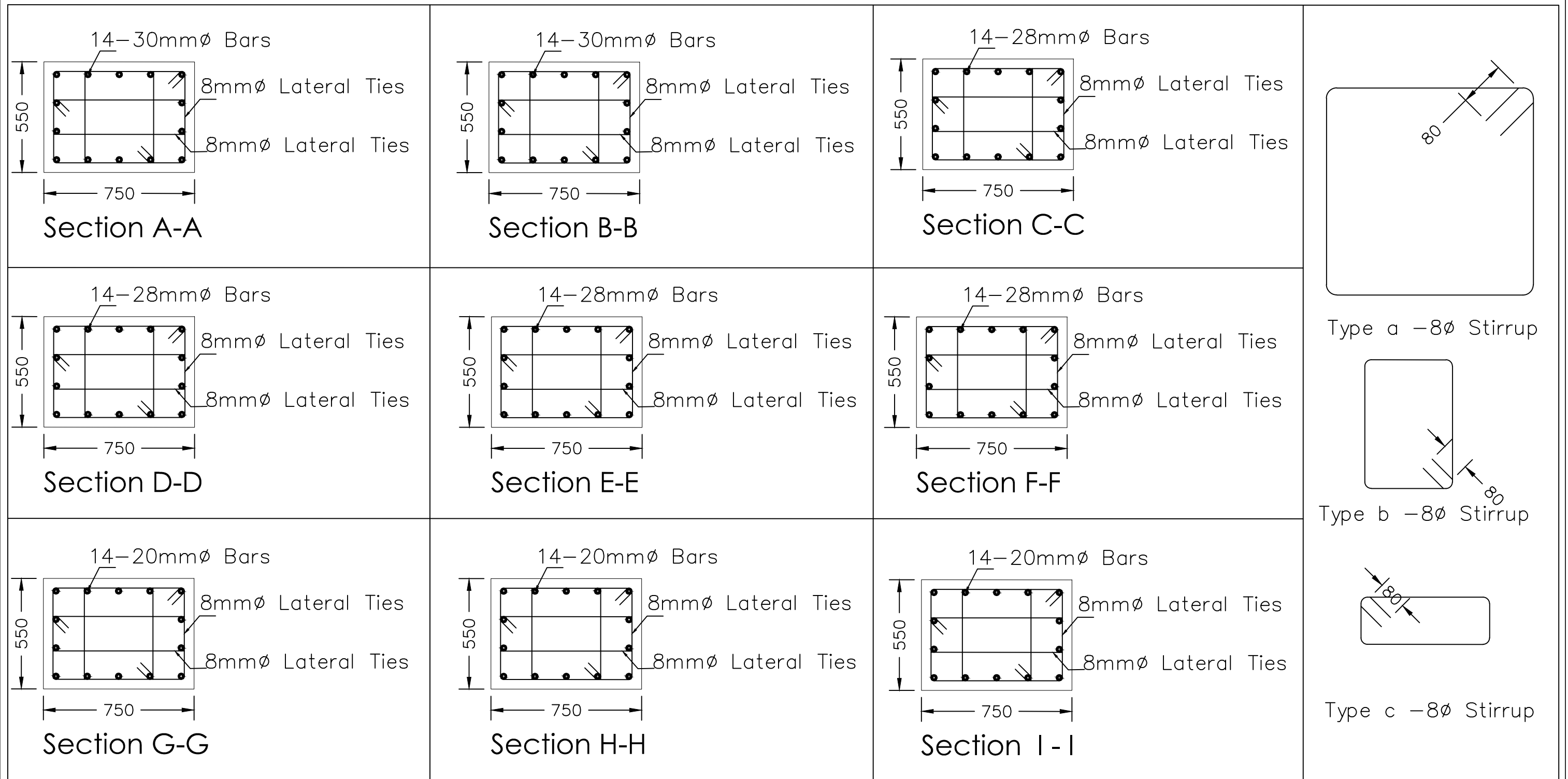

COLUMN REINFORCEMENT DETAILS(750*550)

INSTITUTE OF ENGINEERING PULCHOWK CAMPUS PULCHOWK, LALITPUR	PROJECT TITLE	SHEET TITLE	SUBMITTED TO:	SUBMITTED BY:		SCALE: FIT TO SCALE
	EARTHQUAKE RESISTANT ANALYSIS AND DESIGN OF MULTIPURPOSE BUILDING	COLUMN REINFORCEMENT DETAILS FOR 750 X 550	DEPARTMENT OF CIVIL ENGINEERING PULCHOWK CAMPUS	Prakrit Devkota (PUL075BCE101)	Priyanshu Pokhrel (PUL075BCE109)	SHEET NO. 57
				Ram Krishna Kandel (PUL075BCE116)	Rijab Ali Miya (PUL075BCE119)	SUBMISSION DATE: April 2023
				Safal Katwal (PUL075BCE129)	Sangam Poudel (PUL075BCE142)	
PROJECT SUPERVISOR:				Asst. Prof. Aakarsha Khawas		

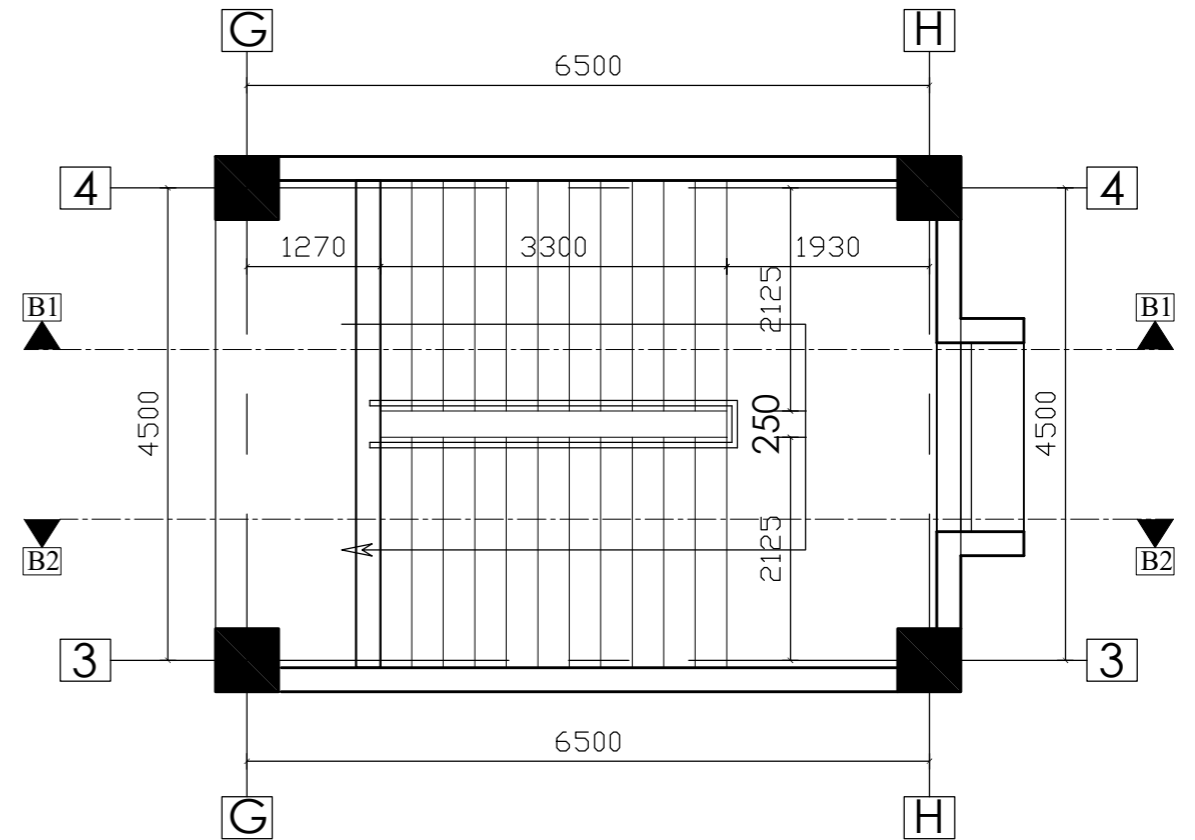
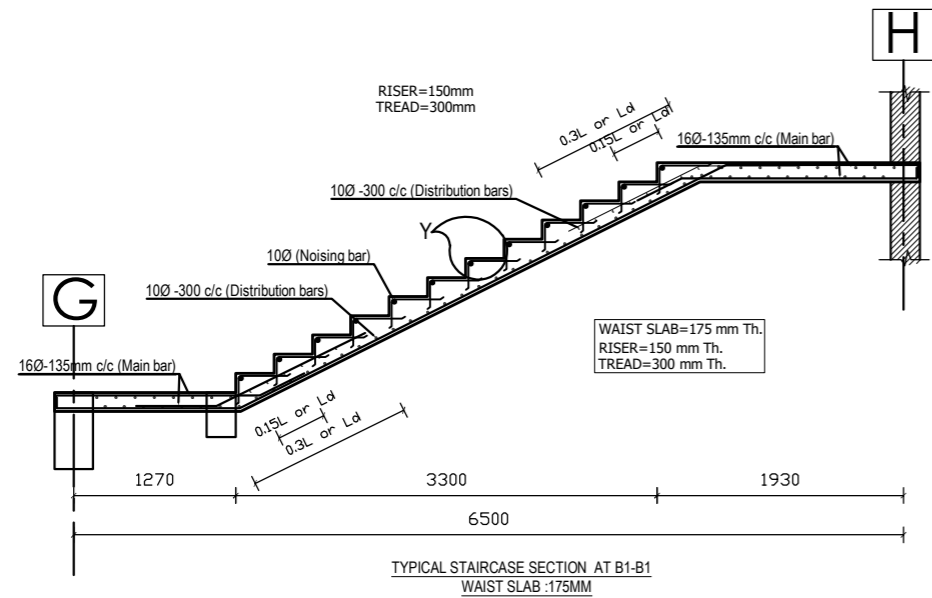
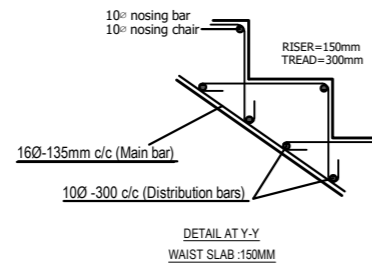

STAIRCASE 1 DETAILS

INSTITUTE OF ENGINEERING PULCHOWK CAMPUS PULCHOWK, LALITPUR	PROJECT TITLE	SHEET TITLE	SUBMITTED TO:	SUBMITTED BY:		SCALE: FIT TO SCALE
	EARTHQUAKE RESISTANT ANALYSIS AND DESIGN OF MULTI-PURPOSE COMMERCIAL BUILDING	REINFORCEMENT DETAILING OF STAIRCASE OF BUILDING 1	DEPARTMENT OF CIVIL ENGINEERING PULCHOWK CAMPUS	Prakrit Devkota (PUL075BCE101)	Priyanshu Pokhrel (PUL075BCE109)	SHEET NO. 58
				Ram Krishna Kandel (PUL075BCE116)	Rijab Ali Miya (PUL075BCE119)	
				Safal Katwal (PUL075BCE129)	Sangam Poudel (PUL075BCE142)	SUBMISSION DATE:
			PROJECT SUPERVISOR:	Asst. Prof. Aakarsha Khawas	28th April, 2023	

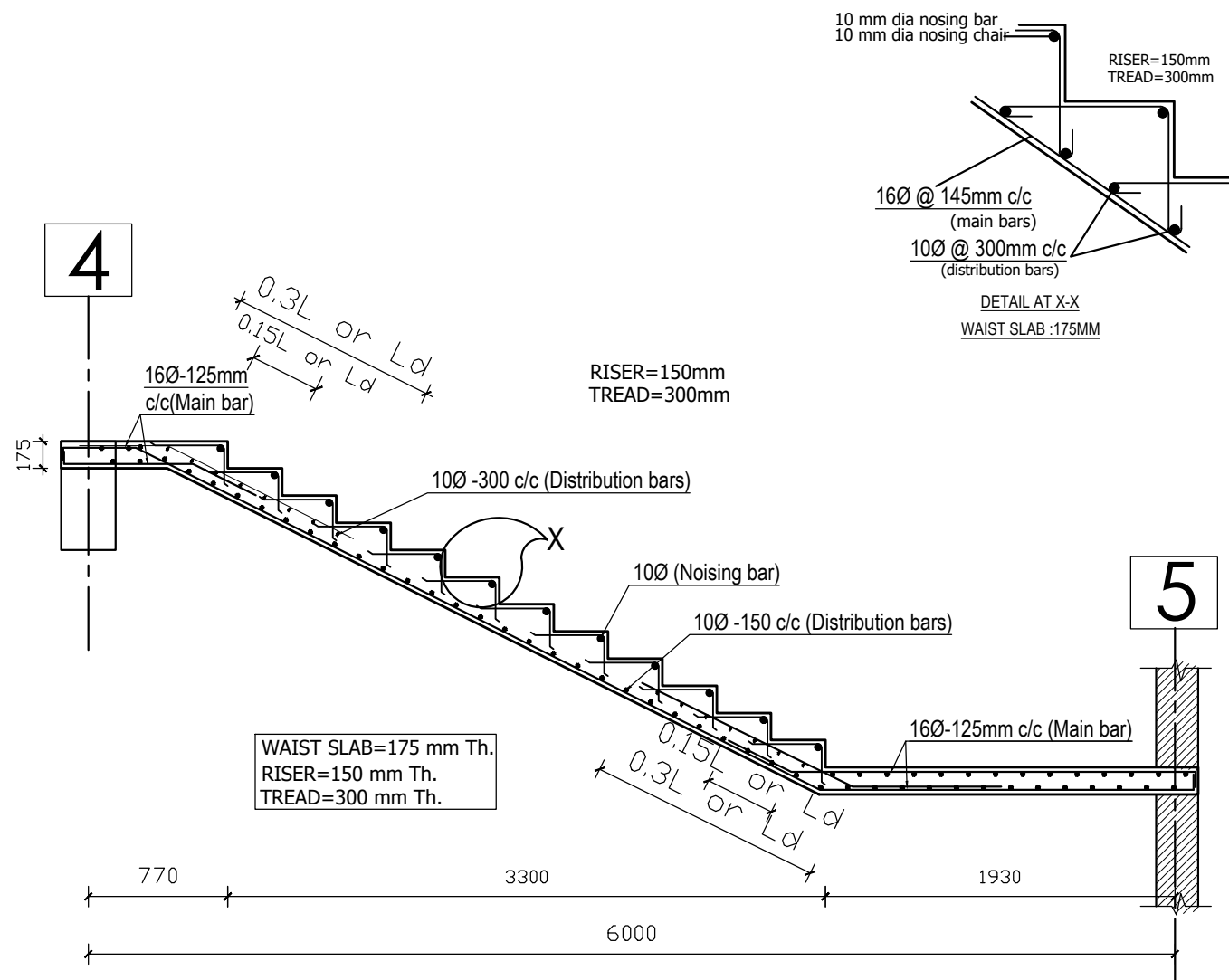

TYPICAL STAIRCASE SECTION AT
A2-A2

WAIST SLAB :175MM

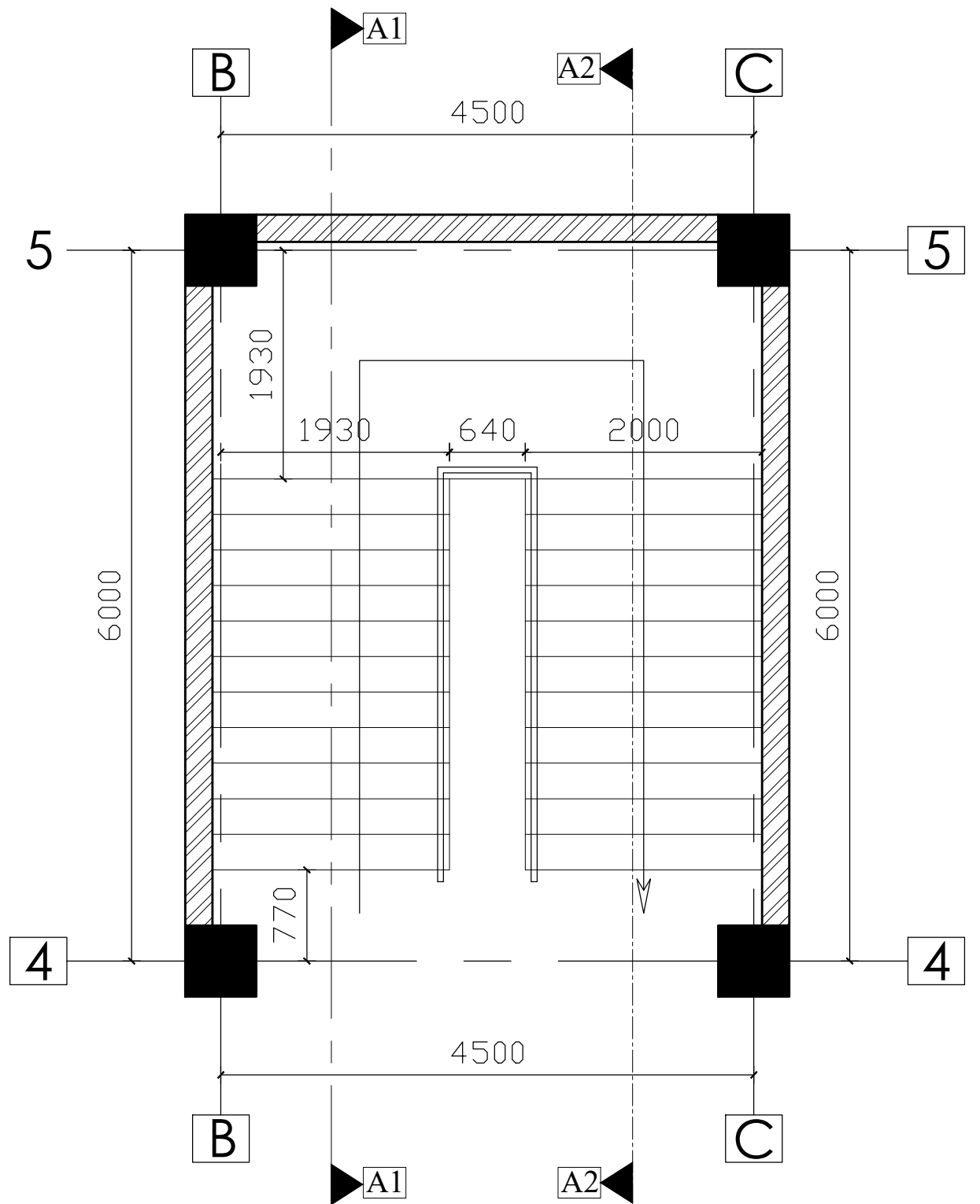

STAIRCASE 2 DETAILS

INSTITUTE OF ENGINEERING PULCHOWK CAMPUS PULCHOWK, LALITPUR	PROJECT TITLE	SHEET TITLE	SUBMITTED TO:	SUBMITTED BY:		SCALE: FIT TO SCALE
	EARTHQUAKE RESISTANT ANALYSIS AND DESIGN OF MULTI-PURPOSE COMMERCIAL BUILDING	REINFORCEMENT DETAILING OF STAIRCASE OF BUILDING 2	DEPARTMENT OF CIVIL ENGINEERING PULCHOWK CAMPUS	Prakrit Devkota (PUL075BCE101)	Priyanshu Pokhrel (PUL075BCE109)	SHEET NO. 59
				Ram Krishna Kandel (PUL075BCE116)	Rijab Ali Miya (PUL075BCE119)	
				Safal Katwal (PUL075BCE129)	Sangam Poudel (PUL075BCE142)	
PROJECT SUPERVISOR:				Asst. Prof. Aakarsha Khawas	SUBMISSION DATE: 28th April, 2023	

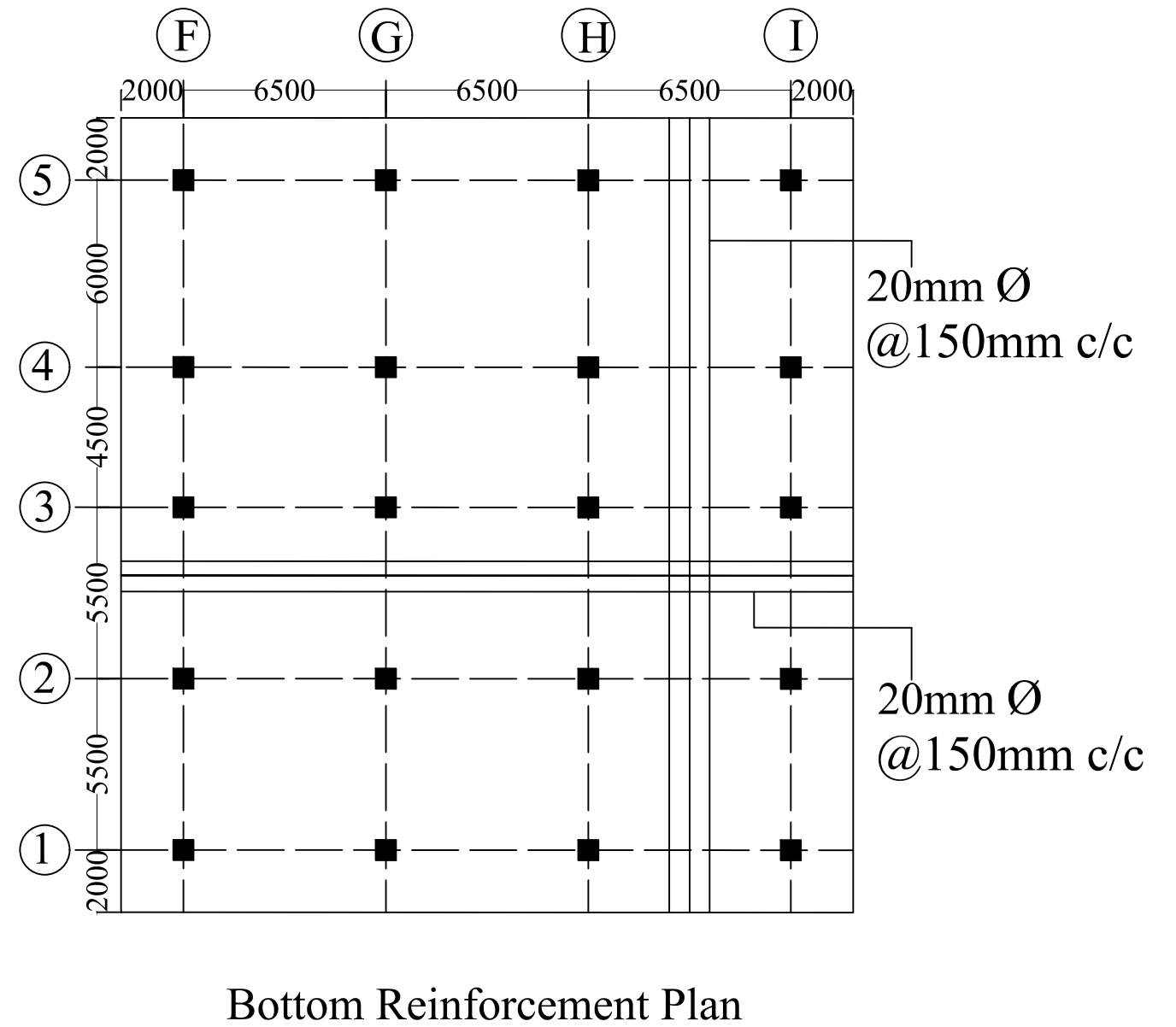
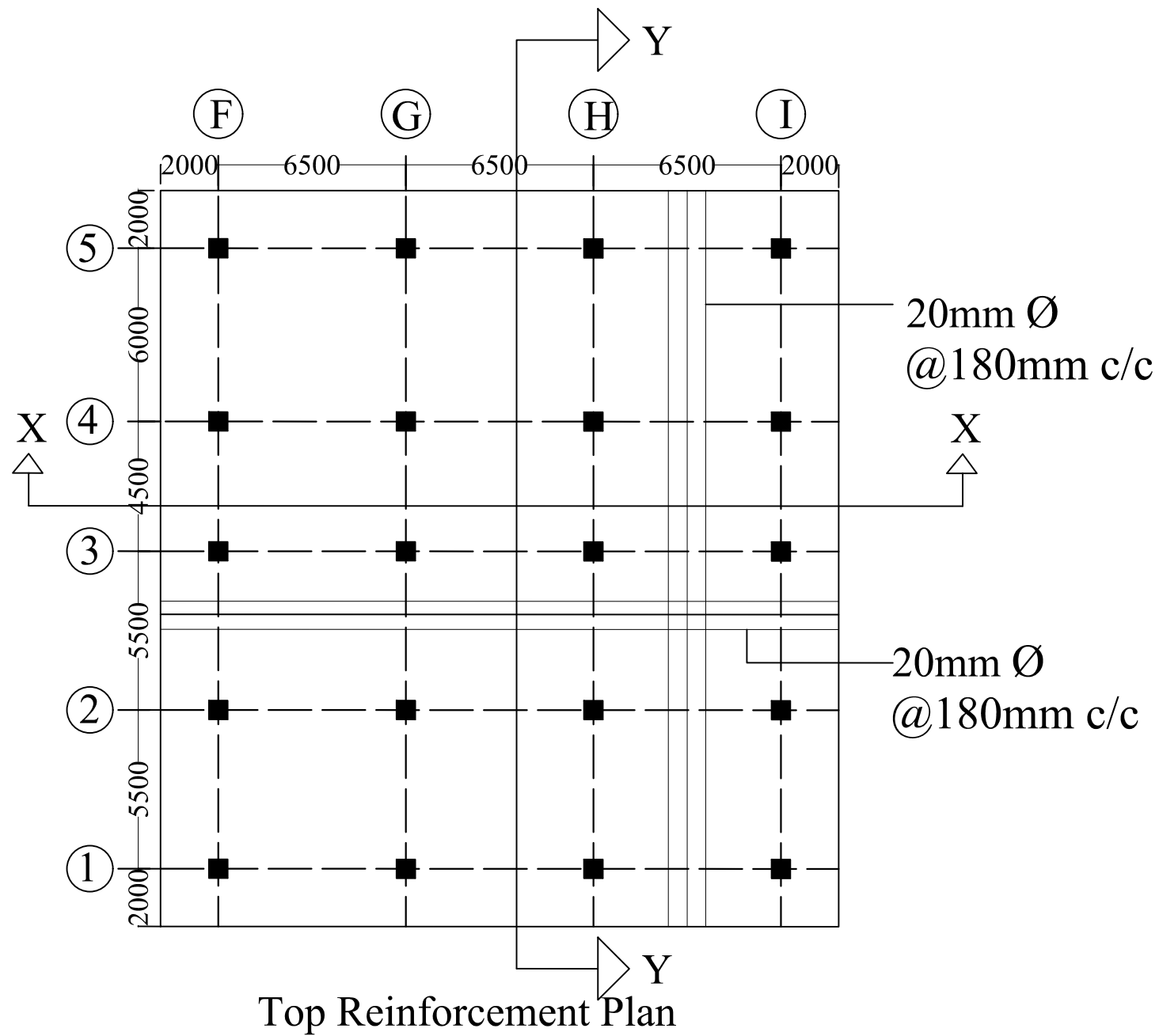

INSTITUTE OF ENGINEERING PULCHOWK CAMPUS PULCHOWK, LALITPUR	PROJECT TITLE	SHEET TITLE	SUBMITTED TO:	SUBMITTED BY:		SCALE: FIT TO SCALE
	EARTHQUAKE RESISTANT ANALYSIS AND DESIGN OF MULTIPURPOSE BUILDING	REINFORCEMENT PLAN OF FOUNDATION OF BUILDING 1	DEPARTMENT OF CIVIL ENGINEERING PULCHOWK CAMPUS	Prakrit Devkota (PUL075BCE101)	Priyanshu Pokhrel (PUL075BCE109)	SHEET NO. 60
				Ram Krishna Kandel (PUL075BCE116)	Rijab Ali Miya (PUL075BCE119)	SUBMISSION DATE: April 2023
				Safal Katwal (PUL075BCE129)	Sangam Poudel (PUL075BCE142)	
PROJECT SUPERVISOR:				Asst. Prof. Aakarsha Khawas		

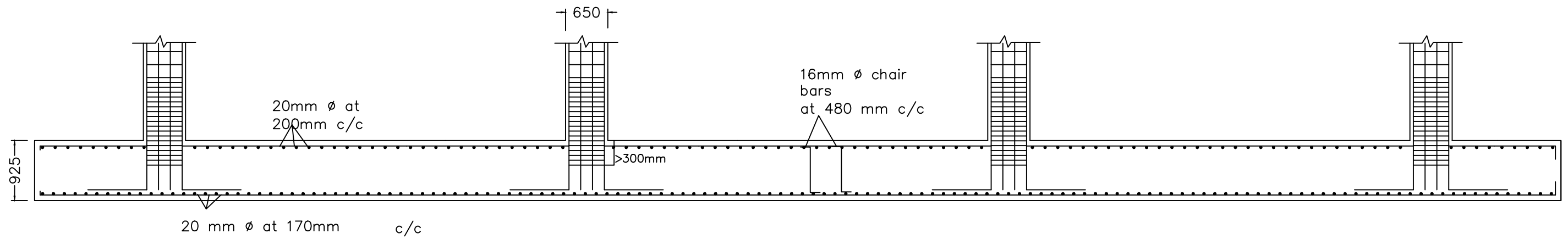

SECTION ALONG X-X AXIS

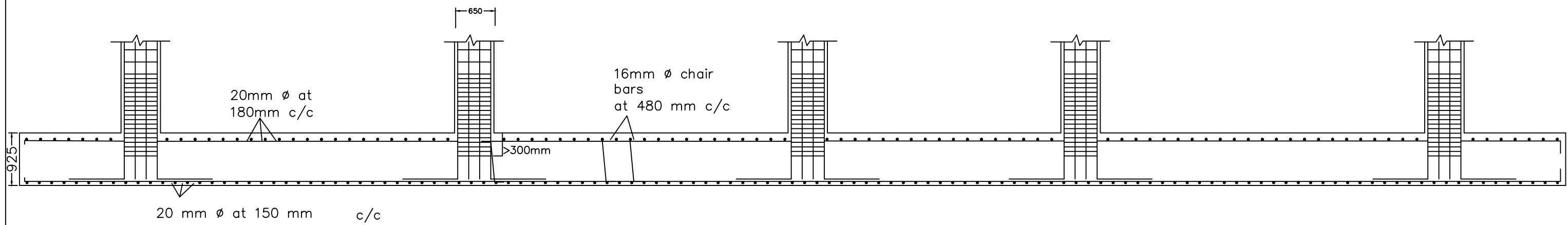

SECTION ALONG Y-Y AXIS

INSTITUTE OF ENGINEERING PULCHOWK CAMPUS PULCHOWL, LALITPUR	PROJECT TITLE	SHEET TITLE	SUBMITTED TO:	SUBMITTED BY:		SCALE: FIT TO SCALE
	EARTHQUAKE RESISTANT DESIGN OF MULTI-STORIED COMMERCIAL BUILDING	REINFORCEMENT SECTIONAL DETAIL OF FOUNDATION OF BUILDING 1	DEPARTMENT OF CIVIL ENGINEERING PULCHOWK CAMPUS	Prakrit Devkota (PUL075BCE101)	Priyanshu Pokhrel (PUL075BCE109)	SHEET NO. 61
				Ram Krishna Kandel (PUL075BCE116)	Rijab Ali Miya (PUL075BCE119)	
				Safal Katwal (PUL075BCE129)	Sangam Poudel (PUL075BCE142)	SUBMISSION DATE:
			PROJECT SUPERVISOR:	Asst. Prof. Aakarsha Khawas		28th April, 2023

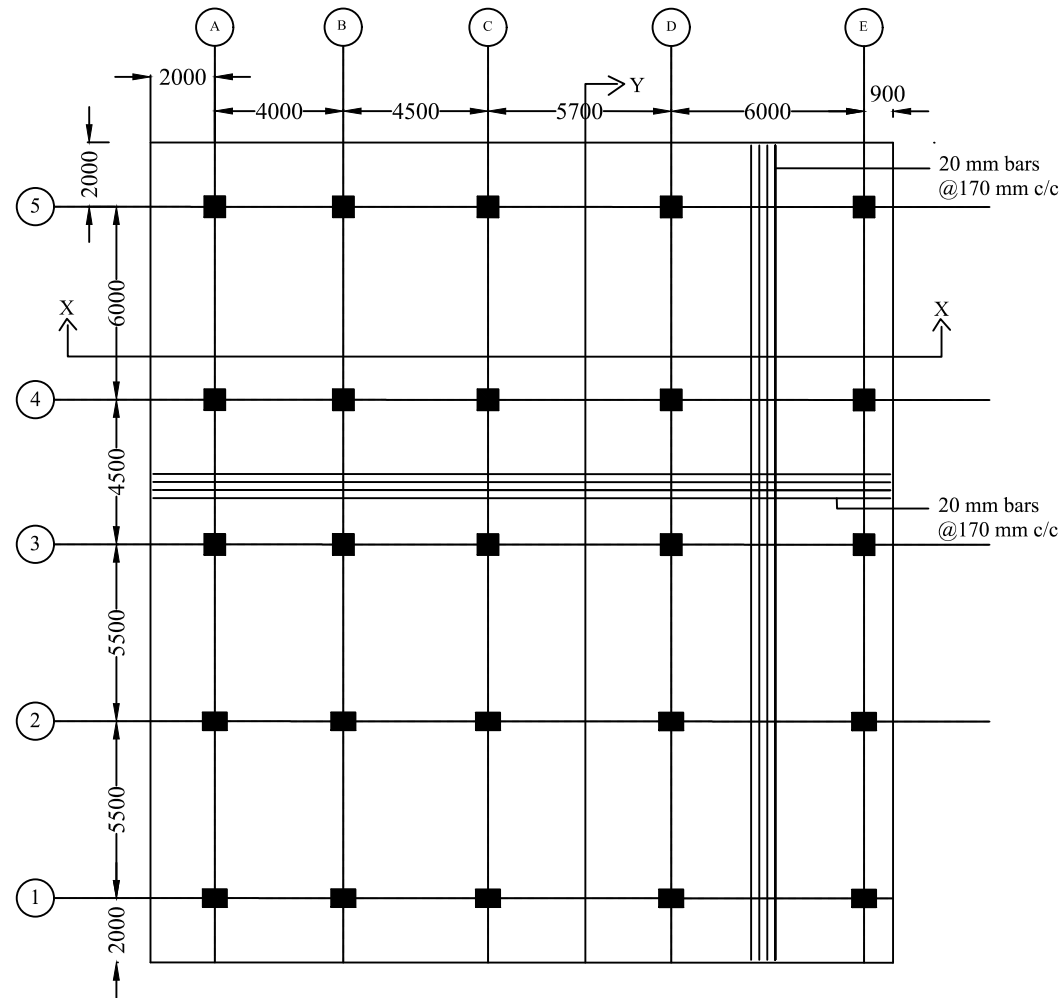

Bottom Reinforcement Bars

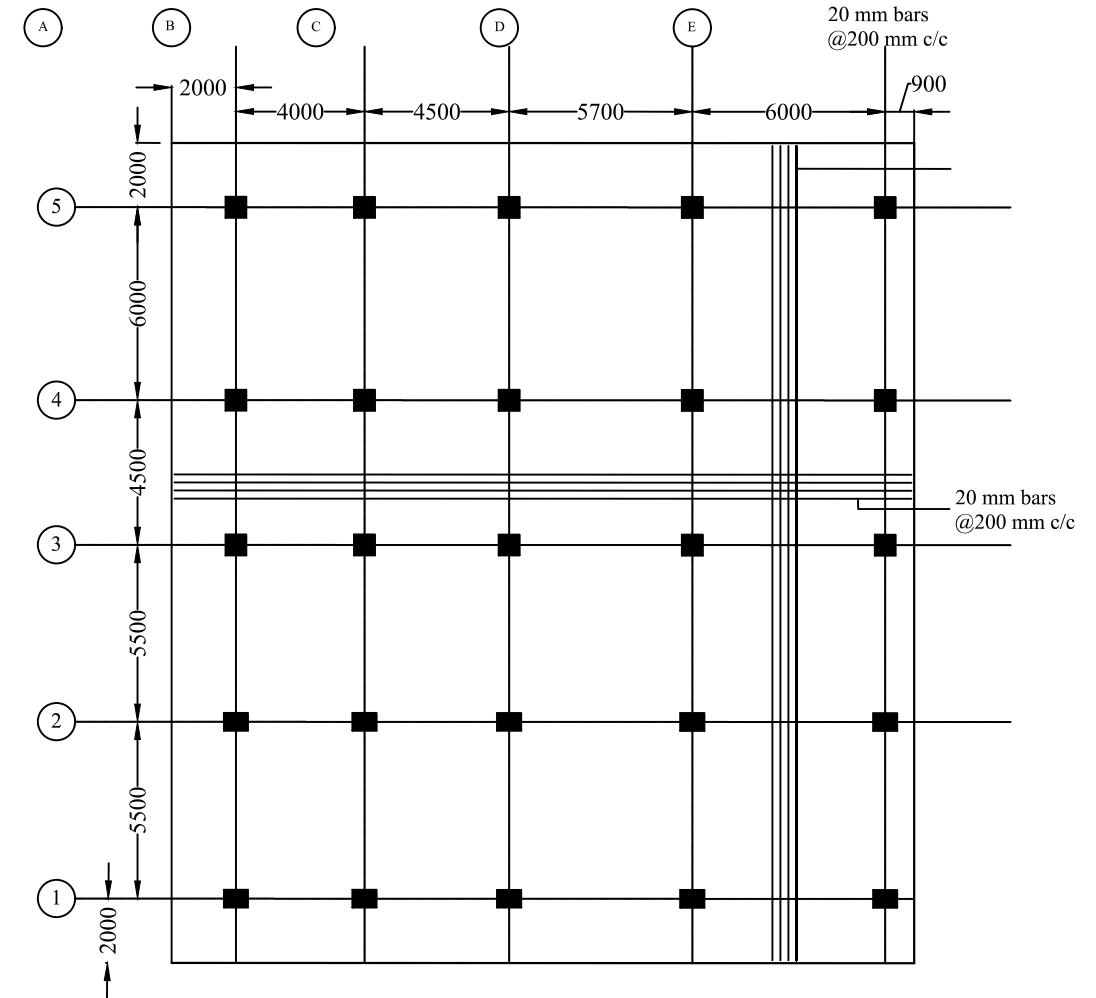

Top Reinforcement Bars

INSTITUTE OF ENGINEERING PULCHOWK CAMPUS PULCHOWK, LALITPUR	PROJECT TITLE	SHEET TITLE	SUBMITTED TO:	SUBMITTED BY:		SCALE: FIT TO SCALE
	EARTHQUAKE RESISTANT ANALYSIS AND DESIGN OF MULTIPURPOSE BUILDING	REINFORCEMENT PLAN OF FOUNDATION OF BUILDING 2	DEPARTMENT OF CIVIL ENGINEERING PULCHOWK CAMPUS	Prakrit Devkota (PUL075BCE101)	Priyanshu Pokhrel (PUL075BCE109)	SHEET NO. 62
				Ram Krishna Kandel (PUL075BCE116)	Rijab Ali Miya (PUL075BCE119)	
				Safal Katwal (PUL075BCE129)	Sangam Poudel (PUL075BCE142)	SUBMISSION DATE: April 2023
			PROJECT SUPERVISOR:	Asst. Prof. Aakarsha Khawas		

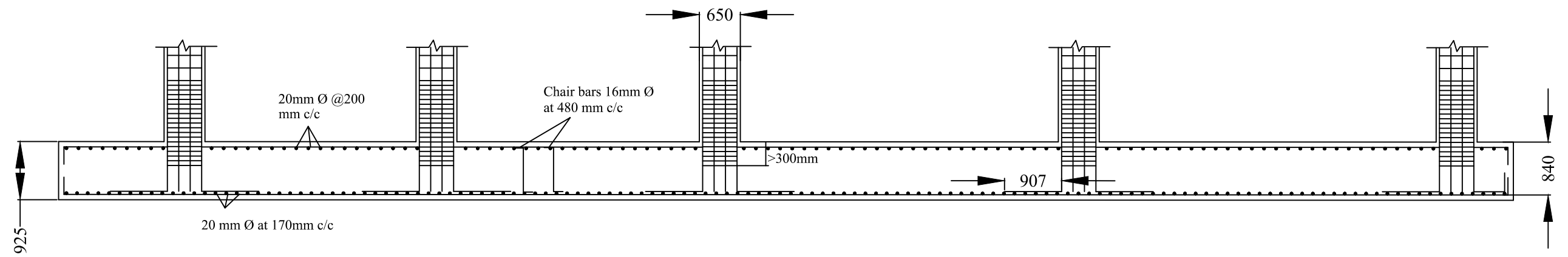

SECTION ALONG X-X AXIS

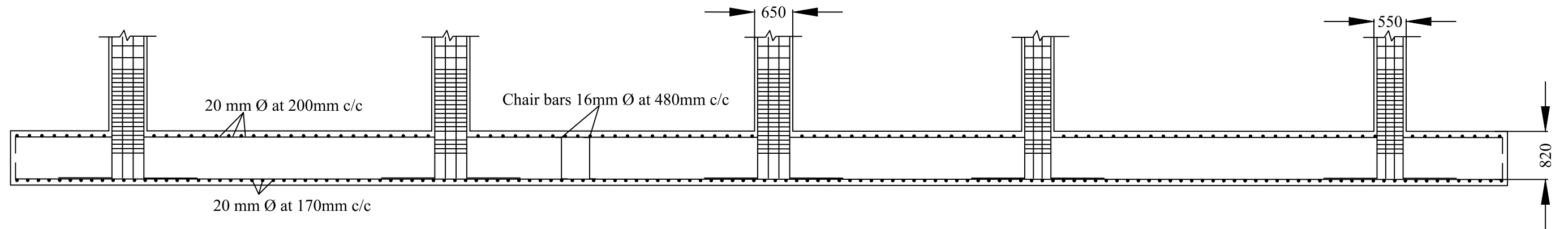

SECTION ALONG Y-Y AXIS

INSTITUTE OF ENGINEERING PULCHOWK CAMPUS PULCHOWK, LALITPUR	PROJECT TITLE	SHEET TITLE	SUBMITTED TO:	SUBMITTED BY:		SCALE: FIT TO SCALE
	EARTHQUAKE RESISTANT ANALYSIS AND DESIGN OF MULTIPURPOSE BUILDING	REINFORCEMENT SECTIONAL DETAIL OF FOUNDATION OF BUILDING 2	DEPARTMENT OF CIVIL ENGINEERING PULCHOWK CAMPUS	Prakrit Devkota (PUL075BCE101)	Priyanshu Pokhrel (PUL075BCE109)	SHEET NO. 63
				Ram Krishna Kandel (PUL075BCE116)	Rijab Ali Miya (PUL075BCE119)	
				Safal Katwal (PUL075BCE129)	Sangam Poudel (PUL075BCE142)	SUBMISSION DATE: April 2023
			PROJECT SUPERVISOR:	Asst. Prof. Aakarsha Khawas		

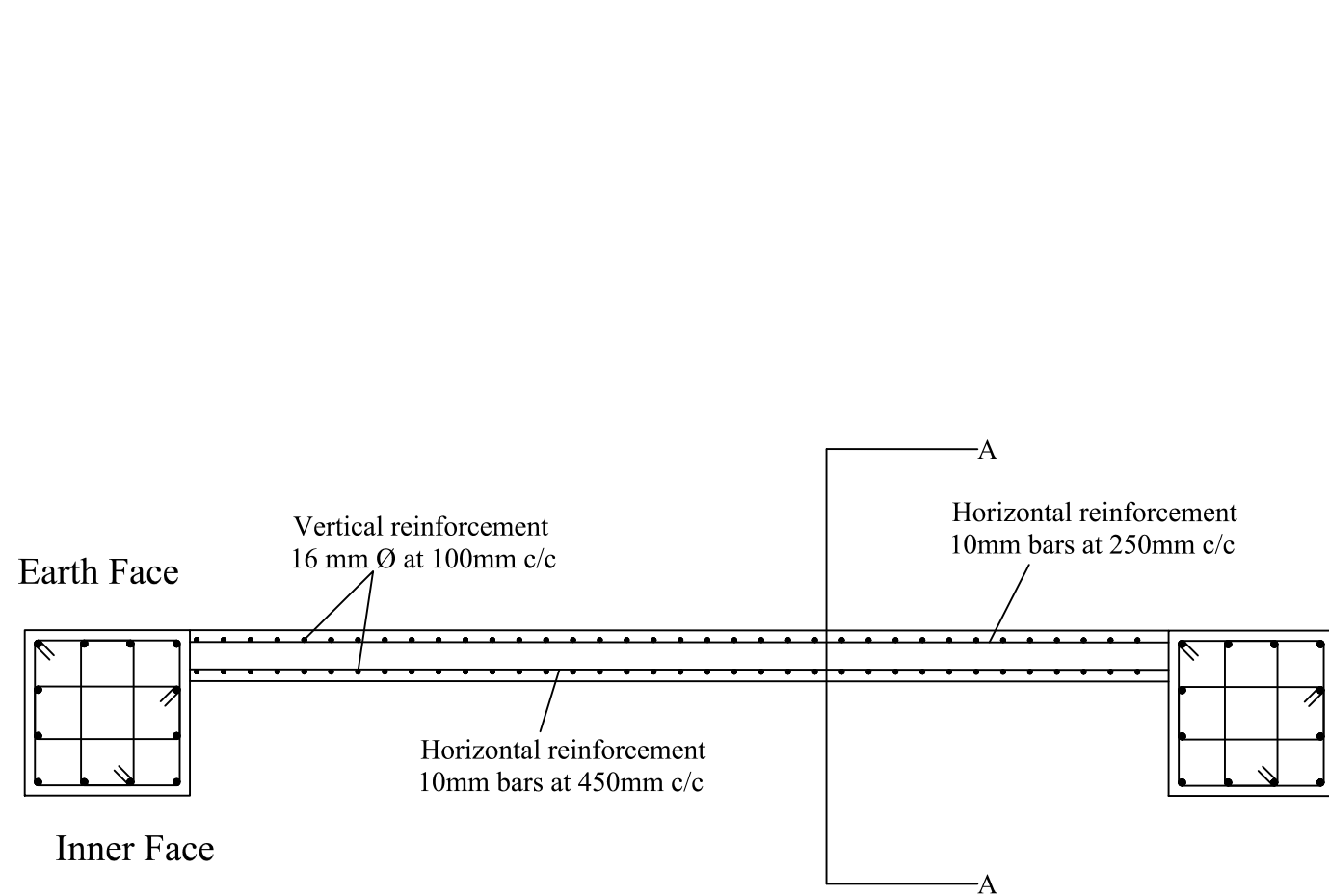

PLAN VIEW

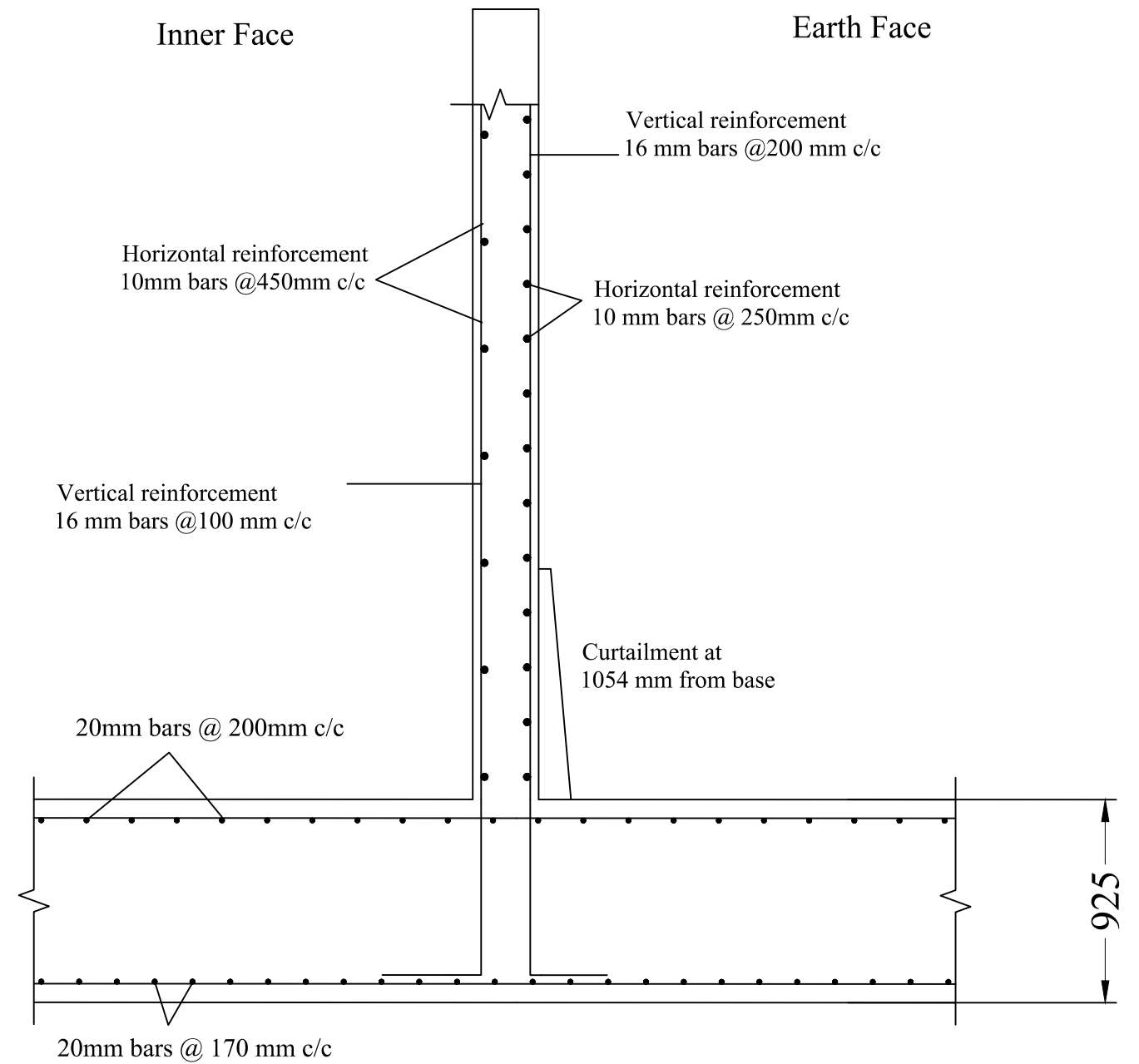

Vertical section at A-A

BASEMENT WALL DETAILING

INSTITUTE OF ENGINEERING PULCHOWK CAMPUS PULCHOWK, LALITPUR	PROJECT TITLE	SHEET TITLE	SUBMITTED TO:	SUBMITTED BY:		SCALE: FIT TO SCALE
	EARTHQUAKE RESISTANT ANALYSIS AND DESIGN OF MULTIPURPOSE BUILDING	BASEMENT WALL DETAILING	DEPARTMENT OF CIVIL ENGINEERING PULCHOWK CAMPUS	Prakrit Devkota (PUL075BCE101)	Priyanshu Pokhrel (PUL075BCE109)	SHEET NO. 64
				Ram Krishna Kandel (PUL075BCE116)	Rijab Ali Miya (PUL075BCE119)	
				Safal Katwal (PUL075BCE129)	Sangam Poudel (PUL075BCE142)	SUBMISSION DATE: April 2023
			PROJECT SUPERVISOR:	Asst. Prof. Aakarsha Khawas		

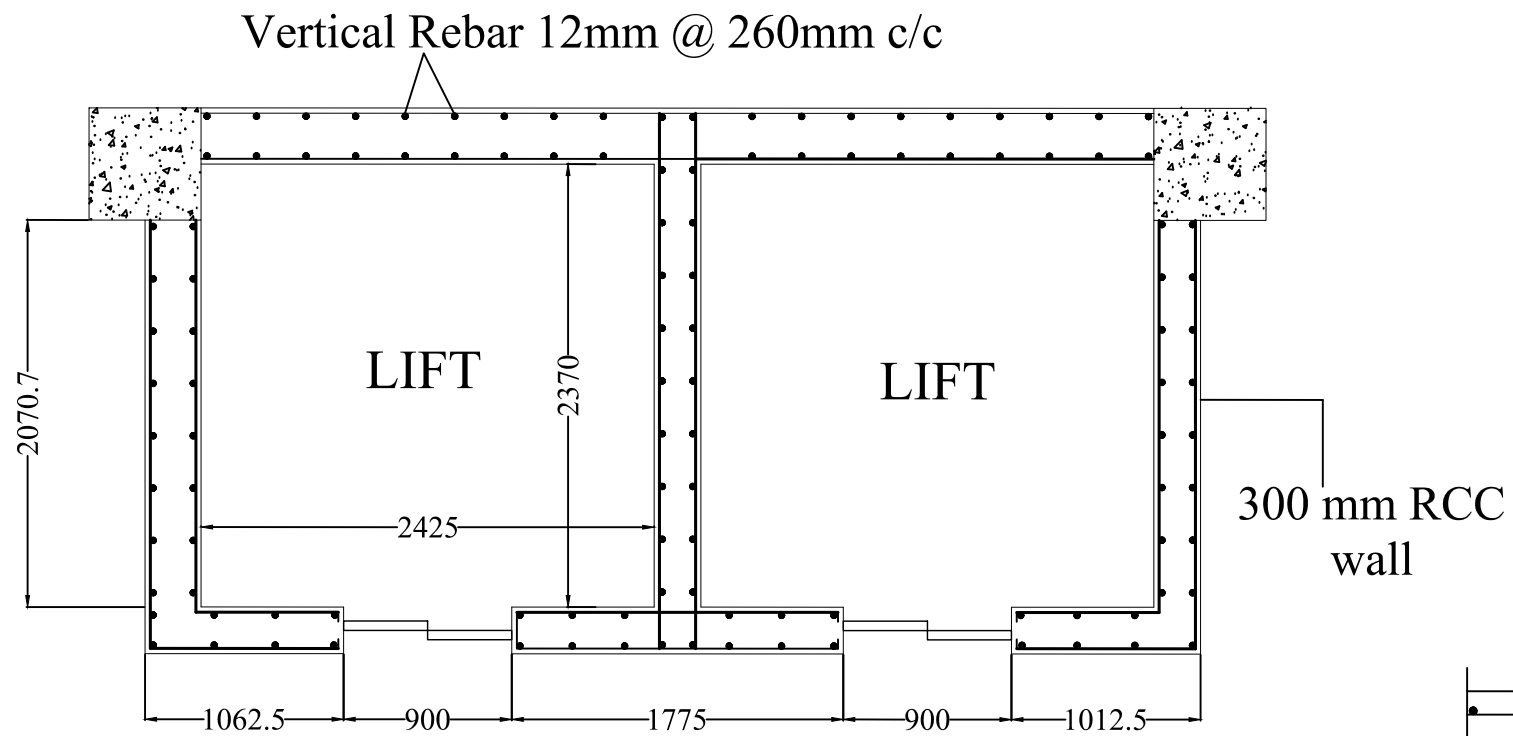

Plan of Lift Wall

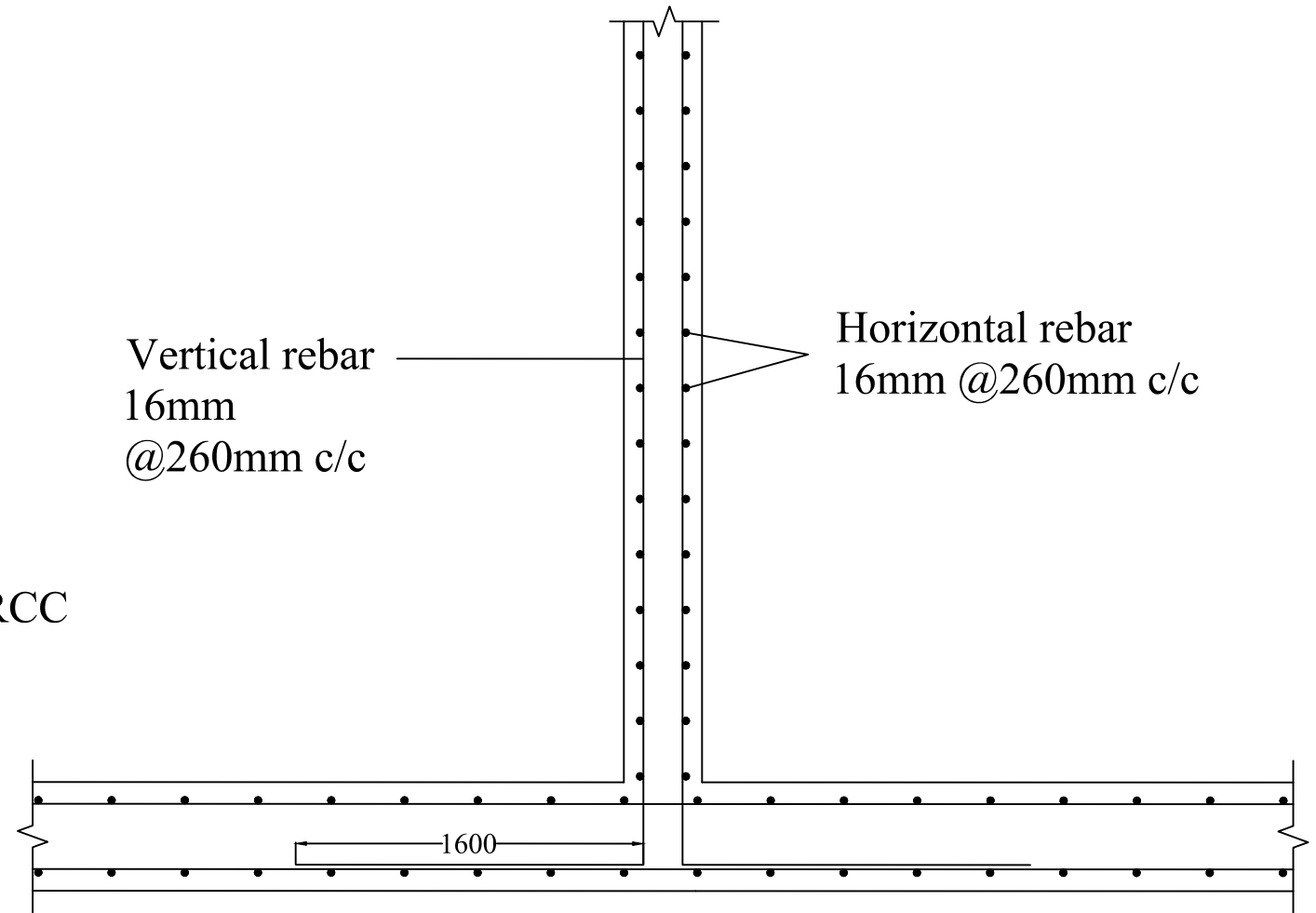

Section of Lift Wall

INSTITUTE OF ENGINEERING PULCHOWK CAMPUS PULCHOWK, LALITPUR	PROJECT TITLE	SHEET TITLE	SUBMITTED TO:	SUBMITTED BY:		SCALE: FIT TO SCALE
	EARTHQUAKE RESISTANT ANALYSIS AND DESIGN OF MULTIPURPOSE BUILDING	REINFORCEMENT DETAILING OF LIFT CORE	DEPARTMENT OF CIVIL ENGINEERING PULCHOWK CAMPUS	Prakrit Devkota (PUL075BCE101)	Priyanshu Pokhrel (PUL075BCE109)	SHEET NO. 65
				Ram Krishna Kandel (PUL075BCE116)	Rijab Ali Miya (PUL075BCE119)	
				Safal Katwal (PUL075BCE129)	Sangam Poudel (PUL075BCE142)	SUBMISSION DATE: April 2023
			PROJECT SUPERVISOR:	Asst. Prof. Aakarsha Khawas		

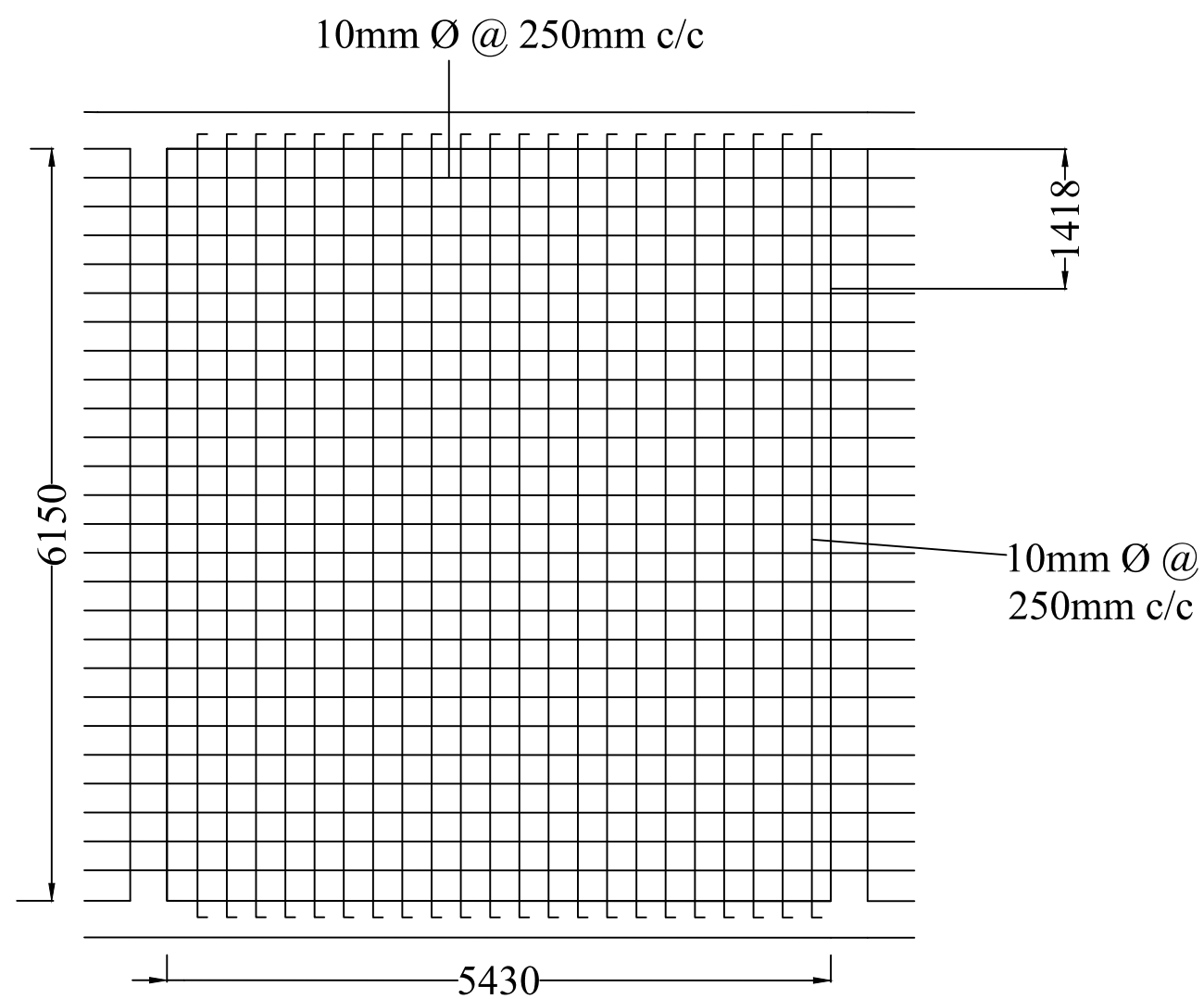

Projected Bottom Bar Plan of Ramp Slab

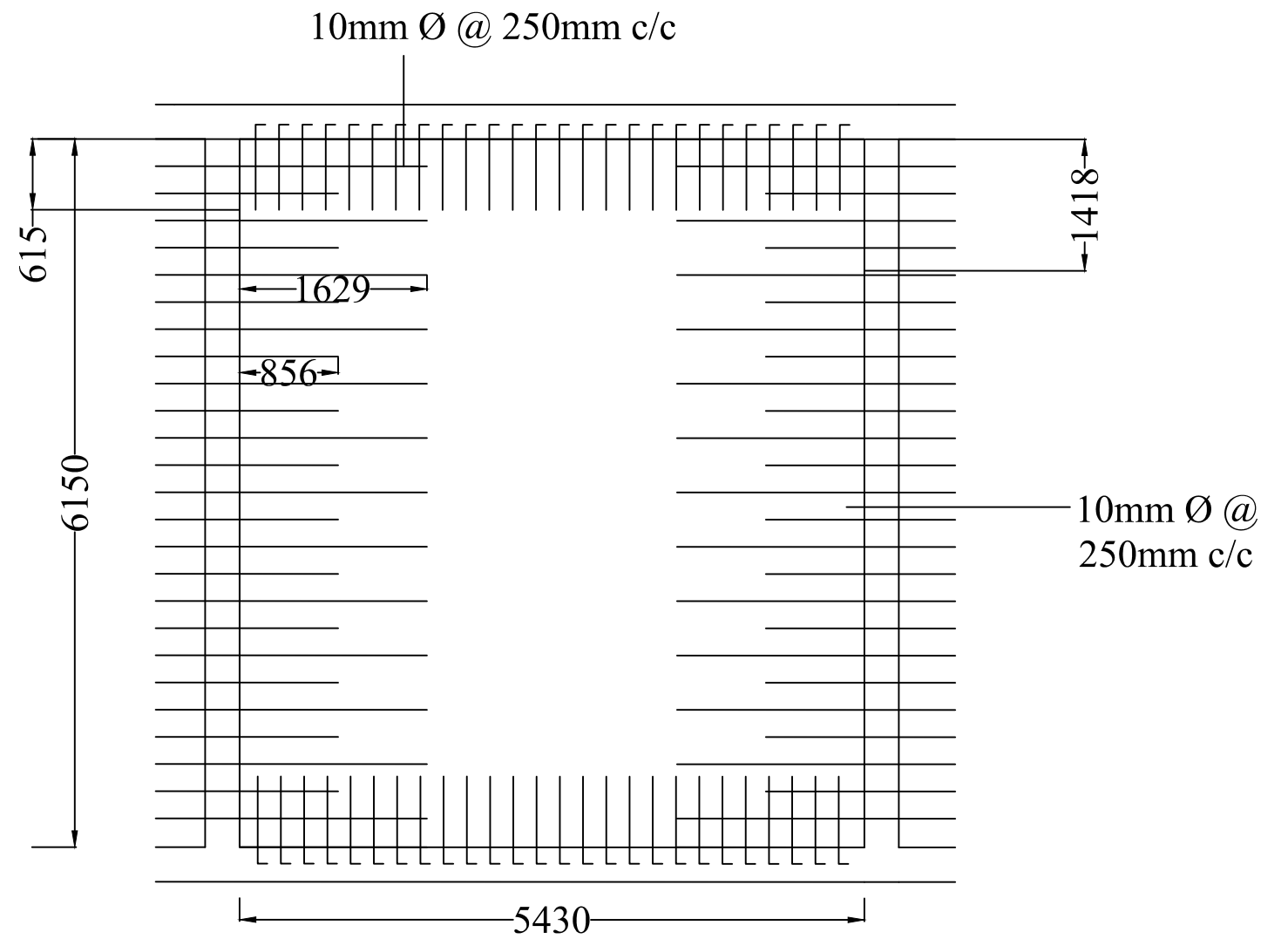

Projected Top Bar Plan of Ramp Slab

INSTITUTE OF ENGINEERING PULCHOWK CAMPUS PULCHOWK, LALITPUR	PROJECT TITLE	SHEET TITLE	SUBMITTED TO:	SUBMITTED BY:		SCALE: FIT TO SCALE
	EARTHQUAKE RESISTANT ANALYSIS AND DESIGN OF MULTIPURPOSE BUILDING	REINFORCEMENT DETAILING OF RAMP SLAB	DEPARTMENT OF CIVIL ENGINEERING PULCHOWK CAMPUS	Prakrit Devkota (PUL075BCE101)	Priyanshu Pokhrel (PUL075BCE109)	SHEET NO. 66
				Ram Krishna Kandel (PUL075BCE116)	Rijab Ali Miya (PUL075BCE119)	
				Safal Katwal (PUL075BCE129)	Sangam Poudel (PUL075BCE142)	SUBMISSION DATE: April 2023
			PROJECT SUPERVISOR:	Asst. Prof. Aakarsha Khawas		

ANNEX D

ANNEX D

Analysis Results Samples

Building 1:

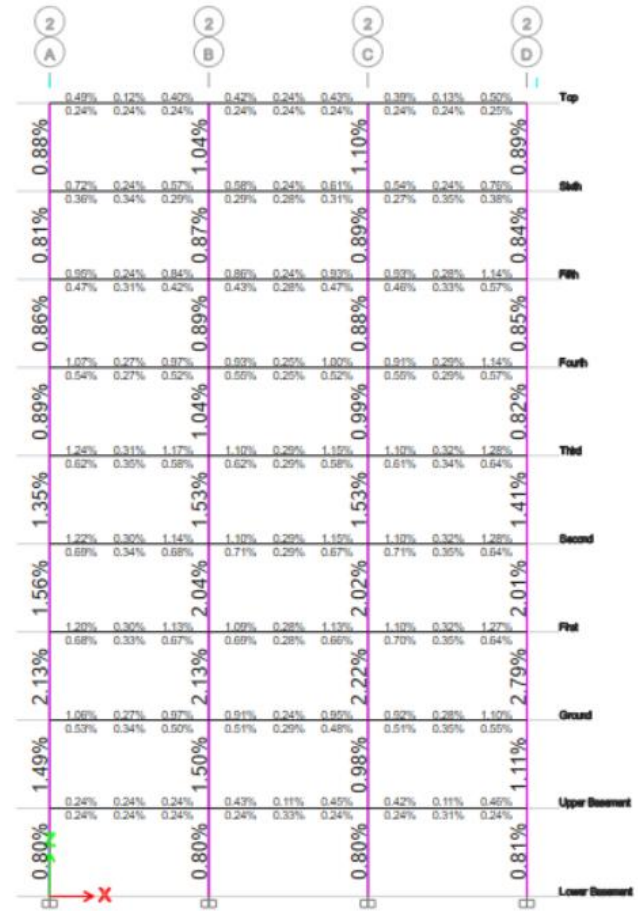
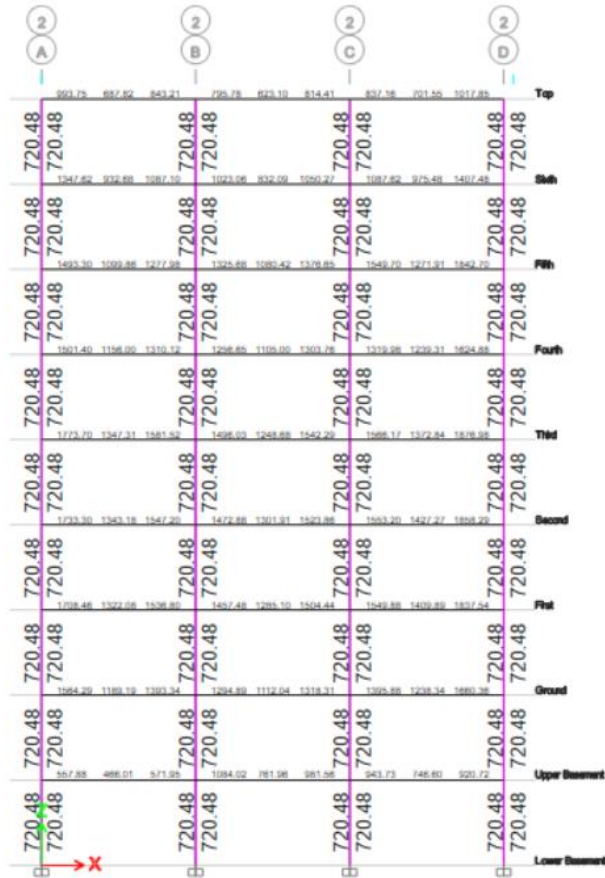

ANNEX D

Centre of Gravity – Brick Walls (Unit Weight of Brick Masonry = 19 kN/m³)

Wall name	Length(m)	Height(m)	Thickness (m)	K	Weight(KN)	X(m)	Y(m)	W*X(KN-m)	W*Y(KN-m)
1st building (first floor-sixth floor)									
A5-B5	3.35	2.95	0.23	1	43.186525	2	21.5	86.37305	928.5102875
B5-C5	3.85	2.95	0.23	1	49.632275	5.6	21.5	277.94074	1067.093913
C5-D5	5.05	2.95	0.23	1	65.102075	10.05	21.5	654.2758538	1399.694613
D5-E5	5.35	2.95	0.23	1	68.969525	15.25	21.5	1051.785256	1482.844788
A1-A2	4.75	2.95	0.23	0.8	48.9877	0	2.375	0	116.3457875
A2-A3	4.75	2.95	0.23	0.8	48.9877	0	7.125	0	349.0373625
A3-A4	3.85	2.95	0.23	0.8	39.70582	0	11.425	0	453.6389935
A4-A5	5.35	2.95	0.23	0.8	55.17562	0	16.025	0	884.1893105
A1-B1	3.25	2.95	0.23	1	41.897375	2	0	83.79475	0
B1-C1	3.75	2.95	0.23	0.8	38.6745	5.5	0	212.70975	0
C1-D1	4.95	2.95	0.23	0.8	51.05034	9.85	0	502.845849	0
D1-E1	5.25	2.95	0.23	0.8	54.1443	14.95	0	809.457285	0
B3-B4	3.85	2.95	0.115	0.8	19.85291	4	13.25	79.41164	263.0510575
B4-B5	5.35	2.95	0.23	1	68.969525	4	18.5	275.8781	1275.936213
C1-C2	4.85	2.95	0.115	1	31.2618875	8.5	2.75	265.7260438	85.97019063
C2-C3	4.85	2.95	0.115	1	31.2618875	8.5	8.25	265.7260438	257.9105719
C4-C5	5.35	2.95	0.23	1	68.969525	8.5	18.5	586.2409625	1275.936213
D3-D4	3.85	2.95	0.115	0.8	19.85291	14.2	13.25	281.911322	263.0510575
D4-D5	5.35	2.95	0.115	0.8	27.58781	14.2	18.5	391.746902	510.374485
A4-B4	3.35	2.95	0.115	0.8	17.27461	2	15.5	34.54922	267.756455
A3-B3	3.35	2.95	0.115	0.8	17.27461	2	11	34.54922	190.02071
C3-D3	5.05	2.95	0.115	1	32.5510375	11.35	11	369.4542756	358.0614125
D3-E3	5.35	2.95	0.115	1	34.4847625	17.2	11	593.137915	379.3323875
C2-D2	4.95	2.95	0.115	1	31.9064625	11.35	5.5	362.1383494	175.4855438
D2-E2	5.25	2.95	0.115	1	33.8401875	17.2	5.5	582.051225	186.1210313
E3-E2	4.85	2.95	0.115	1	31.2618875	20.2	8.25	631.4901275	257.9105719
					Sum			Sum	Sum
					1071.863768			8433.193881	12428.27295

ANNEX D

Wall name	Length(m)	Height(m)	Thickness (m)	K	Weight(KN)	X(m)	Y(m)	W*X(KN-m)	W*Y(KN-m)
1st building (ground floor, top floor)									
A5-B5	3.35	2.95	0.23	0.5	21.5932625	2	21.5	43.186525	464.2551438
B5-C5	3.85	2.95	0.23	0.5	24.8161375	5.6	21.5	138.97037	533.5469563
C5-D5	5.05	2.95	0.23	0.5	32.5510375	10.05	21.5	327.1379269	699.8473063
D5-E5	5.35	2.95	0.23	0.5	34.4847625	15.25	21.5	525.8926281	741.4223938
A1-A2	4.75	2.95	0.23	0.4	24.49385	0	2.375	0	58.17289375
A2-A3	4.75	2.95	0.23	0.4	24.49385	0	7.125	0	174.5186813
A3-A4	3.85	2.95	0.23	0.4	19.85291	0	11.425	0	226.8194968
A4-A5	5.35	2.95	0.23	0.4	27.58781	0	16.025	0	442.0946553
A1-B1	3.25	2.95	0.23	0.5	20.9486875	2	0	41.897375	0
B1-C1	3.75	2.95	0.23	0.4	19.33725	5.5	0	106.354875	0
C1-D1	4.95	2.95	0.23	0.4	25.52517	9.85	0	251.4229245	0
D1-E1	5.25	2.95	0.23	0.4	27.07215	14.95	0	404.7286425	0
B3-B4	3.85	2.95	0.115	0.4	9.926455	4	13.25	39.70582	131.5255288
B4-B5	5.35	2.95	0.23	0.5	34.4847625	4	18.5	137.93905	637.9681063
C1-C2	4.85	2.95	0.115	0.5	15.63094375	8.5	2.75	132.8630219	42.98509531
C2-C3	4.85	2.95	0.115	0.5	15.63094375	8.5	8.25	132.8630219	128.9552859
C4-C5	5.35	2.95	0.23	0.5	34.4847625	8.5	18.5	293.1204813	637.9681063
D3-D4	3.85	2.95	0.115	0.4	9.926455	14.2	13.25	140.955661	131.5255288
D4-D5	5.35	2.95	0.115	0.4	13.793905	14.2	18.5	195.873451	255.1872425
A4-B4	3.35	2.95	0.115	0.4	8.637305	2	15.5	17.27461	133.8782275
A3-B3	3.35	2.95	0.115	0.4	8.637305	2	11	17.27461	95.010355
C3-D3	5.05	2.95	0.115	0.5	16.27551875	11.35	11	184.7271378	179.0307063
D3-E3	5.35	2.95	0.115	0.5	17.24238125	17.2	11	296.5689575	189.6661938
C2-D2	4.95	2.95	0.115	0.5	15.95323125	11.35	5.5	181.0691747	87.74277188
D2-E2	5.25	2.95	0.115	0.5	16.92009375	17.2	5.5	291.0256125	93.06051563
E3-E2	4.85	2.95	0.115	0.5	15.63094375	20.2	8.25	315.7450638	128.9552859
					Sum			Sum	Sum
					535.9318838			4216.59694	6214.136477

ANNEX D

Wall name	Length(m)	Height(m)	Thickness (m)	K	Weight(KN)	X(m)	Y(m)	W*X(KN-m)	W*Y(KN-m)
1st building (roof cover)									
B5-C5	3.85	2.95	0.115	0.5	12.4080688	6.25	21.5	77.55043	266.773478
C5-D5	5.05	2.95	0.115	0.5	16.2755188	11.35	21.5	184.72714	349.923653
B4-C4	3.85	2.95	0.23	0.4	19.85291	6.25	15.5	124.08069	307.720105
C4-D4	5.05	2.95	0.23	0.4	26.04083	11.35	15.5	295.56342	403.632865
B4-B5	5.35	2.95	0.115	0.5	17.2423813	4	18.5	68.969525	318.984053
C4-C5	5.35	2.95	0.23	0.5	34.4847625	8.5	18.5	293.12048	637.968106
D4-D5	5.35	2.95	0.23	0.5	34.4847625	14.2	18.5	489.68363	637.968106
					Sum			Sum	Sum
					160.789234			1533.6953	2922.97037

Center of Gravity – Slabs

Center of mass - SLABS (GF to top floor)								
Slab	Length(m)	Breadth(m)	Thickness(m)	Weight(KN)	X	Y	W*X	W*Y
AB45	4	6	0.15	90	2	18.5	180	1665
AB34	4	4.5	0.15	67.5	2	13.25	135	894.375
AB23	4	5.5	0.15	82.5	2	8.25	165	680.625
AB12	4	5.5	0.15	82.5	2	2.75	165	226.875
BC34	4.5	4.5	0.15	75.9375	6.25	13.25	474.6094	1006.172
BC23	4.5	5.5	0.15	92.8125	6.25	8.25	580.0781	765.7031
BC12	4.5	5.5	0.15	92.8125	6.25	2.75	580.0781	255.2344
CD44'	5.7	2.62	0.15	56.0025	11.35	16.81	635.6284	941.402
CD34	5.7	4.5	0.15	96.1875	11.35	13.25	1091.728	1274.484
CD12	5.7	5.5	0.15	117.5625	11.35	2.75	1334.334	323.2969
DE45	6	6	0.15	135	17.2	18.5	2322	2497.5
DE34	6	4.5	0.15	101.25	17.2	13.25	1741.5	1341.563

ANNEX D

DE12	6	5.5	0.15	123.75	17.2	2.75	2128.5	340.3125
				Sum			Sum	Sum
				1213.815			11533.46	12212.54

Center of mass - SLABS (stair cover)								
Slab	Length(m)	Breadth(m)	Thickness(m)	Weight (KN)	X	Y	W*X	W*Y
BC45	4.5	6	0.15	101.25	6.25	18.5	632.8125	1873.125
CD45	5.7	6	0.15	128.25	11.35	18.5	1455.638	2372.625
				Sum			Sum	Sum
				229.5			2088.45	4245.75

Center of Gravity – Columns

Center of mass - Columns (GF to sixth floor)									
Column	Width(m)	Breadth(m)	Height (m)	K	Weight(KN)	X	Y	W*X	W*Y
A1	0.75	0.55	3.6	1	37.125	0	0	0	0
B1	0.75	0.55	3.6	1	37.125	4	0	148.5	0
C1	0.75	0.55	3.6	1	37.125	8.5	0	315.5625	0
D1	0.75	0.55	3.6	1	37.125	14.2	0	527.175	0
E1	0.75	0.55	3.6	1	37.125	20.2	0	749.925	0
A2	0.75	0.55	3.6	1	37.125	0	5.5	0	204.1875
B2	0.75	0.55	3.6	1	37.125	4	5.5	148.5	204.1875
C2	0.75	0.55	3.6	1	37.125	8.5	5.5	315.5625	204.1875
D2	0.75	0.55	3.6	1	37.125	14.2	5.5	527.175	204.1875
E2	0.75	0.55	3.6	1	37.125	20.2	5.5	749.925	204.1875
A3	0.65	0.65	3.6	1	38.025	0	11	0	418.275
B3	0.65	0.65	3.6	1	38.025	4	11	152.1	418.275

ANNEX D

C3	0.65	0.65	3.6	1	38.025	8.5	11	323.2125	418.275
D3	0.65	0.65	3.6	1	38.025	14.2	11	539.955	418.275
E3	0.65	0.65	3.6	1	38.025	20.2	11	768.105	418.275
A4	0.65	0.65	3.6	1	38.025	0	15.5	0	589.3875
B4	0.65	0.65	3.6	1	38.025	4	15.5	152.1	589.3875
C4	0.65	0.65	3.6	1	38.025	8.5	15.5	323.2125	589.3875
D4	0.65	0.65	3.6	1	38.025	14.2	15.5	539.955	589.3875
E4	0.65	0.65	3.6	1	38.025	20.2	15.5	768.105	589.3875
A5	0.65	0.65	3.6	1	38.025	0	21.5	0	817.5375
B5	0.65	0.65	3.6	1	38.025	4	21.5	152.1	817.5375
C5	0.65	0.65	3.6	1	38.025	8.5	21.5	323.2125	817.5375
D5	0.65	0.65	3.6	1	38.025	14.2	21.5	539.955	817.5375
E5	0.65	0.65	3.6	1	38.025	20.2	21.5		817.5375
					941.625			8064.338	10146.94

Center of mass - Columns (TOP FLOOR)									
Column	Width(m)	Breadth(m)	Height (m)	K	Weight(KN)	X	Y	W*X	W*Y
A1	0.75	0.55	3.6	0.5	18.5625	0	0	0	0
B1	0.75	0.55	3.6	0.5	18.5625	4	0	74.25	0
C1	0.75	0.55	3.6	0.5	18.5625	8.5	0	157.7813	0
D1	0.75	0.55	3.6	0.5	18.5625	14.2	0	263.5875	0
E1	0.75	0.55	3.6	0.5	18.5625	20.2	0	374.9625	0
A2	0.75	0.55	3.6	0.5	18.5625	0	5.5	0	102.0938
B2	0.75	0.55	3.6	0.5	18.5625	4	5.5	74.25	102.0938
C2	0.75	0.55	3.6	0.5	18.5625	8.5	5.5	157.7813	102.0938
D2	0.75	0.55	3.6	0.5	18.5625	14.2	5.5	263.5875	102.0938
E2	0.75	0.55	3.6	0.5	18.5625	20.2	5.5	374.9625	102.0938
A3	0.65	0.65	3.6	0.5	19.0125	0	11	0	209.1375
B3	0.65	0.65	3.6	0.5	19.0125	4	11	76.05	209.1375
C3	0.65	0.65	3.6	0.5	19.0125	8.5	11	161.6063	209.1375

ANNEX D

D3	0.65	0.65	3.6	0.5	19.0125	14.2	11	269.9775	209.1375
E3	0.65	0.65	3.6	0.5	19.0125	20.2	11	384.0525	209.1375
A4	0.65	0.65	3.6	0.5	19.0125	0	15.5	0	294.6938
B4	0.65	0.65	3.6	1	38.025	4	15.5	152.1	589.3875
C4	0.65	0.65	3.6	1	38.025	8.5	15.5	323.2125	589.3875
D4	0.65	0.65	3.6	1	38.025	14.2	15.5	539.955	589.3875
E4	0.65	0.65	3.6	0.5	19.0125	20.2	15.5	384.0525	294.6938
A5	0.65	0.65	3.6	0.5	19.0125	0	21.5	0	408.7688
B5	0.65	0.65	3.6	1	38.025	4	21.5	152.1	817.5375
C5	0.65	0.65	3.6	1	38.025	8.5	21.5	323.2125	817.5375
D5	0.65	0.65	3.6	1	38.025	14.2	21.5	539.955	817.5375
E5	0.65	0.65	3.6	0.5	19.0125	20.2	21.5		408.7688
					584.8875			5047.436	7183.856

Center of mass - Columns (Stair cover)									
Column	Width(m)	Breadth(m)	Height (m)	K	Weight(KN)	X	Y	W*X	W*Y
B5	0.65	0.65	3.6	0.5	19.0125	4	21.5	76.05	408.7688
C5	0.65	0.65	3.6	0.5	19.0125	8.5	21.5	161.6063	408.7688
D5	0.65	0.65	3.6	0.5	19.0125	14.2	21.5	269.9775	408.7688
B4	0.65	0.65	3.6	0.5	19.0125	4	15.5	76.05	294.6938
C4	0.65	0.65	3.6	0.5	19.0125	8.5	15.5	161.6063	294.6938
D4	0.65	0.65	3.6	0.5	19.0125	14.2	15.5	269.9775	294.6938
					114.075			1015.268	2110.388

ANNEX D

Center of Gravity – Primary Beams

Center of mass - primary beams (GF to top floor)								
Beam	Length(m)	Breadth(m)	Depth(m)	Weight(KN)	X	Y	W*X	W*Y
A1-B1	3.25	0.35	0.65	18.484375	2	0	36.96875	0
B1-C1	3.75	0.35	0.65	21.328125	6.25	0	133.300781	0
C1-D1	4.95	0.35	0.65	28.153125	11.35	0	319.537969	0
D1-E1	5.25	0.35	0.65	29.859375	17.2	0	513.58125	0
A2-B2	3.25	0.35	0.65	18.484375	2	5.5	36.96875	101.664063
B2-C2	3.75	0.35	0.65	21.328125	6.25	5.5	133.300781	117.304688
C2-D2	4.95	0.35	0.65	28.153125	11.35	5.5	319.537969	154.842188
D2-E2	5.25	0.35	0.65	29.859375	17.2	5.5	513.58125	164.226563
A3-B3	3.35	0.35	0.65	19.053125	2	11	38.10625	209.584375
B3-C3	3.85	0.35	0.65	21.896875	6.25	1	136.855469	21.896875
C3-D3	5.05	0.35	0.65	28.721875	11.35	11	325.993281	315.940625
D3-E3	5.35	0.35	0.65	30.428125	17.2	11	523.36375	334.709375
A4-B4	3.35	0.35	0.65	19.053125	2	15.5	38.10625	295.323438
B4-C4	3.85	0.5	0.6	28.875	6.25	15.5	180.46875	447.5625
C4-D4	5.05	0.35	0.65	28.721875	11.35	15.5	325.993281	445.189063
D4-E4	5.35	0.35	0.65	30.428125	17.2	15.5	523.36375	471.635938
A5-B5	3.35	0.35	0.65	19.053125	2	21.5	38.10625	409.642188
B5-C5	3.85	0.5	0.6	28.875	6.25	21.5	180.46875	620.8125
C5-D5	5.05	0.35	0.65	28.721875	11.35	21.5	325.993281	617.520313
D5-E5	5.35	0.35	0.65	30.428125	17.2	21.5	523.36375	654.204688
A1-A2	4.8	0.35	0.65	27.3	0	2.75	0	75.075
A2-A3	4.8	0.35	0.65	27.3	0	8.25	0	225.225
A3-A4	3.85	0.35	0.65	21.896875	0	13.25	0	290.133594
A4-A5	5.35	0.35	0.65	30.428125	0	18.5	0	562.920313
B1-B2	4.8	0.35	0.65	27.3	4	2.75	109.2	75.075
B2-B3	4.8	0.35	0.65	27.3	4	8.25	109.2	225.225
B3-B4	3.85	0.35	0.65	21.896875	4	13.25	87.5875	290.133594

ANNEX D

B4-B5	5.35	0.5	0.6	40.125	4	18.5	160.5	742.3125
C1-C2	4.8	0.35	0.65	27.3	8.5	2.75	232.05	75.075
C2-C3	4.8	0.35	0.65	27.3	8.5	8.25	232.05	225.225
C3-C4	3.85	0.35	0.65	21.896875	8.5	13.25	186.123438	290.133594
C4-C5	5.35	0.5	0.6	40.125	8.5	18.5	341.0625	742.3125
D1-D2	4.8	0.35	0.65	27.3	14.2	2.75	387.66	75.075
D2-D3	4.8	0.35	0.65	27.3	14.2	8.25	387.66	225.225
D3-D4	3.85	0.35	0.65	21.896875	14.2	13.25	310.935625	290.133594
D4-D5	5.35	0.35	0.65	30.428125	14.2	18.5	432.079375	562.920313
E1-E2	4.8	0.35	0.65	27.3	20.2	2.75	551.46	75.075
E2-E3	4.8	0.35	0.65	27.3	20.2	8.25	551.46	225.225
E3-E4	3.85	0.35	0.65	21.896875	20.2	13.25	442.316875	290.133594
E4-E5	5.35	0.35	0.65	30.428125	20.2	18.5	614.648125	562.920313
Landing beam	3.85	0.5	0.6	28.875	6.25	21.5	180.46875	620.8125
				Sum			Sum	Sum
				1092.8			10483.4225	12128.4258

Center of mass - primary beams (stair cover)								
Beam	Length(m)	Breadth(m)	Depth(m)	Weight(KN)	X	Y	W*X	W*Y
B4-C4	3.85	0.35	0.65	21.896875	6.25	15.5	136.855469	339.401563
C4-D4	5.05	0.35	0.65	28.721875	11.35	15.5	325.993281	445.189063
B5-C5	3.85	0.35	0.65	21.896875	6.25	21.5	136.855469	470.782813
C5-D5	5.05	0.35	0.65	28.721875	11.35	21.5	325.993281	617.520313
B4-B5	5.35	0.35	0.65	30.428125	4	18.5	121.7125	562.920313
C4-C5	5.35	0.35	0.65	30.428125	8.5	18.5	258.639063	562.920313
D4-D5	5.35	0.35	0.65	30.428125	14.2	18.5	432.079375	562.920313
				192.52188			1738.12844	3561.65469

ANNEX D

Center of Gravity – Secondary Beam

Center of mass - secondary beams (GF to top floor)								
Beam	Length(m)	Breadth(m)	Depth(m)	Weight(KN)	X	Y	W*X	W*Y
D'45	5.65	0.25	0.35	12.359375	17.2	18.5	212.5813	228.64 84
D'34	4.15	0.25	0.35	9.078125	17.2	13.25	156.1438	120.28 52
D'12	5.15	0.25	0.35	11.265625	17.2	2.75	193.7688	30.980 47
C'12	5.15	0.25	0.35	11.265625	11.35	2.75	127.8648	30.980 47
CD4'	5.2705	0.25	0.35	11.529219	11.35	18.12	130.8566	208.90 94
				55.497969			821.2152	619.80 4

Center of Gravity – Staircase

Center of mass- staricase (GF to 6th floor)							
Element	Area	Thickness	Weight	X	Y	W*X	W*Y
Landing slab 1	3.465	0.175	15.15938	6.25	15.885	94.74609	240.8067
Landing slab 2	8.685	0.175	37.99688	6.25	20.535	237.4805	780.2658
Waist slab 1	7.52	0.175	32.9	5.175	17.92	170.2575	589.568
Waist slab 2	7.52	0.175	32.9	7.325	17.92	240.9925	589.568
			118.9563			743.4766	2200.209
Center of mass- staircase (Top floor)							
Element	Area	Thickness	Weight	X	Y	W*X	W*Y
Landing slab 1	3.465	0.175	15.15938	6.25	15.885	94.74609	240.8067
Landing slab 2	4.3425	0.175	18.99844	6.25	20.535	118.7402	390.1329
Waist slab	7.52	0.175	32.9	7.325	17.92	240.9925	589.568
			67.05781			454.4788	1220.508

ANNEX D

Center of Gravity – Basement Wall

Wall name	Length(m)	Height(m)	Thickness (m)	Weight(KN)	X(m)	Y(m)	W*X(KN-m)	W*Y(KN-m)
A1A2	4.75	2.95	0.2	35.03125	0	2.75	0	96.33594
A2A3	4.8	2.95	0.2	35.4	0	8.25	0	292.05
A3A4	3.85	2.95	0.2	28.39375	0	13.25	0	376.2172
A4A5	5.35	2.95	0.2	39.45625	0	18.5	0	729.9406
A1B1	3.25	2.95	0.2	23.96875	2	0	47.9375	0
B1C1	3.75	2.95	0.2	27.65625	6.25	0	172.8516	0
C1D1	4.95	2.95	0.2	36.50625	11.35	0	414.3459	0
D1E1	5.25	2.95	0.2	38.71875	17.2	0	665.9625	0
A5B5	3.25	2.95	0.2	23.96875	2	21.5	47.9375	515.3281
B5C5	3.75	2.95	0.2	27.65625	6.25	21.5	172.8516	594.6094
C5D5	4.95	2.95	0.2	36.50625	11.35	21.5	414.3459	784.8844
D5E5	5.25	2.95	0.2	38.71875	17.2	21.5	665.9625	832.4531
				391.9813			2602.195	4221.819

Overall COM Compilation

Ground Floor

Element	W(KN)	W*X	W*Y	COM(X)	COM(Y)
Wall	535.9319	4216.597	6214.136	8.841225	9.841225
Primary beam	1092.8	10483.42	12128.43		
Slabs	1213.815	11533.46	12212.54		
Column	941.625	8064.338	10146.94		
Secondary beam	55.49797	821.2152	619.804		
Staircase	118.9563	743.4766	2200.209		
Basement wall	391.9813	2602.195	4221.819		
	4350.607	38464.7	42815.31		

ANNEX D

First Floor

Element	W(KN)	W*X	W*Y	COM(X)	COM(Y)
Wall	1071.864	8433.194	12428.27	8.917251	9.917251
Primary beam	1092.8	10483.42	12128.43		
Slabs	1213.815	11533.46	12212.54		
Column	941.625	8064.338	10146.94		
Secondary beam	55.49797	821.2152	619.804		
Staircase	118.9563	743.4766	2200.209		
	4494.558	40079.1	44573.66		

Second Floor

Element	W(KN)	W*X	W*Y	COM(X)	COM(Y)
Wall	1071.864	8433.194	12428.27	8.917251	9.917251
Primary beam	1092.8	10483.42	12128.43		
Slabs	1213.815	11533.46	12212.54		
Column	941.625	8064.338	10146.94		
Secondary beam	55.49797	821.2152	619.804		
Staircase	118.9563	743.4766	2200.209		
	4494.558	40079.1	44573.66		

Third Floor

Element	W(KN)	W*X	W*Y	COM(X)	COM(Y)
Wall	1071.864	8433.194	12428.27	8.917251	9.917251
Primary beam	1092.8	10483.42	12128.43		
Slabs	1213.815	11533.46	12212.54		
Column	941.625	8064.338	10146.94		
Secondary beam	55.49797	821.2152	619.804		

ANNEX D

Staircase	118.9563	743.4766	2200.209		
	4494.558	40079.1	44573.66		

Fourth Floor

Element	W(KN)	W*X	W*Y	COM(X)	COM(Y)
Wall	1071.864	8433.194	12428.27	8.917251	9.917251
Primary beam	1092.8	10483.42	12128.43		
Slabs	1213.815	11533.46	12212.54		
Column	941.625	8064.338	10146.94		
Secondary beam	55.49797	821.2152	619.804		
Staircase	118.9563	743.4766	2200.209		
	4494.558	40079.1	44573.66		

Fifth Floor

Element	W(KN)	W*X	W*Y	COM(X)	COM(Y)
Wall	1071.864	8433.194	12428.27	8.917251	9.917251
Primary beam	1092.8	10483.42	12128.43		
Slabs	1213.815	11533.46	12212.54		
Column	941.625	8064.338	10146.94		
Secondary beam	55.49797	821.2152	619.804		
Staircase	118.9563	743.4766	2200.209		
	4494.558	40079.1	44573.66		

ANNEX D

Sixth Floor

Element	W(KN)	W*X	W*Y	COM(X)	COM(Y)
Wall	1071.864	8433.194	12428.27	8.917251	9.917251
Primary beam	1092.8	10483.42	12128.43		
Slabs	1213.815	11533.46	12212.54		
Column	941.625	8064.338	10146.94		
Secondary beam	55.49797	821.2152	619.804		
Staircase	118.9563	743.4766	2200.209		
	4494.558	40079.1	44573.66		

Top Floor

Element	W(KN)	W*X	W*Y	COM(X)	COM(Y)
Wall	535.9319	4216.597	6214.136	9.1709	10.1709
Primary beam	1092.8	10483.42	12128.43		
Slabs	1213.815	11533.46	12212.54		
Column	584.8875	5047.436	7183.856		
Secondary beam	55.49797	821.2152	619.804		
Staircase	67.05781	454.4788	1220.508		
	3549.99	32556.61	36106.6		

Stair Cover

Element	W(KN)	W*X	W*Y	COM(X)	COM(Y)
Wall	160.7892	1533.695	2922.97	9.148613	18.42591
Primary beam	192.5219	1738.128	3561.655		
Slabs	229.5	2088.45	4245.75		
Column	114.075	1015.268	2110.388		
	696.8861	6375.541	12840.76		

ANNEX D

						2304134	2933670			21612777.2	28892528.9
Center of stiffness - basement wall											
Wall	Lx(m)	Ly(m)	lx(m)	ly(m)	H(m)	Kx	Ky	X	Y	Kx*X	Ky*Y
A1A2	0.2	4.75	1.786198	0.003167	2.95	22865221.3	40536.68035	0	2.75	0	111475.871
A2A3	0.2	4.8	1.8432	0.0032	2.95	23594908.2	40963.38225	0	8.25	0	337947.904
A3A4	0.2	3.85	0.95111	0.002567	2.95	12175218.6	32856.04618	0	13.25	0	435342.612
A4A5	0.2	5.35	2.552173	0.003567	2.95	32670510.9	45657.10313	0	18.5	0	844656.408
A1B1	3.25	0.2	0.002167	0.572135	2.95	27735.6234	7323938.054	2	0	55471.25	0
B1C1	3.75	0.2	0.0025	0.878906	2.95	32002.6424	11250928.96	6.25	0	200016.5	0
C1D1	4.95	0.2	0.0033	2.021456	2.95	42243.4879	25876776.58	11.35	0	479463.6	0
D1E1	5.25	0.2	0.0035	2.411719	2.95	44803.6993	30872549.07	17.2	0	770623.6	0
A5B5	3.25	0.2	0.002167	0.572135	2.95	27735.6234	7323938.054	2	21.5	55471.25	157464668
B5C5	3.75	0.2	0.0025	0.878906	2.95	32002.6424	11250928.96	6.25	21.5	200016.5	241894973
C5D5	4.95	0.2	0.0033	2.021456	2.95	42243.4879	25876776.58	11.35	21.5	479463.6	556350697
D5E5	5.25	0.2	0.0035	2.411719	2.95	44803.6993	30872549.07	17.2	21.5	770623.6	663759805
						91599429.8	150808398.6			3011150	1621199565

Center of stiffness-stair cover											
Column	Lx(m)	Ly(m)	lx(m)	ly(m)	H(m)	Kx	Ky	X	Y	Kx*X	Ky*Y
B4	0.65	0.65	0.014876	0.014876	3.6	104779.6	104779.6	4	15.5	419118.226	1624083.126
C4	0.65	0.65	0.014876	0.014876	3.6	104779.6	104779.6	8.5	15.5	890626.23	1624083.126
D4	0.65	0.65	0.014876	0.014876	3.6	104779.6	104779.6	14.2	15.5	1487869.7	1624083.126
B5	0.65	0.65	0.014876	0.014876	3.6	104779.6	104779.6	4	21.5	419118.226	2252760.465
C5	0.65	0.65	0.014876	0.014876	3.6	104779.6	104779.6	8.5	21.5	890626.23	2252760.465
D5	0.65	0.65	0.014876	0.014876	3.6	104779.6	104779.6	14.2	21.5	1487869.7	2252760.465
						628677.3	628677.3			5595228.32	11630530.77

ANNEX D

Overall Center of Stiffness

Ground floor						
Element	Kx	Ky	Kx*X	Ky*Y	COR(X)	COR(Y)
Column	2304134.03	2933669.832	21612777.2	28892528.9	0.262226	10.73286
Basement wall	91599429.8	150808398.6	3011149.96	1621199565		
Sum	93903563.9	153742068.4	24623927.2	1650092094		
For 1st-top floor						
Element	Kx	Ky	Kx*X	Ky*Y	COR(X)	COR(Y)
Column	2304134.03	2933669.832	21612777.2	28892528.9	9.38	9.848596
For stair cover						
Element	Kx	Ky	Kx*X	Ky*Y	COR(X)	COR(Y)
Column	628677.339	628677.3391	5595228.32	11630530.8	8.9	18.5

Calculation for Foundation Design

SN	Joint element	P(KN)	MX	MY	Coordinate		P*X	P*Y
					X	Y		
26	C15 Column	658.113	8.1127	-8.8735	2	2	1316.226	1316.23
182	Basement joint	103.8972	1.4365	-1.2825	2	2.3438	207.7944	243.514
177	Basement joint	107.1412	1.8101	-3.0541	2	2.6875	214.2824	287.942
183	Basement joint	102.8953	1.859	-5.004	2	3.0313	205.7906	311.907
185	Basement joint	99.0023	1.6998	-6.6368	2	3.375	198.0046	334.133
188	Basement joint	94.8726	1.3902	-7.8688	2	3.7188	189.7452	352.812

ANNEX D

191	Basement joint	92.4399	0.9407	-8.7043	2	4.0625	184.8798	375.537
192	Basement joint	91.5742	0.4304	-9.1933	2	4.4063	183.1484	403.503
189	Basement joint	93.4353	-0.1025	-9.3784	2	4.75	186.8706	443.818
186	Basement joint	97.4875	-0.6202	-9.2878	2	5.0938	194.975	496.582
180	Basement joint	104.1888	-1.0534	-8.9231	2	5.4375	208.3776	566.527
171	Basement joint	111.8228	-1.3905	-8.2673	2	5.7813	223.6456	646.481
148	Basement joint	121.4797	-1.4935	-7.2939	2	6.125	242.9594	744.063
129	Basement joint	130.0525	-1.4784	-6.0007	2	6.4688	260.105	841.284
102	Basement joint	140.9034	-1.1331	-4.4709	2	6.8125	281.8068	959.904
95	Basement joint	144.7419	-0.7431	-3.143	2	7.1563	289.4838	1035.82
23	C16 Column	980.9481	1.9282	61.6026	2	7.5	1961.8962	7357.11
94	Basement joint	145.0126	1.2108	-3.1299	2	7.8438	290.0252	1137.45
96	Basement joint	144.3496	1.6855	-4.4385	2	8.1875	288.6992	1181.86
120	Basement joint	134.4332	1.936	-5.9444	2	8.5313	268.8664	1146.89
138	Basement joint	126.596	1.9625	-7.212	2	8.875	253.192	1123.54

ANNEX D

152	Basement joint	118.8347	1.8435	-8.1617	2	9.2188	237.6694	1095.51
170	Basement joint	112.9734	1.5043	-8.8008	2	9.5625	225.9468	1080.31
175	Basement joint	108.4003	1.0486	-9.1628	2	9.9063	216.8006	1073.85
179	Basement joint	106.6164	0.5168	-9.2759	2	10.25	213.2328	1092.82
176	Basement joint	107.1883	-0.0277	-9.151	2	10.5938	214.3766	1135.53
172	Basement joint	110.7321	-0.5121	-8.7779	2	10.9375	221.4642	1211.13
163	Basement joint	115.643	-0.915	-8.1296	2	11.2813	231.286	1304.6
145	Basement joint	122.915	-1.1057	-7.1725	2	11.625	245.83	1428.89
131	Basement joint	129.5801	-1.1862	-5.8997	2	11.9688	259.1602	1550.92
111	Basement joint	138.6234	-0.9566	-4.3916	2	12.3125	277.2468	1706.8
101	Basement joint	142.1939	-0.6951	-3.0825	2	12.6563	284.3878	1799.65
24	C17 Column	945.9041	0.7833	60.3355	2	13	1891.8082	12296.8
89	Basement joint	145.7741	0.8075	-3.1347	2	13.3462	291.5482	1945.53
88	Basement joint	146.154	1.0884	-4.4796	2	13.6923	292.308	2001.18
106	Basement joint	139.9855	1.2129	-5.9959	2	14.0385	279.971	1965.19

ANNEX D

115	Basement joint	136.281	1.1165	-7.2252	2	14.3846	272.562	1960.35
122	Basement joint	133.383	0.9048	-8.0621	2	14.7308	266.766	1964.84
125	Basement joint	132.4332	0.5063	-8.4858	2	15.0769	264.8664	1996.68
123	Basement joint	133.237	0.094	-8.5011	2	15.4231	266.474	2054.93
118	Basement joint	135.2989	-0.3114	-8.1103	2	15.7692	270.5978	2133.56
108	Basement joint	139.8222	-0.4969	-7.3135	2	16.1154	279.6444	2253.29
97	Basement joint	143.6487	-0.5892	-6.1339	2	16.4615	287.2974	2364.67
79	Basement joint	150.469	-0.298	-4.6765	2	16.8077	300.938	2529.04
74	Basement joint	153.2733	-0.0839	-3.3783	2	17.1538	306.5466	2629.22
21	C6 Column	1013.8514	6.9893	56.6285	2	17.5	2027.7028	17742.4
104	Basement joint	140.3184	1.6723	-3.1962	2	17.8333	280.6368	2502.34
107	Basement joint	139.979	2.2043	-4.385	2	18.1667	279.958	2542.96
133	Basement joint	128.5556	2.4092	-5.7817	2	18.5	257.1112	2378.28
154	Basement joint	118.6507	2.4572	-6.9945	2	18.8333	237.3014	2234.58
174	Basement joint	108.9535	2.3731	-7.9438	2	19.1667	217.907	2088.28

ANNEX D

184	Basement joint	100.6699	2.0954	-8.6327	2	19.5	201.3398	1963.06
190	Basement joint	93.2572	1.7004	-9.0917	2	19.8333	186.5144	1849.6
194	Basement joint	87.9793	1.2121	-9.3496	2	20.1667	175.9586	1774.25
196	Basement joint	84.8046	0.6789	-9.422	2	20.5	169.6092	1738.49
197	Basement joint	84.3608	0.1254	-9.3046	2	20.8333	168.7216	1757.51
195	Basement joint	86.2114	-0.4343	-8.9754	2	21.1667	172.4228	1824.81
193	Basement joint	90.7374	-0.9532	-8.3902	2	21.5	181.4748	1950.85
187	Basement joint	96.4709	-1.4241	-7.4985	2	21.8333	192.9418	2106.28
181	Basement joint	104.0535	-1.7305	-6.248	2	22.1667	208.107	2306.52
173	Basement joint	110.2772	-1.8956	-4.6384	2	22.5	220.5544	2481.24
158	Basement joint	117.2252	-1.7565	-2.7513	2	22.8333	234.4504	2676.64
161	Basement joint	116.1691	-1.3586	-1.0617	2	23.1667	232.3382	2691.25
25	C1 Column	801.1373	-8.1409	-3.7785	2	23.5	1602.2746	18826.7
178	Basement joint	107.0973	1.2461	-0.8267	2.3333	2	249.89013	214.195
135	Basement joint	127.5517	-1.1537	-0.4698	2.3333	23.5	297.61638	2997.46
167	Basement joint	114.3426	2.744	-1.0792	2.6667	2	304.91741	228.685

ANNEX D

121	Basement joint	133.5254	-2.6537	-0.6225	2.6667	23.5	356.07218	3137.85
162	Basement joint	116.0658	4.413	-1.1192	3	2	348.1974	232.132
116	Basement joint	135.9311	-4.3089	-0.6754	3	23.5	407.7933	3194.38
153	Basement joint	118.6607	5.7353	-0.9308	3.3333	2	395.53171	237.321
105	Basement joint	140.2083	-5.5893	-0.407	3.3333	23.5	467.35633	3294.9
150	Basement joint	120.4579	6.6016	-0.6367	3.6667	2	441.68298	240.916
98	Basement joint	143.2543	-6.3765	-0.0309	3.6667	23.5	525.27054	3366.48
142	Basement joint	123.9646	6.9827	-0.2779	4	2	495.8584	247.929
83	Basement joint	148.9106	-6.624	0.4251	4	23.5	595.6424	3499.4
136	Basement joint	127.3797	6.8894	0.0493	4.3333	2	551.97445	254.759
71	Basement joint	154.232	-6.3215	0.8381	4.3333	23.5	668.33353	3624.45
124	Basement joint	132.8371	6.3507	0.2193	4.6667	2	619.91089	265.674
63	Basement joint	162.4098	-5.466	1.0306	4.6667	23.5	757.91781	3816.63
112	Basement joint	137.6147	5.4161	0.3062	5	2	688.0735	275.229
56	Basement joint	168.7531	-4.0783	1.1092	5	23.5	843.7655	3965.7

ANNEX D

91	Basement joint	145.1817	4.2118	0.1308	5.3333	2	774.29756	290.363
43	Basement joint	177.6883	-2.2588	0.745	5.3333	23.5	947.66501	4175.68
82	Basement joint	149.5962	3.1119	0.0197	5.6667	2	847.71679	299.192
39	Basement joint	182.6127	-0.4015	0.4266	5.6667	23.5	1034.8114	4291.4
22	C 14 Column	1000.0568	41.5288	-7.7284	6	2	6000.3408	2000.11
6	C 23 Column	3424.2952	-8.1149	7.4355	6	7.5	20545.771	25682.2
9	C 24 Column	3286.6426	1.6374	6.0566	6	13	19719.856	42726.4
4	C7 Column	4255.081	-25.0827	7.6406	6	17.5	25530.486	74463.9
15	C2 Column	1262.6739	24.5593	-5.0141	6	23.5	7576.0434	29672.8
203	basment joint	19.6519	0.6351	-0.5089	6.175	18.27	121.35048	359.04
70	basment joint	154.7589	3.2359	-1.3757	6.3462	2	982.13093	309.518
29	basment joint	196.0031	1.2709	-1.4255	6.3462	23.5	1243.8749	4606.07
201	basment joint	45.7774	1.3035	0.8924	6.5083	18.27	297.93305	836.353
68	basment joint	156.9675	4.4001	-1.7054	6.6923	2	1050.4736	313.935
30	basment joint	194.0967	1.6744	-1.9238	6.6923	23.5	1298.9533	4561.27
202	basment joint	42.1936	1.3781	1.3729	6.8417	18.27	288.67595	770.877
78	basment joint	151.0765	5.6767	-1.7964	7.0385	2	1063.3519	302.153
32	basment joint	190.3649	2.1999	-2.1453	7.0385	23.5	1339.8833	4473.58
199	basment joint	58.2389	1.5438	2.6937	7.175	18.27	417.86411	1064.02
86	basment joint	147.7117	6.6952	-1.6303	7.3846	2	1090.7918	295.423
34	basment joint	187.227	2.4969	-2.1137	7.3846	23.5	1382.5965	4399.83
200	basment joint	51.9171	1.8154	3.2523	7.5083	18.27	389.80916	948.525
92	basment joint	145.1708	7.3664	-1.3431	7.7308	2	1122.2864	290.342
36	basment joint	185.0888	2.6372	-1.8345	7.7308	23.5	1430.8845	4349.59
198	basment joint	79.6137	2.2657	5.0051	7.8417	18.27	624.30675	1454.54
93	basment joint	145.026	7.6804	-0.8685	8.0769	2	1171.3605	290.052

ANNEX D

38	basment joint	184.12	2.6787	-1.3689	8.0769	23.5	1487.1188	4326.82
	Staircase joint	-57.3656	0.6619	6.2411	8.175	18.27	-468.9638	-1048.1
87	basment joint	146.809	7.6436	-0.3953	8.4231	2	1236.5869	293.618
37	basment joint	184.4156	2.5975	-0.8292	8.4231	23.5	1553.351	4333.77
81	basment joint	150.0943	7.2567	0.0493	8.7692	2	1316.2069	300.189
35	basment joint	186.1107	2.451	-0.3428	8.7692	23.5	1632.042	4373.6
69	basment joint	155.8214	6.5138	0.2481	9.1154	2	1420.3744	311.643
33	basment joint	188.2945	2.2375	-0.0394	9.1154	23.5	1716.3797	4424.92
64	basment joint	161.1973	5.4265	0.3335	9.4615	2	1525.1683	322.395
31	basment joint	191.9796	1.9054	0.019	9.4615	23.5	1816.415	4511.52
55	basment joint	169.9373	4.0876	0.0501	9.8077	2	1666.6941	339.875
28	basment joint	196.1412	1.2205	-0.1667	9.8077	23.5	1923.694	4609.32
49	basment joint	175.1573	2.8561	-0.1266	10.1538	2	1778.5122	350.315
27	basment joint	199.2862	0.6512	-0.5985	10.1538	23.5	2023.5122	4683.23
				-				
20	C 13 Column	1133.9813	33.9109	11.4108	10.5	2	11906.804	2267.96
5	C22 Column	3685.4005	3.8419	3.1589	10.5	7.5	38696.705	27640.5
8	C 25 Column	3298.3802	-4.3379	-1.1331	10.5	13	34632.992	42878.9
3	C 18 Column	4591.4342	-16.2104	5.4011	10.5	17.5	48210.059	80350.1
				-				
14	C3 Column	1281.0491	5.0036	12.8607	10.5	23.5	13451.016	30104.7
60	basment joint	163.3874	2.7119	-2.0048	10.8353	2	1770.3515	326.775
42	basment joint	178.4552	-1.4614	-2.5015	10.8353	23.5	1933.6156	4193.7
58	basment joint	165.035	3.8404	-2.5857	11.1706	2	1843.54	330.07
46	basment joint	175.9107	-3.7846	-3.1055	11.1706	23.5	1965.0281	4133.9
72	basment joint	154.1805	5.1064	-2.81	11.5059	2	1773.9854	308.361
65	basment joint	160.9041	-6.2998	-3.3936	11.5059	23.5	1851.3465	3781.25
90	basment joint	145.3356	6.1885	-2.7907	11.8412	2	1720.9479	290.671
84	basment joint	148.5603	-8.5662	-3.4107	11.8412	23.5	1759.1322	3491.17
113	basment joint	136.533	7.0138	-2.625	12.1765	2	1662.4941	273.066

ANNEX D

114	basment joint	136.3098	-10.4303	-3.2264	12.1765	23.5	1659.7763	3203.28
130	basment joint	130.0252	7.5936	-2.2255	12.5118	2	1626.8493	260.05
139	basment joint	126.4417	-11.8387	-2.7399	12.5118	23.5	1582.0133	2971.38
140	basment joint	125.2137	7.9608	-1.7016	12.8471	2	1608.6329	250.427
155	basment joint	118.3891	-12.774	-2.091	12.8471	23.5	1520.9566	2782.14
144	basment joint	123.105	8.1459	-1.074	13.1824	2	1622.8194	246.21
168	basment joint	113.9113	-13.2398	-1.3125	13.1824	23.5	1501.6243	2676.92
141	basment joint	124.1622	8.1642	-0.4583	13.5176	2	1678.375	248.324
169	basment joint	113.2564	-13.2454	-0.5201	13.5176	23.5	1530.9547	2661.53
134	basment joint	128.3211	8.0152	0.1621	13.8529	2	1777.6194	256.642
160	basment joint	116.3375	-12.8026	0.254	13.8529	23.5	1611.6118	2733.93
119	basment joint	135.1625	7.6821	0.6629	14.1882	2	1917.7126	270.325
143	basment joint	123.1733	-11.9266	0.8877	14.1882	23.5	1747.6074	2894.57
99	basment joint	143.2048	7.1332	1.0282	14.5235	2	2079.8349	286.41
126	basment joint	131.6271	-10.6416	1.3666	14.5235	23.5	1911.6862	3093.24
73	basment joint	153.6466	6.3344	1.1048	14.8588	2	2283.0041	307.293
100	basment joint	142.8743	-8.9979	1.5123	14.8588	23.5	2122.9406	3357.55
62	basment joint	162.8842	5.2733	1.055	15.1941	2	2474.8788	325.768
75	basment joint	153.1893	-7.0784	1.4877	15.1941	23.5	2327.5735	3599.95
48	basment joint	175.1793	4.02	0.6405	15.5294	2	2720.4294	350.359
57	basment joint	167.4944	-5.0603	1.0774	15.5294	23.5	2601.0875	3936.12
41	basment joint	180.6659	2.9001	0.2597	15.8647	2	2866.2103	361.332
51	basment joint	173.4627	-3.3675	0.6774	15.8647	23.5	2751.9337	4076.37
16	C 12 Column	1236.2838	37.2488	10.3635	16.2	2	20027.798	2472.57
7	C21 Column	3315.0462	17.6959	-1.0717	16.2	7.5	53703.748	24862.8
10	C20 Column	2854.3945	-24.5465	4.0463	16.2	13	46241.191	37107.1
2	C19 Column	4755.6775	-14.4668	12.0173	16.2	17.5	77041.976	83224.4
17	C4 Column	1233.1943	-51.9799	-5.8741	16.2	23.5	19977.748	28980.1
50	basment joint	174.8575	2.8618	-2.1433	16.5333	2	2890.9715	349.715

ANNEX D

54	basment joint	171.1486	-2.7453	-1.82	16.5333	23.5	2829.6511	4021.99
45	basment joint	176.2945	3.9468	-2.8724	16.8667	2	2973.5064	352.589
52	basment joint	173.0717	-3.6833	-2.5549	16.8667	23.5	2919.1484	4067.18
61	basment joint	163.0808	5.1653	-3.2106	17.2	2	2804.9898	326.162
66	basment joint	160.7332	-4.8482	-2.9027	17.2	23.5	2764.611	3777.23
77	basment joint	151.9171	6.199	-3.2812	17.5333	2	2663.6081	303.834
80	basment joint	150.2211	-5.8411	-2.9798	17.5333	23.5	2633.8716	3530.2
103	basment joint	140.3873	6.9818	-3.1928	17.8667	2	2508.2578	280.775
109	basment joint	139.3146	-6.5939	-2.8953	17.8667	23.5	2489.0922	3273.89
127	basment joint	130.9064	7.5321	-2.8421	18.2	2	2382.4965	261.813
128	basment joint	130.3981	-7.1244	-2.5502	18.2	23.5	2373.2454	3064.36
147	basment joint	122.6376	7.8862	-2.3512	18.5333	2	2272.8794	245.275
146	basment joint	122.6562	-7.4759	-2.0614	18.5333	23.5	2273.2242	2882.42
157	basment joint	117.2741	8.0867	-1.726	18.8667	2	2212.5753	234.548
156	basment joint	117.7855	-7.6881	-1.44	18.8667	23.5	2222.2237	2767.96
166	basment joint	114.3602	8.1512	-1.0682	19.2	2	2195.7158	228.72
165	basment joint	115.4171	-7.7821	-0.778	19.2	23.5	2216.0083	2712.3
164	basment joint	115.4941	8.0937	-0.3927	19.5333	2	2255.9809	230.988
159	basment joint	117.0642	-7.7631	-0.0945	19.5333	23.5	2286.6501	2751.01
151	basment joint	119.2854	7.8955	0.2957	19.8667	2	2369.8073	238.571
149	basment joint	121.4229	-7.6166	0.6064	19.8667	23.5	2412.2723	2853.44
137	basment joint	126.6111	7.5328	0.8968	20.2	2	2557.5442	253.222
132	basment joint	129.5014	-7.3091	1.223	20.2	23.5	2615.9283	3043.28
117	basment joint	135.7329	6.9535	1.4289	20.5333	2	2787.0444	271.466
110	basment joint	139.2904	-6.7877	1.7794	20.5333	23.5	2860.0916	3273.32
85	basment joint	147.8304	6.1076	1.7361	20.8667	2	3084.7326	295.661
76	basment joint	152.3086	-5.991	2.0958	20.8667	23.5	3178.1779	3579.25
67	basment joint	158.7962	4.9567	1.9033	21.2	2	3366.4794	317.592
59	basment joint	163.5702	-4.8768	2.2682	21.2	23.5	3467.6882	3843.9
53	basment joint	171.7139	3.5426	1.6582	21.5333	2	3697.5669	343.428

ANNEX D

44	basment joint	176.7717	-3.4775	1.9585	21.5333	23.5	3806.478	4154.13
47	basment joint	175.8479	2.1364	1.138	21.8667	2	3845.2133	351.696
40	basment joint	180.7566	-2.0901	1.3755	21.8667	23.5	3952.5503	4247.78
19	C11 Column	1140.7035	17.7467	0.108	22.2	2	25323.618	2281.41
12	C10 Column	2373.3786	-0.6889	32.8448	22.2	7.5	52689.005	17800.3
13	C9 Column	2075.8025	-1.7011	28.4449	22.2	13	46082.816	26985.4
11	C8 Column	2727.0918	-8.7908	42.8354	22.2	17.5	60541.438	47724.1
18	C5 Column	1200.2039	-22.7238	2.0732	22.2	23.5	26644.527	28204.8
		78511.1431	105.2285	748.616			881881.53	1029667