

TRIBHUVAN UNIVERSITY
INSTITUTE OF ENGINEERING
PULCHOWK CAMPUS
DEPARTMENT OF ARCHITECTURE
LALITPUR



जलजीवालयः
FRESHWATER AQUARIUM AND RESEARCH
CENTER

IN PARTIAL FULFILLMENT
OF THE REQUIREMENTS FOR THE DEGREE
Bachelor's in Architecture

By
AVISHEK KADEL
074/BAE/207

APRIL 2023

COPYRIGHT

The author has given permission for this thesis to be made publicly available for inspection by the library, the department of architecture, the Pulchowk Campus, and the Institute of Engineering. Also, the author has consented that the professor who oversaw the work documented in this thesis, or, in their absence, the head of the department where the thesis was completed, may provide permission for substantial copying of this thesis for scholarly purposes. It is understood that credit will be given to the project report's author and the Department of Architecture at the Institute of Engineering's Pulchowk Campus for any usage of the project report's content. Without the authorized consent of the Department of Architecture, Pulchowk Campus, Institute of Engineering, and the author, it is forbidden to copy, publish, or exploit this thesis in any other way for financial advantage. Please contact the following if you would like to duplicate or otherwise utilize any of the content in this thesis, in whole or in part:

Head

Department of Architecture

Pulchowk Campus, Institute of Engineering

Pulchowk, Lalitpur

Nepal

CERTIFICATE

This is to certify that this thesis entitled “जलजीवालय: **Freshwater Aquarium and Research Center**” at Panchase Marga, Pokhara submitted by Mr. Avishek Kadel has been examined and has been declared successful for the partial fulfillment of the academic requirement for the completion of the Degree of Bachelor of Architecture.

.....

Asso. Prof. Dr. Ashim Ratna Bajracharya

(Thesis Supervisor)

Date:

Department of Architecture,

Institute of Engineering,

Pulchowk Campus,

Tribhuvan University

DECLARATION

I declare that this dissertation has not been previously accepted in substance for any degree and is not being concurrently submitted in candidature for any degree. I state that this dissertation is the result of my own independent investigation/work, except where otherwise stated. I hereby give consent for my dissertation, if accepted to be available for photocopying and understand that any reference to or quotation from my thesis will receive an acknowledgement.

.....

Avishek Kadel

074/BAE/207

Date: March 02, 2023

To,
The Chairperson and Members of the Jury,
Thesis Committee
Department of Architecture,
Central Campus, Pulchowk,
Institute of Engineering,
Tribhuvan University

Subject: Approval for Final Thesis Presentation

Dear Sir/Madam,

In compliance with the requirement of the course AR 851 (V Year Architectural Design Thesis) for the degree of Bachelor's in Architecture, I hereby respectfully present my thesis for evaluation and approval.

Project Title: जलजीवालय: **Freshwater Aquarium and Research Center**

Project Location: **Panchase Marga, Pokhara**

Respectfully,
Avishek Kadel
074-BAE-207
(Thesis Candidate)

Recommending Approval:

Thesis Supervisor
Thesis Co-Ordinator
Asso. Prof. Dr. Ashim Ratna Bajracharya

External Jury

Head of Department, Pulchowk Campus
Asso. Prof. Dr. Sanjay Upreti

ACKNOWLEDGEMENTS

I would like to express my sincere gratitude to the Department of Architecture, Pulchowk Campus for providing this opportunity to research and prepare this report which indeed helped me to gain the knowledge about architectural requirements and space design of Freshwater Aquarium and Research Center.

I would also like to express my gratification to my supervisor, **Asso. Prof. Dr. Ashim Ratna Bajracharya**, for his continual support and invaluable suggestions and guidance throughout the course of this research.

Nevertheless, I am also thankful to my seniors and friends for their direct and indirect help and support and have been critical about my research helping me to improve this study as well as the report.

ABSTRACT

A good research center design requires good research center knowledge. Knowledge about the various requirements of a research center makes a complete research center which is functionally, aesthetically, and structurally sound.

Freshwater Aquarium and Research Center is a project completely devoted to the study and exhibition of aquatic plants and animals from the various strata, as well as from other sources of water in an interesting and informative manner with the motives of entertaining and educating the visitors.

Freshwater Aquarium and Research Center would help better our knowledge of the aquatic plants and animals and about their life. The behavior and ways of the animals being held captive can be studied without going out in the actual environment. This is especially vital in today's world where a number of wild aquatic animals are becoming extinct.

Freshwater Aquarium and Research Center have to be designed as according to their respected requirements. However, freshwater Aquarium and Research Center includes different spaces like the research center, aquarium space, rainforest exhibit, laboratory space. Thus, this report contains detail information about these spaces which is an important part of a research Centre design.

Contents

CERTIFICATE	iii
ACKNOWLEDGEMENTS	vi
ABSTRACT.....	vii
1.0 Project Overview	1
1.1 Introduction.....	1
1.2 Overview in Global Context	2
1.3 Overview in Nepalese Context	3
1.4 Rationale of Project.....	4
1.5 Importance of Research	5
1.6 Aquarium Objectives	5
1.7 Research Objectives.....	6
1.8 Research Methodology	6
2.0 Literature Review.....	8
2.1 Public Aquarium	8
2.1.1 History of Public Aquariums	8
2.1.2 Development of Public Aquarium	9
2.1.3 Public Aquariums Today	10
2.1.4 Benefits of Public Aquarium:	11
2.2 General Planning Guidelines:	14
2.2.1 Considerations from the Planning perspective:	14
2.3 Space Classification in a public Aquarium:.....	15
2.3.1 Exhibition Galleries	15
A. Tanks.....	16
B. Types of Display tanks in an aquarium.....	18
2.3.2 Quarantine Areas	30
2.3.3 Loading and Receiving Areas	31
2.3.4 Administrative Areas	32
2.3.5 Operation and Maintenance Areas:.....	32
2.3.6 Supporting Areas:	34
2.4 Water Quality in an Aquarium.....	51
2.5 Water Systems in an Aquarium	52
2.5.1 Open Systems.....	53
2.5.2 Closed Systems	54

2.6	Balanced System in Aquarium.....	55
2.7	Life Supporting Systems in an Aquarium.....	56
2.7.1	Plumbing	57
2.7.2	Filtration.....	57
2.8	Universal Design.....	63
2.8.1	Ramp	63
2.8.2	Parking	64
2.8.3	Entrance	64
2.8.4	Toilet Design.....	65
2.8.5	Circulation.....	65
2.9	Disaster management	66
2.10	Rainwater Harvesting.....	68
3.0	Case Studies	69
3.1	Central Zoo (Aquarium)	69
3.1.1	Introduction.....	69
3.1.2	Layout	69
3.1.3	Filtration Process	70
3.1.4	Summary	71
3.2	National Botanical Garden.....	71
3.2.1	Introduction.....	71
3.2.2	Layout	71
3.2.3	Inferences.....	74
3.3	Nepal Agriculture Research Council (Fisheries research Division)	75
3.3.1	Introduction.....	75
3.3.2	Site Plan	75
3.3.3	Layout	75
3.3.4	Water Inlet and Outlet.....	76
3.3.4	Summary	77
3.4	The Taraporewala Aquarium	77
3.4.1	Introduction.....	77
3.4.2	History.....	77
3.4.3	Design Basis.....	77
3.4.4	The location	78
3.4.5	The site and zoning	78

3.4.6 The Built From.....	79
3.4.7 The Planning and Interiors.....	79
3.4.8 Services.....	79
3.4.9 Critical Analysis.....	80
3.4.10 Inferences.....	80
3.5 Monterey Bay Aquarium.....	81
3.5.1 Introduction.....	81
3.5.2 History.....	81
3.5.3 Site.....	82
3.5.4 Architectural Form.....	83
3.5.5 Galleries and Major Exhibits.....	84
3.5.6 Other Facilities.....	85
3.5.7 Seawater System.....	85
3.5.8 Inferences.....	85
3.6 The Blue Planet, Denmark.....	86
3.5.1 Introduction.....	86
3.5.2 History.....	86
3.5.3 Concept.....	86
3.5.4 Planning.....	87
3.5.6 Structural Considerations:.....	90
3.5.7 Inferences:.....	91
4.0 Site Analysis.....	92
4.1 Selection of the site.....	92
4.2 SWOT Analysis.....	92
4.3 Site Analysis Data.....	93
4.4 Inference from Site:.....	96
5.0 Program Formulation.....	97
6.0 Concept.....	104
6.1 Vision for the project.....	104
6.2 Site Context.....	104
6.3 Zoning.....	104
6.4 Concept.....	106
6.5 Exhibition Themes.....	107
6.6 Detailed Design Development.....	108

6.6.1 Entry & Landscape	108
6.6.2 Admin Block.....	108
6.6.3 Aquarium Block A.....	109
6.6.4 Jungle Trail	109
6.6.5 Lake View Restaurant.....	109
6.6.6 Aquarium Block B	110
6.6.7 Joint block.....	110
6.7 Area Analysis:.....	111
7.0 Services	114
7.1. Water Supply	114
7.2. Sanitary	116
8.0 3D Visualization	117
8.1. 3D Visualization	117
8.2. Physical Model.....	125
9.0 References.....	128

List of Figures

Figure 1. 1: Glass Pot Bowl (Fish Keeping)	1
Figure 1. 2: Large Modern Aquarium.....	1
Figure 1. 3: Fish House, London Zoo	2
Figure 1. 4: Methodology of Project.....	7
Figure 2. 1: Public Aquarium.....	8
Figure 2. 2: Artificial Fishponds, Egyptian Period.....	8
Figure 2. 3: Whale shark in Georgia Aquarium's largest aquarium.....	11
Figure 2. 4: Sea turtle rescue.....	11
Figure 2. 5: Research Setup	11
Figure 2. 6: Educating Kids with the help of games.....	12
Figure 2. 7: Touch Tank.....	12
Figure 2. 8: Tourists in Public Aquarium	13
Figure 2. 9: Antalya Aquarium, Turkey.....	13
Figure 2. 10: Interior of Public aquarium	15
Figure 2. 11: Display Area of Public Aquarium	15
Figure 2. 12: Research Tanks.....	16
Figure 2. 13: Display Tank	17
Figure 2. 14: Saltwater Aquarium.....	18
Figure 2. 15: Tropical aquarium	18
Figure 2. 16: Freshwater & Brackish water fishes compatibility chart	19
Figure 2. 17: Vanishing Wall Tank.....	20
Figure 2. 18: Typical Vanishing Side wall tank	20
Figure 2. 19: Touch Tank.....	20
Figure 2. 20: Acrylic Aquarium Tank Tunnel	20
Figure 2. 21: Rectangular Tunnel	21
Figure 2. 22: Alignment.....	22
Figure 2. 23: Excavation, Insertion of pile foundation and Tunnel	22
Figure 2. 24: Connection.....	23
Figure 2. 25: Tunnel sizes	23
Figure 2. 26: Tank layout.....	24
Figure 2. 27: Varied Display tank positions	24
Figure 2. 28: Visitor's flow pattern	24
Figure 2. 29: Visitors flow pattern.....	24
Figure 2. 30: Quarantine Tanks	30
Figure 2. 31: Fish transportation technique	31
Figure 2. 32: Various method of Transportation	32
Figure 2. 33: Behind the scenes area (Maintenance area)	32
Figure 2. 34: Education Center	35
Figure 2. 35: Fish draw	35
Figure 2. 36: River Dance.....	35
Figure 2. 37: Discovering waterways	35
Figure 2. 38: River Cleaning game	36

Figure 2. 39: Shelving standard for adults	36
Figure 2. 40: Shelving standard for children	36
Figure 2. 41: Study area and services	37
Figure 2. 42: Stacking Area	37
Figure 2. 43: Dining room layout	37
Figure 2. 44: Functional layout for restaurant	38
Figure 2. 45: Fish Museum	39
Figure 2. 46: Laboratory Relationship Diagram	40
Figure 2. 47: Lab Module	40
Figure 2. 48: Lab Module	41
Figure 2. 49: Lab Module	42
Figure 2. 50: Space Utilization	42
Figure 2. 51: Laboratory and Laboratory Support Concept.....	42
Figure 2. 52: Laboratory Zones with Single Corridor	42
Figure 2. 53: Laboratory pod concept.....	43
Figure 2. 54: Single corridor (opt. 1)	47
Figure 2. 55: Single corridor (opt. 2)	47
Figure 2. 56: Double corridor (opt. 1).....	48
Figure 2. 57: Double corridor (opt. 2).....	48
Figure 2. 58: Lab with ghost corridor	48
Figure 2. 59: Shaft at the ends	48
Figure 2. 60: Multiple internal shafts.....	49
Figure 2. 61: Multiple exterior Shafts.....	49
Figure 2. 62: Service/Utility Corridor.....	50
Figure 2. 63: Lecture Hall.....	50
Figure 2. 64: Lecture Hall design standards	51
Figure 2. 65: Simplified diagram of Aquarium water system	53
Figure 2. 66: Closed water system.....	54
Figure 2. 67: Modern aquarium water system	55
Figure 2. 68: Nitrogen cycle in an aquarium	56
Figure 2. 69: Aquarium Plumbing	57
Figure 2. 70: Behind the scenes at Georgia Aquarium	57
Figure 2. 71: Sound Dampening Pad	60
Figure 2. 72: Sound Barrier	60
Figure 2. 73: Aquarium Filters as noise producers	60
Figure 2. 74: Gallery Space with proper lighting	61
Figure 2. 75: Lighting in Display area	61
Figure 2. 76: Top lighting	62
Figure 2. 77: Consideration for ramp.....	63
Figure 2. 78: Ramp gradients.....	64
Figure 2. 79: Parking Consideration	64
Figure 2. 80: Toilet design for special population	65
Figure 2. 81: Toilet design for special population	65
Figure 2. 82: Sink design for special population	65
Figure 2. 83: Turning for wheelchairs	65

Figure 2. 84: Staircase for universal design.....	66
Figure 2. 85: Considerations for step.....	66
Figure 3. 1: Central Zoo Masterplan.....	69
Figure 3. 2: Display tank Plan.....	69
Figure 3. 3: Elevation of Aquarium.....	70
Figure 3. 4: Display tanks.....	70
Figure 3. 5: Display tanks.....	70
Figure 3. 6: Filtration Plant.....	70
Figure 3. 7: Botanical garden Plan.....	71
Figure 3. 8: Bubble diagram of Botanical Garden.....	72
Figure 3. 9: Purpose of visit of people in Botanical Garden.....	72
Figure 3. 10: Entry to Information center.....	73
Figure 3. 11: Interior of Exhibition hall.....	73
Figure 3. 12: Plan of Exhibition hall.....	73
Figure 3. 13: Tropical House.....	73
Figure 3. 14: Plan and Elevation of Tropical house.....	74
Figure 3. 15: Coronation pond.....	74
Figure 3. 16: Aquatic garden near entrance.....	74
Figure 3. 17: Water supplied through canal.....	74
Figure 3. 18: Entry Gate.....	75
Figure 3. 19: Administration Block.....	75
Figure 3. 20: Research Tanks.....	75
Figure 3. 21: Research Laboratory.....	75
Figure 3. 22: Overall Area Division.....	76
Figure 3. 23: Masterplan of Fisheries Research Division.....	76
Figure 3. 24: Fish Museum.....	76
Figure 3. 25: Food production mill.....	76
Figure 3. 26: Taraporewala Aquarium.....	77
Figure 3. 27: Aquarium Location.....	78
Figure 3. 28: Masterplan with Zoning.....	78
Figure 3. 29: Display Gallery.....	79
Figure 3. 30: Aquarium Tunnel.....	79
Figure 3. 31: Lighting in Display area.....	80
Figure 3. 32: Water Circulation Diagram.....	80
Figure 3. 33: Monterey Bay Aquarium.....	81
Figure 3. 34: Ariel view of Monterey Bay Aquarium.....	82
Figure 3. 35: Site Location.....	82
Figure 3. 36: Masterplan of Monterey Bay Aquarium.....	83
Figure 3. 37: Section through Kelp forest.....	83
Figure 3. 38: Baby otter.....	84
Figure 3. 39: Outer Bay.....	84
Figure 3. 40: The Kelp Forest.....	84
Figure 3. 41: The Blue Planet.....	86
Figure 3. 42: Concept Development.....	87

Figure 3. 43: Whirlpool Concept	87
Figure 3. 44: Planning approach	87
Figure 3. 45: Sectional 3d view	88
Figure 3. 46: Masterplan of The blue Planet.....	88
Figure 3. 47: Aquarium Sections	88
Figure 3. 49: Display Gallery.....	89
Figure 3. 48: Display Gallery.....	89
Figure 3. 50: The Amazonia	89
Figure 4. 1: Site Location.....	94
Figure 4. 2: Fewa Lake seen from site	93
Figure 4. 3: Southern View	93
Figure 4. 4: Northern View from site.....	93
Figure 4. 5: N-E side view	93
Figure 4. 6: Western View from the site.....	93
Figure 4. 7: Eastern View from Site	93
Figure 4. 8: Site Analysis.....	93
Figure 4. 9: Climatic data.....	94
Figure 4. 10: Precipitation data.....	94
Figure 4. 11: Wind data	95
Figure 6. 1: Site with solar and wind path	104
Figure 6. 2: Zoning based on activities.....	104
Figure 6. 3: Axis and functions placement (Bubble diagram).....	105
Figure 6. 4: Functional Relationship Diagram.....	105
Figure 6. 5: Water ripple as concept	106
Figure 6. 6: Replicating Ocean in building.....	106
Figure 6. 7: Central Foyer space	106
Figure 6. 8: Planning approach	107
Figure 6. 9: Elevated walkways in Jungle Trail.....	107
Figure 6. 10: Entry and Landscape	108
Figure 6. 11: Admin block	108
Figure 6. 12: Aquarium Block A	109
Figure 6. 13: Jungle Trail.....	109
Figure 6. 14: Restaurant area	109
Figure 6. 15: Aquarium Block B.....	110
Figure 6. 16: Joint Block.....	110
Figure 6. 18: Circulation Diagram (Ground Floor)	110
Figure 6. 17: Circulation Diagram (Basement).....	110
Figure 6. 19: Ground Floor Area Analysis	111
Figure 6. 20: Basement Area Analysis	112
Figure 6. 21: First floor Area Analysis	113
Figure 6. 22: Second Floor Area Analysis.....	113

List of Tables

Table 1. 1: Research methodology adopted	6
Table 2. 1: List of Marine Plants	25
Table 2. 2: List of freshwater Plants	26
Table 2. 3: List of pond plants	27
Table 2. 4: List of freshwater species	28
Table 2. 5: List of Marine species.....	29
Table 2. 6: Space allocation	38
Table 2. 7: General Rules for planning Biomedical Laboratories	41
Table 2. 8: Space Schedule for Instrument Laboratories and Special Function	43
Table 2. 9: Space Schedule for Administrative, Interaction and Ancillary Space.....	46
Table 2. 10: Freshwater Aquarium water parameters.....	51
Table 2. 11: Marine Aquarium water Parameters.....	52
Table 2. 12: Relationship between slope of ramp and running length of landing	63
Table 2. 13: Clearance for wheelchair	65
Table 5. 1: Program formulation: Reception zone.....	97
Table 5. 2: Program formulation: Administration	97
Table 5. 3: Program formulation: Display Gallery	98
Table 5. 4: Program formulation: Life support & Maintainance	98
Table 5. 5: Program formulation: Services area	99
Table 5. 6: Program formulation: Storage	99
Table 5. 7: Program formulation: Restaurant	99
Table 5. 8: Program formulation: Education Center.....	100
Table 5. 9: Program formulation: Library.....	100
Table 5. 10: Program formulation: Multipurpose hall	101
Table 5. 11: Program formulation: Jungle Trail	101
Table 5. 12: Program formulation: Research Lab.....	102
Table 5. 13: Program formulation: Aquatic Lab.....	102
Table 5. 14: Program formulation: Lab Support.....	103
Table 5. 15: Program formulation: Cafe	103
Table 7. 1: Daily water consumption Calculation	115
Table 7. 2: Number of Users Calculation	116

1.0 Project Overview

The **Freshwater Aquarium and Research Center** is a facility that offers vocational training to maintain biodiversity by preserving and providing information about all varieties of aquatic plant and animal species.

A research facility that focuses on researching and protecting aquatic flora and animals with the goal of making people aware of their value. It consists of different spaces, **the research center** that studies about them, **Aquarium, or a display gallery** in which living aquatic animals or plants are kept and Rainforest Exhibit that showcases varieties of Native plants. The space with touching and interacting with the exhibit. A theater to show documentary or information regarding those life among people and the **classroom** so that they can give some training session. This project encourages learning about different species found underwater. The project has been established with a concept of “**conservation while having fun**”.

1.1 Introduction

The word "Aquarium" is made up of two words; "**Aquarius (Latin word)**" which means water and "**Vivarium(English word)**", which means container or box. Thus combining these aquarium simply means 'a box containing water'. This definition is not suitable in today's world as nowadays it is possible to artificially create habitats bigger than small natural lakes. From the outdoor ponds and glass jars of antiquity, modern aquariums have evolved into a wide range of specialized systems. Individual aquariums can vary in size from a small bowl large enough for only a single small fish, to the huge public aquarium that can simulate entire aquatic ecosystems. Thus the above definition is not suitable in today's world and the time has come where we stop seeing aquarium as a small glass box and should start seeing it as a journey to another world.



Figure 1. 1: Glass Pot Bowl (Fish Keeping), source: affectionpets.com

From a goldfish tank on the nightstand to large concrete tanks holding millions of gallons of water, the world has different varieties of aquariums now. Aquariums give us a rare opportunity to glance into aquatic life. With the advancement in technology, people can view almost any type of aquatic ecosystem or aquatic life indoors, without having to dive to an actual waterbody. Now, people don't have to get themselves wet in order to see the amazing underwater world. The advanced technologies like removal of ammonia and generating artificial seawater has boomed the aquarium industry to new heights. People can be several hundred miles away from the coastline and enjoy the sight of swimming dolphins as per their wish in their own time.



Figure 1. 2: Large Modern Aquarium, source: thembsgroup.co.uk

As the visitors number grows manifold, aquarium buildings have become one of the most interesting building forms for the 21st century architecture.

1.2 Overview in Global Context

The history of Public aquaria goes back to 19th century. The concept of display was series of rectangular, concrete tanks with glass fronts; Fishes and some invertebrates were placed in the tanks using taxonomic criteria as species taxonomy was then the “bible” among the biological sciences.

The first large public aquarium was opened in the London Zoo in 1853 and was known as the “Fish House”. The Berlin Public Aquarium was the second large aquarium that opened in Europe followed by the aquarium of Paris. Meanwhile the interest of the public in aquatic life showed an upward trend; the New York Aquarium Journal was first published in 1876 and was considered as the first aquarium magazine. The first Aquarist’s society in the United States was founded in New York in 1893 followed by many other societies on aquaria and aquatic life.



Figure 1. 3: Fish House, London Zoo, source: londonzoo.org

Nowadays there are many public aquaria in Europe, United States, Canada and the Far East. The serial rectangular tanks have been replaced by a few large tanks characterized by irregular geometry where various types of habitats are replicated promoting normal animal behavior (*Cains and Meritt, 1998*). Specimen introduction is based on the aquatic community concept highly influenced by aquatic community ecology concepts.

The development of aquaculture technology during the last three decades has provided to public aquaria a number of technical solutions, covering almost all aspects of aquarium construction, aquarium operation and fish husbandry (*Goertemiller, 1993*). Modern tank design and structure, new materials, advanced pumping technology, aeration systems, flow rate control, new systems for water abstraction and water treatment technology are among the “new weapons” in the hands of aquarium designers. Know how on disinfecting drinking water using ozonation and UV technology has also been transferred to aquaria and used as a routine practice. Mechanical filters used in swimming pools and aquaculture farms as well as purification methods based on biological treatment of the used water, have solved water quality problems in aquaria. In addition, operation practices such as water quality control, artificial lighting, use of chemical disinfectants, fish feeding techniques, fish pathology know how and reproductive success have greatly been benefited from aquaculture practices (*Landeau, 1992; Pillay and Kutty, 2005*)

1.3 Overview in Nepalese Context

Though Nepal is small, contains a disproportionately large diversity of plants and animals. It is fine collection of all kinds of plants and wildlife. The dramatic differences in elevation found in Nepal (60 m from sea level in the Terai plains, to 8,848.86 m Mount Everest) result in a variety of biomes. As the Eastern half of Nepal receives more rain compared to western parts so it is richer in biodiversity, where arctic desert-type conditions are more common at higher elevations. Therefore, the country has diverse climatic conditions over very short distances (south to north), due to influence of the altitudinal variations and its location in sub-tropical latitudes, which help to harbor high biodiversity.

The abundance of the flora and fauna of Nepal includes numerous species of mammals, birds, butterflies, Pisces, phonograms and many more species. Nepal is a habitat for 4.0% of all mammal species, 8.9% of bird species, 1.0% of reptile species, 2.5% of amphibian species, 1.9% of fish species, 3.7% of butterfly species, 0.5% of moth species and 0.4% of spider species. In its 35 forest types and 118 ecosystems, Nepal harbors 2% of the flowering plant species, 3% of pteridophytes and 6% of bryophytes.

Water too has been an important feature of landscape of Nepal. The relation of Nepalese people with water resources has always been close. We being landlocked country have always been away from the touch of sea/ocean. Only few people get to visit the seas and oceans on regular basis and maximum percentage of the population spend their life without ever being close to the sea/ocean. Thus, the topic of sea, oceans or the marine world has always been an elusive topic for us Nepalese.

Through Public aquarium we can spread the knowledge about freshwater world as well as marine water world. Its growing popularity and wide range of target population has made it one of the fastest rising public building projects in today's world.

1.4 Rationale of Project

Being landlocked, Nepal has only inland water resources including the river systems, lakes, reservoirs, village ponds, wetlands, and irrigated rice fields totaling 745,000 hectare of water surface area (*Amatya and Shrestha, 1967; Pradhan and Pantha, 1995*). The water bodies cover about 5% of the total area of the country. The lowland Terai is home to more than 100 species of fishes, with decreasing species richness as the altitude increases. The mid-hills region is the habitat for many sport fishes. The high mountainous region contains few species of small sized fishes. (*e Sharma, Chhatra M.(2008)*) We Nepalese pay a very little attention to fact that anything we do to the rivers ultimately affects the sea/ocean and the living things in it. Thus, in order to provide an education and a glimpse of aquatic world a freshwater aquarium might be a good project to start with.

Also, the lack of public aquariums in Nepal and the excuses that the landlocked country like Nepal can't have marine aquariums clearly shows its necessity. Due to advancement of modern technology, it has become possible to create a safe environment for aquatic animals in almost any place on Earth. Many landlocked country houses public aquariums which can be direct inspiration to all landlocked country including Nepal.

The aquatic life helps humans to sustain their life. It helps us breathe as phytoplankton-tiny plant like organisms that live in sea are responsible for at least 50% of oxygen on Earth. Aquatic body absorbs huge amount of heat from sun. According to the US National Oceanic and Atmospheric Administration "More than 90% of the warming that has happened on Earth over the past 50 years has occurred in ocean". So, it helps to regulate the climate. It is also an important source of food and has incredible biodiversity so must be protected.

To protect these animals' public aquarium might play an important role. Also, we Nepalese fish keepers know the names of imported fishes but don't know our own indigenous species. This project promotes the native species and increases awareness among the people and urge them to participate more actively in conservation program.

Providing knowledge to children, creating awareness among the public, research on aquatic life, conserving and promoting the indigenous an exotic fishes found in Nepal can be some important reasons why we need public aquarium in Nepal.

1.5 Importance of Research

- To learn what development has occurred in public aquarium design in terms of new requirements, planning, materials and technologies, sustainability, etc.
- To cover the history of public aquarium and providing a narrative on its relationship to the real world.
- To develop scientific attitude and thinking by encouraging curiosity and questioning process.
- To provide a permanent center for Research on aquatic life.
- To engage different age group of people in conservation of aquatic life.
- To attract and introduce people to Public Aquarium and its conservation.
- To establish a landmark dedicated to public aquarium in the country.

1.6 Aquarium Objectives

The first but more critical step when designing a public aquarium is a clear definition of the objectives of the aquarium: it must cover all aspects of aquarium activities that is visitor's recreation, research, education, and conservation or some of them.

(a) Recreational activities: The target group can be of different age groups. The visits can be combined with environmental awareness and the public will be educated by the “show and tell” practice common in public aquaria. The aquarium shall aim both individual visitors and families. It shall also aim at schools and various societies related to environmental aspects such as botany, zoology, natural history or aquarium societies. They shall have specialized facilities not available to the public such as tanks and research laboratories.

(b) Education: The main educational goals is to provide visitors necessary information about aquatic life conservation. It can have a kind of comprehensive guided tour. It is going to be both formal and informal education. Alternatively, the aquarium staff will be involved in more formal educational activities of pupils and students in collaboration with school authorities and universities in the form of seminars, summer schools, undergraduate teaching.

(c) Species and biodiversity conservation: Local endangered and rare species of flora and fauna can be conserved. This work can be carried out alone as well as in collaboration with concerned authority. (Karydis, 2011)

1.7 Research Objectives

The objective of the study was to gain knowledge about the varieties of definition, requirements, construction technology and overall design process that goes into designing and constructing a successful Freshwater aquarium for aquatic life conservation. As there is no any public aquariums in Nepal, this study is expected to aid any public aquarium designers in Nepal with necessary design standards, design components required for a public aquarium and various technological advances required in building a public aquarium. To know the various ways to conserve and protect the rare aquatic species to increase their numbers.

1.8 Research Methodology

Different phases of studies will be conducted for the purpose of this thesis, to formulate the program and spaces required. The methodologies and procedures to be used are literature review, case study, and design idea formulation and planning. This procedure entails identifying the project location, conducting a case study of similar projects to determine the building situation, and developing a design program. A design concept will be generated based on the literature review, case study, and research.

PHASE 1	PHASE 2	PHASE 3
Basic research of Topic	Site Visit	Research for further design
Relations with architecture and its importance	Primary data and secondary data collections	Program Formulation
Objective Analysis and understanding	Case studies both national and International	Concept Development
Literature review	Self-Evaluation & Analysis	Design

Table 1. 1: Research methodology adopted.

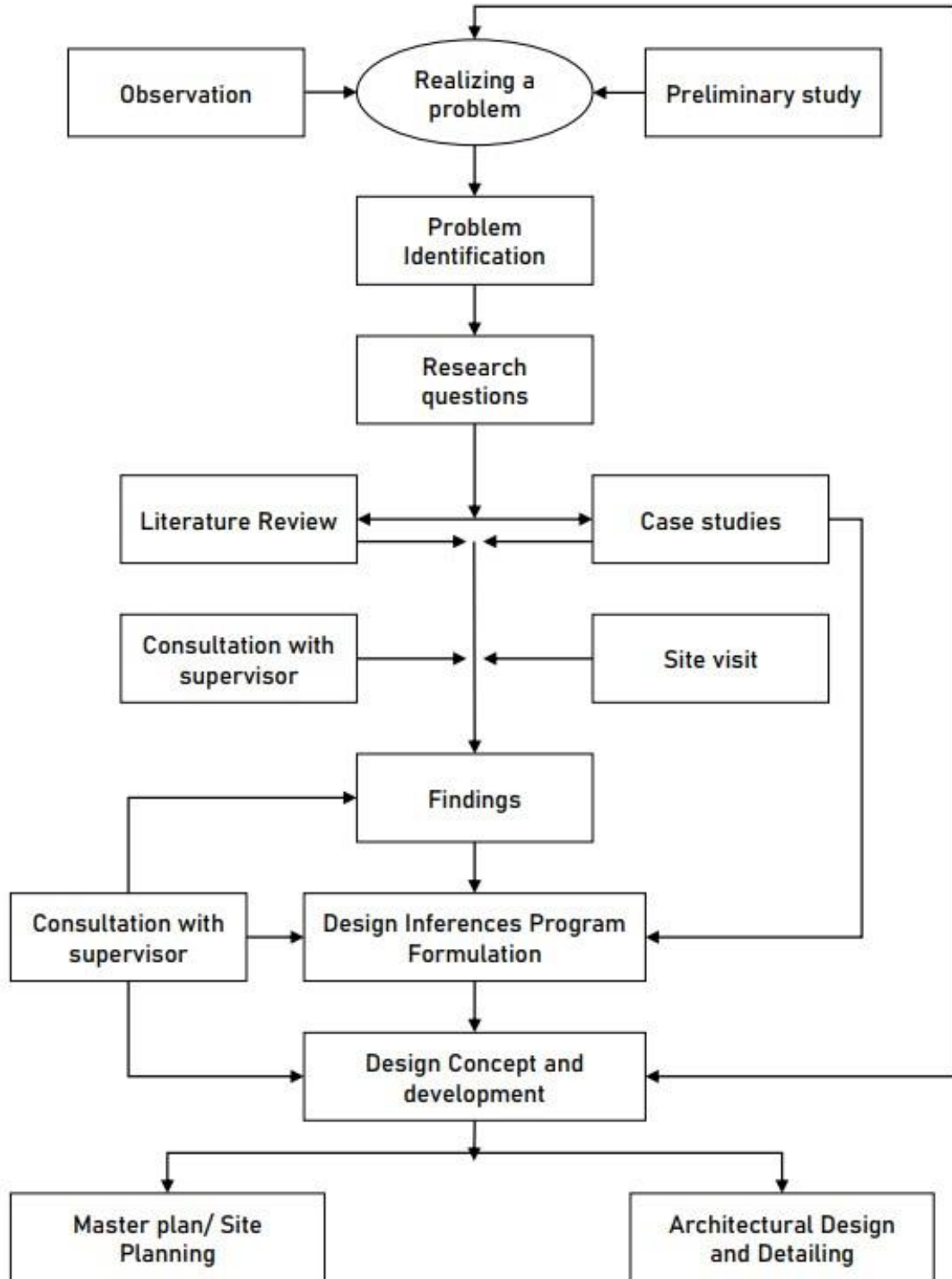

Figure 1. 4: Methodology of Project

2.0 Literature Review

2.1 Public Aquarium

A public aquarium is the aquatic counterpart of a zoo, which houses living aquatic animal and plant specimens for public viewing. Public aquarium are facilities open to the public for viewing of aquatic species in aquaria. Most public aquaria feature several smaller tanks, as well as one or more tanks greater in size than could be kept by any home aquarist. The largest tanks hold many liters of water and can house large species. Aquatic, semiaquatic animals as well as amphibians may also be kept by public aquaria.



Figure 2. 1: Public Aquarium, source: pinterest.com

Operationally, a public aquarium is similar in many ways to a zoo or museum. A good aquarium will have special exhibits to entice repeat visitors, in addition to its permanent collection. A few have their own version of a "petting zoo"; for instance, the Monterey Bay Aquarium has a shallow tank filled with common types of rays, and one can reach in to feel their leathery skins as they pass by. Large Public aquariums have become fixtures in most major urban regions. In some places, they have become among the leading attractions for city tourism, where many aquariums have also expanded into conservation efforts and applied research along with being tourist destinations.

Freshwater fishes are also displayed in public aquariums worldwide, admired at home by hobbyists, fished for by anglers, portrayed extensively in art and cultural artefacts, and everywhere exploited in large quantities for human food, animal fodder and other products. Despite this, there is only a limited political, public, and curatorial awareness of major global challenges that directly or indirectly threaten the survival of the entire cohort of fishes in the wild. Freshwater fishes may now be the most threatened group of vertebrates or chordates, based on the > 5000 species (< 40% of total) so far assessed by the International Union for Conservation of Nature (IUCN). Fishes can be included in a broader informal category of 'water-dependent taxa' containing many other threatened species of plants, invertebrates, amphibians, reptiles, birds and mammals, some of which are kept in zoos and aquariums (IUCN, undated). In the wild, these plants and animals are ecologically interdependent.

2.1.1 History of Public Aquariums

Artificial fishponds were likely the first type of aquarium in antiquity. In ancient Mesopotamia and Egypt, fish were likely placed in artificial ponds, as most cities were located along rivers and fish likely served as sources of food but possibly also amusement. It is possible that sacred fish were kept in temples not so much as pets but rather as symbols or embodiment of fish gods. For instance, the god Dagon, mentioned in the Bible, was often depicted as a fish god. The Egyptian goddess Hatmehit, similarly, may have had fish represented with her. In Egyptian

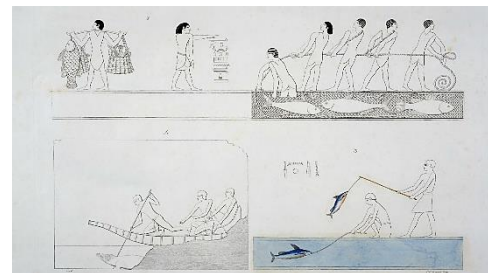

Figure 2. 2: Artificial Fishponds, Egyptian Period, source: newarab.com

reliefs, fish have been displayed as being placed in artificial environments, including ponds or lakes created in gardens or specific places. (Kisling, 2001)

Perhaps China is the best-known early culture for developing what became fish pets. China, for over 2000 years, has known to have bred carp for their color and beauty, what we call today as goldfish (Figure 1). The koi, a type of carp perhaps originally from Iran and Central Asia, was likely imported to China and over centuries developed the variety of colors we see in many types of goldfish today. The Jing dynasty (265-420 CE) was the first to record the process of raising goldfish for their color and raising as ornamental fish. While initially the carp may have been raised for food, it was noticed that sometimes fish naturally produced colors such as orange or red as a type of mutation. This led to these fish being bred for their colors in royal settings and estates of the wealthy. The raising of goldfish soon became a source of pride for royal Chinese figures and officials, where goldfish varieties were even raised indoors, enabling some types that would normally die easily in an outdoor environment to thrive and adapt better to the indoors. (Richardo Calado, 2017)

The Romans may have been the first to put glass in their indoor aquariums. Sea fish were popular for food in ancient Rome, where archaeological remains suggest that the Romans may have even constructed their ships to transport live fish through tanks contained within the vessels that would suction in sea water. This taste for live fish may have prompted development of aquarium tanks. At first, Romans seemed to have used marble to keep sea fish in. Later, as glass technologies improved and became more durable, the Romans, by the 1st century CE, began to use glass in tanks. This allowed those wanting to eat fish to view what they were getting more easily. Romans did likely keep fish as pets as well in ornamental ponds. In fact, they may have been the first to keep saltwater fish as pets. However, it seems most fish tanks were likely used for keeping fish to eat. (Aquarium Fish Magazines, 1996)

2.1.2 Development of Public Aquarium

Where fish tanks did exist, they were mostly for private use in the ancient world. Fishponds did, however, become more public spaces in Medieval Europe, as cities and towns developed these as places to store fish for food and raise them as a type of fish farm. In the 17th century, goldfish were introduced to Europe, which, for the first time, brought a type of fish that exclusively was bred for its looks rather than taste. With the development of palatial gardens, goldfish, countries like China and Japan, began to raise them as ornamental animals. (Adamson, 2004)

While interest in ornamental fish increased in Europe with greater access to wealth and contacts with China, the main development that made public aquariums took time to develop. The major development was the innovation of the Wardian case, which was a type of glass container used to house plants initially so that they can be studied and observed. Although this development by Jeanne Villepreux-Power in 1832 was made for the study of plants, it was soon realized that live fish could be contained within these glass enclosures along with the plants for long periods. Soon after, others began to experiment with a variety of fish species, where they were placed in tanks to see how they would respond. It was evident to scientists that plants that lived in water provided oxygen that fish could use, allowing many types of fish to be kept indefinitely so long as the number of plants was sufficient for the number of fish.

Mostly, until about the 1850s, fish keeping in aquariums was the privy of scientists or those wealthy enough to have such interests. Things changed after the Great Exhibition in London in 1851. The first large public aquarium was built at the London Zoo (in 1853) in Regents Park, where the tanks were mostly metal-framed structures created by Phillip Gosse, who used the term aquarium for the first time. The so-called "Fish House" in the London Zoo pioneered the use of a series of fish tank containers along the walls and other exhibits in the main floor of a dedicated building to fish, which now provided the model for other zoos and dedicated aquariums to emulate. Now it became fashionable to collect exotic and strange species for public display, particularly as public curiosity fueled interest. By the 1850s and 1860s, other cities in Europe, such as Paris, and North America began to build large public aquariums. (Kisling, 2001)

While glass containers improved and were getting larger by the late 19th century, particularly as more major cities in Europe and North America began to build aquariums, the general approach to keeping fish did not change much during the late 19th century. It was only in the early 1900s that more innovations made it possible to dispense with plants all together. Since the 1830s, the "balanced aquarium" approach of keeping fish meant that you could only have a given number of fish in a tank based on the number of plants you had. Charcoal-based filtration and mechanical air pumps were invented to allow oxygen to be pumped into tanks as a replacement for plants; this soon became the primary way in which tanks kept fish throughout the early 20th century, although plants were often retained for their ornamental qualities. (Delbeek, 2005)

In the 1950s, the under-gravel filter was introduced, which was a way to pump air through the base of the tanks (or the gravel acting as the base of the aquarium). From the 1950s and into the 1970s, more varieties of fish were also introduced at aquariums to further rise the interest of the public. During the 1960s, dolphinariums were developed in North America first and then later Europe, where this proved to be very popular in drawing larger crowds to aquariums and what soon developed as larger private safari and other parks. The 1960s also saw the development of new sealant technologies that allowed glass only rather than glass and metal aquariums to be developed. (Hemdal, 2003)

Filters continued to be improved, including the wet-dry filter in the 1980s, that allowed more exotic corals to be kept more easily. With the environmental movements of the 1970s, aquariums, similar to zoos, increasingly began to focus towards conservation efforts. Other major aquariums, such as the National Aquarium in Baltimore, have largely re-branded themselves as research and conservation facilities, although public display helps to fund their activities and educate the public. (Helfman, 2007)

2.1.3 Public Aquariums Today

Modern aquarium tanks can hold millions of liters of water and can house large species, including dolphins, sharks or beluga whales. This is accomplished through thick, clear acrylic glass windows. Aquatic and semiaquatic mammals, including otters and seals are often cared for at aquariums. Some establishments, such as the Oregon Coast Aquarium or the Monterey Bay Aquarium, have aquatic aviaries. Modern aquariums also include land animals and plants that spend time in or near the water. (Taylor, 1993)

For marketing purposes, many aquariums promote special exhibits, in addition to their permanent collections. Some have aquatic versions of a petting zoo. The Monterey Bay Aquarium has a shallow tank filled with common types of rays which visitors are encouraged to touch. The South Carolina Aquarium lets visitors feed the rays in their Saltmarsh Aviary exhibit. (scaquarium.org, 2011)

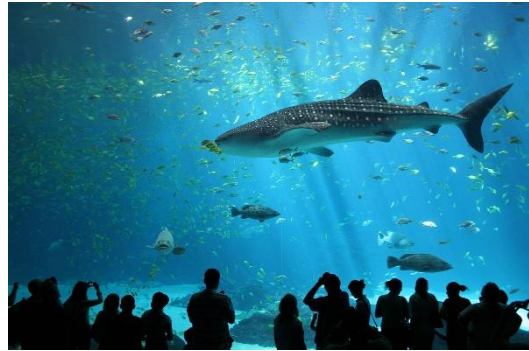

Figure 2. 3: Whale shark in Georgia Aquarium's largest aquarium

The largest public aquarium is the Chimelong Ocean Kingdom theme park, opened in 2014 in Hengqin, Zhuhai, with a total of 48.75 million liters (12.87 million US gal) of water. The second largest is the Marine Life Park in southern Singapore with a total of 45 million liters (12 million US gal) of water for more than 100,000 marine animals of over 800 species. (scaquarium.org, 2011)

2.1.4 Benefits of Public Aquarium:

1. Animal rescue, care, and rehabilitation

Many new aquariums feature dedicated animal rescue and care facilities from day one. In recent years, as the industry evolves and expands its remit, older aquariums have added rescue and rehab services too. Unsurprisingly, rescue and rehabilitation resources must match the species found locally. Since animal populations vary from place to place, new aquarium designers should consult with experts when considering which animal-care facilities are most likely to be needed.



Figure 2. 4: Sea turtle rescue, source: advanced-aquariums.com

2. Scientific research

Researching wild animals in their natural habitats is ideal. However, in the case of aquatic species, field-studies can be too expensive, impractical, or even impossible. Scientists increasingly recognize that aquariums provide straight forward access to living species for meaningful research projects that, in turn, aid animal health, wellbeing and conservation. Many aquariums fund or participate in collaborative research programs or make facilities available to independent researchers from accredited institutions such as universities.



Figure 2. 5: Research Setup, source: advanced-aquariums.com

Indeed, aquariums increasingly give research a prominent role in their mission statements.

In their book, *Scientific Foundations of Zoos and Aquariums: Their Role in Conservation and Research* (2019), the authors highlight a wide range of study areas for zoos and aquariums including but not limited to anatomy and physiology, cognitive ability and behavior, disease, pathology, veterinary care, mortality, growth and development, nutrition, diet, breeding and reintroduction. Many of these topics play a direct role in supporting conservation.

3. Conservation and education

Urbanization and modern lifestyles limit our access to natural habitats, where we can observe and experience wild flora and fauna. Society is disconnecting from nature. Aquariums can help. More than merely animal viewing areas, aquarium exhibits simulate the aesthetics, features, and functionality of natural habitats. Phenomenal attention to detail in exhibit design and modern construction techniques is not just for show – it supports the health and wellbeing of the animals. While nothing beats the real thing, a trip to an aquarium reminds us of the beauty – and fragility – of nature. By reawakening the bond with natural habitats, people are more motivated to support conservation, such as by reducing the use of plastics that pollute oceans and destroy marine life.



Figure 2. 6: Educating Kids with the help of games, source: advanced-aquariums.com

Beyond support for scientific research projects, aquariums' most significant contribution to conservation is the sheer number of people passing through them. Touched by what they saw and experienced, many visitors resolve to support natural habitats more actively, afterwards. Aquariums provide many opportunities for formal educational services too. With the perfect combination of excitement, drama and structured educational content, aquariums make outstanding daytrips for school children of all ages. Members of the British and Irish Association of Zoos and Aquariums (BIAZA) – which represents over 100 zoos and aquariums – hosted 1.2 million educational visits in 2019. Large acrylic tunnels and dramatic architecture create inspiring and attractive event spaces for conservation experts to provide informative talks to fee-paying adults, too.

4. Leisure and entertainment

Everyone needs some fun, especially families with children. That is why aquariums are installing more and more of the digital, creative, and immersive experiences that modern visitors love. These include Partially submerged viewing and feeding platforms with unprecedented views of large animals swimming around the main tank, such as at the Dubai Mall Aquarium. Scuba-diving opportunities, including courses with qualified trainers.



Figure 2. 7: Touch Tank, source: icm

Ever richer digital-interactive displays Breathtaking theme-designs and creative experiences Swimcages that give thrill-seekers a chance to get up-close-and-personal, safely, with crocodiles and other threatening species 50% of adults visiting an aquarium are accompanied by a child, according to AZA. Innovative, fun-filled experiences add excitement and action to their trip. In turn, these experiences increase the value aquariums deliver to local communities and tourists looking for constructive and fun things-to-do.

5. Tourist attraction

With their unique combination of scale, architecture, exhibits and experiences, aquariums attract tourists to cities and keep them there longer. Nearly 90 percent of visitors to The National Aquarium, about 65 km North-East of Washington DC, report that the aquarium is their primary reason for visiting Baltimore. It typically attracts more than 1.3 million visitors each year. The World Association of Zoos and Aquariums (WAZA) – which represents nearly 400 leading institutions and organizations from more than 50 countries that Zoos and Aquariums attract some 700 million visitors annually.



Figure 2. 8: Tourists in Public Aquarium, source: advanced-aquariums.com

Baltimore's situation may be an extreme version of the popularity of aquariums. In other destinations, a new aquarium might round out, update and strengthen a broad portfolio of existing attractions, igniting a new wave of interest in visiting. A gorgeous new aquarium could be the cherry on top of the cake.

6. Urban renewal

Many cities have run-down neighborhoods and derelict land such as abandoned industrial areas that came out on the wrong side of change long ago. Aquariums have a significant physical footprint and wide-reaching economic impact. It's a match made in heaven.

The World Association of Zoos and Aquariums (WAZA)...estimates that Zoos and Aquariums attract some 700 million visitors annually.



Figure 2. 9: Antalya Aquarium, Turkey, source: advanced-aquariums.com

Urban areas in need of rehabilitation with good access to transportation corridors can make excellent candidates for a new aquarium feasibility study. If validated, building an aquarium could transform ugly sore spots into spectacular, award-winning architecture and create dozens or even hundreds of jobs in the area.

7. Economic development

Aquariums produce direct and indirect forms of economic activity. The direct economic activity includes the money that aquariums spend on the goods and services they need. The indirect economic activity includes the positive impact that an aquarium has on other

businesses – such as hotels, restaurants, and shops nearby. Economic activity also raises extra taxes for Cities and States too. (advanced-aquariums.com, 2020)

2.2 General Planning Guidelines:

The concept of the Aquarium, what it will be and do, must be determined early in the inception phase of the project. Within the funds available, what usual and what special features will be included must be decided upon. (Chira, 1983)

An initial Simple design should be prepared which presumably will provide adequate space for the expected visitors and will also provide the necessary operating areas. These must then be considered with knowledgeable persons and be modified as required. If aquarium is to be more than a house for living aquatic animals and plants, an exhibit specialist should be at hand to design presentations to meet the objectives of the institutions. (Chira, 1983)

2.2.1 Considerations from the Planning perspective:

Aquariums and zoos large and small have in the past been places established to showcase animals as entertaining curiosities, with varying degrees of concern about the physical or psychological well-being of the animals themselves. That approach is undergoing a seismic shift in response to many individuals and organizations insisting that animals in captivity—and in the wild- be treated with greater dignity, respect, and protection from human harm. In 21st century Public Aquarium are leaning more towards ‘Educational recreation’ for the visitors. Research along with experience sharing among experts as well as visitors have shown that a mere lineup of tanks containing specimens identified by photographs, names and range may be interesting, but not sufficiently informative. Grouping of specimens may be made to illustrate environmental preferences, means of locomotion, sight, hearing, schooling, and any other interesting and informative themes. If this information is included, then the visitors will absorb much knowledge of aquatic life. Then particular configurations of tanks, in separated groups, in such a way that the theme can be effectively carried out to the audience should be included by the planners.

The funding parties of project must be clear that only 2/5th of the built area can be accessible to public, and the remaining area shall be consumed by other functions such as maintenance and operational areas which is outside of public reach. Also at least 60% of cost will be for facilities, equipment and designs which are important to aquariums but are not visible to the public. (Chira, 1983)

The start of the 21st century has proved to be a challenging time for aquariums and zoos, certainly in North America and Europe. There was increasing evidence to show that a wide range of animal species, not just so-called ‘higher’ vertebrates, are, in fact, sentient creatures, able to suffer pain and feel emotions. They have lives beyond, and far more complex than, the hard-wired automatons that they were just a few years previously. With renewed vigor, proponents of animal rights and anti-captivity extremists questioned the need for aquariums and zoos, questioned their underlying motives, and questioned whether they were achieving all the impacts that they claimed. The widely publicized film Blackfish captured the zeitgeist of the time, and aquariums and zoos were forced to reflect on their achievements, against a background of disturbing and increasing biodiversity loss, the Sixth Mass Extinction, and disappointing results from some of the vaunted captive breeding programs of the previous 40

years or so. All of this at a time when aquarium displays had effectively stagnated, with no significant novel display ideas for many years (noting that bigger was no longer novel or even newsworthy). Indeed, some became jaded about aquarium offerings, aware that they were now able to experience the world on a computer, a high-definition TV, a handheld device, or a VR headset, all without leaving their home. The Age of Man had arrived.

2.3 Space Classification in a public Aquarium:

Building design should consider several points. There should be a rather large lobby for receiving the visitors; it is a usual practice for public aquaria to receive groups of people: school classes, groups of tourists, visits from universities and visits organized by societies. The entry to the aquarium display should be slightly delayed for the adaptation of the visitors to the dim light of the surroundings. Information referring to the exhibits and aquarium activities in the form of posters or power point projections can keep the visitors occupied while they proceed slowly to the tank display area. The whole way should be flat for safety reasons. (Karydis, 2011)



Figure 2. 10: Interior of Public aquarium, source: artstation.com

The display area should be viewed on the “one way” pattern and the exit should lead, if possible, to a small museum or exhibition place providing additional information mainly through preserved specimens and panels, posters, and computer programs. This supplementary information will also prolong the time spent in the aquarium building. Eventually the visit should lead to an aquarium shop near the exit. Visitors should not have any access to aquarium installation, laboratories or other ancillary



Figure 2. 11: Display Area of Public Aquarium, source: thehindu.com

facilities unless a specific visit has been arranged, programmed thoroughly and all safety measures have been taken. Space requirements for pumping facilities, the master tank, the control room, laboratories, storage place, tanks for fish quarantines and tanks for the reserve fish stock must be considered. In addition, a small lecture theatre and a reading room are necessary for research and educational activities. Research laboratories in addition to the laboratories designed for the operation of the aquarium are needed if research activities are among the aquarium objectives. Categorizing the spaces according to the function is essential if the aquarium is to run smoothly and be successful. (Karydis, 2011)

The nature of spaces within public aquariums may vary depending upon the size of facility and concept of design. So, categorizing these spaces according to the functions included is essential to run aquarium smoothly.

2.3.1 Exhibition Galleries

These are the spaces where visitors might roam about freely to view the display tanks and the wildlife within them. Exhibition areas are supposed to be designed in an interactive way, so that the visitor feels a need to be involved. The design regulation for exhibition areas mostly

depends upon the anthropometry of the visitors, circulation pattern of the exhibits, placement pattern of the tanks, lighting of the exhibition halls and ease of access to and from the exhibits.

A. Tanks

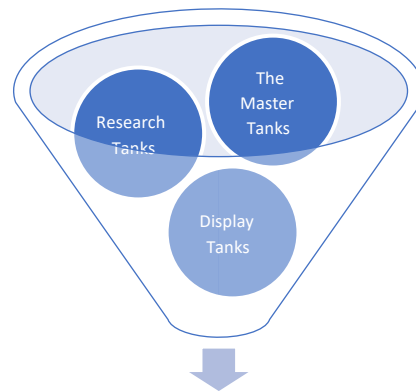

The Master Tanks:

A master tank (also known as the head tank) is a necessary component of every aquarium water system as it serves several functions. The master tank being the general distributor of the system is placed higher than the display tanks and the tanks for research to provide gravity flow. This way it functions as a transition zone between pump supply and demand, smoothing out any irregularities in water demand. Irregular demand may be due to cleaning or refilling procedures. Irregular supply may be due to pump failure, pump service, pipeline servicing or provisionally unsuitable water quality due to storms (intense resuspension of the sediment). If the residence time is more than an hour the head tank can act as sedimentation chamber. However, master tanks cannot act as temperature regulators. The high specific heat capacity of the water in combination with the limited residence time does not allow temperature conditioning. It is advisable that master tanks must be roomy as well as easily and safely accessible by the staff for installing and servicing heating elements, filters, meters, and other pieces of equipment.

Research Tanks:

A basic requirement in research is flexibility on the size, number, and tank arrangement according to the experimental design. Research tanks can be made of glass, fiberglass, plywood embedded with epoxy resins, stainless steel, or PVC. It is important that the surfaces will not be toxic, and cleaning of the surfaces will be easy. They are usually of rectangular shape as they do not take up too much space and they are easy to handle. The laboratory where the tanks are kept should have water and draining facilities at regular intervals so that



Figure 2. 12: Research Tanks, source: toddfishtech.com

different tank arrangements can be easily set under working conditions. It is advisable that their depth should not exceed 60 or 70 cm so they can easily be handled inside. If special care should be taken about the fishes, then round tanks seem to be the best solution. This way fishes will not be injured, and circulation can be easily induced. Elongated tanks known as raceways are required if fish need to swim for a long time possibly against a water flow. Raceways can be

built either from plywood or fiberglass panels. Due to their length, they need external or internal bracing.

Display Tanks

Display Tanks are the heart of the exhibition of any aquarium. Properly and expertly designed aquarium tanks can be as entertaining as they are educative. Housing necessary exhibits along with proper aquascaping, tanks are designed to replicate the natural habitat as much as possible so that the residing species may achieve maximum comfort in this artificial habitat. Tanks for the display of aquatic specimens are expensive. Materials in tanks for seawater must be more carefully chosen than for fresh water. Nevertheless, all tanks should be made of inert material greatest extent possible.



Figure 2. 13: Display Tank, source: made-in-china.com

Ideal tanks are those that are least costly, light in weight, readily altered or drilled. inert in seawater, with hard and smooth interiors, among other things. No currently available materials from which tanks may be produced have quite all the foregoing desirable features. For smaller tanks (up to about 2,000 gal), fiber glass or plastic-impregnated plywood appear to be quite satisfactory.

Several companies manufacture fiber glass aquaria or holding tanks. Moreover, some of these will fabricate to specifications. It is desirable to plan to install tanks of standard sizes, preferably those that are available "off the shelf" or for which fiber glass-fabricating forms are still available. Fiber glass is completely inert, is light in weight, and can be readily altered and drilled. Some experience by aquarium personnel will permit them to make repairs. It is quite possible, with an experienced technician, for an aquarium to fabricate its own tanks of reinforced fiber glass. For larger tanks, reinforced concrete, steel plate, or some other substantial and suitable material will be required.

Concrete tanks should never be poured as an integral part of the building. Each such tank should be an independent unit, capable of being broken up and removed without damage to the building. The design of tanks should consider the problems of drainage, cleaning, viewing, etc. Some tanks, because of the specimens to be held therein, may require special features, e.g., scuppers at the surface to remove oily film produced by some foods. Rapid drainage is desirable. It is preferable that gravel or sand does not touch the viewing glass. Disappearing side walls may be desired.

All concrete and metal surfaces should be coated with an epoxy sealer. This will continue to seal the inevitable hairline cracks in concrete, and thus prevent seawater (particularly) from attacking the reinforcing iron. (If possible, Monel bars should be used.) The seal also inhibits the growth of algae. Color may be added to the epoxy. Epoxy may also be used with sand to provide skid proofing for wet floors, ramps, etc. Careful application of epoxy paints over concrete will prevent blistering. (Chira, 1983)

B. Types of Display tanks in an aquarium

a) Based on salinity:

One of the most basic ways to classify aquaria is their salinity. Freshwater aquaria are the most popular kind of aquarium due to their lower cost and ease of maintenance. Marine aquaria generally require more complex equipment to set up and maintain than freshwater aquaria. Along with fish species, marine aquaria frequently feature a diverse range of invertebrates. Brackish water aquaria combine elements of both marine and freshwater fish keeping. Fish kept in brackish water aquaria generally come from habitats with varying salinity, such as mangroves and estuaries. Certain subtypes of aquaria also exist within these types, such as the reef aquarium, a type of marine aquarium that houses coral. (Tamrakar, 2012)



Figure 2. 14: Saltwater Aquarium, source: oceanfloorstore.com

b). Based on temperature range

Another method to classify aquaria is their temperature range. Most aquarists maintain a tropical aquarium as these fish tend to be more colorful. However, the Coldwater aquarium is also popular, which often includes fish such as goldfish. (Tamrakar, 2012)



Figure 2. 15: Tropical aquarium, source: youtube.com

c). Based on species selection

Aquaria may be grouped by their species selection. The community tank is the most common type of aquarium kept today, where several non-aggressive species are housed peacefully together. Aggressive tanks, in contrast, house a limited number of species that can be aggressive toward other fish, or are able to withstand aggression well. Species or specimen tanks usually only house one fish species, along with plants, perhaps found in the fishes' natural environment and decorations simulating a true ecosystem. This type is useful for fish that simply cannot be housed safely with other fish, such as the electric eel, as an extreme example. Some tanks of this sort are used simply to house adults for breeding. In these aquaria, the aquarium fish, invertebrates, and plants may or may not originate from the same geographic region, but generally tolerate similar water conditions. (Tamrakar, 2012)

	Malawian Cichlids	Tanganyikan Cichlids	Misc. African Cichlids	New World Cichlids	Angelfish	Barbs	Bettas	Cory Cats	Danios / Minnows	Discus	Fancy Goldfish	Gouramis	Guppies	Hatchets	Killifish	Larger Catfish	Loaches	Mollies	Platies	Plecos	Rainbowfish	Rasboras	Sharks	Suckermouth Catfish	Swordtails	Tetras	Misc. Fish	Invertebrates	Brackish Fish	Pond Fish	Freshwater Plants
Malawian Cichlids	Y																														
Tanganyikan Cichlids	C	C																													
Misc. African Cichlids	C	C	Y																												
New World Cichlids	C	C	C	C																											
Angelfish	N	N	N	C	Y																										
Barbs	C	C	C	C	C	Y																									
Bettas	N	N	N	N	C	N	C																								
Cory Cats	C	C	C	C	Y	Y	Y	Y																							
Danios / Minnows	N	N	N	C	Y	Y	Y	Y	Y																						
Discus	N	N	N	C	C	C	C	Y	Y																						
Fancy Goldfish	N	N	N	N	N	N	Y	N	N	Y	N	Y																			
Gouramis	N	N	N	C	Y	Y	C	Y	Y	C	N	Y																			
Guppies	N	N	N	N	Y	C	Y	Y	Y	Y	N	Y	Y																		
Hatchets	N	N	N	C	Y	C	Y	Y	Y	Y	N	Y	Y	Y																	
Killifish	N	N	N	C	Y	C	C	Y	Y	Y	N	Y	Y	Y																	
Larger Catfish	C	C	C	C	C	C	C	C	C	C	N	C	C	C	C																
Loaches	C	C	C	C	Y	Y	Y	Y	Y	Y	C	Y	C	Y	C	C															
Mollies	N	N	N	C	Y	Y	Y	Y	Y	Y	N	Y	Y	Y	C	C	Y														
Platies	N	N	N	C	Y	C	Y	Y	Y	Y	N	Y	Y	Y	C	C	Y	Y													
Plecos	Y	Y	Y	Y	Y	Y	Y	Y	Y	C	Y	Y	Y	Y	C	Y	Y	Y	C												
Rainbowfish	N	N	N	C	Y	Y	C	Y	Y	Y	N	Y	Y	C	Y	Y	Y	Y	Y	Y											
Rasboras	N	N	N	C	Y	Y	Y	Y	Y	Y	N	Y	Y	Y	C	Y	Y	Y	Y	Y	Y										
Sharks	C	C	C	C	Y	C	C	Y	C	N	Y	C	C	C	C	Y	C	C	Y	Y	C	C									
Suckermouth Catfish	C	C	C	C	Y	Y	Y	Y	C	Y	Y	C	Y	Y	C	Y	C	Y	C	Y	Y	Y	C	Y							
Swordtails	N	N	N	C	Y	C	Y	Y	Y	Y	N	Y	Y	Y	C	Y	Y	Y	Y	Y	Y	C	Y	Y	Y	C	Y				
Tetras	N	N	N	C	Y	Y	Y	Y	Y	Y	N	C	Y	Y	N	Y	Y	Y	Y	Y	Y	Y	C	Y	Y	Y	Y				
Misc. Fish	C	C	C	C	C	C	C	C	C	C	C	C	C	C	C	C	C	C	C	C	C	C	C	C	C	C	C	C	C	C	C
Invertebrates	C	C	C	C	C	C	C	C	C	C	C	C	C	C	C	C	C	C	C	C	C	C	C	C	C	C	C	C	C	C	C
Brackish Fish	N	N	N	C	N	C	N	N	C	N	N	N	N	N	C	C	Y	N	C	N	C	N	C	N	N	C	N	C	Y		
Pond Fish	N	N	N	N	N	N	N	N	N	Y	N	N	N	N	N	N	N	N	N	N	N	N	N	N	N	N	N	N	C	N	Y
Freshwater Plants	C	C	C	C	Y	Y	Y	Y	Y	Y	C	Y	Y	Y	C	Y	Y	Y	C	Y	Y	Y	C	Y	Y	C	Y	C	Y	C	Y

Figure 2. 16: Freshwater & Brackish water fishes compatibility chart, source: liveaquaria.com

d). Based on Design and Construction:

An aquarium tank may also be classed based on its design and construction materials. In a residential scale aquarium, Regular plastic or glass tank are used which are easily capable of holding about 1000 gallons of water or more if constructed with special need in mind. These tanks are simple to maintain, light in weight, and convenient to transport from one location to another if necessary. Reinforced concrete tanks are used in public aquariums where a large volume of water must be retained within a tank (for example, shark tanks, huge community tanks, ocean tanks, coral reef tanks, kelp forest tanks, and so on). An acrylic window or viewport is constructed and placed in one or more of the tanks so that visitors may see inside.

Special shapes of concrete and plastic tanks should be designed and placed in the aquarium for a variety of reasons, including fine tuning the circulation layout of the aquarium floor at the corners, breaking the monotony created by the same type of tanks, making a tank stand out among other tanks, facilitating the streamline movement of the fishes within the tank, and so on. Special curvilinear tanks are specifically developed and installed in the aquarium floor itself in this scenario. (Tamrakar, 2012)

Other types of show tanks include the following.

Vanishing wall Tanks:

These tanks might be made of concrete or acrylic, with side walls that taper away from the viewing side. It uses the idea of light refraction to prevent spectators from seeing the tanks' side walls. This improves the watching experience because visitors can only see water via the viewing panel. This gives the impression of a wider area within the tank, with no visible barriers. Typically, the walls are positioned at a 43-degree angle to the vertical. This critical angle is the maximum angle permissible to prevent the specimens from retreating from the visitor's sight of the viewer and minimum angle required to eliminate the side walls from the line of sight when looking through the viewing panel.

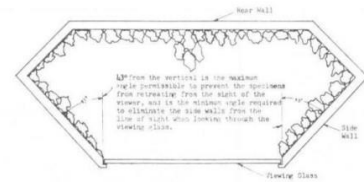

Figure 2.17: Vanishing Wall Tank, source: Time-Saver Standards

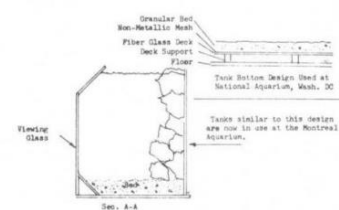

Figure 2.18: Typical Vanishing Side wall tank, source: Time-Saver Standards

Touch tanks/ Petting tanks

Touch tanks, often known as petting zoos, are shallow, open-floor tanks that are uncovered at the top and only a foot or two high. They are intended for interaction with guests. Non-aggressive species such as rays and clown fish are housed in these aquariums. Visitors can engage with these species by gently touching or petting the displays with their hands. This sort of tank is quite popular, particularly among youngsters.



Figure 2.19: Touch Tank, source: blogspot.com

Tunnel within the tanks:

A tunnel is a void within a larger tank, not a tank in and of itself. This area is utilized in big tanks if seeing from the outside is insufficient and visitors need to get closer to the specimens to get the full experience. Tunnels are often cylindrical or circular in shape. The most frequent style of tunnel has a fixed radius and extends 180 meters. These tunnels can be faceted to allow for turns within the tank. In an ideal tunnel, the viewer is fully enclosed by water at some point, such that they can only see water in whichever direction they look. A tunnel design can, and frequently does, extend beyond 1800 feet to offer the observer with a panoramic view of the tank's interior.



Figure 2.20: Acrylic Aquarium Tank Tunnel, source: arch2o.com

Cylindrical Aquarium Tunnel

Tunnels are typically cylindrical in design. The most common tunnel has a constant radius and spans 180°. These tunnels can be faceted to make turns within the tank. The ideal tunnel has the viewer at some point surrounded by water so that in whatever direction they look, they only see water. A tunnel design can, and many times does span beyond 180° to provide the viewer with a panoramic view of the tank interior. This type of design requires some unique coordination regarding the installation.

Optimized Aquarium Tunnel

There is an option other than the cylindrical design when designing tunnels. Since the water pressure at the top of the tunnel is less than the water pressure at the bottom, the acrylic window designer can take advantage of the differential and provide an optimized tunnel profile that is more elliptical in shape. When the width of the tunnel gets wide and the shape is cylindrical, the top of the tunnel starts getting quite high. If the top of the tunnel is too far above the heads of the people in the tunnel, then the feeling of being underwater starts to be lost. Optimizing the tunnel brings the top of the tunnel closer to the people in the tunnel, returning that intimate underwater feel. Properly designed, the optimized aquarium tunnel shape can lower the stress and movement of the acrylic tunnel; thus, the design thickness can be reduced, providing a cost savings as well better aesthetics. The optimized design works best for tunnel profiles that are very wide where the water is not too high above the top of the acrylic. Optimized tunnel sections are specific to the width and depth of the tunnel. The optimized tunnel can be worked into numerous aquatic environments and its design naturally varies on width and depth. However, this type of design works best in a wide aquarium space and just below the surface of the water.

Rectangular Aquarium Tunnel

Tunnels can be made in a rectangular shape. This is an expensive option because the acrylic needs to be thicker than with the cylindrical or optimized design options since the tensile stresses tend to be quite high. The rectangular shape also offers the poorest view. Unlike the curved tunnel designs which offer uninterrupted views, the flat panel tunnels have a disjointed view since the animals must swim past the corners of the acrylic panels that are on different planes. Because of these disadvantages, rectangular tunnels are not the choice of architects designing aquaria.

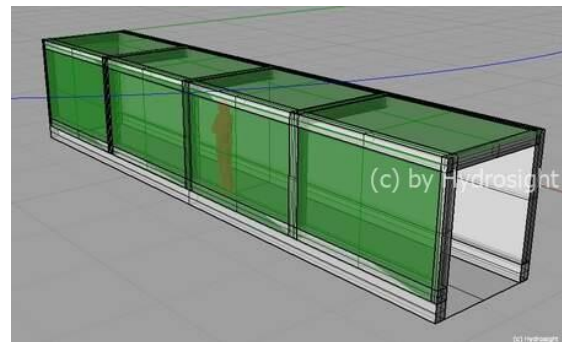

Figure 2. 21: Rectangular Tunnel

Construction Technology of tunnel tanks:

Modern materials and technology have made it feasible to create attraction displays that were previously impossible. Might earlier generations have imagined a place where individuals could observe polar bears swimming by above while being at room temperature, for instance?

Or swimming securely through a transparent tube in waters where sharks are present? Most certainly not, yet acrylic is used in numerous places nowadays to offer similar surrealistic experiences. This material, which can be fabricated into practically any form or dimension, is entirely transparent, stronger than concrete, and lighter than glass, and is used almost exclusively nowadays for aquarium and zoo windows.

Materials Used

- Polyethylene
- Polypropylene
- Acrylic Plastics
- Fluorocarbon plastics
- Fiberglass

Sealant:

- Epoxy resins
- Silicone rubber
- Polyvinyl chloride
- Neoprene

The construction of the tunnel is implemented with the following steps:

Step 1: Alignment

- The tunnel is aligned on the site to be constructed.

Step 2: Excavation

- After the alignment the site is excavated for the installation of the foundation for the tunnel to rest. Pile
- foundation is laid on the respective site and the tunnel to be inserted is laid on those foundations.

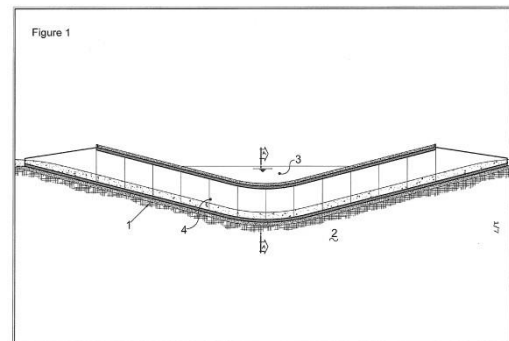

Figure 2. 22:Alignment

- The tunnel which is to be laid is prefabricated and is laid on those foundations.

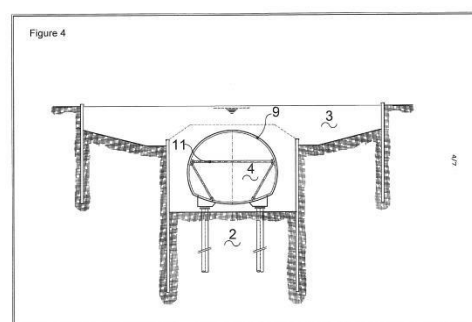
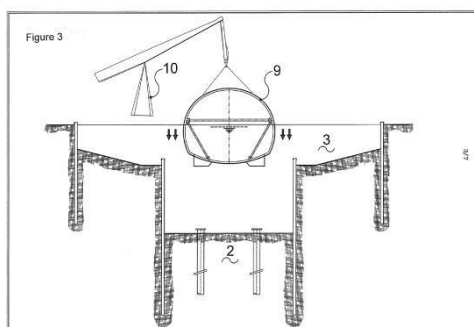

Figure 2. 23:Excavation, Insertion of pile foundation and Tunnel

Step 3: Connection

- The whole tunnel structure is difficult to construct so the construction is done on the instalment basis. The connections are done at the upper and lower level through key and groove as shown in the picture.

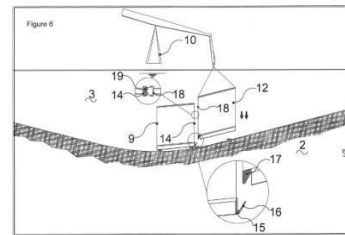
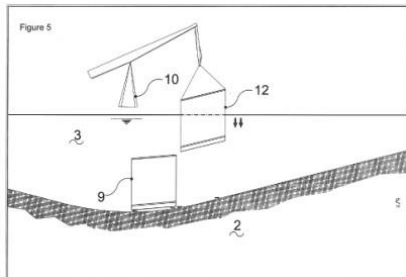

Figure 2. 24: Connection

Step 4: Dewatering

- After the completion of the tunnel the water present in the tunnel are pumped out of the tunnel to make it function. The dewatering is done at the end to maintain the pressure of the water during construction and prevents from obstacle during construction.

Tunnel size varies according to vision required and people-flow capacity. Span 2.8m, 3.4m, 5m or revolutionary 360 profile are available. Certain structural limitations are also placed on each profile, depending on water pressure, spans, tunnel layouts, etc. A moving conveyer may be installed in any tunnel if required, usually only used in tunnel over 50m in length.

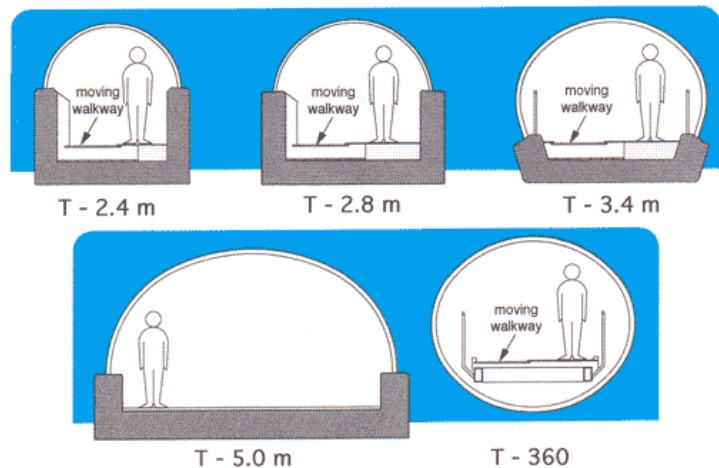

Figure 2. 25: Tunnel sizes, source: bossgoo.com

a. Chemical Components in Display Tanks

A. PH

- A range of 6.5-7.5 is suitable for most of tropical fishes.
- A range of 7.2-8.4 is suitable for marine.

B. Salinity

Salinity describes the content of the dissolved salts and minerals in the water and is measured in parts per thousand (ppt). It should be between 28-32ppT

- NITRITE- 0.1 ml per liter or less

- NITRATE- 20 ml per liter or less
- OXYGEN- 4 To 8 ml per liter

C. Temperature

- Ideal range for a freshwater tank for most tropical fish is 77 to 83 degrees
- For a saltwater tank, the range is 76 to 82 degrees.
- For the reef aquarium, slightly cooler at 76 to 78 degrees is best.

D. Alkalinity

- Alkalinity of water refers to the calcium hardness of the water.
- The required alkalinity is 120 ppm.

E. Hardness

- Hardness of water is a measure of the dissolve salts calcium and magnesium it should be soft water.

b. Planning of Display Tanks

- It should be easily accessible via public transportation as well as private automobiles.
- Adequate vehicle parking in the area should be given.
- Water quality must be examined.
- The design for visitor guiding will be based on the size of the building and site, as well as calculation of the estimated tourist load.
- A visitor will generally turn right, provided no attractions draw him elsewhere.
- Display tanks should be kept at an angle, with the viewing glass facing the arriving visitor, guiding them in that direction.
- Open-floor exhibitions can act as barriers while simultaneously drawing people along the intended path.
- Display tank positioning should be varied to minimize monotony.
- Alcoves and jut-outs will add variation and surprise, as well as act as boundaries between special exhibitions.
- Handrails to keep the general people at least 3 feet away from the viewing glass may be ideal.
- When there are a great number of visitors, a rail keeps them away from the glass, giving more people a better view.
- A step-up for tiny children that is about 1 ft high, and 1 ft broad is commonly given, and it should be part of the building structure and continuous.

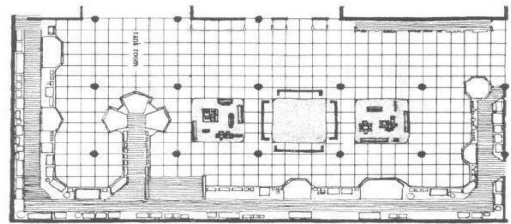

Figure 2. 26: Tank layout, source: Time-saver



Figure 2. 27: Varied Display tank positions, source: oceanaquarium.com

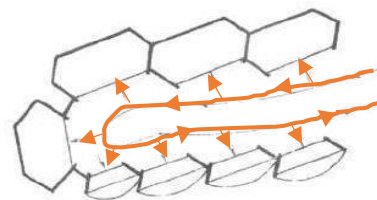









Figure 2. 28: Visitors flow pattern, source: Time-saver standards

c. Display species

Some of the species for marine and freshwater plants and animals are as follows:







Marine plants

Table 2. 1: List of Marine Plants

Species	Size	Tank Size	Water condition
1. HALIMEDA PLATS 	3"4"	13*6*8	72-78° F, dKH 8-12, pH 8.1-8.4, sg 1.023-1.025
2. KELP ON ROCK SMOOTH LEAF 	6"8"	13*6*8	72-78° F, dKH 8-12, pH 8.1-8.4, sg 1.023-1.025
3. KELP ON ROCK GRAPE 	2"6"	13*6*8	72-78° F, dKH 8-12, pH 8.1-8.4, sg 1.023-1.025
4. MAIDEN HAIR PLANT 	2"6"	13*6*8	72-78° F, dKH 8-12, pH 8.1-8.4, sg 1.023-1.025
5. MERMAIDS FAN PLANT 	2"6"	13*6*8	72-78° F, dKH 8-12, pH 8.1-8.4, sg 1.023-1.025
6. RED MANGROVE PROPAGULE 	2"6"	13*6*8	72-78° F, pH 8.1-8.4, sg 1.020-1.025, KH 8-12
7. SHAVING BRUSH PLANT 	2"6"	13*6*8	72-78° F, dKH 8-12, pH 8.1-8.4, sg 1.023-1.025



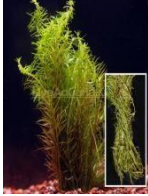



Fresh water plants

Table 2. 2: List of freshwater Plants

Species	Size	Tank Size	Water condition
1. ANUBIAS CONGENSIS 	1' 4"	17 x 9 x 11	72-80° F, KH 4-18, pH 5.5-9.0
2. CABOMBA 	1' 8"	17 x 9 x 11	72-82° F, KH 3-8, pH 6.5-7.5
3. CARDINAL PLANT 	1'	17x9x11	72-82° F, KH 3-8, pH 6.5-7.5
4. HYGROPHILA ANGUSTIFOLIA 	1' 8"	17x9x11	72-82° F, KH 3-8, pH 6.5-7.5
5. ROTALA NANJENSHAN 	1' 2"	17x9x11	72-82° F, KH 3-8, pH 6.5-7.5
6. DWARF BABY TEARS 	6"	13 x 6 x 8	68-82° F, KH 0-10, pH 5.0-7.5
7. ROTALA MAGENTA 	1' 2"	17x9x11	72-82° F, KH 3-8, pH 6.5-7.5







Pond plants

Table 2. 3: List of pond plants

Species		Size	Tank Size	Water condition
1. PERRY'S DOUBLE WHITE		4"	13 x 6 x 8	45-75° F, pH 6.1-7.5
2. BOG LILI		2"	17x9x11	70-80° F, pH 6.5-7.5
3. COLORATA		6"	17x9x11	70-80° F, pH 6.1-7.5
4. CHAWAN BASU		4"	24X13X17	55-80° F, pH 6.0-9.0
5. BLACK GAMECOCK		3"	17x9x11	70-80° F, pH 6.0-7.5
6. SPIDER LILY		2"	13x6x8	60-80° F, pH 6.1-7.8
7. HORNWORT (DOZEN)		2"	17x9x11	59-86° F, KH 5-15, pH 6.0-7.5





Fresh water species:

Table 2. 4: List of freshwater species

Species		Size	Tank Size	Diet
1. GOLDFISH		6"	24 x 9 x 13	Carnivore
2. ANGEL FISH		6"	24 x 9 x 17	Carnivore
3. RAMI REZIS		3"	24 x 9 x 17	Carnivore
4. BLUE KHIGHT LOBSTER		12"	37X19X20	Omnivore
5. BLACK SHARK		2"	48 x 19 x 22	Omnivore
6. FRESHWATER CLAM		2"	24 x 9 x 13	Omnivore
7. NERITA SNAIL		1"	13 x 6 x 8	Omnivore

Marine species:

Table 2. 5: List of Marine species

Species	Size	Tank Size	Diet
1.DAMSELFISH 	3"	48 x 13 x 14	omnivore
2.CLOWNFISH 	3"	48 x 13 x 14	omnivore
3. BLUE GREEN CHROMIS 	3"	48 x 13 x 14	omnivore
4. FIREFISH 	3"	48 x 13 x 14	Carnivore
5. KAUDERN'S CARDINAL FISH 	3"	48 x 13 x 14	Carnivore

2.3.2 Quarantine Areas

The practice of quarantining new aquarium arrivals is a fundamental part of proper aquarium husbandry. Quarantine tanks should be used prior to introducing any new aquatic life. Every time new aquatic life is introduced to aquarium, there is always the potential of also introducing unwanted parasites or disease-causing organisms. In addition, aquatic life stressed from transport and relocation are more susceptible to succumbing to any parasites or disease-causing organisms present in the new environment. Therefore, a quarantine tank is a vital piece of equipment.

2.3.2.1 What are the functions of Quarantine Area?

In addition to minimizing the potential spread of infectious disease, quarantine tanks boast many other practical uses. After all, they are basically an "extra" aquarium that's ready for use. As part of the quarantine process, they can be used to condition new fish to new water parameters as well as diet in a safe, stress-free environment. They are a "recovery place" for newly purchased fish. Here the newcomer can recover the forces lost due to the stress of transportation, adapt to new water conditions, and settle in without immediately having the pressure of the other fins. Stress can in fact significantly reduce the immune response of the fish and allows the organisms that cause diseases to exploit their weakened state.



Figure 2. 29: Quarantine Tanks, source: aquariumtechnology.com

When not in use for quarantine, these tanks can also be used as treatment tanks. Medicating or treating the entire aquarium display for a problem that affects only a few fish is not good practice. Quarantine tanks allow only the infected fish to be treated, leaving sensitive species or water quality in the main display aquarium unaffected by medications. They can be used temporarily to house the inhabitants of the aquarium in case of unexpected emergencies. Have you ever wondered what would happen if the main aquarium stopped working? Where would the poor fish end up? Having a second tank is also very important for this reason. Other uses for quarantine tanks include a breeding tank for fish, a recovery tank for harassed fish, or a "grow out" tank that allow newly hatched fry to mature in safety.

2.3.2.2 What size quarantine tank should be used?

A good quarantine aquarium has a capacity of 20-30 liters and can reach a maximum of 110 liters, to be suitable for both freshwater and marine fish. The size of the aquarium depends on the number and size of the fish you intend to place inside it. The tank can be a little smaller than the one where the fish will live permanently, the important thing is not to create overcrowding. The overall holding capacity should equal one-third of the display volume, although it may differ significantly based on the size of the specimens and display tanks, the replacement demand, the death rate, and other factors.

2.3.2.3 How long should fish be quarantined?

It always depends on the specific case; in principle the period is between 2 and 4 weeks. This time lag is used to make sure that the fish is healthy or completely healed and to monitor that it does not have strange behaviors that can cause problems for other fish. During that time,

they are treated for parasites with a copper-based treatment for 14-21 days, and for bacterial infections if there are obvious symptoms (ragged fins, red spots, etc.). 10-15% of water change every other day must be done to keep the inhabitants of the quarantine tank healthy.

2.3.2.4 What equipment is needed for quarantine tank?

Most quarantine tanks are set up with lighting, a heater, easy-to-clean rocks, and pvc tubes or plastic plants to provide the fish with much-needed cover. For filtration, a sponge filter works well and the sponge can be colonized with nitrifying bacteria by placing it in the sump of your wet dry filter, or in the main display if a sump isn't available. Make sure to disinfect and rinse well between uses. Substrate is unnecessary and not having substrate keeps cleaning and disinfecting quarantine tanks easy. All quarantine tanks should be provided with drain valves to permit rapid drainage after treatment procedures. All tanks should have removable pump screens.

Inside it is sufficient to install the basic equipment, i.e., a simple sponge filter, heater, thermometer, lighting and possibly an air pump. The temperature and PH of the water must be the same as in the main tank, in order not to risk making mistakes, you can transfer the main water to this quarantine. (liveaquaria.com, 2022)

2.3.2.5 How to disinfect quarantine tank?

Aquariums and equipment can be disinfected between uses with a mild (2-5%) bleach solution. All traces of bleach must be rinsed off before re-using. As an added precaution, chlorine neutralizer can be used to effectively remove any potential residual chlorine. Drying also kills many but not all aquatic pathogens. Separate siphon is needed for quarantine tank and must be disinfected well between uses. (liveaquaria.com, 2022)

2.3.3 Loading and Receiving Areas

It is essential to load and unload the live specimens that are moved to and from the aquarium on a regular basis since failing to do so might be fatal to the specimens. There should be a separate entry to this location along a motorable road. Additionally, a wide enough access road from the loading bay to the quarantine as well as the operating areas must be provided for forklifts and other smaller loading vehicles.

2.3.3.1 Fish Transport

As the objective of transportation is the fishes to arrive at the aquarium in good condition, small number of fishes should be carried out at a time. Aeration is usually necessary during transportation depending on the fish load, the water temperature, the duration of the journey and fish condition. If continuous supply of air is difficult or impossible, fishes can be placed in airtight bags that will be blown with air. Plenty of air volume should be above the water surface, the recommended water: air ratio being 1:4 (Taylor and Solomon, 1979). Fish biomass should not exceed 100gr per liter of water.

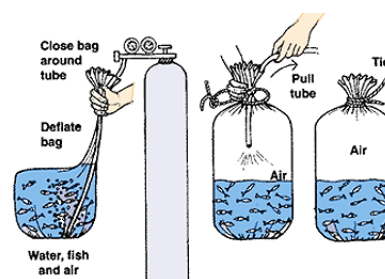

Figure 2. 30: Fish transportation technique, source: fao.org

If transportation takes place in airtight bags, the whole operation should not last more than 4-5 h as carbon dioxide and ammonia build up in the bag and may harm the fishes (Taylor and Solomon, 1979). It is advisable to use a tranquillizer during transportation. The drug will slow down fish metabolism and therefore decrease oxygen demand and carbon dioxide/ammonia production. In addition, fishes with less stress are less likely to be injured on the tank walls because of anxiety and intense movement.

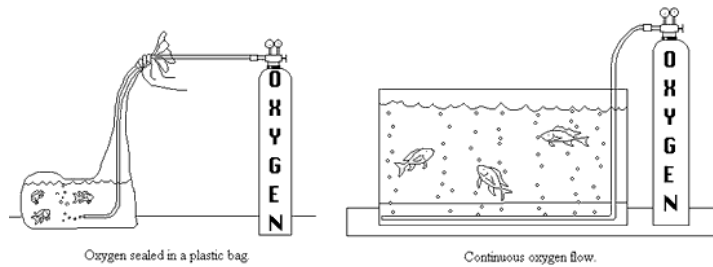

Figure 2.31: Various method of Transportation, source: thefishsite

2.3.4 Administrative Areas

Any aquarium must be monitored and run well, hence an administration area is important. This section needs offices for the curator, chief aquarist, marine scientists, chief engineer, and volunteers, among other things. It is desirable to have a visual link to both exhibition spaces and maintenance facilities. Administrative area is mostly preferred towards such a space in the site from where overall command of the whole complex can be generated.

2.3.5 Operation and Maintenance Areas:

Operations areas are the "behind the scenes" sections where aquarium tank maintenance and general management are carried out. In the case of a normal aquarium, only the remaining portion of the building is open to the public, with the operations section taking up roughly 60% of the total floor. The facility is usually solely thought of from the perspective of the visitor by aquarium planners.

They do not realize that the welfare and attractiveness of the specimens and minimum costs for operation and maintenance depend upon the attention given to behind-the-scenes design. These areas are essential for housing the "Life Support Systems (I-SS), absolutely vital for keeping the exhibits alive and healthy." "The immediate work area behind the display tanks

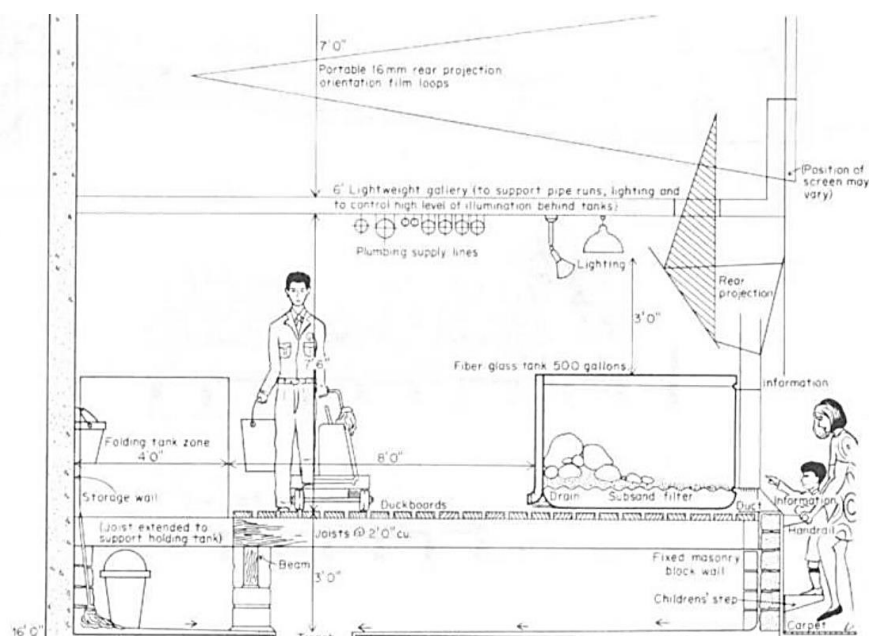

Figure 2.32: Behind the scenes area (Maintenance area), source: Time-saver standards

may be considered first. The work area floor should be about 3ft higher than the public area floor. This is dictated by the height of average visitor looking into the approximate center of the viewing glass of the average large display tank. Most display tanks are placed on the floor of the work area. Obviously, very small and very large tanks will have to be placed differently. Tanks should be placed to permit ease of Cleaning by aquarists.” (Chira, 1983)

All display tanks should have a clear corridor that is at least 6 feet wide along their backs to make it possible to move tanks and incoming specimens with a forklift or four-wheel trailer. There shouldn't be any stairs or other obstacles in this hallway.

Some other necessary specifications for the operations area are:

- The floor of the work area should be finished with nonskid material.
- It is important to offer storage space for tools, nets, chemicals, and other frequently used things.
- Sand traps and sloping floor drains should be installed on the flooring of work areas.
- All areas close to the tank area should be constructed of water-resistant materials.
- It is important to offer storage space for tools, nets, chemicals, and other frequently used things.
- Refrigerators are frequently practical for the storing of specialty foods and may cut down on trips to the kitchen.

Fooding and Feeding

Feeding aquarium organisms shows some complexity as they are many different species including vertebrates and invertebrates; the aquarium stock varies not only in species composition but also in age and size within the same species. Feeding aquarium animals is not therefore easy as some species do not easily accept routine feeding as feeding behavior plays an important role in some species. Therefore, four categories of fish food should be available in a public aquarium:

- (a) commercial foods used in aquaculture farms usually in the form of pellets
- (b) commercial foods used in home aquaria usually in the form of flakes
- (c) fresh food such as fish flesh and invertebrates (*Cisse et al., 1995*) and
- (d) live food (i.e. *Artemia*).

Feeding practices should consider ration size, growth rate, temperature, and body composition. Many fishes locate food by eye others by movement. They can also detect the food through the sense of smell. As fishes rely on chemoreceptors, they examine food thoroughly before eating. Rejection of commercial foods may be due to pellet size, shape, taste and hardness. The situation can be improved if taste attractants are added to the food. It has been found a long time ago (*Fujija and Bardach, 1966*) that several amino acids act as attractants causing a positive response of the fishes to food pellets. Fish food was also becoming attractive for some species if nucleotides were added (*Kiyohara et al., 1975*). Among the amino acids, glycine and

alanine were found the most effective when added to food. Nowadays, commercial aquarium foods are well balanced in nutrient and attractants to fishes.

Abiotic parameters can also affect feeding behavior: light intensity can affect feeding habits; the optimal light intensity is depending on the species. Noise is always a negative factor for fish appetite. It has been found that low frequency noise (below 100Hz) caused fright reaction to herring (Cowey, 1981). Aquarium “scenery” can also affect feeding behavior. It has been reported by some authors (Hawkins, 1981) that sandy bottom helps flatfishes to eat, whereas pipes seem to improve eating habits of eels. Social factors can also be critical. Overcrowding or dominant individuals may cause problems that affect the feeding of fishes. Overcoming the difficulties in fish feeding is more a matter of craft and experience of the curators. Different conditions from one public aquarium to another or even from one tank to another need special attention.

It is necessary sometimes to use live food. Water fleas (Daphnia) have been recommended for several fishes. The brine shrimp (Artemia) has been found attractive as a live food source and produces much better survival in juveniles. Mosquito larvae can also be used. They are attractive as food and do not consume dissolved oxygen as they surface and breathe atmospheric air. There are no strict formulations for fish food and therefore empirical preparations can work well. Hence or otherwise fish curators should not have in mind the fish growth as the main objective of a public aquarium is to display healthy fishes. As uneaten food increases the organic load of the system, it is advisable that aquarium staff stick to the old rule (Innes, 1966).

“Feed only enough prepared food at one time so that practically all of it is consumed within 5 minutes”

2.3.6 Supporting Areas:

A. Visitor Information Center

These facilities must be placed conveniently close to the entrance so that guests may stop by there before beginning their tour around the gallery and obtain any necessary supplies or information. The facility includes information booth ticket counter, visitor lockers, wheelchair and stroller renting and public toilets.

Successful aquariums have many visitors, and the queues often go for many blocks. Proper attention needs to be paid for queueing spaces and ticket sales points at Entry.

This could mean a queue up to a few hundred meters on peak days. Ticket selling points need to be variable to cater for slow and busy days. For an aquarium of this size, you could need up to 4 on a busy day to cope. It is good to have an office adjacent to the ticketing to handle the cash sales in enquiries and information and group arrivals.

A. Conservation and Education Center

This is a special space created to serve the educational objective of the public aquarium is comprised of interactive science-based exhibits on the topics of water conservation, our local waterways, and the effects of plastic on our rivers and oceans. As aquarium tend to have large group of visitors at once from educational institutes frequently, this space is created to receive them, provide them with necessary orientation and create groups under supervision before the tour may begin.



Figure 2. 33: Education Center, Source: stlaquariumfoundation.org

Fish Draw: The Fish Draw is a popular destination for Aquarium guests both young and young-at-heart. Add your flair to one of the fish coloring sheets, scan it in, and watch it swim in virtual River!



Figure 2. 34: Fish draw, source: stlaquariumfoundation.org

River Dance: River Dance displays the shifts during the river throughout history. Through interpretive signs, guests learn about the people, flow, and attempts to tame this mighty river.

The Globe: At the Digital Globe, explore the world's rivers and waterways through a variety of environmentally focused 360-degree videos.

What's Your Watershed: See the big picture of our country's water flow at the What's Your Watershed? Enter a zip code or location to see where the water flows from to get to the selected location and where the water flows after we use it (hint: usually the ocean).



Figure 2. 35: River Dance, Source: stlaquariumfoundation.org

Get Involved! Action Kiosks: At the Action Kiosks, guests can access information about getting involved in water conservation activities in our region, take the Eco-Footprint Quiz to see how our actions affect the environment, and learn ways to protect our waterways.

Plastic Bottle Sculpture: The Plastic Bottle Sculpture is a beautiful and poignant exhibition of plastic bottles. At interpretive signs, guests learn about plastic pollution and global solutions.

Species Discovery: Species Discovery features four animals that can be found in or near regional waterways and are representative of how animals can affect and be affected by water quality.



Figure 2. 36: Discovering waterways, Source: stlaquariumfoundation.org

River Clean-up Game: It takes everyone working together to keep our waterways clean, even at the River Clean-up Game! Up to five interactive games allow guests to find invasive animals, remove plastic pollution, swipe invasive plants, clean up trash, and find ways that toxins enter the river. Working as a team, though, you can make our river sparkle!



Figure 2. 37: River Cleaning game, Source: stlaquariumfoundation.org

Rain Garden: The Rain Garden is a beautiful outdoor space in the Conservation & Education Center featuring signs explaining how a rain garden works and how it can benefit the environment and health of our waterways. You can also learn how to create your own rain garden. With the help of some dedicated volunteers, we grow vegetables and plants that are used to augment aquarium residents' diets.

B. Orientation Hall

Hall should be equipped with a projection room, which is necessary for orientation classes, illustrated lectures as well as films. They should be near the entry lobby and easily accessible. Care should be taken that the students might directly process to the exhibits after orientation without having to retrace the steps back to the main entrance. It doesn't necessarily need to accommodate all the students or group members that visit at once but should hold a reasonable number of people. Waiting lobby and other supporting spaces should be provided outside the hall so that the remaining group members may wait for their turn in organized a pleasing way.

C. Library

A library is a collection of sources, resources, and services, and the structure in which it is housed. In academic library reference rooms are provided. There may be also counters for loans from the closed stacks and free access to open shelves of magazines, book or separately presented educational material in reading rooms.

The number of reading place depends on the number of students on the various subjects. The information is arranged in the systematic way, i.e., by subject. The service offered include interlibrary loan as well as photo copying, reading, and printing from microforms along with a literature search on data based stored on CD-ROM are available.

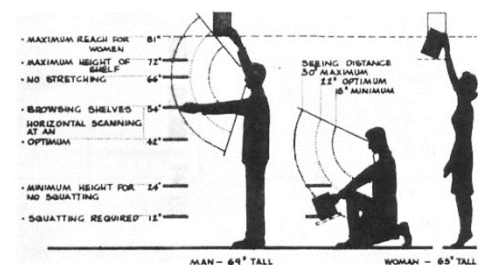

Figure 2. 38: Shelving standard for adults, source: Time-saver standards

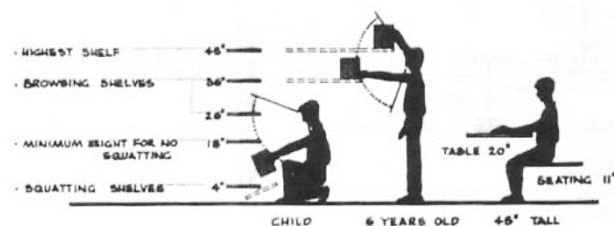

Figure 2. 39: Shelving standard for children, source: Time-saver standards

Reading room areas, with space for reading and working, should be easily accessible and therefore situated on as few levels of possible. The area in a library can be categorized into three different parts which are as follows:

- Service Area

Circulation route > 1.2m wide
Figure 20: Study area and services

Clear span between shelves at least 1.3-1.4 wide

Avoid crossing of route for users, staff and book transport

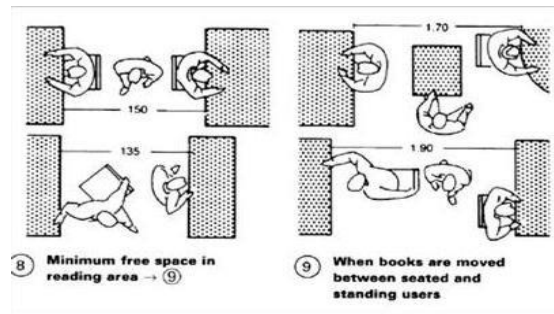

Figure 2. 40: Study area and services, source: Time-saver standards

- Reading Area

Place readers at least 18" away from the wall

The ceiling height of 9'6" up to 11"

- Stacking Area

Stack area is one of the important parts of the library. The area can be made attractive by placing the book stacks of different colors on different levels. Wall shelves in a large reading area are seldom desirable, as they require wide aisles in front of them. Shelving can be more economically on the range with shelving on both sides, as the aisle then receives full use. Aisle width should be wide enough so that the bottom shelves can be adequately lighted, and two persons can pass each other without too much difficulty.

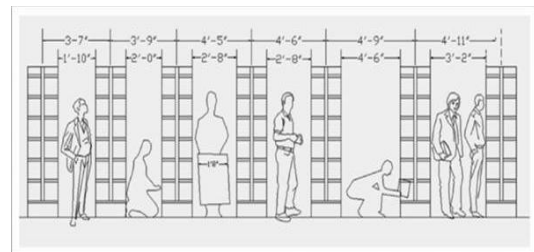

Figure 2. 41: Stacking Area, source: Time-saver standards

D. Cafeteria

Before any restaurant or inn is built, the organizational sequence should be carefully planned. One person requires a table area of around 60 cm wide by 40 cm deep. Although an additional 20 cm of space in the center for dishes and tureens is sometimes desirable, an overall width of 80-85 cm is suitable for dining table. Round tables, or tables with six or eight, with diameter of 90-120 cm are ideal for four people and can also take one or two more dinner.

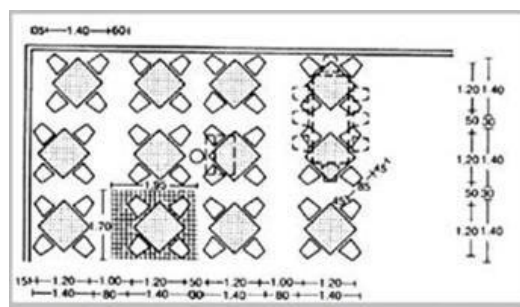
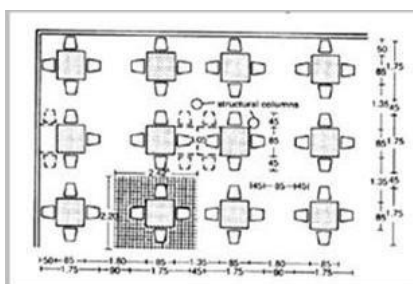

Figure 2. 42: Dining room layout, source: Time-saver standards

Dining and Kitchen

Dining and kitchen can be provided separately or within the same building. Space requirement depends on the service provided and the arrangement of the furniture's. Kitchen should be big enough not disturbing the flow from storage to service area. The area of kitchen should permit the following activities comfortably:

- Storage (gathering materials needed for the performance of the task)
- Cleaning and mixing (initial preparation)
- Cooking
- Serving or storage for future use
- Cleaning up

Table 2. 6: Space allocation

Functional Area	Space allowed (%)
Receiving	5
Food Storage	20
Preparation	14
Cooking	8
Baking	10
Ware washing	5
Traffic aisles	16
Trash storage	5
Employee Facilities	15
Miscellaneous	2

Dinning

General- 1-2m²/students, allowing for number of siting

For long table and chair arrangements,

Width of seat- 600mm

Width of table- 700mm

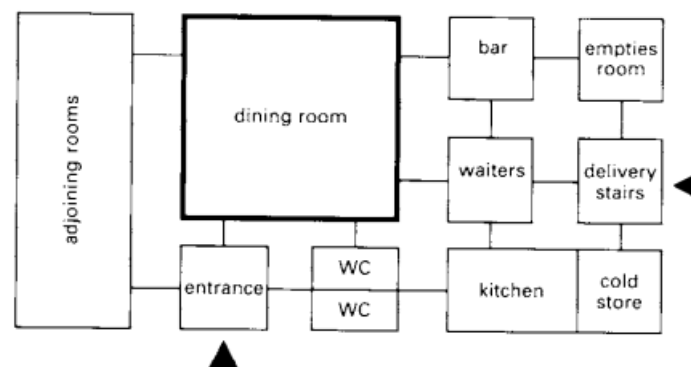

Figure 2. 43: Functional layout for restaurant, source: Neufert

E. Gift Shops

Gift shops are normally placed towards the exit of the aquarium. Many times, visitor exit may take place via the gift shop. Only around 50% of the aquarium's revenue comes from ticket sales. The rest comes from Food & Beverage (F&B), retail sales, education, interactions, functions etc. at least 25% of the revenue can come from retail sales. Studies indicate that when you don't exit immediately via the shop about 50% of this revenue is lost. Many sales are impulsive. It is important to capture this.

F. Display Museum

The Display Museum or "dry museum" is generally kept towards the end of the visitor circulation and the exit should lead towards the museum. This space focusses on showing historical and Evolutionary events that may relate with the live exhibits displayed in the gallery. It generally may hold fossils, dry exhibits and other historical artifacts that can be displayed to the visiting public. This space may also be used to display information about any particular species that may possess great significance to a public aquarium but isn't available in the public aquarium due to technical financial or any other reason. E.g., Gangetic Dolphins (in case of Nepal).



Figure 2. 44: Fish Museum, source: Naturalis Biodiversity Center

G. Research Center

Research activities are considered as a primary objective in many public aquaria. Many reasons have been reported for the growing interest on research in public aquaria: increased interest in conservation and biodiversity issues, the need for applied research to solve management problems, the growing interest to environmental sciences and environmental protection as well as the availability of animal stock for experimenting in the aquarium tanks. The fields of study cover a broad spectrum of scientific disciplines: behavior, nutrition, demography, genetics, reproduction, life histories, auto ecology, marine ecology, and wildlife management. As public aquaria have extended their scientific programs to environmental issues on coastal ecosystems and coastal water quality are within their interests. (Karydis, 2011)

Research in an aquarium shows both advantages and shortcomings: research needs, scientific and technical manpower that comes from the staff managing the aquarium but also needs financial contribution and administrative support. On the other hand, research improves the scientific quality of the personnel involved, makes fund raising easier and promotes collaboration with research centers and universities. This collaboration promotes educational goals for both sides and allows benefits through shared resources (Freistner and Price, 2002). Academic Institutions offer library and laboratory facilities as well as research staff highly qualified in laboratory methodology. Public aquaria offer the animal stock and infrastructure for keeping them for experimentation.

The laboratory should be designed for people who conduct research and to provide them with a safe and pleasant work environment that leads to increased productivity, higher retention rates and easier recruitment of new staff. Direct natural light and view to the exterior, adequate workspace, appropriate color, a coordinated and well-organized layout, attractive and functional casework, and amenities such as exercise facilities, cafeterias are some of the design features that will enhance the quality of life. Gone are the days when labs used to be cramped spaces with no proper lighting and ventilation. Today, not just lighting and ventilation are the major issue, but researchers are also of utmost importance. The main objective of this part of literature review is to understand various lab spaces and their planning.

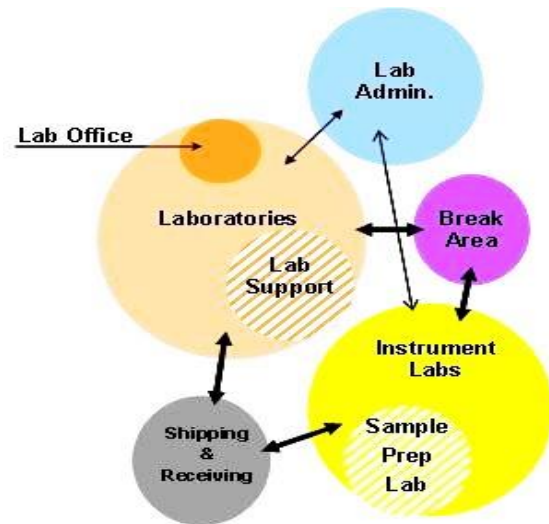

Figure 2. 45: Laboratory Relationship Diagram, source: NIH biomedical lab design guide

Laboratory Space:

The distribution of laboratory services should be reliable and predictable thanks to the laboratory module. As changes of use are required by changes in research direction and in procedures or equipment; partitions should be able to be relocated, doors moved, and rooms expanded into larger rooms or divided into several smaller rooms without disturbing adjacent laboratories or building utility systems.

An individual laboratory module can be anywhere between 10'-0" and 12'-0" wide. Laboratory module widths are often calculated using the following

- 5'-0" aisle width
- Bench or equipment space on each side of the aisle 3'-0" each side of this aisle.
- The width of a laboratory planning module should be 11'-0".
- The depth of a laboratory module is determined by how many people will work at the bench the types and size of equipment to be placed in the work area, the amount of desk space, and placement and frequency of containment units such as fume hoods and bio safety cabinets. The ideal depth of the laboratory module is 33'-0".

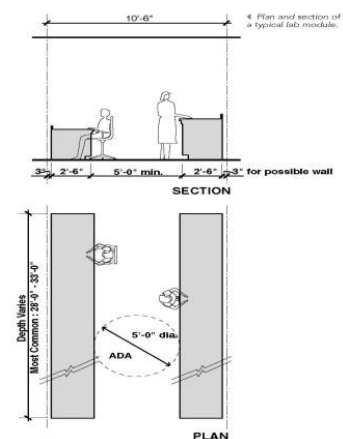

Figure 2. 46: Lab Module

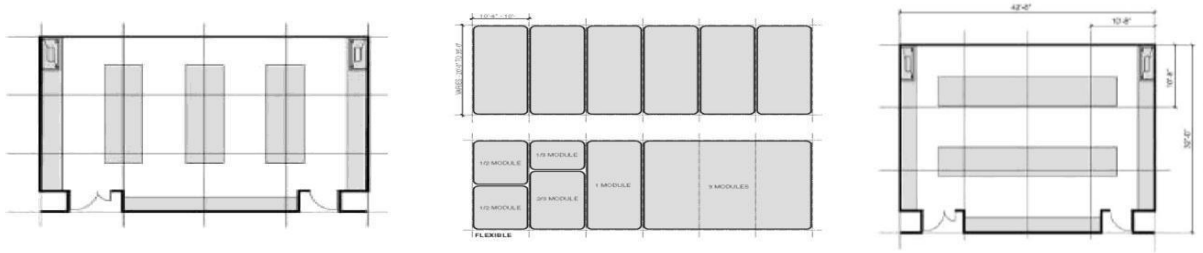

Figure 2.47: Lab Module, source: NIH biomedical lab design guide

For laboratory space, rectangular module with 3-4 m wide by 6-7 m is mostly preferred. Square module is also used that allows square bench arrangement.

General thumb rule: The following table shows general rules of thumb to be used in planning laboratories for budget purposes. The data assume two persons per module. The laboratory support space is based on 50% of the laboratory.

Table 2.7: General Rules for planning Biomedical Laboratories, source: NIH biomedical lab design guide

Space	Area(m ²)	Area (Sq. ft)
Laboratory space	16.50	181.5
Laboratory Support Space	8.25	90.5
Research Staff Office	2.79	30.0
Ancillary space	0.84	9.0
Laboratory Administration	2.88	31.0
Optimal Area per Researcher Assigned Bench Space	31.26	342.0

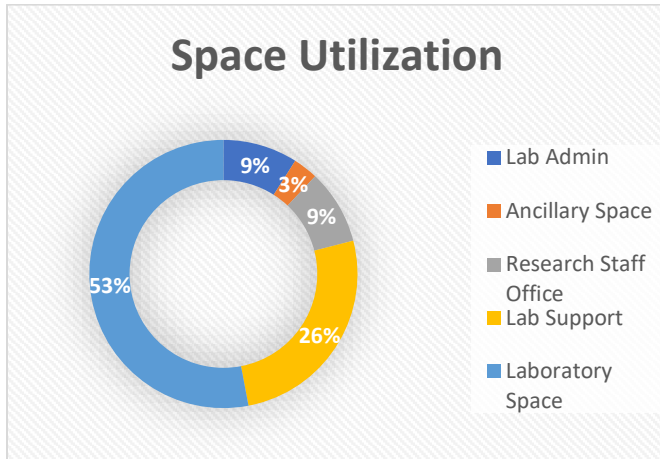

Figure 2. 49: Space Utilization, Source: NIH biomedical lab design guide

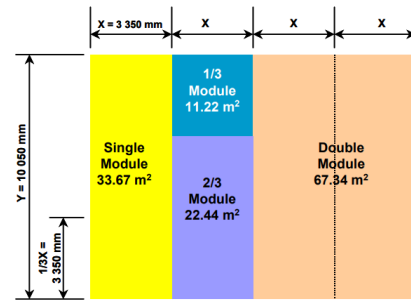

Figure 2. 48: Lab Module, source: NIH biomedical lab design guide

Laboratory support

- Laboratory support space should be on the same planning module as the laboratory.
- It should provide for activities that are not housed directly in the laboratory but are critical to the efficient operation of a laboratory.
- This space is often shared by multiple laboratories and includes areas such as autoclave rooms, environmental rooms, computer rooms, darkrooms, developing rooms, equipment areas, glass wash, bench support, radioactive work areas, ice rooms and storage.
- Consideration should be given to locating noise, heat and vibration producing equipment in laboratory support spaces.

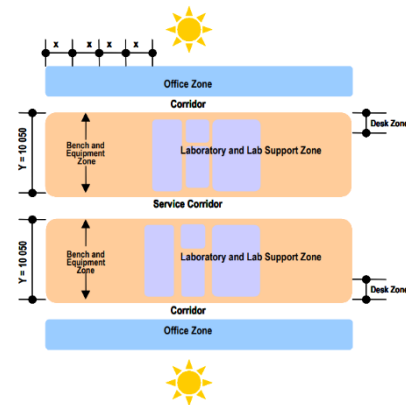

Figure 2. 50: Laboratory and Laboratory Support Concept, source: NIH biomedical

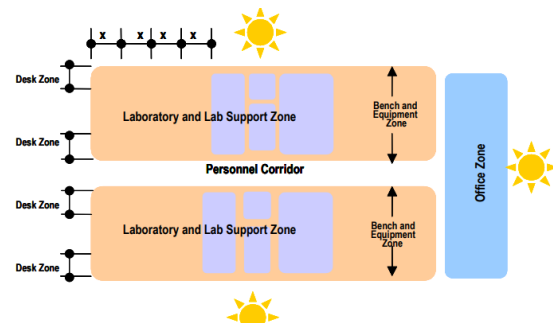

Figure 2. 51: Laboratory Zones with Single Corridor, source: NIH biomedical lab design guide

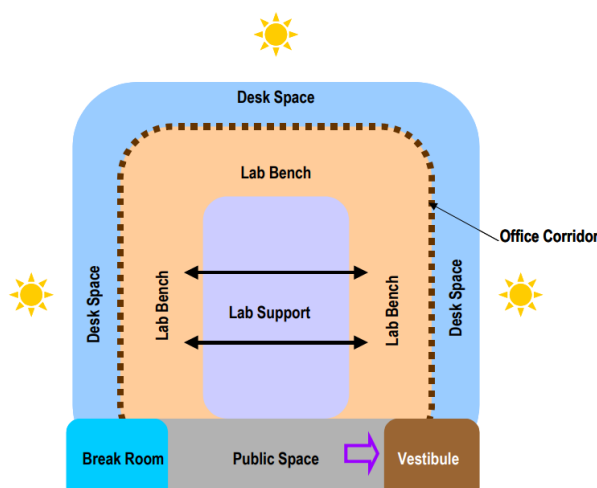

Figure 2. 52: Laboratory pod concept, source: NIH biomedical lab design guide

Laboratory, administrative, interaction and ancillary space:

Labs

Table 2. 8: Space Schedule for Instrument Laboratories and Special Function

Space Name	M ² (Sq. ft) per Person*	Equipment/Furniture and Requirements	Hgt. m (ft)
Bio-Chemistry	16.50 (185.5)	Equipment/furniture: fume hood and/or BSC, epoxy sink w/eyewash, drying racks, tall storage cabinet, cylinder restraints, case work with acid proof work surfaces w/shelves, refrigerator, freezer, undercounter refrigerators, flammable liquid storage cabinet, corrosives storage cabinet, bench top centrifuges, desk and chair, recycle bins and safety shower. Recommended Laboratory Shared Support Requirements: 40c cold room, free standing equipment room and ice support room.	3.0 (9'-6")
Molecular-Biology	16.50 (185.5)	Equipment/furniture: fume hood and/or BSC, epoxy sink w/eyewash, drying racks, tall storage cabinet, cylinder restraints, case work with acid proof work surfaces w/shelves, refrigerator, freezer, flammable liquid storage cabinet, corrosives storage cabinet, desk and chair, recycle bins and safety	3.0 (9'-6")

		shower. In addition, provide for incubators and shakers, freezers, and dry and liquid waste storage w/ Plexiglas shielding for radioisotope waste. Space may be needed for free standing robotic instruments. Recommended Laboratory Shred Support Requirements: dark room, radioactive workroom, and free-standing equipment room.	
Cell Biology	16.50 (185.5)	Equipment/furniture: BSC, epoxy sinks w/eyewash, drying racks, tall storage cabinet, and casework with low bench, deep shelves, acid proof work surfaces, refrigerators and freezers, flammable liquid storage cabinet. Recommended Laboratory Shred Support Requirements: auto clave, cold room, standard ice support, and low bench support.	3.0 (9'-6")
Tissue Culture	16.50 (185.5)	Equipment/Furniture: BSCs, multiple stacked CO ₂ incubators with central CO ₂ back up CO ₂ tanks, an adjacent sink, deep shelf storage space for plastic ware storage, a refrigerator in the room, a tabletop centrifuge, and a microscope bench. There should be a small amount of working bench space near the sink to prepare media.	3.0 (9'-6")

Office

- Offices should be positioned to achieve proximity to the occupant's laboratory workspace.
- Finish with anti-microbial finishes. If feasible, offices should be provided with natural light.
- Semiprivate offices may be provided for postdoctoral fellows.
- Open office space should be provided for clerical personnel.
- Sound damping and sound insulation should be considered.
- Desk and storage space for laboratory technicians are usually in open areas adjacent to lab benches and should include provisions for privacy.
- Consideration may be given to clustering offices to have potential for sharing support staff.
- Storage requirements must be considered for records/files, copiers, and mail areas.
- Office and file rooms should be lockable.

The facility should have a central reception area located as close to the main facility entrance as possible, where guests and vendors can be met and directed appropriately. The area should have a space for furniture for visitor waiting.

Lockers

Personal space within the context of an open laboratory is much less private and secure than in conventional, enclosed laboratory space. Although there is the option of installing locks on casework doors and drawers, there is an immediate need to provide space for employees to store personal belongings including food and coats, outside of the laboratory. Lockers may be built in and located in the corridors or in the break rooms. Lockers may also be in a separate room.

Back-up rooms/Store

They are used by occupants of more than one lab. They are not used continuously, hence can be separated from standard labs.

Services

They include horizontal and vertical ducts with removable cover, accessed from corridor. The other important part is service spine which consists of fixed shelves of 200mm wide where piped engineering services are fixed.

Conference room

Small conference rooms for 8-10 people shall be provided for formal and informal meetings of section staffs. Large conference rooms for up to 25 people will be provided for meetings of the laboratory staff. All conference facilities will be shared. Each space should be equipped with white boards, outlets to accommodate audiovisual and projection equipment (laptop, slides and overhead projectors), light dimming, and blackout control, as well as telecommunications. Conference rooms should be equipped to accommodate flexible seating arrangements, secure/lockable storage closets, space for waste and recycling containers, and accessibility to permit ease of cleaning and servicing.

Break rooms

These areas permit the safe consumption of food and beverages outside the laboratory while creating an inviting area for interaction. These areas serve as lounges and small informal meeting spaces for the employees. Acoustical separation of these areas from surrounding spaces is required. All break rooms should be equipped with a white board, tack board, table, and chairs. Some larger break rooms may also require a bookcase, cabinets, sink and counter tops, microwave oven, and refrigerator. Lockable storage within a break room is desirable. All break rooms should include space for waste and recycling containers. Furnishings used in a break room must be cleanable and promote good sanitation. A library or resource center could be combined with a conference or break room or be a separate entity. Provide a break area on each floor, or for each laboratory neighborhood. These spaces must be provided with exhaust ventilation to prevent migration of cooking odors. Sufficient electrical receptacles should be provided for food and beverage preparation.

Shower/Changing areas

Personnel showers with changing areas should be provided for each sex. Shower and changing areas are typically adjacent to or co-located with restrooms. Include lockers and changing benches, clothes hooks, and an electrical outlet adjacent to mirror and shelf. Shower and

changing areas shall be accessible to individuals with disabilities. Refer to local plumbing code to determine the number showers required based on building population.

Cyber cafe

This specialty area is a response to the age of computer communication, rapid information retrieval and multitasking. A cybercafe is a multipurpose space containing computer hookups for laptops at desks or tables, a refreshment bar, and informal meeting space. These areas foster interaction among building occupants and draw in others from outside the building.

Library/Reading area

Libraries are no longer as popular or as necessary as they once were with the advent of online journals. However, there still may be a desire for a reading room where current hard copy journals are kept. The library room should be a quiet, comfortable, well-lit space with adequate perimeter shelving for books and journals. It should have electrical and data receptacles for all research desks provided.

Table 2. 9: Space Schedule for Administrative, Interaction and Ancillary Space

Space Name	M ² (SF) per Person*	Equipment/Furniture and Requirements	Hgt. m (ft)
Laboratory Chief's Office	15.0 (160)	Work surfaces w/binder bins, convergent work surfaces, lateral files, tack boards and white boards.	2.4 (8'-0")
Section Chief's Office	12.0 (130)	Work surfaces w/binder bins, convergent work surfaces, lateral files, tack boards and white boards.	2.4 (8'-0")
Principal Investigator's Office	12.0 (130)	Work surfaces w/binder bins, convergent work surfaces, lateral files, tack boards and white boards.	2.4 (8'-0")
Senior Permanent (Tenured) Scientist Office	12.0 (130)	Work surfaces w/binder bins, convergent work surfaces, lateral files, tack boards and white boards.	2.4 (8'-0")
Post Doctoral Fellow's Workstation	10.0 (108)	Work surfaces w/binder bins and lateral files.	2.4 (8'-0")
Receptionist or Chief's Secretary Workstation	8.0 (86)	Counter, work surfaces w/binder bins and lateral files.	2.4 (8'-0")
Clerical Workstation	8.0 (86)	Work surfaces w/binder bins and lateral files.	2.4 (8'-0")
Building Engineer's Office	12.0 (130)	Work surfaces w/binder bins and lateral files.	2.4 (8'-0")
Logistics Office	12.0 (130)	Work surfaces w/binder bins and lateral files.	2.4 (8'-0")

Lockers	0.3 (3)	Lockers and benches.	2.4 (8'-0")
Conference Room	1.86 (20)	Conference table, chairs A/V equipment, white boards, etc.	2.4 (8'-0")
Break Areas		Vending machines, counters, tables w/chairs under the counter refrigerator, recycle bins, and microwave oven with canopy exhaust hood.	2.4 (8'-0")
Shower and Changing Room	Fixtures and equipment determines the space	Lockers and benches. In addition to the area required for plumbing fixtures the area for lockers and benches is 0.3 per person.	2.4 (8'-0")

Layout of the building

A. Single corridor:

Advantages:

It creates Main Street which provides better opportunities for Communication.

Disadvantages:

It limits the width of building with inadequate lighting in corridor. Various options of single corridor system have been studied –

a) Option 1:

In this case, labs and offices are adjacent with offices without direct views to exterior. The offices will not have direct views to the exterior unless the walls between the lab and office have glazing. To get into the main lab, it will be necessary to enter through the offices.

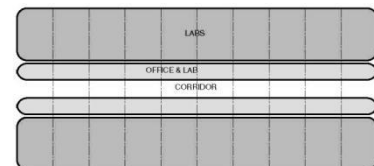

Figure 2.53: Single corridor (opt. 1)

b) Option 2:

In this case, office clusters open into labs and corridor. Internal glazing of offices provides an opportunity to oversee lab spaces. Locating offices directly next to and immediately accessible to the labs is preferred by most researchers but is more costly than offices in a central area.

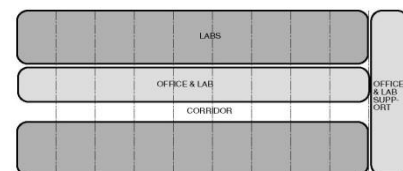

Figure 2.54: Single corridor (opt. 2)

B. Double corridor

Advantages

It provides wider floor plan. Linearity due to single-corridor system is sometimes monotonous which can be compensated by double –corridor system.

Disadvantages

It creates two sides and separates people by creating a building with “two sides”. Various options of double-corridor system have also been studied.

a. Option 1:

In this case, offices are placed on outside and labs at interior. The corridor along the outside wall provides views and natural light for everyone. With this concept, the main labs and support labs can easily be reconfigured as one large lab area, however, at the expense of compromising natural lighting.

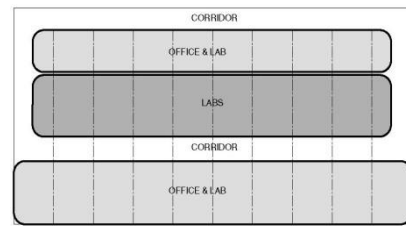

Figure 2. 55: Double corridor (opt. 1) , source: NIH biomedical lab design guide

b. Option 2:

In this case, office –cluster and main labs are placed along external wall while service labs are placed at the interior. The main labs and offices have views to the exterior, but the offices are separated somewhat from main labs by the centrally located support labs. The lab support area will work well for research that cannot have natural light coming into the space.

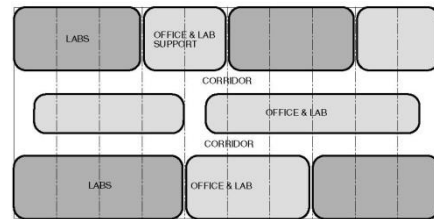

Figure 2. 56: Double corridor (opt. 2), source: NIH biomedical lab design guide

C. Ghost corridor

It is a walkway area through labs. It provides easy access from one lab to another without the need of separate public corridor; hence, it can be termed as secondary means of egress. However, it creates disturbances and reduces security.



Figure 2. 57: Lab with ghost corridor

Utility and Ventilation

a. Shaft at the ends:

Advantage

Useful in renovating older facilities.

Disadvantages

Extensive ceiling space is needed.

Ceilings must be removed for access.

Servicing could disrupt the users.

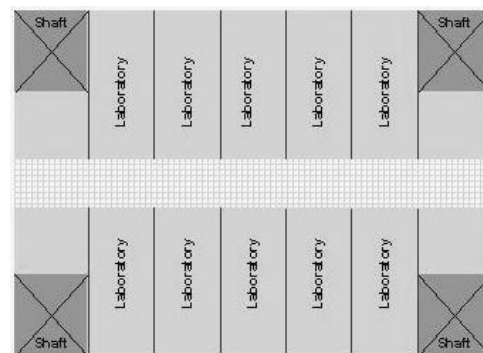

Figure 2. 58: Shaft at the ends, source: NIH biomedical lab design guide

b. Multiple internal shaft

In this system vertical distribution of utility service is via smaller vertical shafts and horizontal distribution is through the ceiling space.

Advantages

- Relatively short horizontal runs are necessary that require smaller ducts and pipes.
- Access to shut off valves is more convenient and less disruptive than when located in ceilings. Requires minimal floor-to-floor height in new facilities.
- Suitable for alterations to existing facilities with low floor-to-floor heights.

Disadvantages

- The shafts constitute multiple obstructions.
- Future service additions are awkward.
- The planning efficiency is decreased, and the grossing factor is increased.

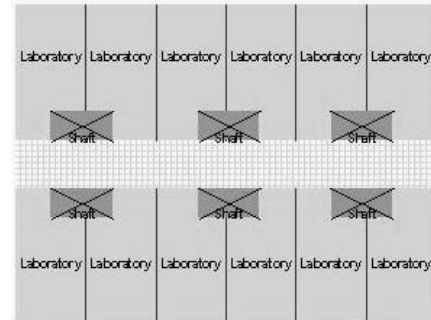

Figure 2. 59: Multiple internal shafts, source: NIH biomedical lab design guide

c. Multiple exterior shaft

Distribution via multiple exterior shafts is like that with multiple interior shafts.

Advantages

- Relatively shorter horizontal runs are necessary that require smaller ducts and pipes.
- Access to shut off valves is more convenient and less disruptive than when located in ceilings.
- In new facilities a minimal floor-to-floor height is required.
- It is suitable for alteration to existing facilities with low floor-to-floor heights.
- It is suitable for renovations where the introduction of new internal shafts is difficult.
 - Exterior shafts increase the planning efficiency and raise the grossing factor.

Disadvantages

- It is difficult to add utilities.
- The exterior appearance of the building is strongly influenced.
- Access for servicing is limited to the common wall between shaft and building.
- Piped services are subject to temperature differentials, so insulation of the shaft may be required.
- Flexibility of planning for future laboratory configurations may be reduced.

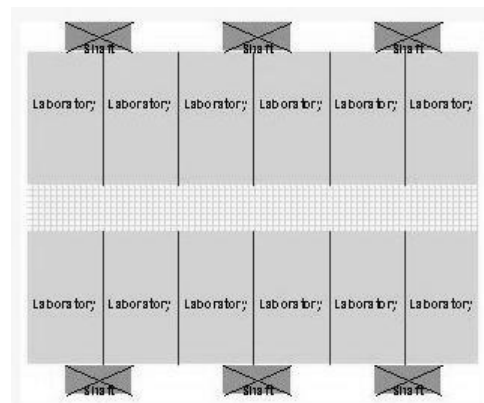

Figure 2. 60: Multiple exterior Shafts, source: NIH biomedical lab design guide

Service/Utility corridor

In this system, laboratory spaces adjoin an accessible service corridor which houses horizontal utility services above head height and distributes horizontally into the laboratories via the ceiling or directly to the lab bench through the wall of the service corridor. Vertical shafts for mechanical and piping systems are required at strategic locations. The service corridor should be a minimum of 1500 mm in width, plus any utility and storage areas. In a utility corridor distribution of utilities is provided through an internal dedicated corridor that accommodates maintenance staff access only.

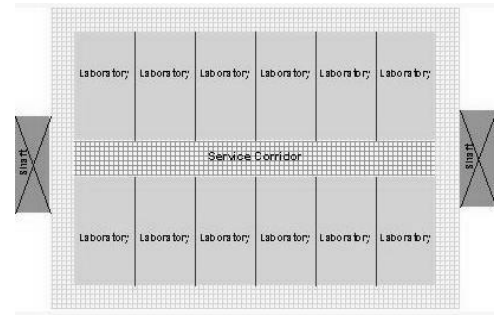

Figure 2.61: Service/Utility Corridor, source: NIH biomedical lab design guide

Advantages

- Continuous access for maintenance is available through the service corridor without entering research spaces.
- Shut off valves and electric panels are easily accessible
- Special zones in service corridors could house equipment that is objectionable in the lab environment due to heat, moisture, noise, and other products.

Disadvantages

- The planning efficiency is decreased, and the grossing factor is increased
- Building flexibility is limited
- If the service corridor cannot be made suitable for personnel circulation or egress, the plan will require additional circulation space.
- It is more difficult to provide direct natural light into the laboratory, unless there is only one double load service corridor per floor.
- During emergencies (chemical spills, smoke and fire situations, etc.) it is almost impossible to perform a thorough clean up due to inevitable storage in the service corridor.
- The width of the service corridor impacts greatly on emergency response, the wider the corridor the more material that will accumulate there.

Classroom

Sitting arrangement determines the shape and size of the classroom. The classroom should have the following:

- Front wall longer than the side walls.
- It is desirable to have 5 rows of 7 seats rather than 5 seats of 7 rows.
- Amount of space per student for seating in comfort is 70x65cm, and on average 60x8055x75cm. 0.6m² is needed per student including all spaces in larger lecture theatres.
- Smaller lecture theatres and in average comfort 0.80-0.95m².
- The angle of elevation from the eye to the upper part of the object on the screen or chalkboard should not exceed 30 degrees.

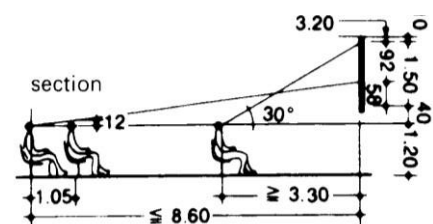

Figure 2.62: Lecture Hall, source: Neufert

Lecture hall for the school can be designed in the form of

- Assembly room: to combine large groups for professional lecture should be stepped in nature and provided with tables or desk chairs for visual efficiency. Space required per student= 1.2 Sq. ft.
- Small room: for seminar, conferences, informal discussions provided with movable table and chair. Armchair may be used. Space required per student= 1.5sq.ft.

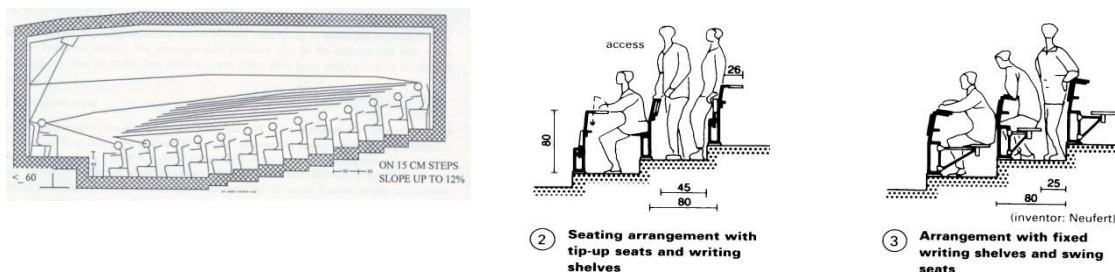

Figure 2.63: Lecture Hall design standards, source: Neufert

2.4 Water Quality in an Aquarium

The chemical condition of the water in which fishes and invertebrates are kept is vital to their health. Anything suspended or dissolved in the water comes into the most intimate contact with these animals, mostly through their gills, and there is little they can do to keep harmful substances from entering their bloodstream or body. For example, "only two parts of copper dissolved in a hundred million parts of water can kill some fishes within 24 hours, while acutely toxic concentrations of pesticides like Endrin need have a strength of less than one part per billion." The invertebrates are said to be even more sensitive than fishes. In order to keep those animals as sensitive and vibrant as alive while they are in captivity, there is only one safe rule to follow: all parts or all aquaria and water systems must be chemically inert i.e. built with chemically non-reactive or inert materials.

Table 2.10: Freshwater Aquarium water parameters, source: Pinterest

Parameter	Freshwater Community	African Cichlid	Freshwater Plants & Discus	Brackish	Pond
Temperature	72 - 82°F	72 - 82°F	76 - 86°F	72 - 82°F	33 - 86°F
pH	6.5 - 7.5	7.8 - 8.5	6.0 - 7.5	7.5 - 8.4	6.5 - 7.5
Ammonia	0.0	0.0	0.0	0.0	0.0
Nitrite	0.0	0.0	0.0	0.0	0.0
Nitrate	< 50 ppm	< 50 ppm	< 30 ppm	< 50 ppm	< 50 ppm
Alkalinity (Carbonate Hardness)	4 - 8 KH	10 - 18 KH	3 - 8 KH	10 - 18 KH	4 - 8 KH
General Hardness	4 - 12 GH	12 - 20 GH	3 - 8 GH	12 - 20 GH	4 - 12 GH

"The source of any water that is to be used in aquariums must be scrutinized to make certain it always has the proper chemical composition and never contains substances harmful to the exhibits. Ordinary standards of water purity are not adequate because perfectly potable fresh water or seawater, perfectly safe for bathing, may be deadly to fishes and aquatic invertebrates, as far as their water supply is concerned, these animals are much more delicate than man. Frequent troublemakers in municipal tap water are chlorine, excessive hardness, and brass or galvanized Piping. A single small metallic fixture can quickly bring about the death of fish when the water running through it is soft." (Chira, 1983)

Table 2. 11: Marine Aquarium water Parameters, source: reefaquarium.com

Element	Min	Max	Testing Frequency
Temperature	79F 25.6C	84F 28.9C	You will need to pick a exact temp based on the requirements of your stock and maintain a stable temperature to that requirement. I keep my tanks stable at 79F (only varying +/- 0.5F) and I will check it every day at least once a day by looking at the thermometer.
Salinity	1.025	1.026	Monitor at least weekly. Ensure you top up the water level for evaporation in the aquarium with only water (not salt water) as when the water evaporates the salt will remain. A stable salinity is also very important This is approx 35.5 ppt
Ammonia	0 ppm	0 ppm	Monitor daily while cycling your tank, then weekly until the tank has matured
Nitrites	0 ppm	0 ppm	Monitor daily while cycling your tank, then weekly until the tank has matured
Nitrates	0 ppm	5 ppm	Monitor daily while cycling your tank, then weekly from there on in. I prefer to keep my levels at 1 ppm or less
Phosphates	0 ppm	0.5 ppm	Monitor weekly once cycled. I prefer to keep my levels undetectable by a good quality test kit.
pH	8.0	8.4	Monitor weekly once cycled. Stability is the key
dKH	7.0	12.0	Monitor every few days once you start getting coralline growth or start adding corals. Once it is balanced with your Cal, test weekly and adjust by dosing supplements if required. I prefer my levels between 9.0 and 9.6
Cal	350 ppm	450 ppm	Monitor every few days once you start getting coralline growth or start adding corals. Once it is balanced with your dKH, test weekly and adjust by dosing supplements if required. I like to keep my Cal between 420 ppm and 430 ppm.
Mag	1280 ppm	1350 ppm	Monitor every few days once you start getting coralline growth or start adding corals. Adjust by dosing supplements if required. I prefer to keep my Mag level right at 1350 ppm

2.5 Water Systems in an Aquarium

The water system includes, totally or partially, the incoming water line, clarifying or sterilizing units (if required), storage reservoirs, the pipelines furnishing types and temperatures of water serving the display tanks, the display tanks, inflow and outflow and drainage, and filters.

Piping should always be of inert, nonmetallic materials. Water should not come in contact with metal until absolutely necessary. There are two types of water systems commonly used in aquarium systems.

Open System

Closed System

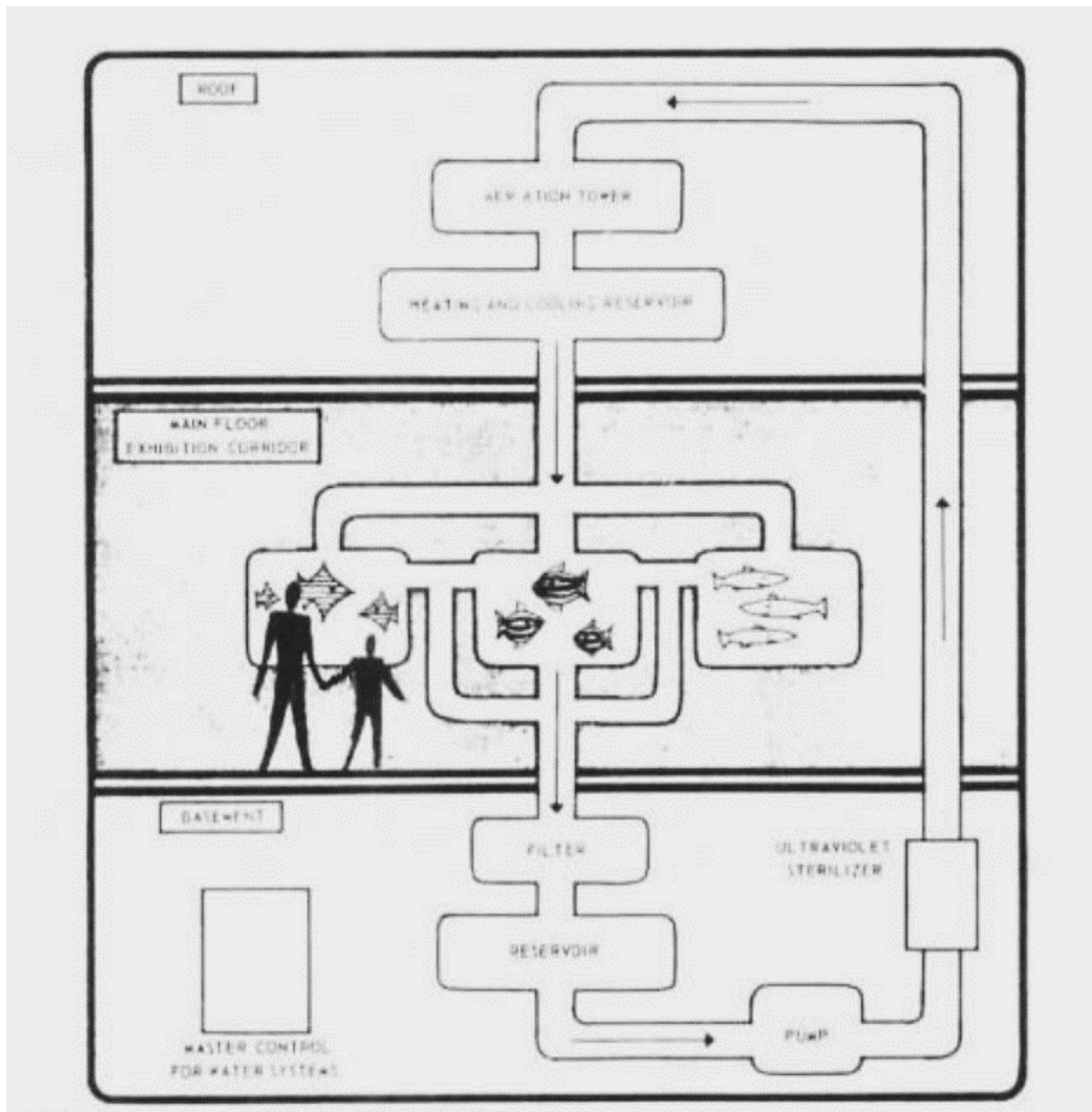

Figure 2. 64: Simplified diagram of Aquarium water system, source: Time-saver standards

2.5.1 Open Systems (use and waste):

This method is the easiest and least troublesome. This method is readily accepted as the water system if an adequate source of excellent and disease-free water is available near the site. previously stated condition of water not meeting metal may not be such a big problem in his, as the animals are exposed to water that has passed over the metal only once and the toxicity potential decreases due to the formation of inert oxides, etc. on the interior of metal pipes, which forms an insulation barrier, (corrosion is a factor that should be considered here). Economical condition of the aquarium is also to be considered if water is to be discarded after a single use, as this affair becomes expensive. "As a general rule of thumb, the average display tank or specimens loaded at the rate of 1 lb. of fish per 100 gal of water should have a turnover or replacement rate of one volume each one to two hours. If the gallonage of all display tanks

is 100,000 gal, a flow of 50,000 to 100,000 gal per hour would have to be maintained. Thus, 1.2 to 2.4 million gal would be required each 24 hours. An added cost would arise if some waters had to be heated or cooled." (Chira, 1983)

2.5.2 Closed Systems (recirculating total system):

In this system, water is continuously entered in the display tanks and the overflow is returned to the reservoirs after passing it through series of filters. Theoretically, only water lost due to evaporation or in the process of cleaning the tank or backwashing a filter is to be replaced in the tank. "However, seawater should be replaced at the rate of one-third of the total volume every two weeks, if possible." (Chira, 1983). Failing this, monitoring of nitrites, nitrates, and urea buildup becomes critical. One major thing to consider in a closed system is the very real possibility of disease- or disease-causing organisms present in one tank being carried to all other tanks. Filtration might not be much effective for most of them. The solution might be passing these waters through ultraviolet radiation or use of a reverse osmosis process. However, reverse osmosis process cannot be used in case of salt water.

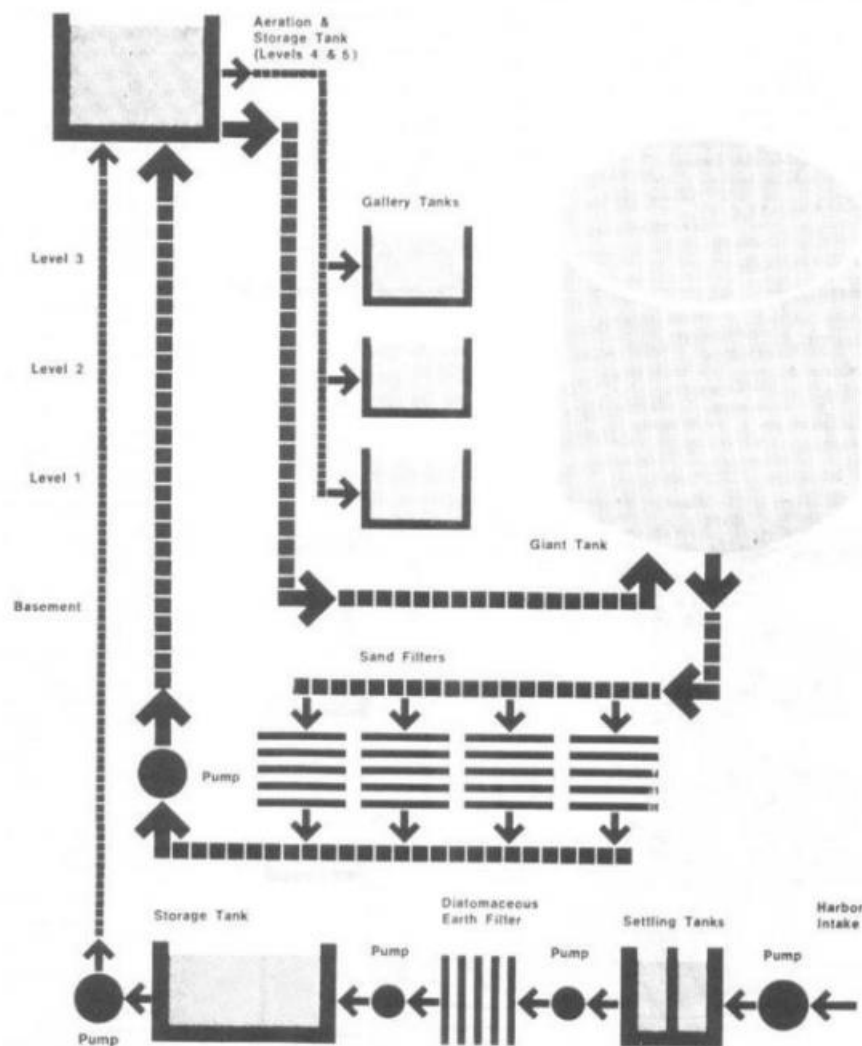

Figure 2. 65: Closed water system, source: Time-saver standards

Modern aquariums are highly efficient when they are using a closed system. In fact, due to its water conserving nature, most modern aquariums prefer closed system. Due to advanced recycling and filtration techniques, aquariums today can use its entire volume of water for a whole year, only exchanging small amount of water volume on a regular basis.

Thus, a 5-million-liter public aquarium would only use about 14,000 liter of water daily for exhibition purposes. In recirculation systems it is desirable to replace at least 10% of freshwater and at least 40% of saltwater each month to avoid a buildup of harmful substances. Usually great amount than this is replaced when the display tanks are regularly cleaned and filters backwashed. (Chira, 1983)

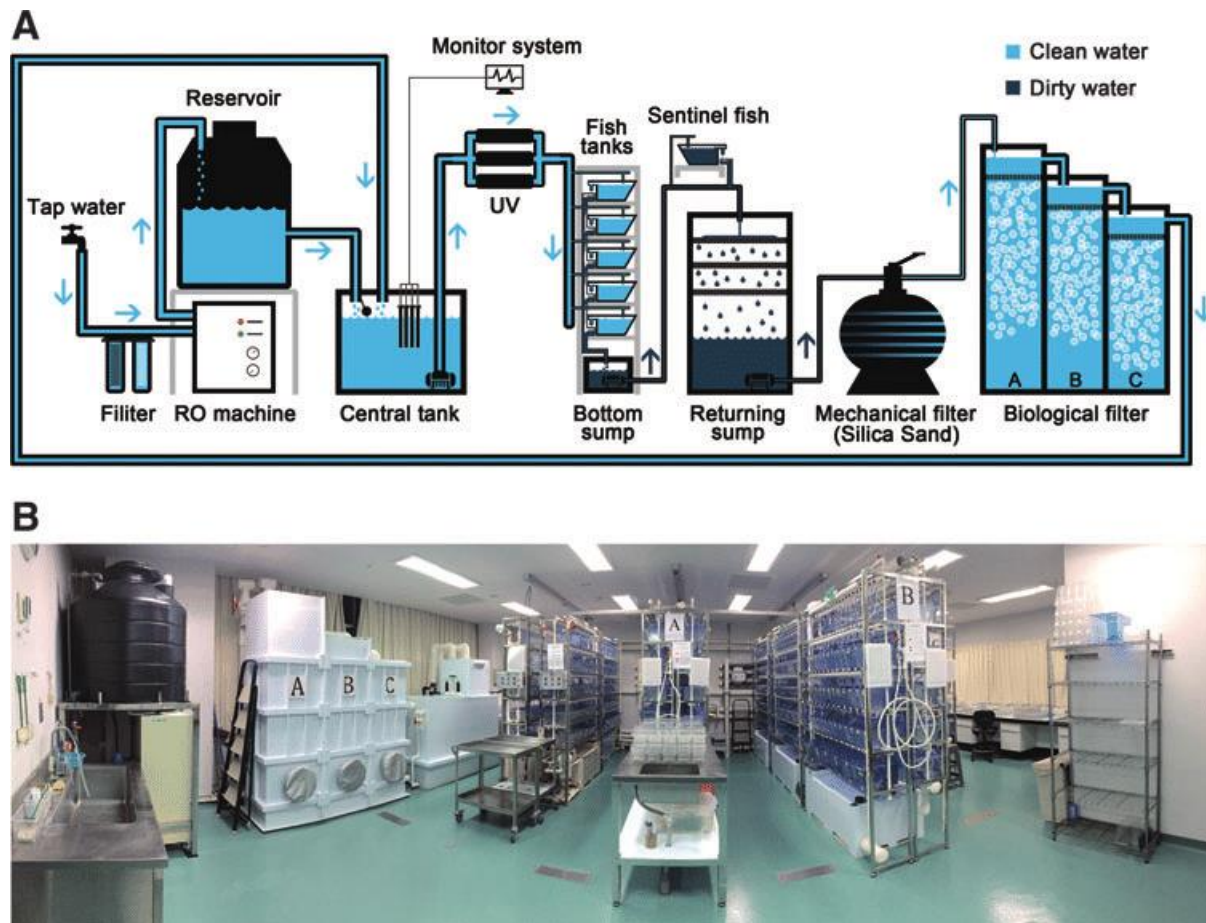

Figure 2.66: Modern aquarium water system, source: researchgate.net

2.6 Balanced System in Aquarium

Balanced aquarium is a naturally derived concept in an aquarium industry. The seas and oceans of world sustain the vast aquatic lives within itself by this process, without any external aid whatsoever. The concept of balanced aquarium promotes the sustainability of all the exhibits within the tank without any external interference.

As all the exhibits tend to produce waste matter within the enclosed space, elimination of those wastes becomes a major concern. In a balanced aquarium environment, these wastes are eliminated from the system by a simple action of reverse assimilation of waste. The waste of animals becomes food to the plants and vice versa. Besides plants and exhibit animals, nitrifying and denitrifying bacteria has a major role to play.

The major waste of aquatic animals is ammonia. Ammonia is highly toxic, highly soluble in water and very difficult to isolate from water. The only way to remove ammonia from water is by the action of bacteria which can change this highly toxic ammonia into less harmful nitrites and nitrates. These nitrites and nitrates are then used up by plants for their metabolic purposes or converted into free nitrogen and eliminated in atmosphere. Nitrogen cycle is a very important part in maintaining a balanced aquarium.

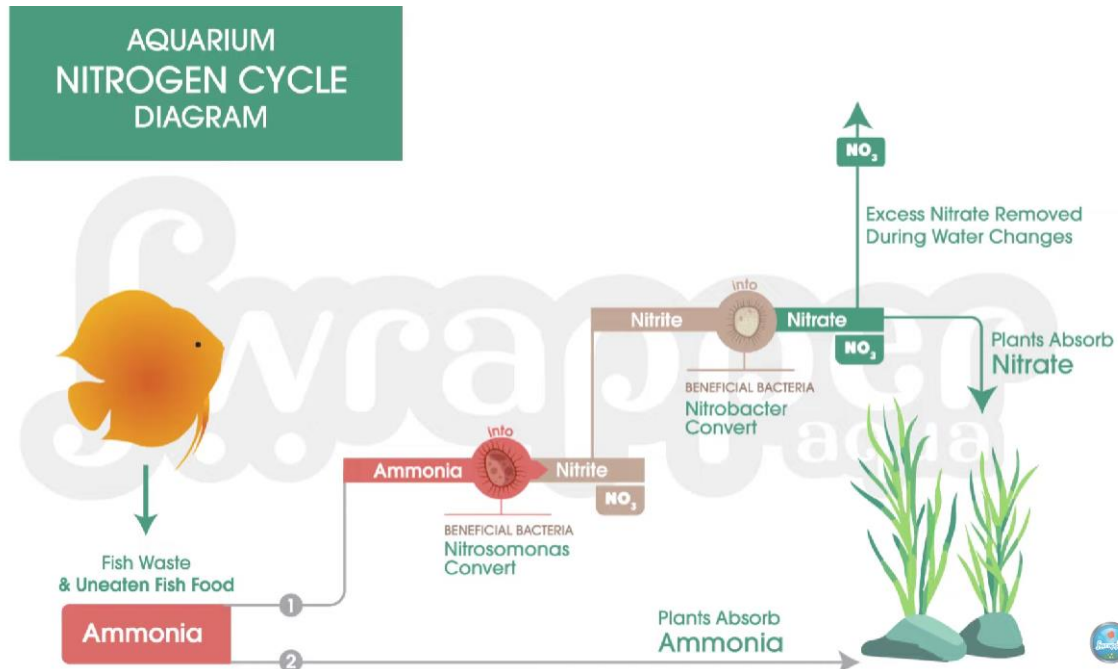

Figure 2. 67: Nitrogen cycle in an aquarium, source: yarmama.com

However, maintaining a balanced aquarium in a simulated environment is easier said than done. The exact amount of waste elimination and exact amount of bacterial volume can never be controlled in a desired manner. Thus, in a simulated aquarium environment, a life support system is to be provided to ensure eliminate the waste from the system and safety of living beings in the tanks.

2.7 Life Supporting Systems in an Aquarium

Life support systems in a public aquarium consist of various equipment and specialized mechanical devices that accumulate, circulate, recollect, and treat the water for re-circulation purposes. All the devices must be carefully procured or designed according to the need, size, and budget of the aquarium. As life support systems are the major consumers of energy in any aquarium, careful planning, optimum design criteria and proper maintenance of the life support systems become very important. Failing in which, aquarium might have to face a massive energy crisis which may have fatal consequences for the live exhibits residing in the aquarium's exhibition tanks.

The life system support system of any public aquarium should be automated and controlled by a network of computers as there is a very high margin for error while performing tasks manually. The system must contain of inbuilt alarms that may identify the errors at any point of the automated system and notify the maintenance staff about any malfunction such as pressure difference, leakage, unwanted suspended impurities etc.

Some of the major components of the life support systems are as follows:

2.7.1 Plumbing

Plumbing and pipeline are the lifelines of any aquarium. They circulate the water from the water storage tanks to the exhibition tanks and re-circulate the water from exhibition tanks to the filtration galley and recirculate the water to the exhibition tanks. As public aquarium deal with various types of water such as cold-water, warmwater, marine water, fresh water; brackish water etc. there can be a huge network of piping throughout the operations area. To avoid confusion among the plumbing lines, the lines must be appropriately labeled or color coded.

The various main supply pipes from the reservoirs should extend around the aquarium over the display tanks. These should be a minimum of 7 ft above the work-area floor and should have frequent tap valves from which, by flexible hose, replacement water or a continuous flow may be fed to the tanks, depending upon the system. It is important to have shutoff valves conveniently located along the major supply lines to facilitate plumbing repairs. To reduce the possibility of accidental flooding to a minimum, automatic cut-off switches, built-in overflow drains, and failsafe devices should be planned in connection with tanks and reservoirs that are periodically drawn down and refilled.



Figure 2. 69: Behind the scenes at Georgia Aquarium, source: aquanerd.com

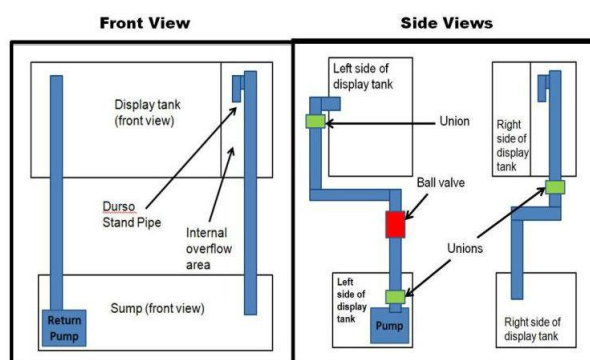

Figure 2. 68: Aquarium Plumbing, source: reefaquarium.com

Among a wide variety of materials used for aquarium piping the most used are the unplasticized polyvinyl chloride (uPVC) and the acrylonitrile butadiene styrene or ABS (Hawkins, 1981). They are both strong, easy to mount, low toxicity and not corrosive materials. Due to smooth bore resistance, flow is kept to a minimum. However, care must be taken to prefilter the water so as to prevent fouling. Easy dismantling is important for replacements and general maintenance. The valves used in the aquarium piping systems are mainly ball valves, but also diaphragm, butterfly and needle valves are used. When ball valves open allow full bore flow, but the flow control is difficult to be achieved. Needle valves are the best for flow control but show the highest resistance to flow. Non return and foot valves in the system are necessary to avoid line draining should cessation of pumping occur. (Karydis, 2011)

2.7.2 Filtration

Filtration is mostly carried out with the help of sand filters and protein skimmers, designed, and maintained in the operational areas. For larger tanks, Plenum filters equipped with bio filters may also be used.

2.6.2.1 Sand Filters:

Sand filters are often found in home swimming pools, just on a much smaller scale. The sand filters in public aquariums have much powerful (more than 1 000 times powerful) filtration power than the average swimming pool pump. As the unfiltered water flows from the Aquarium, pumps push water down through the sand in filters which catches dirt and debris larger than 20 microns. The filtered water flows through the filter and back into the aeration Tower which gravity feeds back into the Aquarium at low velocities.

2.6.2.2 Protein skimmers:

Protein skimmers simulate a process found in nature used to rid the water of waste. In nature, air bubbles are formed by crashing waves which create foam and carry waste out of the water on the surface tension of the bubbles. In the Aquarium, the protein skimmers create those air bubbles and foam through air injection and clean the water through the same principal.

2.6.2.3 Aeration chambers:

Aeration towers are responsible for maintaining the required volume of dissolved oxygen (DO) in the water. By passing a jet of air through these chambers filled with water, proper exchange between oxygen and carbon dioxide can take place and dissolved oxygen level can be maintained. Aeration of the water can be done individually in the tanks as well by the same process.

2.6.2.4 Water Heating and cooling:

The heating and cooling capabilities of the building are designed to maintain tight water temperature parameters in the exhibits to within tenths of a degree Fahrenheit. This is necessary to provide top of the line care for the Aquarium's many aquatic inhabitants.

Further different filtration systems are:

Mechanical filtration: In modern aquariology the term “filter” means at least four different things: straining, sedimentation, chemical bonding, and biological degradation. Filtering requirements should be considered cautiously: they are a costly procedure; they need very good maintenance and can also raise many problems referring to anoxia and bacterial contamination under careless operating conditions.

Straining refers to mechanical filtration; it can take place at the water intake or along the pipelines before the pumps, for the removal of coarse material such as sand and small gravels. This stage is important not only to improve viewing conditions in the display tanks but also to protect mechanical equipment from serious damage. The most usual type of mechanical filters is the cartridge filters. They are commercially available as they are used in swimming pools. Cartridge filters can be easily inserted directly into the water circulation systems and can be replaced on a routine basis. If high flow capacity is needed, multiple filter systems can be used in parallel arrangement. There is a wide choice in sizes, materials, and filtration performances so the aquarium staff should make the right choice considering the quality of the seawater at the pipe intake, the volume to be treated per hour as well as the water quality requirements in the tanks. The system of mechanical filtration needs good maintenance: disposable cartridges

should be replaced regularly, whereas permanent filters need frequent back flushing. Sand filters are the commonest filtering system in public aquaria. The sand used for filtering is characterized by the grain size, grain shape, specific gravity, and grain distribution. The lower limit of sand media is about 20 μm and the filtering action occurs in the first few centimeters. (Karydis, 2011)

Biofilters: Chemical bonding and biological filtration are more delicate and expensive processes; they are recommended only for closed circulation systems. A closed system supported by biological filtration can be an independent subsystem in the aquarium if special conditions such as high temperature are required for keeping tropical fishes. In addition to particulate organic material, dissolved organic compounds also need treatment. The aquarium organics are mainly metabolic wastes; their quantity depends on the total biomass, feeding practices, the characteristics of different foods used, the water temperature as well as the assimilation efficiency of the animals. If solid wastes are removed by mechanical filtration or sedimentation what is left in the seawater is ammonia, nitrite, nitrate and dissolved organic compounds. These organics can be toxic to the captive animals depending on their concentration, the different species, the life stage of the organism and the environmental conditions. In addition, accumulation of nitrogenous compounds will gradually establish eutrophic conditions in the tanks. The treatment of these compounds requires biological filtration. The process that either removes nitrogen from the aquarium or converts it to fewer toxic compounds are called mineralization, nitrification, dissimilation, and assimilation. Biological filtration converts ammonia and nitrite into nitrate.

Aquatic organisms can tolerate nitrate concentrations up to 200 mg. Nitrate beyond being toxic, is associated with growth of microalgae that settle on the aquarium glass fronts as well as with inhibition of coral growth in marine aquaria. This means that even for a recycling system, gradual water replacement is necessary. A flow though varying between 5 and 10% of the water volume per day is adequate in aquaria to keep nitrate concentration low. The complete oxidation requires 4.57 mg of oxygen per mg of ammonia nitrogen therefore the oxygen demand should be considered.

Recently an ion exchange bioreactor has been proposed that converts accumulated nitrate into molecular nitrogen. This system was applied in a public marine aquarium and allowed the removal of nitrate at concentrations of 251 to 380 mg down to about 27 mg exchanging it for chloride. High nitrate concentration can also affect the pH of sea water, shifting to lower pH values. Nitrification takes place in a separate container called biofilter. Biofilters are usually submerged and is preferable for the water flow to take place downward. (Karydis, 2011)

Foam fractionation: Air bubbles are introduced into the water column. As the bubbles raise, a skin of particulate and dissolved organic compounds surrounding the bubbles, form a foamy water between the air and water interface. The foam produced is collected and removed to the drain. Foam formation depends on organic load, chemical composition of the compounds, air – water ratio, surface tension, temperature, viscosity, pH, bubble size and control time. The optimal bubble size diameter is 0.8mm. Foam fractionation is also known as protein skimming, air stripping and froth flotation. (Karydis, 2011)

Activated Carbon: An alternative method to remove dissolved organic carbon from the aquarium water is to use activated carbon either in powder or granular form. It can absorb

organic wastes and some trace elements such as copper. Carbon is efficient at low concentrations of organic matter, and therefore it is preferable to be used at a “final polishing” stage in the water treatment procedure to remove persistent non-biodegradable organics. The carbon performance depends on the composition of the organics adsorbed, contact time, concentration of organics, biological films on the carbon, particle size, pore surface area, selectivity, temperature, and pH. Although activated carbon can be regenerated, the adoptive capacity becomes less and less by the time. It is an expensive method for treating water and it should be applied only, if necessary, at the final stage of water treatment.

2.8 Acoustics in an Aquarium

Architecture for aquariums can also include acoustics. Large amounts of water are dealt, and the running water starts to produce a lot of noise. But whenever tourists go to a public aquarium, they expect finding a calm, serene setting where they can watch various aquatic species swim and float wonderfully and feel their stress melt away.

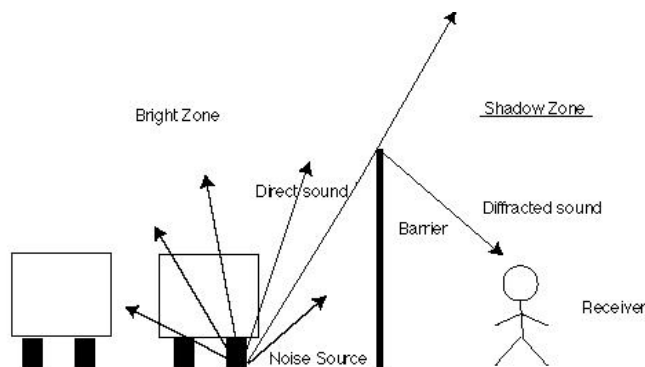

Figure 2. 71: Sound Barrier, source: acoustics.org



Figure 2. 70: Sound Dampening Pad, source: aquacave.com

Knocking on the glass front of aquarium exhibits is a considerable disturbance for resident fish. The knocking behavior of visitors was recorded, and the effect of signage in reducing this behavior was experimentally tested. Knocking occurred at a rate of nearly two knocks per 100 visitors during baseline recording. Three different information signs achieved a reduction of this behavior by 10, 18, and 28%, respectively. The addition of protective glass panes may be required to further reduce the acoustic effects of knocking in the case of highly sensitive fish species. (Kratochvil, 1997)

To maintain this serenity within an aquarium, the noise in the maintenance areas through water pumps, maintenance staff and other factors should not reach the exhibition galleries. The said exhibition gallery also must remain free of noise in multipurpose halls, cafeteria, vehicle parking, loading, and unloading docks etc. A lot of work goes into making a quiet aquarium. A few of them have been listed below.



Figure 2. 72: Aquarium Filters as noise producers, source: asfilters.com

- Wherever it is feasible, cavity wall construction can be done. Noise is muffled by the space between the two levels of the wall. The cavity wall might be filled with noise cancelling materials such as glass wool and Styrofoam.
- In the service areas, vibration-dampening panels may be used.
- Padded walls and covered heavy machinery can be used. Heavy machinery is wrapped in a thick layer of padding to reduce noise.
- Acoustic treatment of all the parts of the services area also becomes necessary.
- It also becomes vital to consider the acoustics of every component of the services area. Walls, floors, ceiling doorways or any other puncture in the walls must be acoustically treated.
- Automatic sound-proof doors must be used to divide the maintenance facilities from the display space.
- Similarly, Acoustic treatments should also be done in the exhibition galleries to make it free from noise arising in the amenities such as cafes and parking.

2.9 Lighting in an Aquarium

Lighting is a very important part of any building. A building that is too bright feels uncomfortable to be inside, a building that is too dark makes you miss things. Light clues guide people. The right amount of lighting can move people around the building showing them where they should go and what they should see.

In any public aquarium, natural light should be avoided as far as possible in all the gallery spaces. The natural sunlight promotes in algae growth in the exhibition tanks, causing hindrance in views for the visitors. Thus, highly efficient artificial lighting should be done in the gallery spaces of the public aquariums. If the exhibits require special need for natural light (e.g., Aquatic plants for photosynthesis), similar type of artificial source should be provided that does not aid in unnecessary growth of the plant material, causing maintenance problems.

"Lighting for aquatic animals shall be sufficient for the needs of the animals, by natural and / or artificial means, and of a quality, distribution and duration, which is appropriate for the species involved. Sufficient back of house lighting must be available to provide uniformly distributed illumination, which is adequate to permit routine inspections, observations, and cleaning of all parts of the area and life support systems. Lighting design should be considered to avoid overexposure and excessive illumination of aquatic animals." (*EHS Modern Public Aquarium Regulations, 2008*)



Figure 2. 74: Lighting in Display area, source: asablo.jp



Figure 2. 73: Gallery Space with proper lighting, source: archdaily.com

While lighting galleries, it must be seen that the galleries are only just sufficiently lit. Galleries should not be brightly lit as the main source of light should be the light inside the aquarium tank. This will avoid any unnecessary glare and reflections occurring through the surface of the tanks.

It is best if the aquarium is lit from the top front. Lighting from behind can result in needless silhouetting, whereas lighting from the side angles is known to stress fish species unnecessarily. Thus, lighting an aquarium from the top front helps to make aquarium viewing much more interactive and less distracting to the public viewers.



Figure 2. 75: Top lighting, source: orphek.com

The concept behind just sufficiently lit circulation galleries is “Putting brightly lit objects in dimly lit room”, which would help properly focus on that what we are trying to showcase in our project. Average gallery to tank brightness can range anywhere from to 1:2 to 1:5.

Artificial Saltwater:

Public aquariums are typically located in coastal areas where there is ready access to fresh seawater. But recently, more facilities are opening in cities nowhere near the coast, Thanks to advances in technologies to make and filter artificial seawater, even people in landlocked cities can experience the vibrantly colored fish and the dolphin shows that aquariums offer.

"The availability of artificial seawater is what allows aquariums to be built in even inland cities," Anonymous public-relations staffer, Sumida Aquarium. Japan

It's now possible to make artificial seawater in a very efficient way. Located in urban areas, these aquariums can attract people who would otherwise need to make a day trip out of visiting an aquarium.

Artificial seawater is made by dissolving several different chemical compounds into water to replicate the composition of natural ocean water. The mixture includes sodium chloride, magnesium sulfate and calcium chloride, but it does not include everything found in real seawater.

For marine animals like dolphins that breathe air, the recipe for seawater does not need to be strictly followed like it does for fish. In fact, many facilities use just sodium chloride for the water.

It is generally assumed that natural seawater containing plankton and trace components is more appropriate for fish and marine animals in captivity. But some argue that artificial seawater has benefits because it does not contain pathogens and pollutants. (*Kusashio, 2012*)

Best practices of Aquarium design:

- Implementing interactive exhibits and touch tanks
- Showing the local ecology

- Relating building and landscape
- Creating public spaces that provides quality, amenity, and flexibility.
- Providing a dynamic, year-round destination.
- Integrating well with the surrounding urban fabric
- Support activity at the waterfront.

2.8 Universal Design

According to National Building code of Nepal NBC 206:2003 provision must be made for the specially challenged person such as access to all parts of the building and the site as well as for latrines. The author is of the opinion that designer must do more than just meet the minimum design criteria and allow more inclusiveness rather than segregation and innovative solutions in their design to make it easier and comfortable for specially challenged people. Apart from following the national building code, research buildings must also adopt internationally followed standards that are unique to laboratory buildings. There are many design features that must be adopted but only a few important ones will be discussed.

2.8.1 Ramp

Ramp is a sloped surface designed to connect two spaces at different height and are often constructed either instead of, or in addition to stairs/steps to make the spaces accessible.

The following parameters should be considered:

- Recommended slope of ramp is 1:20. Steeper slopes may be allowed in special cases depending on the length to be covered (refer figure 2.1.5-a).
- 1,800mm is the preferred width of ramp. 1,500mm is the minimum to be provided with an unobstructed path of minimum 900mm.
- Landing of size of equal or greater than width should be provided after every 14m of horizontal run for a 5% slope. (Settlement)

Table 2. 12: Relationship between slope of ramp and running length of landing

Maximum slope	Maximum running length (m)
1:20 or 5%	-
1:16 or 6%	8
1:14 or 7%	5
1:12 or 8%	2
1:10 or 10%	1.25
1:08 or 12%	0.5

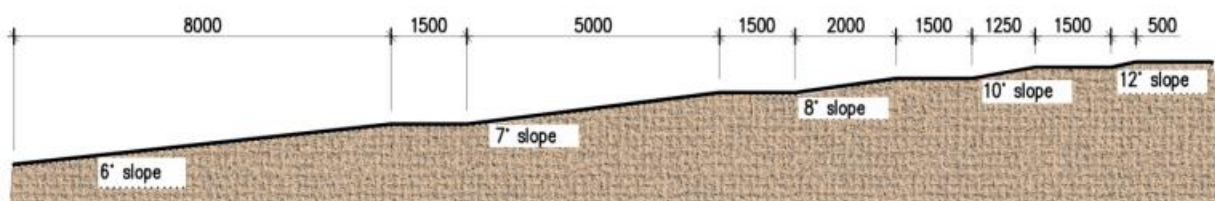

Figure 2. 76: Consideration for ramp

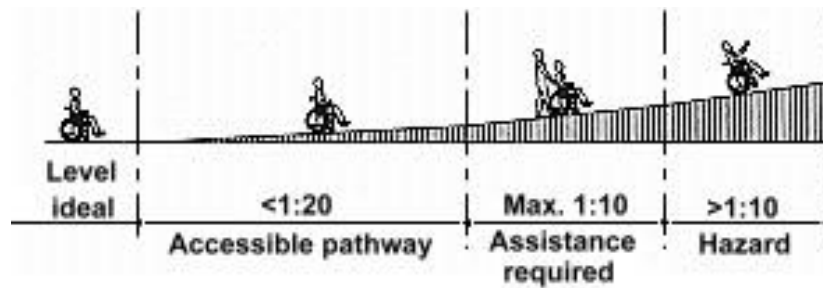

Figure 2.77: Ramp gradients, source: Neufert

2.8.2 Parking

Parking lots are defined spaces in a built environment to park vehicles along the roads or in spaces designated for Differently abled people with space consideration and proper signage.

The following parameters should be considered:

- Outdoor parking should be maximum 50m away from accessible building entrance and indoor must be next to the accessible elevators or exit.
- If the parking space provided exceeds 50 parking bays, provide one accessible parking space for every additional 50 parking spaces.
- Drop-off areas should be located no less than 30m from the accessible building entrance.
- Provide at least 3,200mm wide drop-off zone with aisle of 1,500mm for ease of maneuvering.
- Use tactile flooring of at least 600mm wide at the edge of the pathway to warn pedestrians of the transition to vehicular space.
- Use proper signage for drop-off zone and parking for clarity and information.
- Do not locate parking space at the entrance to a building or a facility. (Settlement)

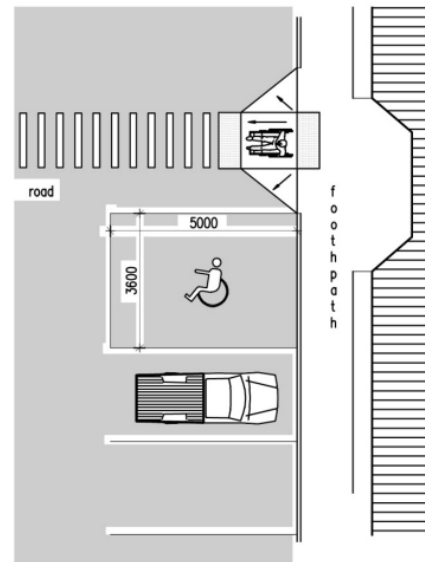

Figure 2.78: Parking Consideration

2.8.3 Entrance

All interior routes from accessible entrances to accessible exits should be safe and easy to use by differently abled persons. Such routes should be clearly identifiable and logical in layout.

The following parameters should be considered:

- The main entrance should be clearly identifiable and obstruction free.
- The footpath should lead from the drop-off zones or parking lot to the entrance to the building.
- The entrance to the building should be provided with tactile flooring.
- Both stairs and ramps should be provided to enter the building with handrails on both sides. (Settlement)

2.8.4 Toilet Design

The following parameters should be considered:

- 1) The ease of transferring from a wheelchair to a toilet seat or bidet depends on the approach. In general, there are four different approaches. The four approaches are:
 - a) The parallel approach, the easiest,
 - b) The diagonal approach, the difficult,
 - c) The perpendicular approach, the difficult and,
 - d) The frontal approach, which is the most difficult and need particular care.
- 2) At least one toilet accessible with a wheelchair for one user in institutional buildings or one toilet for every hundred users, should be allocated.
- 3) The distance between the centerline of the washbasin and the adjacent sidewall should be at least 450mm.
- 4) No shelves should be located above the washbasin.
- 5) Washroom accessories such as paper towel dispensers, soap dispensers, waste bins, and others should have all controls, operating or dispensing components mounted no higher than 1,200mm from the floor.
- 6) Urinals should have a clear space on both sides.
- 7) A full-length urinal is the most accessible.

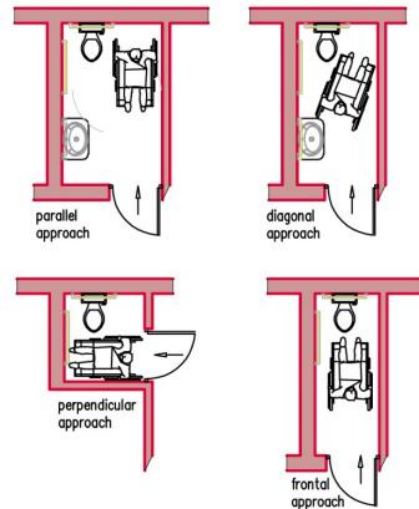

Figure 2. 79: Toilet design for special population

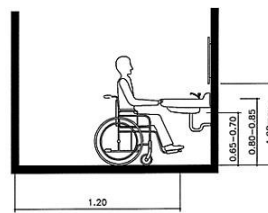

Figure 2. 81: Sink design for special population

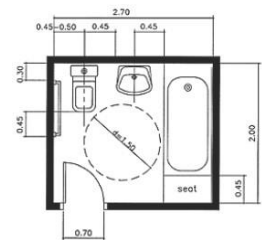

Figure 2. 80: Toilet design for special population

2.8.5 Circulation

The table below gives the minimum clearance needed for circulation based upon the turning radius of the wheelchair which is 5”.

Table 2. 13 Clearance for wheelchair, source: Time-saver standards

SPACE	DIMENSION
Door	34”
Aisle	48” min.
Turn Clearance	60”

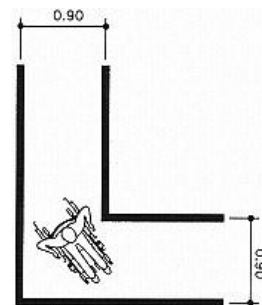

Figure 2. 82: Turning for wheelchairs, source: Neufert

Steps

Steps are provided on a footpath to accommodate level differences. Steps with proper design and features should help Differently abled person to overcome obstacles in transition of spaces.

The following parameter should be considered:

- The external steps should be between 3 steps in a flight and not exceeding 10 steps in a flight.
- The steps should be uniform in size along its flight.

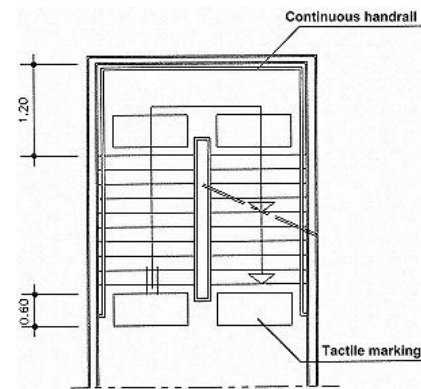

Figure 2. 83: Staircase for universal design, source: Neufert

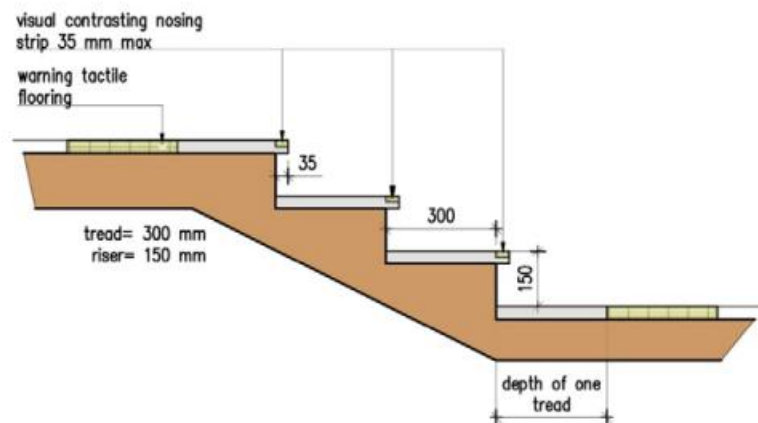

Figure 2. 84: Considerations for step

2.9 Disaster management

The greatest risks to aquarium building should be identified and procedures should be set in place to plan to reduce the effects of unavoidable disasters. Preparations must be made to respond in the case of a disaster — whether natural or manmade. Disaster can be Floods, Fires, or Earthquakes.

The most common risks to museum collections include:

- Physical forces (earthquakes, physical damage from staff, vibrations from drawers, repair work)
- Fire (flame, soot)
- Water (floods, plumbing or roof leak)
- Criminal (robbery, isolated theft, vandalism)
- Pests (rodents, insects)
- Contaminants (dust, gasses)
- Light and UV radiation
- Incorrect temperature

- i. Incorrect relative humidity
- j. Custodial neglect (data loss, misplacement, sample mixing)

Nepal government policy in terms of disaster management

- Natural calamity act 1982-regional, district, local DRC
- Local governance act (LSGA)- 1999
- Interim plan (2007-2010)-separate chapter on DRNI

a. Fire proofing materials:

Inorganic methods of making materials or structures more resistant to fire include:

- Gypsum plasters
- Cementitious plasters
- Fibrous plaster application
- Structural steel to keep below critical temperature ca. 540 °C
- Electrical circuits to keep critical electrical circuits below 140 °C so they stay operational
- Liquefied petroleum gas containers to prevent a fire

b. Fire walls

A firewall is a fire-resistance rated wall assembly intended to slow the spread of fire from one side to the other constructed of gypsum board partitions.

c. Fire Hydrant

- Active fire protection measures
- Source of water provided in most urban, suburban, and rural areas with municipal water service to enable firefighting

d. Water sprinkler system

A passive fire protection measure refers to the act of making materials or structures more resistant to fire.

e. CO₂ fire extinguisher system

Reduces oxygen content in air.

f. Escape Route

Horizontal escape route:

No. of escape route depends upon distance to exit, construction and protection of fire routes, protected hallways (1/2 hr fire resistance), provision of doors (smoke proof door), construction of escape stairs (fire resisting materials), final exit, lighting and signing.

Vertical escape route:

Protected escape stairs of sufficient number and size depends upon no. of people and no, of floors.

Earthquake:

With huge number of waters in any public aquarium, public aquariums can be very earthquake prone. However, measures can be taken to make any aquarium earthquake resistant.

- Placing larger tanks in the lower floors
- Water tanks must be always filled more than 50%
- Water tanks should not be left open, wherever possible
- Feature of rapid draining of water must be inbuilt in the plumbing systems.
- Base isolation of tanks should be done wherever possible
- Special structures should be designed for water retention systems.
- Large tanks must be separated in buildings from each other using expansion joints.

2.10 Rainwater Harvesting

Rainwater harvesting (a step towards water conservation) is the technique of collection and storage of rainwater at surface or in sub-surface aquifers before it is lost as surface run-off. Rainwater can further be used for artificial recharging of ground water. It is a process by which the ground water reservoir is augmented at rate exceeding that under natural conditions of replenishment. Rainwater harvesting overcomes the inadequacy of waters, helps maintain water levels. It increases infiltration of rainwater in the subsoil which has decreased drastically in urban areas due to paving of open area and improves ground water quality by dilution. Further, it improves ecology of the area by increase in vegetation cover.

Pokhara has a great potential for Rainwater Harvesting which is made clear by the calculation below:

Annual rainfall: 3.34m considering-120 rainy days

Run-off coefficient: 0.8

Annual water harvesting capacity of 100m² area = $100 \times 1.61 \times 0.8 = 267.2 \text{ m}^3$ = Annual water demand of 15 persons (50L/p/d)

3.0 Case Studies

3.1 Central Zoo (Aquarium)

3.1.1 Introduction

Location: Jawalakhel, Lalitpur.

Building Type: Recreation Space

Aim: Aquarium

The Central Zoo, the only zoo in Nepal, was founded essentially as a private zoo by the late Prime Minister Juddha Sumsher Jung Bahadur Rana in 1932. In 1956, the zoo was formally opened to the public by the government of Nepal.



Figure 3. 1: Central Zoo Masterplan

3.1.2 Layout

The zoo's end is where the aquarium is. The aquarium has a straightforward design, with the display tank and a small filtration system in the back. The nearby storage tank is also accessible. The air pump, heater, and filter for the display tanks work continuously.

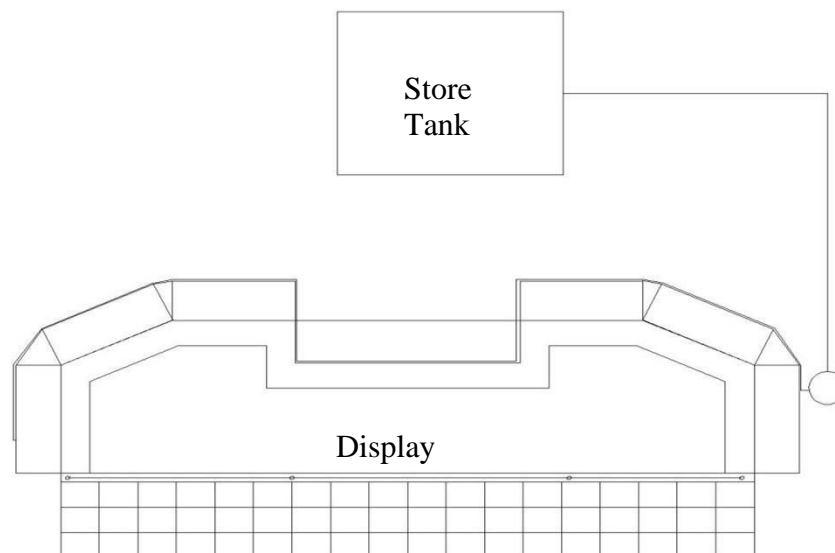

Figure 3. 2: Display tank Plan

Filtration

There are three forms of display. 1100, 1600, and 2100 liters. The tanks are set up symmetrically. The 1600 lt. tank contains a variety of cichlids, including the Silver Cichlid, Oaxaca Cichlid, Redheaded Cichlid, Coatzacoalcos Cichlid, and Black diamond Cichlid. The 1100 lt. tank contains Red Parrot Fish, Oscar Black and White, and the fish. 2100 lt. tank contains Pacu and Alligator Gar. Periodically, a brush is used to clean the display from the top. A cover is included with the display and can be removed for feeding and cleaning.

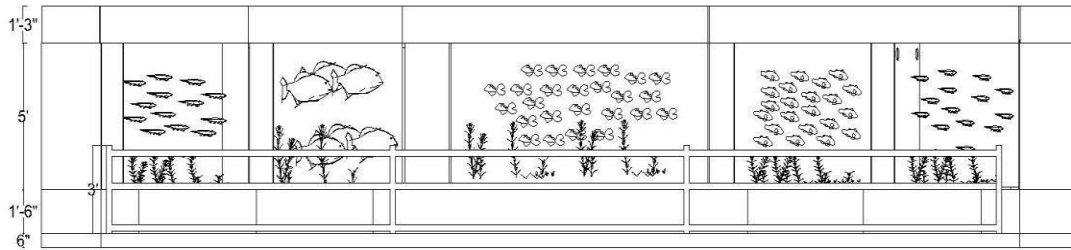

Figure 3.3: Elevation of Aquarium



Figure 3.5: Display tanks



Figure 3.4: Display tanks

3.1.3 Filtration Process

The aquarium at the zoo is filtered using a straightforward procedure. The number of the display's air pump, heater, and filter is given in accordance with the tank's capacity; for example, a 2100-liter tank includes two of each of these items.

It consists of a tank for storage and a vessel for filtering with charcoal at the bottom and fiber at the top. The filtering procedure immediately connects the pipes to the full display tank. The filter is connected to the store tank via pipes that go beneath.

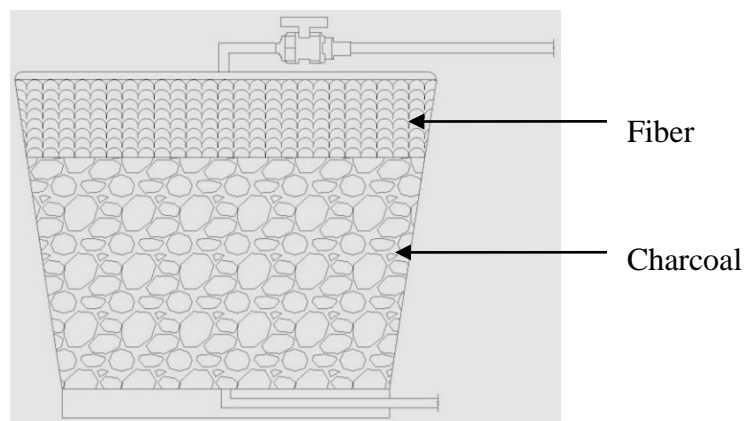

Figure 3.6: Filtration Plant

As the water in the display is reduced the water from the store tank is used to fill the reduced level after filtration. The water from the store tank is flowed through the filtration which passes through charcoal and fiber and then it is supplied to different display for about 1 hour in each tank. The fiber and charcoal are changed in every 2 years.

3.1.4 Summary

- The Aquarium being the only one in the central zoo has very less variety of species.
- The people are seen crowded in the aquarium part, but the aquarium scale is too small to fulfil the demand of the people.
- The aquarium lacks the space for providing knowledge about the species.
- The safety measure to be undertaken is not considered.

3.2 National Botanical Garden

3.2.1 Introduction

Location: Godavari, Lalitpur

Building Type: Recreation Space

Area: 82 Hectares(1611.83 ropani)

Aim: Conservation of Flora and Recreation Center

The National Botanical Garden at the Godavari established in 1962 AD. has been functional in conservation of rich flora and fauna of the country for four decades. It is also a recreational place for public. It is located at the base of Phulchowki Hill approximately 16km southeast of Kathmandu Valley. The garden spread over 82 hectares have temperature range between 20C and 30C during summer and 5C to 20C during Winter. It is perhaps the best botanical garden in the country to collect and preserve the adequate representation of Plants from all around the country.

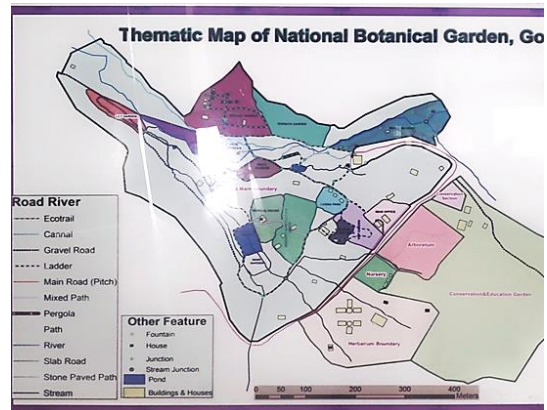

Figure 3. 7: Botanical garden Plan

3.2.2 Layout

The garden can be broadly classified into three major functional area:

- a. Conservation and Education Division: It focuses on conservation of gardens through glasshouses and garden. The glasshouse is not much functional.
- b. Commercial Division: It focuses on Sale and generates income for sustainability of gardens.
- c. Garden development section: It focuses on landscape design of the area and maintenance.

Special Features:

1. Main Garden Office
2. Botanical Information Center and Exhibition Center
3. Physic Garden
4. Special Garden
5. Orchid House
6. Cactus House
7. Terrace Garden
8. Fern House
9. Japanese style Garden

- 10. Lily Garden
- 11. Rock Garden
- 12. Tropical House**
- 13. Aquatic Garden**
- 14. Rose Garden
- 15. VVIP plantation area

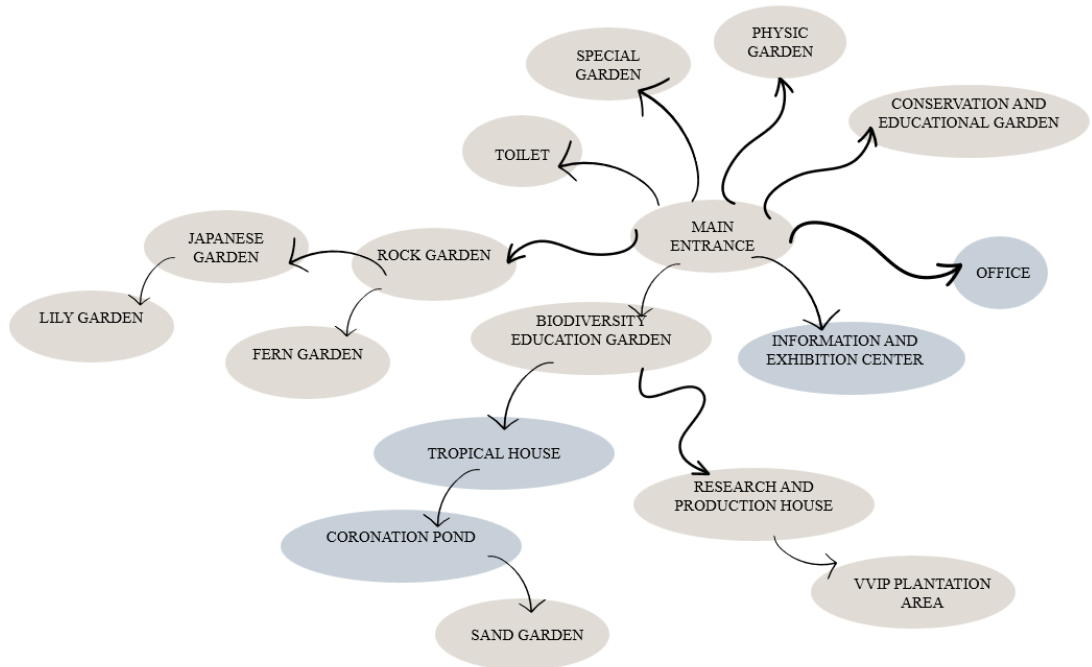

Figure 3. 8: Bubble diagram of Botanical Garden

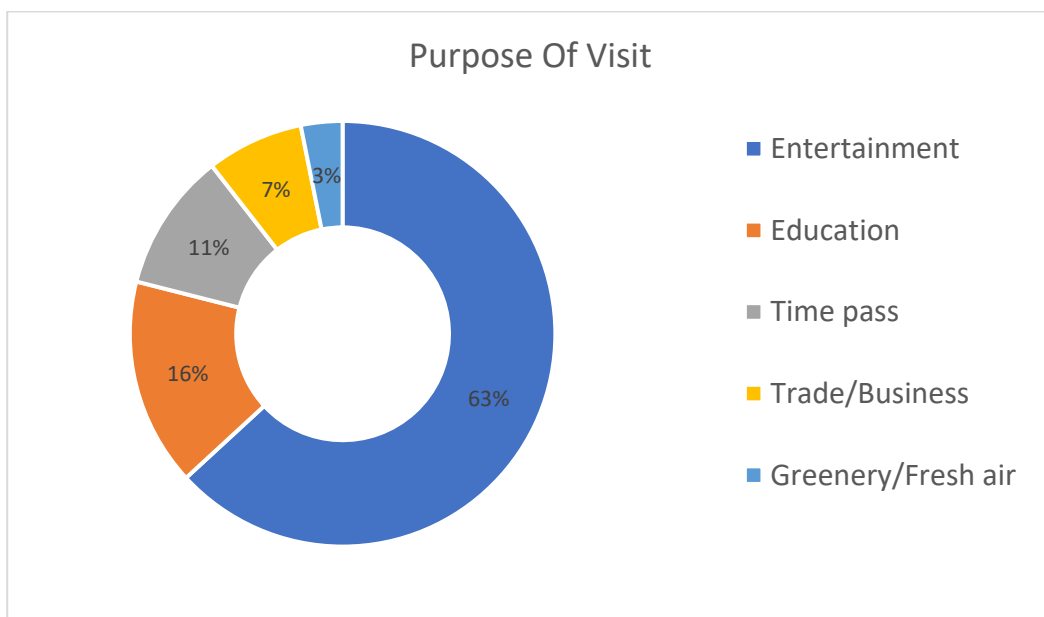

Figure 3. 9: Purpose of visit of people in Botanical Garden

a. Main Garden Office

The main garden office is located outside the botanical garden and manages the whole garden. The current garden office building is an old residential building that has been used for office purpose. Thus, lack of proper office amenities and environment. The total number of staff currently working at office is 40 including technical and administrative staff.

b. Botanical Information and Exhibition Center

It is located at the left of entrance gate and is 2 storey building with information center and exhibition hall at the ground floor and restaurant at the upper floor. The main ground area exhibits rich flora and fauna of the country with various data about the biodiversity of Nepal. However, it is hardly seen by most of the people visiting the garden. Many are not aware about the existence of information center.



Figure 3. 10: Entry to Information center

Form, Design and Materials:

The building looks like residential house as it doesn't have any specific input of Architecture. The rectangular building is supported by 18 concrete pillars. The spaces in ground floor are allocated as exhibition Space, reception, store, general working area and restaurant entrance. The exhibit board at 7' height is in dynamic nature as it has organic shape that creates an interesting circulation space. The illumination level at the front façade is poor as the building shutters enclose the available windows hence requiring the need of artificial lights at the hall. The other side of the hall has ample light entry thus making space bright. The building has clear height 11'6". Marble is used as floor finish material.



Figure 3. 11: Interior of Exhibition hall

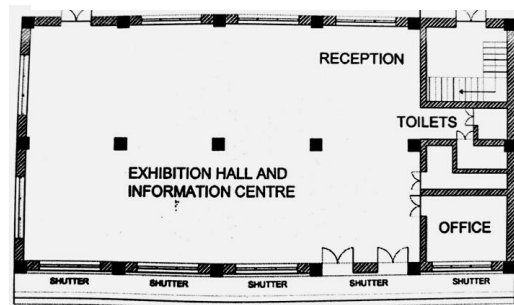

Figure 3. 12: Plan of Exhibition hall

c. Tropical House

It is a big house covering an area of 294 sq. m. with 12m height and was built in 1975 A.D. The hot and humid atmosphere inside the house stimulates the growth of low land plant species i.e., tropical plant species. It consists about 124 tropical plant species which has also been conserved to demonstrate the public for educational purpose. The objective of the house is to promote ex-situ conservation including study and research of tropical flora.



Figure 3. 13: Tropical House

The optimum desired temperature inside the greenhouse is 21-24 degree Celsius which is maintained via mechanical System i.e., it consists of exhaust fan for ventilation purpose

however in current condition it is not used. Artificial heating and cooling are not applied in this house as a pond is maintained inside for humidity.

Form, Design and Materials:

The greenhouse has central pyramidal unit reaching height 12m flanked by gabled greenhouses as its two ending sides attaining a total length of 24m. The tropical house is supported by truss system. With huge 12m vertical height., the greenhouse is supported by four huge 12" *6" four iron pillars on its inner core. The height is obtained as the iron truss transfers load to the pillars. It also consists of a base structural brick wall that helps to transfer the load to the ground. The covering material is glass.

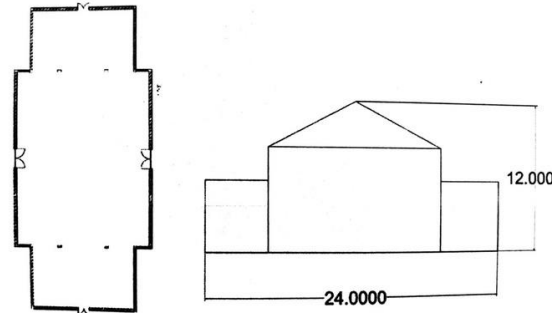

Figure 3.14: Plan and Elevation of Tropical house

d. Aquatic Garden

There are two aquatic pond that are scattered on the ends of the botanical garden and one at the starting point. The garden is provided with the island in the middle where the pillar is found which has a crown statue of king. Thus, the pond is also known as 'Sripez pond'. The pond shelters space for lotus some trees, shrubs, herbs, pteridophytes, Bryophytes and some algae. The whole aquatic garden is provided with a walkway on its all side. People not only use the pond for research purpose only, but it has also been used as a recreational space.



Figure 3.15: Coronation pond

Water Supply:

The water in the pond is supplied through natural steam water that flows in Godavari. The canals are constructed through which the water is supplied to the pond. The drainage pipe is fitted to the pond to flow water through the pond. But the strict pathways for outflow are not provided. Further the cleaning of the pond is not considered at all.



Figure 3.16: Aquatic garden near entrance

3.2.3 Inferences

- Analysis of built-up spaces and area allocation of different garden
- Understanding garden design, landscape and design elements
- Purpose of visit of people
- Conservation, education and management strategies.

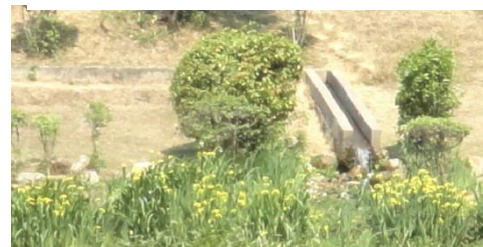

Figure 3.17: Water supplied through canal

3.3 Nepal Agriculture Research Council (Fisheries research Division)

Selection Criteria:

- Study Research Laboratory and research tanks.
- Examine Fish museum.
- Study fish food Production.

3.3.1 Introduction

Location: Godawari, Lalitpur

Building Type: Research Center

Aim: Fish Research and Breeding



Figure 3.18: Entry Gate



Figure 3.19: Administration Block

3.3.2 Site Plan

The building is in Godavari to fulfil the need of water for the culture of the fish. It has a secondary access road which is used to transport and supply equipment. This explains why the building was put in such a corner; it was done so that the building could have direct access to water.

3.3.3 Layout

On entering the gate towards the left is the guard house and on the right is large pond with naturally maintained ecosystem. Further Many circular research tanks are provided for multiple purpose i.e., Breeding as well as research purpose. **Fish Museum** has hundreds of museum specimen of Fishes found in rivers of Nepal. Research Laboratory has many labs such as **Genetics lab, Disease Lab, and water quality lab**. The research center holds the ponds as well as the raceway tanks for the still water and running water species. Being a large research center, it has allocated separate space for food preparation room, breeding etc. The raceways are placed at the top level and water thus flows from the respective tank are filtered and are used for the still ponds which are kept at the lower level. But currently raceway tanks are unused due to shortage of water. The food preparation room are kept at the midway between the raceway tank and the ponds. Food preparation mill has various machinery where raw materials are fed in to get the fish pellets. The ponds cover about 80% of the whole site while the administration covers 10% and the remaining breeding and food preparation covers about 10%.



Figure 3.20: Research Tanks



Figure 3.21: Research Laboratory

Special Features:

1. Fish Museum
2. Administration
3. Research Laboratory
4. Aquarium House
5. Food Production Mill
6. Breeding House

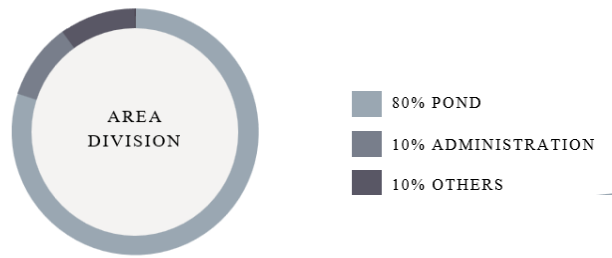

Figure 3. 22: Overall Area Division

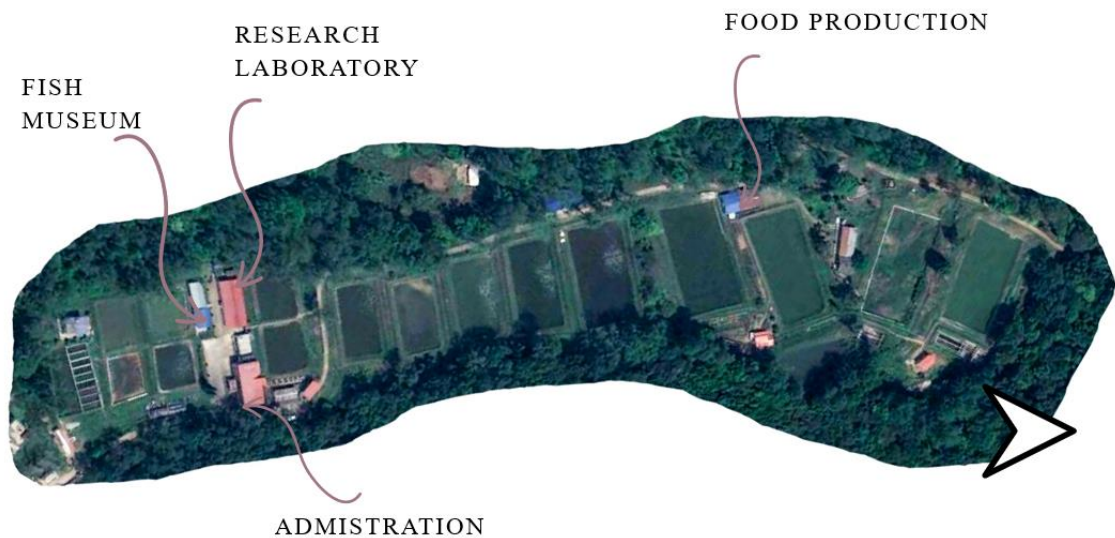

Figure 3. 23: Masterplan of Fisheries Research Division



Figure 3. 25: Food production mill



Figure 3. 24: Fish Museum

3.3.4 Water Inlet and Outlet

The water is flowed through natural steam to tanks. Different pipelines are connected at the end to flow water outward. It also helps to maintain the water volume inside tank. Net is provided at the end for the purpose of cleanliness. The tank is cleaned in 3-4 days.

3.3.4 Summary

- Laboratory is provided but features necessary for the lab are not managed.
- The building containing fish culture in large has not maintained safety standard.
- As the laboratory space and the ponds are scattered some spaces are not easy to reach by vehicle which can create problem for transportation of goods.
- Aquarium house is in abandoned condition.
- Unmanaged Fish Museum.

3.4 The Taraporewala Aquarium

3.4.1 Introduction

Date Opened: 1951

Location: Marine Lines, Mumbai

Number of Species: 100

Climate Zone: Warm and Humid

Taraporewala Aquarium in Mumbai is the oldest aquarium of India and among the most visited attractions of Mumbai. The project's goal was to produce an exhibit with educational value to raise awareness of marine life. However, thanks to its advantageous position on Marine Drive, this aquarium is now a popular tourist destination. Local people come to this place along with their family, and many kids also visit this aquarium during school excursions.



Figure 3. 26: Taraporewala Aquarium, source: goibibo.com

It has over 100 species of fish and other aquatic animals like sharks, seahorses and turtles. The collection consists of freshwater, marine and tropical fishes brought from around the world. Visitors enter the gallery through a glass tunnel around which fishes and water plants are on display.

Apart from the fish exhibition tunnel, Taraporewala Aquarium also has fishes in tanks. It has a small museum too, which has preserved corals, seashells, and fish skeletons.

3.4.2 History

Dr Rajendra Prasad, the first President of India, inaugurated Taraporewala Aquarium Mumbai in 1951. They added the 12-foot-long glass tunnel display recently, in 2013, when the aquarium was being renovated.

3.4.3 Design Basis

The basis of design included a strategic site selection and making the building an iconic one. Circulation was a key element included in the planning.

3.4.4. The location

- The splendid metropolis, which is Mumbai, Urbs Prima in India, had a humble origin.
- Three centuries ago, it was a fishing village.
- The aquarium is located along the 3 km long “Queen’s Necklace” The Marine Drive. The boulevard is lined with typical art deco buildings.
- The facility is at advantage considering accessibility owing to the proper road and rail connectivity.
- The Charni Road station is the closest local train station on the western line.

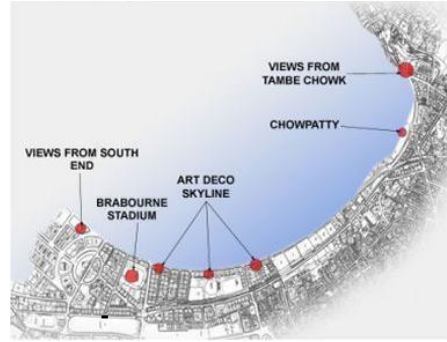

Figure 3. 27: Aquarium Location

3.4.5 The site and zoning

Site Area: 2250 m²

Aquarium: 480m²

- The site is flat and has a view to the promenaded Arabian Sea in front which compensates for the existence of no other major views around the site.
- There are public buildings like the auditoriums, convention centers (the NCPA) and service buildings like police stations, hospitals etc.
- The site has main aquarium zone, public zone and a restricted access zone for services.
- The aquarium zone houses the main building designed for display and labs.
- The public zone has a landscaped outdoor seating and a canteen complex.
- The service area has a building that accommodates all the filtering and water recirculation services and has a drinking water outlet too.



Figure 3. 28: Masterplan with Zoning

3.4.6 The Built From

- The building is an iconic structure on the Marine Lines and is very symbolic of its nature.
- It is two storied and built in framed RCC.
- The time of its construction is evident through its induced Parsee and art deco style.
- The mechanical systems building, and the canteen have been constructed in synch to the style of the main aquarium building form.

3.4.7 The Planning and Interiors

A. Ground Floor

- Entrance Hall
- Main Exhibition Hall
- Administration
- Aquarium
- Curator's Room
- Museum

The ground Floor accommodates the main exhibition hall with the equipment for circulatory and filtration. The entrance has a fountain connected to the fresh water circulatory system. To the right of the entrance, in the southwest corner of the building has the curators and conditioning room for observation. Marine species are displayed in 18 tanks while fresh water in 9 tanks. The tank is of R.C.C footage with glass about 1 and a quarter inch. The tank is of different capacity ranges from 1000 gallons to 1500.

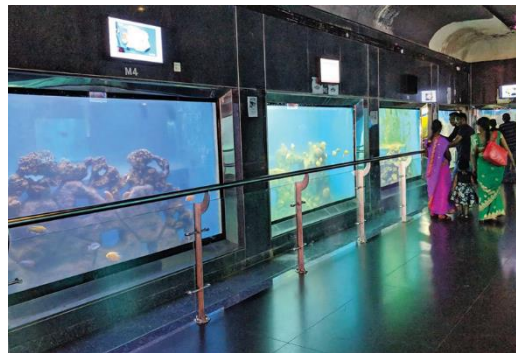

Figure 3. 29: Display Gallery, source: archdaily.com



Figure 3. 30: Aquarium Tunnel, source: archdaily.com

B. First Floor

- Marine biological laboratory in northwest wing
- Fresh water laboratory in southwest wing
- Tanks are provided for observation in controlled condition.
- Office of the director of fisheries.
- Space for Staff.

C. Second Floor

- It holds Library.

3.4.8 Services

a. Air Supply

- Elaborate arrangements have been made to ensure a constant stream of air in all tanks.
- The silvery jet of bubbles, spiraling to the surface of the water from the bed of the tank is compressed air released in each tank.

- Proper aeration is necessary for the wellbeing of the exhibits.

b. Illumination

- Affected by concealed bulb.
- Skylights are tinted blue to prevent growth of algae.
- Arrangements are done to regulate the volume of lights.



Figure 3. 31: Lighting in Display area, source: archdaily.com

c. Purification Plant

- Both systems have underground setting tank and filtering units.
- Filtering media of pebbles of varying grades arranged in layers.

d. Circulatory System

- Closed Type

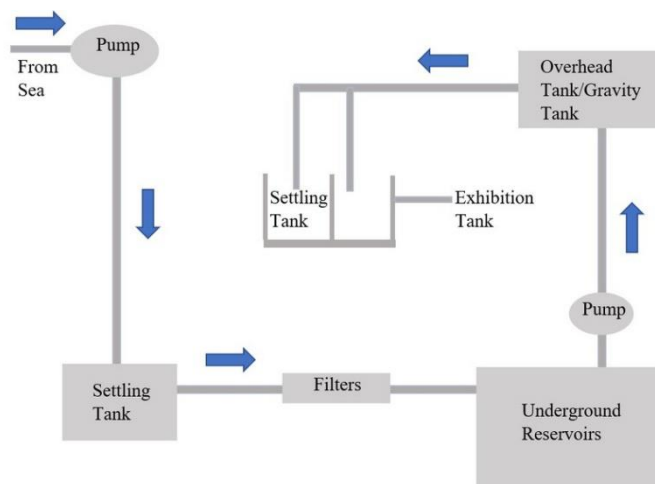

Figure 3. 32: Water Circulation Diagram

3.4.9 Critical Analysis

- The façade of the building does not suit the inside context.
- Monotonous interior arrangements.
- Enclosure for marine mammals like turtles, skates are too small.
- The circulation is uni-directional, which is good for circulation
- The area close to the tank about 1m is cordoned off, which is good for security reasons.

3.4.10 Inferences

- Train like arrangement should be avoided
- Inclusion of a museum should be considered as a valuable learning experience.
- Inclusion of Public amenities such as libraries and sea food selling can be helpful for sustaining the aquarium.

- Service corridor should be raised and away from visitor's access.

3.5 Monterey Bay Aquarium

Selection Criteria

This case study was chosen due to following reasons:

- Study the exhibition themes
- Examine a large water system
- Examine the basic program and areas of the public aquarium.
- Examine the research facility

3.5.1 Introduction

Location: 886 Cannery Row, Monterey, California

Function: Aquarium

Site area: 26.25 ropani

Construction: 1984 A.D.



Figure 3. 33: Monterey Bay Aquarium, source: archdaily.com

Monterey Bay Aquarium is a nonprofit public aquarium in Monterey, California. Known for its regional focus on the marine habitats of Monterey Bay, it was the first to exhibit a living kelp forest when it opened in October 1984. Its biologists have pioneered the animal husbandry of jellyfish and it was the first to successfully care for and display a great white shark. The organization's research and conservation efforts also focus on sea otters, various birds, and tunas.

Monterey Bay Aquarium was built at the site of a defunct sardine cannery and has been recognized for its architectural achievements by the American Institute of Architects. Along with its architecture, the aquarium has won numerous awards for its exhibition of marine life, ocean conservation efforts, and educational programs.

Monterey Bay Aquarium receives around two million visitors each year. It led to the revitalization of Cannery Row, and produces hundreds of millions of dollars for the economy of Monterey County.

3.5.2 History

In the early 1960s, scientists at Stanford University's Hopkins Marine Station grew wary of the growing industry on Cannery Row. The station succeeded in convincing the university of their concerns in 1967, and Stanford University purchased the property on Cannery Row that housed the Hovden Cannery, a sardine cannery on the border of Monterey and Pacific Grove. In the late-1970s, four marine biologists thought of building an aquarium on the Hovden Cannery site.

Those involved intended to reconstruct Hovden Cannery rather than destroy it so Concrete sections of the building were able to be kept, but other areas were repurposed; the cannery's old warehouse was converted into administrative offices, and a seawater system for the aquatic exhibits replaced the cannery's pump house that brought fish to the warehouse from floating storage tanks in the bay. As the building would reside partially over water, unique challenges occurred throughout construction. Nearly half of the aquarium would be located over the bay in depths of up to 120 ft (37 m), requiring foundational elements to be installed during low tide, which often occurred at night.

The ironic transition from a plant that processed fish to an aquarium which would display them didn't prevent the facility from appearing like a cannery, according to multiple journalists. When Monterey Bay Aquarium opened on October 20, 1984, it was the largest public aquarium in the United States. On opening day, 11,000 visited it and around 30,000 people attended the day's festivities. Within five years, it was reported in the *Los Angeles Times* that it was among California's most popular visitor attractions.

By 1994, it was the most attended aquarium in the United States.

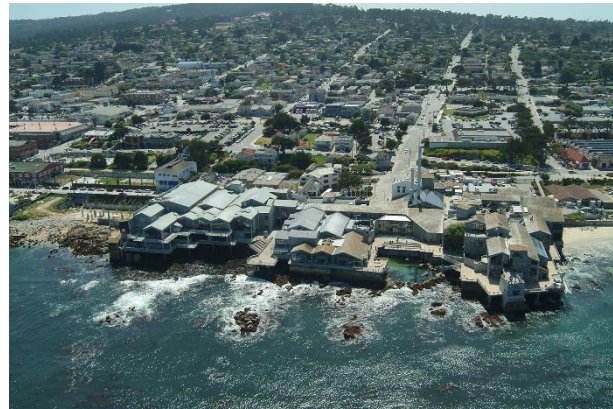

Figure 3. 34: Ariel view of Monterey Bay Aquarium, source: archdaily.com

3.5.3 Site

The aquarium stands on the site of what was historic cannery the Hovden Cannery, and on adjoining cannery and warehouse properties. Built in 1916, the cannery operated until 1972, and was the last of the canneries to close. Stanford university purchased the property to protect the next to its Hopkins Marine station. then sold it the aquarium foundation in 1978. Initial plans to house the aquarium in the actual cannery structure proved impractical, though elements of the original are preserved."(*Monterey Bay Aquarium Overview, 2010*)

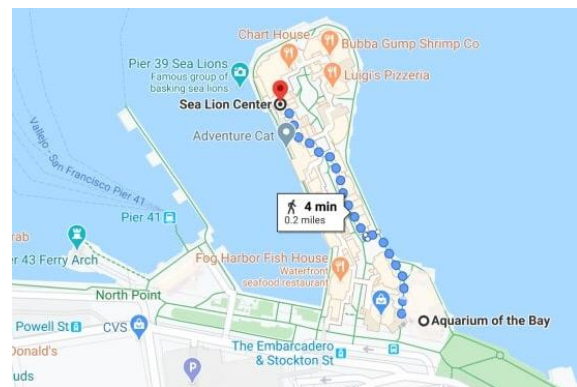

Figure 3. 35: Site Location

The location of the Aquarium is an ideal place to have open ocean viewing. Showing people what is happening in the area they live in or are visiting helps them understand what is happening in the real ocean not just people-controlled tanks.

Large walls of glass give a view in to the open ocean tank allowing visitors to see the tank from under the water and the terraces allow the view from above.

3.5.4 Architectural Form

The design of the aquarium and its Outer Bay wing intentionally preserves the historic flavor of Cannery ROW and the old cannery that inspired the aquarium. Several important elements of the aging Hovden complex were restored for use or display in the aquarium, including the old boilers, pump house and warehouse. Other new construction too is inspired by the same form and pay respect to the historic importance of the site.

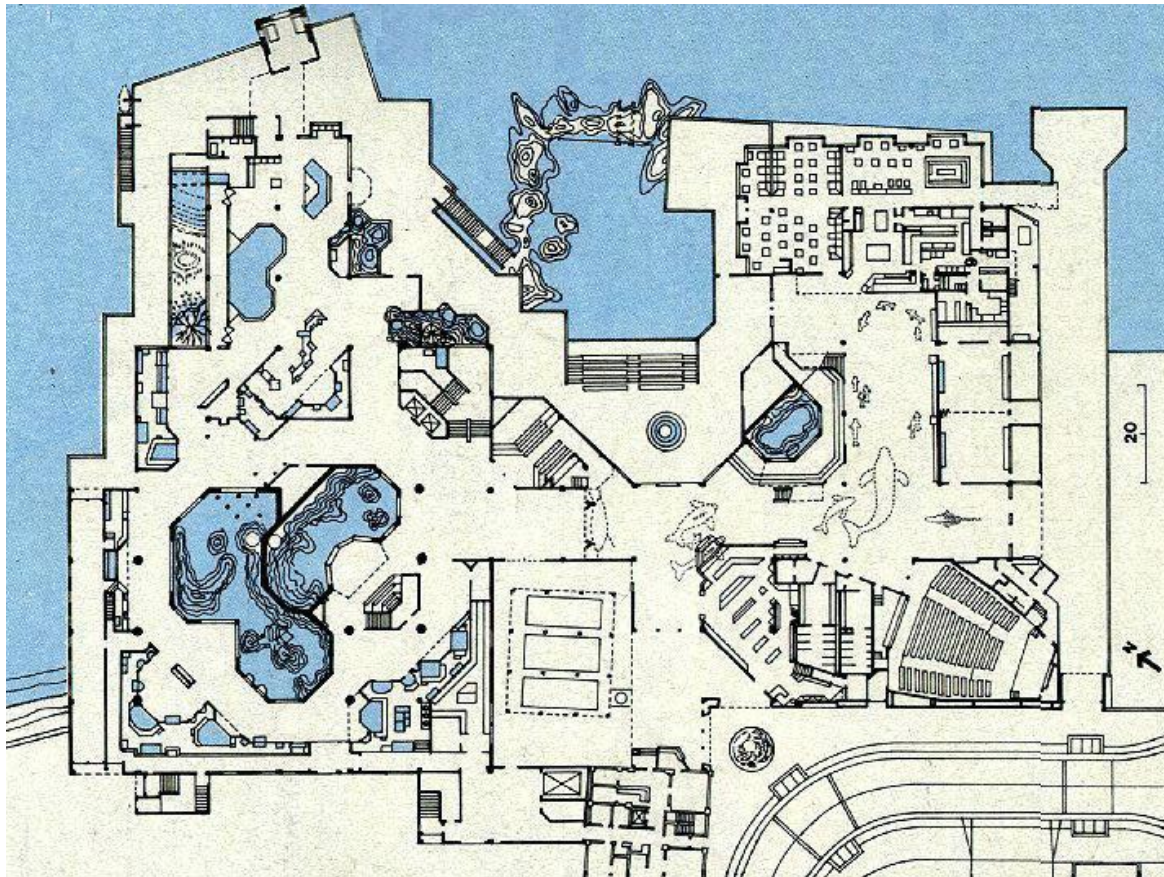

Figure 3.36: Masterplan of Monterey Bay Aquarium

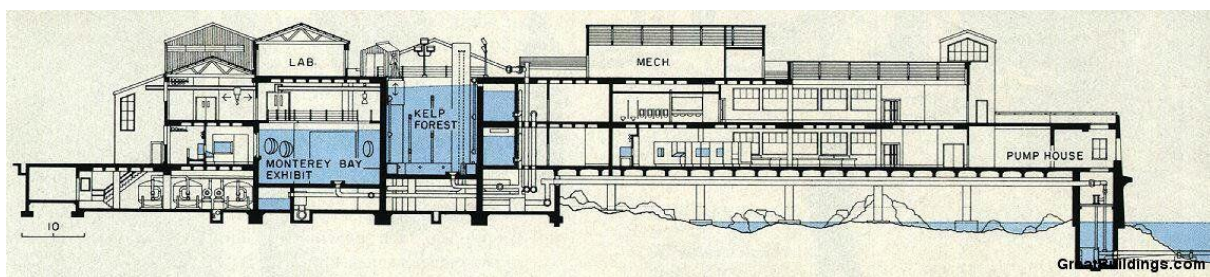

Figure 3.37: Section through Kelp forest

3.5.5 Galleries and Major Exhibits

There are nearly 200 galleries and exhibits devoted to the diverse habitats of Monterey Bay. The four largest exhibits are the Outer Bay (1 million gallons); the Kelp Forest (335,000 gallons); Monterey Bay Habitats (326,000 gallons); and Sea Otters along the Rocky Coast (55,000 gallons).

Some other galleries include:

Marine Mammal gallery, Splash zones, Great tide pool, Mission to the deep, Deep reef, Sandy Seafloor, Shale Reef etc.

a. Outer Bay Gallery

The open sea is a vast blue world seemingly without boundaries, and the Outer Bay exhibit (encompassing open ocean waters of the temperate Eastern Pacific) gives visitors a sense of its enormity. Visitors look through one of the largest windows on Earth — 54 feet long, 15 feet tall and 13 inches thick, weighing 78,000 pounds— into a 90-footlong, 35-foot-deep exhibit, one of the tallest aquarium exhibits in the world.



Figure 3. 38: Baby otter, source: archdaily.com



Figure 3. 39: Outer Bay, source: archdaily.com

At 28 feet (8.5 m) tall and 65 feet (20 m) long, the Kelp Forest exhibit is the focal point of Monterey Bay Aquarium's Ocean's Edge wing. Nearly three stories high, the exhibit is regarded as the first successful attempt to maintain a living kelp forest in an artificial setting. The exhibit's success at sustaining giant kelp and its realistic appearance is attributed to the availability of direct sunlight, the use of natural seawater from Monterey Bay, the 5-foot (1.5 m) surge machine and water jets hidden in the exhibit's rockwork maintain the constant water motion that kelp requires to absorb nutrients. Kelp forests are important ecosystems along California's coast—compared to tropical rainforests in their biodiversity—and, alongside giant kelp, the exhibit contains species of fish indigenous to Monterey Bay, including rockfishes and leopard sharks. Diver's hand-feed the fishes daily in demonstrations that include narration by a volunteer guide and two-way communication between diver and the audience.



Figure 3. 40: The Kelp Forest

b. Sea Otters along the Rocky Coast

The 55,000-gallon sea otter exhibit gives visitors a close-up look at these playful and curious mammals above and below the surface, together with marine plants, fishes, and invertebrates. The result is an exhibit that looks much like the otters' wild environment.

c. Monterey Bay Habitats

Sharks, salmon, halibut, striped bass and many other fishes roam this 90' long, hourglass-shaped exhibit. Four habitats in the bay have been re-created here: the deep reefs, the sandy seafloor, the shale reefs, and the wharf. Bubble-shaped viewing windows offer an intriguing perspective on the deep reefs, while large acrylic windows provide a series of broad vistas into the exhibit. The hourglass shape gives sharks the long straight glide path they need to keep water moving efficiently over their gills. Actual wharf pilings from Monterey harbor anchor one end of the exhibit, while common murrens — a species of seabird — paddle on the surface or dive and swim underwater. Visitors can view the exhibit on two levels: underwater on the aquarium's main floor; or from the surface at an overlook in "Splash Zone" near the penguins that offers a peek behind the scenes.

3.5.6 Other Facilities

"Other facilities include a 1,200-square-foot water-quality laboratory; the Tuna Research and Conservation Center, a collaborative project with Stanford University located next door to the aquarium at Hopkins Marine Station; the Animal Research and Care Center, a research and holding facility for future exhibit animals; a 183-seat ocean-view restaurant with self-serve cafeteria and full-service restaurant and bar; 273-seat auditorium with state-of-the art sound and video systems; two Discovery Lab classrooms equipped with seawater systems, video conferencing equipment and Internet access; and gift & bookstores." (*Monterey Bay Aquarium Overview, 2010*)

3.5.7 Seawater System

In the Ocean's Edge galleries, fresh seawater is pumped continuously and directly from Monterey Bay to maintain the great diversity of plant and animal life in the exhibits. By day, filtration leaves the water clear for public viewing. At night, unfiltered seawater flows through the exhibits. The raw seawater not only sustains filter-feeding animals, but it also carries in spores and larvae of plant and animal life that settle and grow in the exhibits — making the exhibits a "living extension" of the bay. Water enters through two 16-inch diameter, 980-foot-long intake lines located 55 feet deep in the bay. Pumps draw up to 2,050 gallons of seawater per minute into the aquarium seawater distribution system, 24 hours a day, seven days a week—more than a billion gallons of water a Year. Four operating modes permit varying levels of filtration, from raw seawater to pressure-sand-filtered, de-embolized seawater. Most aquariums are located on polluted bodies of water or inland of the coast, making "open" system designs like this impossible.

The Outer Bay galleries operate on a "semi-closed" system. Water from the main intake lines is piped to the new wing where it is heated to 68 degrees Fahrenheit and circulated through the exhibits. Replacement water is added at a rate of 100 gallons per minute. Biological filters and treatment remove wastes in the water, A heat recovery system recaptures energy from the water before any is discharged to the bay. Separate life support systems supply cooler.

3.5.8 Inferences

- Respect to the site is essential in any design.
- Universal design is a very important part of any public project.
- Merits and demerits of Open water circulation system

- Locally available resources should be used in an optimum amount, without depleting the resources.
- Use of open-air exhibits, blending with the environment can be very successful and powerful form of exhibit.

3.6 The Blue Planet, Denmark

Selection Criteria

This case study was chosen due to following reasons:

- Unique Architectural Form
- Thematic Exhibitions
- Appropriate size for proposed site
- Vibrant interiors
- Challenging structural system

3.5.1 Introduction

Location: Kastrup, Denmark

Function: Aquarium

Site area: 12000 sq. m (23.59 ropani)

Gross floor area: 9,700 sq. m. (19 ropani)

Construction: 2013 A.D.



Figure 3. 41: The Blue Planet, source: archdaily.com

The Blue Planet is Europe's largest and most significant aquarium with an outstanding location on the shores of Oresund, only eight kilometers from the Copenhagen City Hall Square. Visitors can easily access the aquarium as it is well connected to the city by the means of motorways, metro and international airways.

3.5.2 History

Denmark's Aquarium was founded by civil engineer and contractor Knud Hojgaard. It opened for the public in 1939 just four months before the breakout of World War II and seven months before the occupation of Denmark. The consequence was closed borders and considerable problems in getting hold of exotic animals to the aquarium. However, through an impressive effort with Danish and home reared fish the aquarium was kept open and active. After the war, the aquarium was in a bad shape, and Knud Hojgaard initiated extensive renovations. During the next decades the building went through several modernizations and enlargements.

3.5.3 Concept

The 97,000 square foot aluminum-clad **whirlpool** which constitutes the architectural trademark of the building, along with being an iconic shape reminiscent of the "form of the water".

Inspired by the shape of water in endless motion, Denmark’s new National Aquarium, **The Blue Planet** is shaped as a great whirlpool, and the building itself tells the story of what awaits inside. The whirlpool concept originates in a narrative about water, and as an image, is at once both abstract and figurative. It stirs attention with its distinctive vortex blades, but at the same time, as a building, changes dramatically depending on viewing angle, distance, and daylight conditions. From the air, almost entirely white, its contours are reminiscent of a starfish. From the front, the building’s organic lines are evocative of silvery-grey waves or a vast sea creature, and on closer inspection, the facade patterning is reminiscent of fish scales. This is a building that invites interpretation.

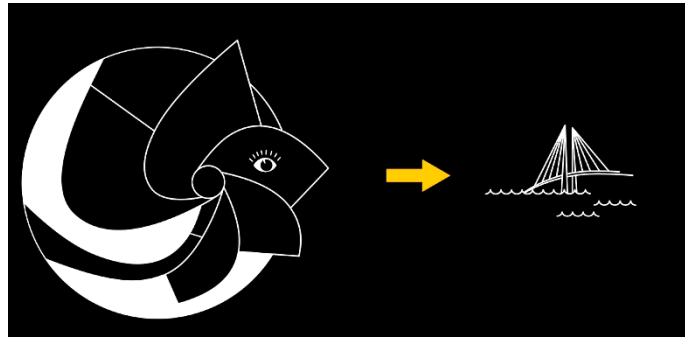

Figure 3.42: Concept Development, source: archdaily.com

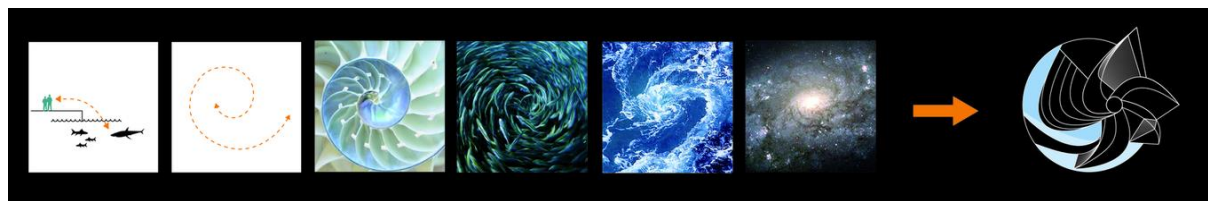

Figure 3.43: Whirlpool Concept, source: archdaily.com

The whirlpool concept was chosen as ideal not only for its visual associations, but also because it resolved a practical challenge in the design brief: it ensures that one or more of the whirlpool arms, with relative ease and without disrupting the building’s integrity nor the operation of the aquarium, can be extended with more than 30 % to create more exhibition space.

3.5.4 Planning

Each of the five arms which form the spiral houses a specific functional area. While the first arm accommodates a long arrival ramp and the entrance hall, and the second houses an auditorium, an educational facility, and a cafeteria; the remaining three contain the permanent exhibition and accommodate, respectively, the sections dedicated to seas & oceans, to rivers & lakes, and to Danish cold waters. The five arms curl around a central foyer from which the public can access the exhibitions independently from one another.

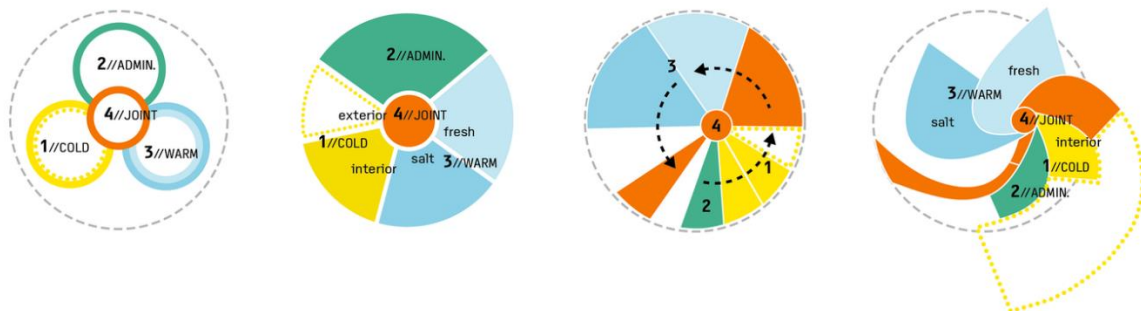

Figure 3.44: Planning approach, source: archdaily.com

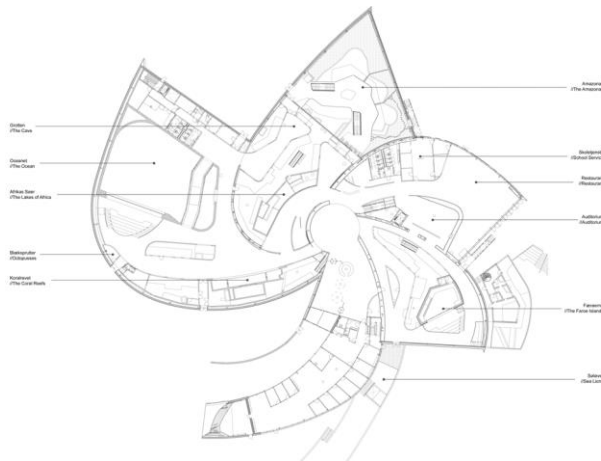

Figure 3. 46: Masterplan of The blue Planet



Figure 3. 45: Sectional 3d view, source: archdaily.com

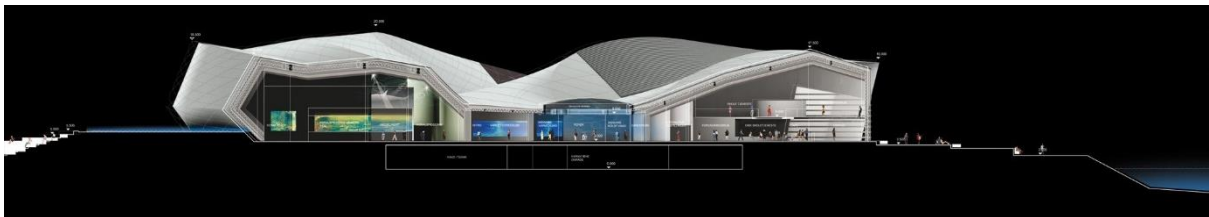

Figure 3. 47: Aquarium Sections, source: archdaily.com

The arrival and Interior:

Visitors reach the entrance by following the first and longest of the whirlpool's arms, already starting in the landscape. With a smooth transition, the landscape surpasses for the building, while the outdoor ponds mark the unique experience that awaits the aquarium visitors as they enter: the whirlpool has pulled them into another world – a world beneath the surface of the sea.

A circular foyer is the center of motion around the aquarium, and it is here visitors choose which river, lake, or ocean to explore. By enabling multiple routes, the risk of queues in front

of individual aquariums is reduced. The interiors range from grand to intimate settings, allowing the architecture and the exhibits to jointly convey an array of diverse environments and moods.

The curved ceilings of the aquarium are reminiscent of the baleens of a large whale. The exhibition is a total concept offering all visitors a sensuous and captivating experience of life in and under the water. A mixture of light, sound, advanced AV-technology, projections, film, interactivity, graphics, illustrations and signs aimed at all age levels ensures that every visitor, regardless of background or interests, has the best experience possible. As the only aquarium in Denmark, The Blue Planet focuses on all aquatic life – from cold and warm waters, fresh and salt. In total, The Blue Planet contains app. 7 million liters of water and 53 aquariums and displays. The restaurant's decor is based on the colors and expressions that characterize Nordic nature. The restaurant faces south-east, and thus offers a panoramic view of the sea. The outdoors facilities include a terrace with seating, a pond with carps and a tank with sea lions. The sea lions can also be looked at from the inside of the aquarium.

Galleries:

In the first year of existence, the aquarium received approximately 1.3 million visitors – twice as many as expected. The Blue Planet contains about 7,000,000 liters (1,500,000 imp gal; 1,800,000 US gal) of water divided into 53 exhibits. There are five main sections:

The Rainforest:

The rainforest is home to dwarf and Philippine crocodiles, arowanas, pacus, freshwater stingrays, large catfish, boa constrictors, violet turaco and more. This section also has an aquarium with a big school—about 3,000—of piranhas. Near the rainforest is the smaller grotto section, with aquaria for cave tetra, various electric fish (electric eel and elephant fish) and other fish found in dark freshwater habitats.

The African Great Lakes:

Exhibits for Lake Malawi, Lake Tanganyika and Lake Victoria. Primarily aimed at cichlids, but also home to other fish such as Nile perch and the section above the aquaria are home to village weaver birds, and other small animals.

Evolution and adaption:

Aimed to display the evolution and adaptations of fishes. Gallery has mangrove aquarium.



Figure 3. 49: Display Gallery, source: archdaily.com



Figure 3. 48: Display Gallery, source: archdaily.com



Figure 3. 50: The Amazonia, source: archdaily.com

Cold Water:

Primarily home to native Danish species from fresh- and saltwater. Among others, it includes a touch pool, Non-native species in or near the Cold Water section are giant Pacific octopus, sea anemones and more.

The Warm Ocean:

This section contains the largest aquarium in Blue Planet, the 4,000,000-litre Ocean tank. It is home to sharks, stingrays, eagle rays, guitarfish, moray eels, and more that can be seen through the 16 by 8 m (52 by 26 ft) main window, which is 45 cm (18 in) thick. There is also a 16 m (52 ft) long shark tunnel. Opposite the Ocean Tank is the 16 m (52 ft) long coral reef with living corals and reef fish.

Other Facilities:

Includes laboratories, auditorium, sea facing cafeteria, administration, gift shops, outdoor exhibition space and parking for 200 vehicles. Landscape also has viewing deck that looks over ocean. (*THE BLUE PLANET, 2013*)

Analysis of space:

Entry foyer: 220sq. m

Gift shop: 175 sq. m with storage

Administration: 430 sq. m

Exhibition Galleries:

The rainforest: 720 sq.m

The African Great lakes: 180 sq. m

Evolution and adaption: 175 sq. m

Cold Water: 235 sq. m

The Warm Ocean: 511 sq. m

Coral reef: 350 sq. m

Multipurpose hall: 110 sq. m

Cafeteria: 350 sq. m

Special Exhibition: 110 sq. m

3.5.6 Structural Considerations:

- The site for the building lies beyond the original coastline so the building rests on special pile structure.
- The services and sewerage line remains suspended in concrete structure. The service line built 1.6km into ocean to extract suitable water for aquarium.
- Load bearing steel structure framework
- Double curved steel surfaces to generate the curvilinear whirlpool form

- Construction with the help of Building Information Modelling (BIM)
- Total 54 steel frames, no two frames are identical.

3.5.7 Inferences:

- Site Chosen must be easily accessible to public
- The building form must reflect the concept behind it
- Central lobby must be used to welcome visitors, to let them adjust to the interiors and a distribution note to various other spaces.
- Themed exhibitions should have a circulation pattern defined so no loop is missed.
- It is architecturally and aesthetically pleasing to have a form-plan relation in design.

4.0 Site Analysis

4.1 Selection of the site

About Site

Location: Panchase Marga, Pokhara

Climate: Warm and Temperate

Area: The site covers 21500 sq.m. (approx. 42 ropani)

Access to site: Access Road from N

Topography: Slightly sloppy towards lake



Figure 4. 1: Site Location

The site, Pokhara is one of the most popular tourist destinations and is without doubt one of the best natural as well as one of the most beautiful paces of the world. Fewa lake and Waterspouts are the main tourist attraction of Pokhara city.

In order to fulfil the objective of the project proper selection of site is a must. By finding out the potential and the surrounding context of the site, the aquarium was proposed. There are certain criteria which justifies why the selected thesis topic was appropriate for the site. The site for this project should be located not very far from the main city core but yet have a quiet and beautiful surrounding environment that would offer a pleasant working environment and with the availability of water source. With considering above statements, the site for my thesis project Freshwater Aquarium and Research Center, I have chosen area adjacent to the Fewa Lake, Pokhara. The people visiting the aquatic research Centre will directly or indirectly benefit of natural lake, on the other hand, the implementation of high-tech aquariums inside the center will further acts as the conservation of species.

The northern shore of the lake has developed into a tourist district, commonly called Lakeside. The serenity of Fewa Lake and the magnificence of the fish-tailed summit of Machhapuchhre rising behind along with the world-famous twinkling snow-capped Annapurna, Dhaulagiri create an ambience of peace and magic.

Where else can be the best site than this for a building that shows the relation between the Himalayas, the water bodies, the residents of those water bodies and the people of Nepal?

4.2 SWOT Analysis

Strength

- Renowned Location
- Easy Access
- Sub-Urban Settlement, untouched with city crowd
- Good lake view
- Green Hills around
- Free from Urban Congestion
- Access to various recreational facilities.

Weakness

- No municipal Sewerage System
- No proper land management, infrastructural facilities
- Relatively weak soil

Opportunities

- Iconic building, unique identity all over the country
- No significant aquatic development in site surroundings
- One of the most popular waterfronts as public space
- Internal as well as external tourist as its target group
- Wide range of activities within the premises.

Threats

- Political imbalance and low tourist arrival
- Vandals and anti- social activities
- Change in government policies
- Market inflation

4.3 Site Analysis Data

Site:

The site is located at Lakeside, Pokhara (28° ISN, 83° 55'E). The site covers 21500 sq. m. (approx. 42 ropani)



Figure 4. 7: Eastern View from Site



Figure 4. 6: Western View from the site



Figure 4. 5: N-E side view



Figure 4. 4: Northern View from site



Figure 4. 3: Southern View



Figure 4. 2: Fewa Lake seen from site

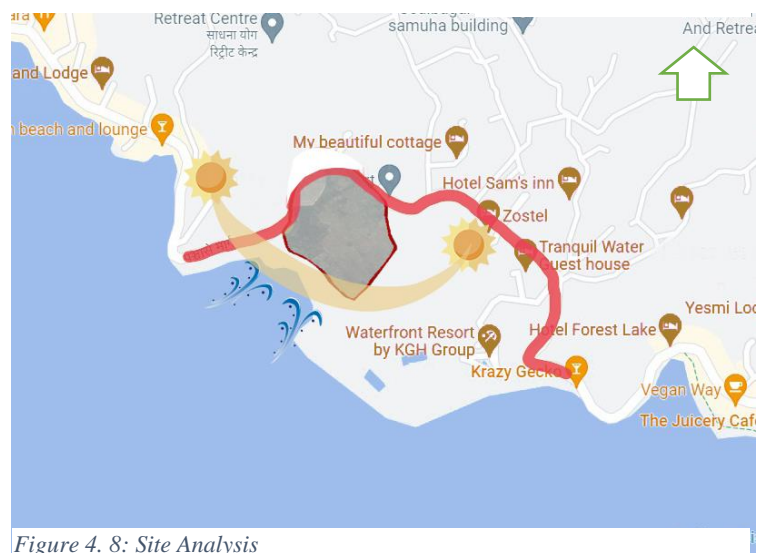

Figure 4. 8: Site Analysis

Topography:

The site is 742 meters above sea level and is located right on the bank of Fewa lake. Slightly sloppy towards lake. The site is arguably the best to watch the Vastness of serene water body of Pokhara.

Climate:

With reference to the weather station at Lakeside, Pokhara following climatic references has been drawn. Maximum: 30°C, Minimum: 7°C

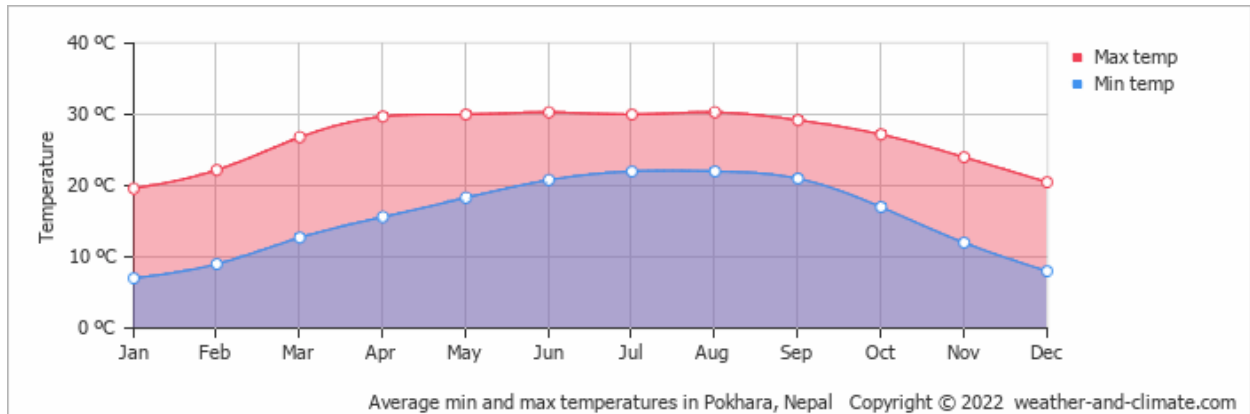

Figure 4. 9: Climatic data, source: weather-and-climate.com

Relative Humidity:

Average relative humidity is 78%.

Precipitation:

Max: 900mm/month

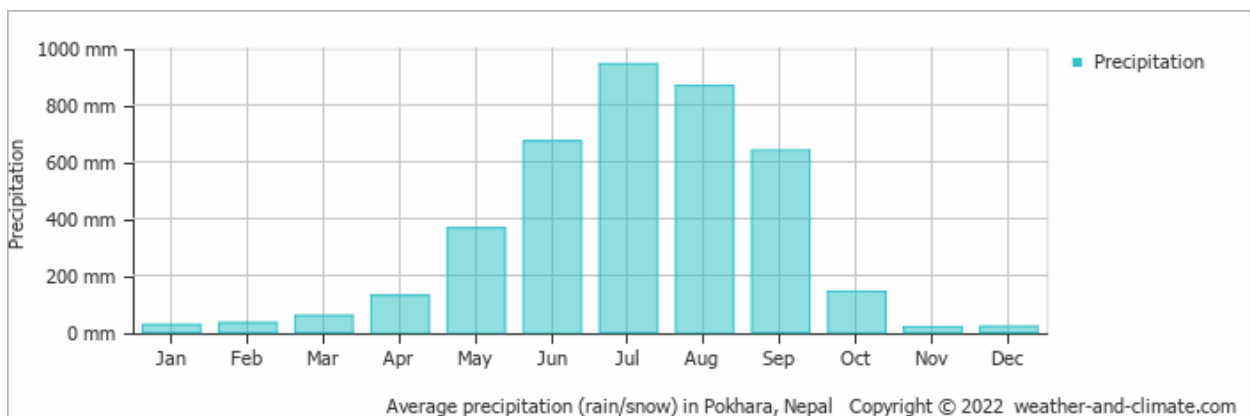

Figure 4. 10: Precipitation data, source: weather-and-climate.com

Wind:

The climate deviates from the comfort range due to summer sun and chilling winter cold, So keeping the summer sun away and letting winter sun in is an important aspect of building design. Careful detailing of building envelope as well as need for protection against rain becomes indispensable too.

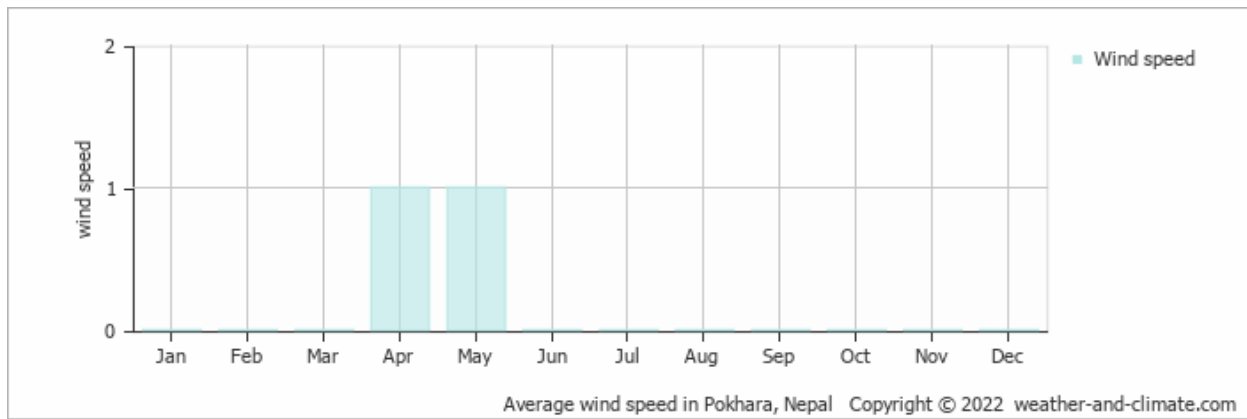

Figure 4. 11: Wind data, source: weather-and-climate.com

The surrounding area:

South: Fewa lake, World Peace Pagoda, Pumdikot

West: Pame Village

North: Sarankot Hill

East: Heaven View Pokhara

Geology and Soil:

The site is slightly sloppy towards lake and the soil present in the side is acidic, moderately fine textured and non-stony clay.

Hydrology:

Since the site is located right on the bank of Fewa lake. The quality of lake water goes on degrading everyday by unmanaged solid waste disposal from different hotels and resorts standing on the northern and eastern shore of the lake.

Vegetation/Ecology:

The land use pattern around the lake is varied, with a river channel zone in the eastern side of the lake shore, silt trap zone on the western side, agricultural land with dense urban areas on the northern side and forested areas, with sparse settlement on the southern side. The watershed of the lake consists of forested areas (44%), agricultural land (39%), urban and watershed area (5%), pasture and barren land (5%), lake area (4%) and shrub land (3%).

Services:

Municipal water supply from pipeline. Fewa Powerhouse is located about 1.5 km (0.93 mi) from the southern part of the Fewa lake which generates electricity. Telephone, sewer lines are present in the site or could be easily connected to them. Suitable and environmental friendly design is necessary to connect to the main sewer pipes and make sure that the lake doesn't get polluted.

Socio-economic Pattern:

- Society around the site is emerging as urban.
- Settlements- Gurungs and Local Boat owners
- Main occupation is tourism, agriculture, boating and fishing.
- The ethnic community called "Pode or Jalari" is depended on fishing in the lake.

Traffic and access routes:

The site is just about 4km away from Pokhara Airport and one can easily reached to the hotel in about 15 minutes in taxi.

Important Nearby Venues:

Pokhara City is itself a venue for external and internal tourists. If we talk about places to visit in pokhara then we shouldn't omit to visit following places

- World Peace Pagoda
- Pumdikot
- Phewa Lake and Tal Barahi Temple
- International Mountain Museum,
- British Gurkha Museum
- Bat cave, Gupteshwor cave, Mahendra cave, Davis falls
- Sarangkot, Kaskikot, Begnas Lake etc.

Bye Laws:

FAR: 2.5

Ground coverage: Maximum 40%

Setbacks: 20m from lake boundary

4.4 Inference from Site:

- North- Main entry to be planned on the north as main road lies in this direction since the site is directly linked with 24 ft road.
- South- The Bird view deck and public waterfront plaza can be oriented towards south provides a mesmerizing view of lake as well as in the mornings, as the sun's rays catch the Peace Pagoda above the southern lake shore, one will see fishermen paddling their boats close to the lake's edge pulling in their nets & it would be a wonderful experience.
- East — East boundary of site has open ground so recreational spaces are allocated here.
- West- West boundary of site is not linked with the boundary of the lake so Back of The House facility can be provided here along with loading and receiving specimens and other service facilities.

5.0 Program Formulation

The project consists of the following spaces

1. Visitor's per day: 500 visitors per day(Proposed)
2. Reception Zone

Table 5. 1: Program formulation: Reception zone

S.N.	Component	Nos.	Capacity	Area/Person (m ²)	Area (m ²)	Remarks
Reception Zone						
	Guard House				20	
	Reception	2		8	16	2*8
	Ticket counter	2		2	4	2*2
	Security Checking	2		2	4	2*2
	Toilets	15	1 unit per 20 visitors	5	75	15*5
	Central lobby		148	Standing: 1 Sitting: 1.25	160	100*1+48*1.25
	Total				279	

3. Administration

Table 5. 2: Program formulation: Administration

S.N.	Component	Nos.	Capacity	Area/Person	Area (m ²)	Remarks
Administration						
	Manager's Room (PA+ Meeting room+ Waiting+ Toilet)	1		13 Waiting: 1.25 Toilet: 5	61	
	Assistant Manager room	1		13 Waiting: 1.25 Toilet: 5	61	
	Curator's room (PA+ Waiting+ Toilet)	1		13 Waiting: 1.25 Toilet: 5	45	
	General office (Specialists)	5			46.5	5*9.3
	Publication room	4			32	4*8
	Staff Lounge/ Breakout	1	20		60	20*3

	Pantry & Store				20	
	Toilet	4			20	4*5
	Total				345.5	

4. Display gallery

Table 5. 3: Program formulation: Display Gallery

S.N.	Component	Nos.	Capacity	Area/Person	Area (m ²)	Remarks
	Display Gallery					
	Gift shops			15	105	
	Shipping and receiving	2		185	370	
	Permanent exhibition tanks			2-D display: 3.5 3-D display: 6-10	2500	
	Specialized viewing area			2-D display: 3.5 3-D display: 6-10	250	
	Special exhibition			2-D display: 3.5 3-D display: 6-10	250	
	Storage area	4		140	560	
	Refrigeration			500	500	
	Docks	4		87.5	350	
	Total				4885	

Table 5. 4: Program formulation: Life support & Maintainance

S.N.	Component	Nos.	Capacity	Area/Person	Area (m ²)	Remarks
	Life Support & Maintainance					
	Mechanical Area			1:1 with tank display area	2400	
	Service Area				200	
	Work Area				170	
	Quarantine Area				600	1:3 (Display Tank)
	Total				3370	

Table 5. 5: Program formulation: Services area

S.N.	Component	Nos.	Capacity	Area/Person	Area (m ²)	Remarks
	Services Area					
	AC plant room				60	
	Electric sub station				50	
	Pump room/ Filtration				50	
	Water Storage				30	
	Miscellaneous				80	
	Total				270	

Table 5. 6: Program formulation: Storage

S.N.	Component	Nos.	Capacity	Area/Person	Area (m ²)	Remarks
	Storage					
	Collection Office				75	
	Food prep. room				155	
	Freezer room				30	
	Wet Storage				60	
	Toilet			5	20	5*4
	Total				340	

5. Cafeteria

Table 5. 7: Program formulation: Restaurant

S.N.	Component	Nos.	Capacity	Area/Person	Area (m ²)	Remarks
	Cafeteria					
	Seating		288	0.78	225	288*0.78
	Kitchen			40% of seating area	90	
	Rest room			1 unit/20 seats (5 m ² per unit)	25	
	Total				340	

6. Conservation & Education Center

Table 5. 8: Program formulation: Education Center

S.N.	Component	Nos.	Capacity	Area/Person	Area (m ²)	Remarks
Education Center						
	Seminar Hall	1	50	1.25	75	
	Activity room/ Workshops			3	75	
	Museum			3-5	150	
	Classroom	2	20	1.3	52	
	Rest rooms			1 unit/20 seats (5 m ² per unit)	15	
	Total				367	

Table 5. 9: Program formulation: Library

S.N.	Component	Nos.	Capacity	Area/Person	Area (m ²)	Remarks
Library						
	Books collection					3 books per visitor
	Spaces for book collection			0.006	10	
	Space for readers		30	2.5	70	
	Computer room		5	3.5	17.5	
	Staff working Space		10	2.5	25	
	Miscellaneous				50	
	Total				172.5	

Multipurpose hall

Table 5. 10: Program formulation: Multipurpose hall

S.N.	Component	Nos.	Capacity	Area/Person	Area (m ²)	Remarks
Multipurpose hall						
	Foyer		150	0.6-0.8	90	
	Hall		150	1.2	180	
	Stage		150	25% of hall area	45	
	Technical room			10% of hall area	18	
	Changing room		8	4	32	
	Rehearsal room		16	1.4	22.4	
	Rest room		8	1 unit/20 seats (5 m ² per unit)	37.5	
	Store			10% of Hall	18	
	Total				442.9	

Jungle Trail

Table 5. 11: Program formulation: Jungle Trail

S.N.	Component	Nos.	Capacity	Area/Person	Area (m ²)	Remarks
Jungle Trail						
	Green house	1			700	
	Storage	1			50	
	Rest rooms				25	
	Total				775	

Research Laboratory

Table 5. 12: Program formulation: Research Lab

S.N.	Component	Nos.	Capacity	Area/Person	Area (m ²)	Remarks
Administration						
	Account Document, Records	3		7.9	25	
	Reception	1		7.9	25	
	Lab Chief's Office	1		14.8	15	
	Section chief's office	8		12	96	
	Research Scientist office	8		12	96	
	Meeting room	1	10	1.8	18.5	
	Audio Visual Room	1	10	1.8	18.5	
	Staff	2		2.7	55	
	Toilet				25	
	Total				374	

Table 5. 13: Program formulation: Aquatic Lab

S.N.	Component	Nos.	Capacity	Area/Person	Area (m ²)	Remarks
Aquatic Laboratory						
	Nutritional Laboratory	1		31.26	80	
	Water Quality test Lab	1		31.26	80	
	Genetics Laboratory	1		31.26	100	
	Disease lab	1		31.26	100	
	Lecture Hall	1	150	0.9	135	
	Total				495	

Table 5. 14: Program formulation: Lab Support

S.N.	Component	Nos.	Capacity	Area/Person	Area (m ²)	Remarks
	Lab Support					
	Media preparation Room	1		29.7	29.7	
	Incubation Room	1		29.7	29.7	
	Culture room	1		29.7	29.7	
	Sample preparation Room	1		29.7	29.7	
	Total				118.8	

Table 5. 15: Program formulation: Cafe

S.N.	Component	Nos.	Capacity	Area/Person	Area (m ²)	Remarks
	Cafeteria					
	Dining		50	1.1	55	
	Kitchen			40%	22	
	Storage			5%	2.75	
	Snack Bar				30	
	Total				285.75	109.75

Outdoor space: Landscape (150 sq. m), pond(50) & parking

TOTAL AREA = 12860.45 SQ.M

CIRCULATION AND WALL=30% OF TOTAL AREA= 3858.135 SQ.M

TOTAL FLOOR AREA=16718.58 SQ.M

TENTATIVE SITE AREA: 21500 SQ. M (Approx. 42 ropani)

6.0 Concept

6.1 Vision for the project

The project aims to establish a modern-day aquatic environment for both freshwater and marine water species that reinforces the importance of natural environment of the species to maintain the balance of life. Putting the amenities under one roof would provide visitors with a wholesome experience by presenting them with a trip that travels in a planned, sequential path along the thematic display halls. Another key objective was to design architecture that encouraged creativity and open-mindedness to help in the research process.

The site shall remain open to the lake as possible. The mandatory 20m setback from the lake shall be developed as the waterfront plaza, viewing deck and directly accessible via lake's boating transportation. The design shall try to pull the lake into the design as much as possible via the use of decks, artificial ponds and water plazas.

As it is the country's first building of its sort, efforts shall be made to construct an iconic structure that will serve as a symbol for the region, or the entire country once completed.

6.2 Site Context

Before design of any project, the site along with its surrounding must be studied well. The site lies on the northern side of the Fewa lake (Lake side). It is an advantage if a waterfront area is chosen so the site is taken close to Fewa lake but far enough from the city to create a calm, solemn and serene environment. The selection parameters are a tradeoff between high quality environmental conditions and vicinity to a town that will be the potential source of visitors and academic activities.

As lakeside is a prominent tourist attraction, the availability of waterfront spaces can be advantageous and will benefit the aquarium financially. Additionally, because the site is located to the lake, it may serve as a secondary entry via boats, or a boating activity can be linked to the site.

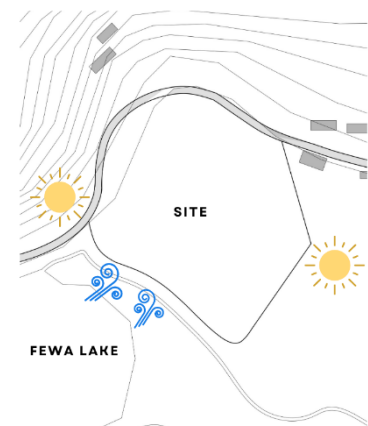

Figure 6. 1: Site with solar and wind path

6.3 Zoning

The zoning of the site is done through two perspectives i.e., from the point of view of function and the other from the privacy of the spaces.

Initially, sufficient setbacks were given, and zones suitable for development were identified.

The public, semipublic and private zoning of site was done. Central area was designed as public zone, western part as private and eastern part as semi-public.

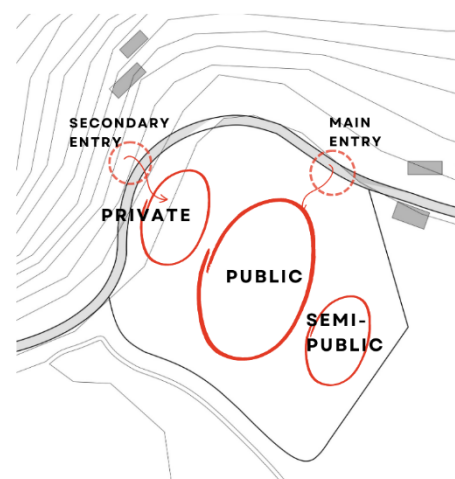

Figure 6. 4: Zoning based on activities

Considering the site being connected to the road from two sides two entries is given: one as the main entry for the public towards north and the other as service entry towards west. The parking is placed at the Eastern side which provides easy access to both research block and main aquarium block.

The main aquarium building is kept at the center. The research center and the fish culture are kept separate from the Aquarium block at the edges to provide a quiet environment and in correspondence to aquarium as research lab and aquarium are related to each other. Similarly, the research center and the dormitory are kept in correspond as the dormitory are the shelter for the staff and the student that works all day long.

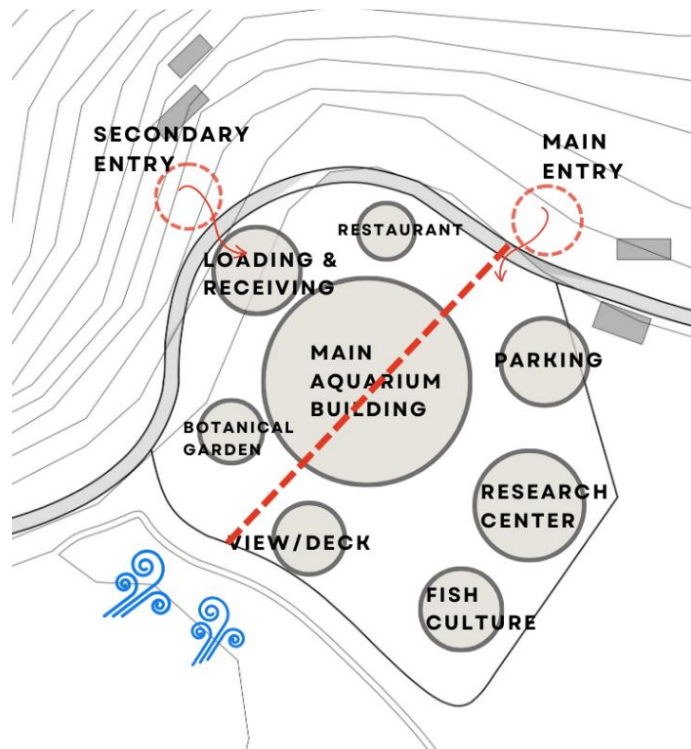

Figure 6. 7: Axis and functions placement (Bubble diagram)

Café is provided near to the entry to facilitate public people. Botanical garden (Water Garden) enclosed in glass house is placed at the southern part. Restaurant is placed at the southern part and connected to the lake area.

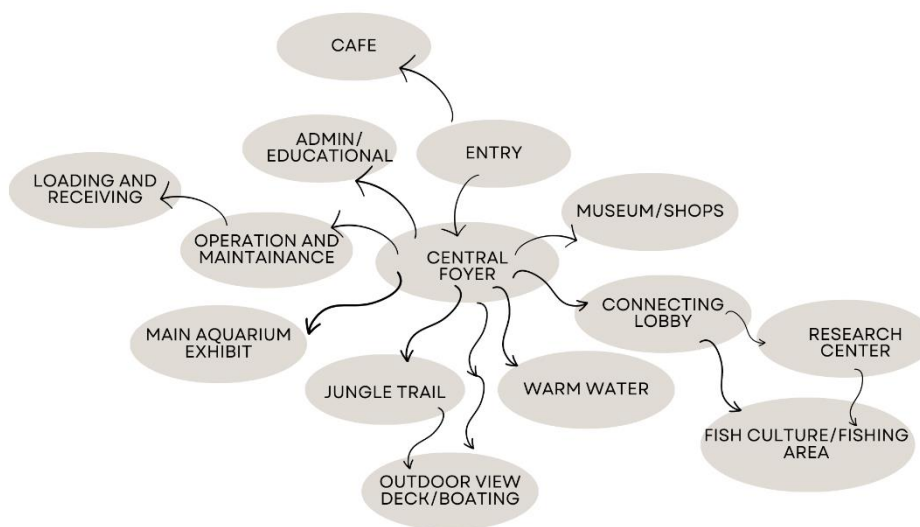

Figure 6. 10: Functional Relationship Diagram

6.4 Concept

A small wave is caused on the surface of a liquid, especially water in a lake, etc. by the wind or something moving in or out on water. We call this little wave a 'Ripple'. So, this little wave is my first approach in design.

Also every water body has different levels. The bottom which is also known as dark part where only little light enters and which houses different strange creatures, then the mid portion where normal fishes swim freely and the top portion which is nowadays degraded by human activities. This is the portion where we find floating wastage. The same theme is included in my design where different floor levels replicate different levels of water with varying exhibition theme which is second approach.

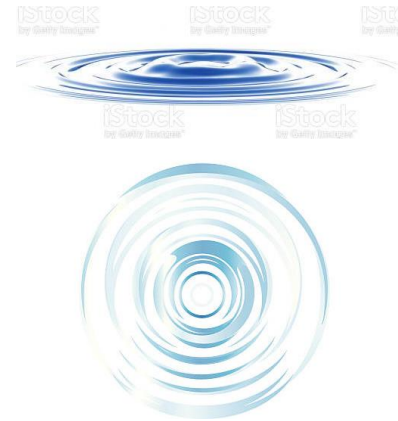

Figure 6.13: Water ripple as concept

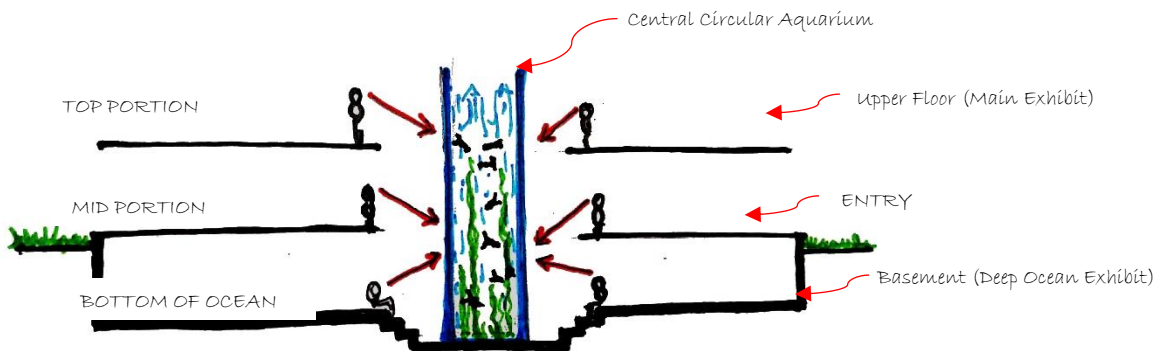

Figure 6.16: Replicating Ocean in building

Initially, the circle pattern that ripple makes is taken for planning which acts as main building.

Then the central foyer which acts as the **center of motion** was placed which connects different functions. This central foyer provides multiple routes and reduces the risk of queues.

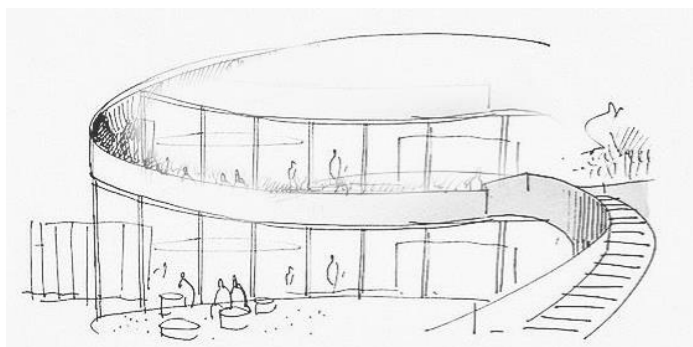

Figure 6.19: Central Foyer space

Different functions were connected to the central foyer. The placement of functions was done such that it suits best for the site. Then those functions were divided among the circle creating 6 different arms; each arm with different theme. All arms connected to a central foyer from which the public can access the exhibitions independently from one another.

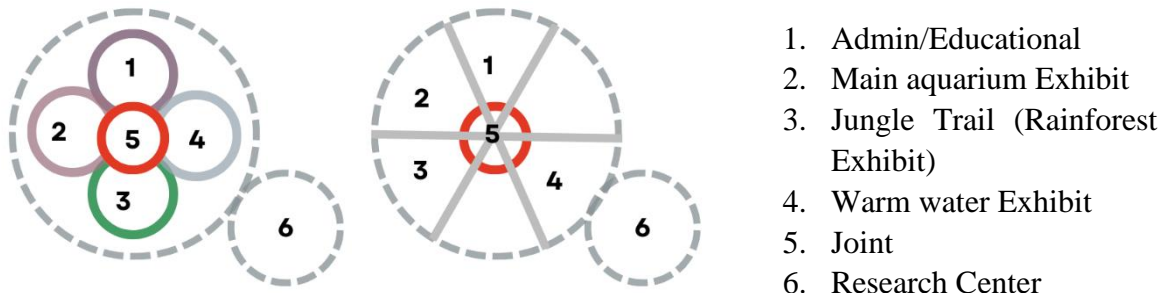

Figure 6. 22: Planning approach

The Jungle Trail was provided with elevated walkways from which one can view the rainforest from ground level as well as through elevated walkways.



Figure 6. 25: Elevated walkways in Jungle

6.5 Exhibition Themes

The exhibition hall shall be arranged in different themes with predefined circulation pattern for most of the galleries. Each hall has different themes showcasing aquatic life of different environment. Nevertheless, different circulation paths have been created to alleviate overcrowding and monotony while also offering visitors with alternatives when walking about and presenting an alternative view of the galleries.

Jungle Trail:

This glass house consists of live rainwater forest plant species as well as aquatic life. Rainforests are responsible for rainfall which also symbolizes the beginning of the journey of water in land.

Deep ocean Exhibit:

This exhibit is placed at the basement which consists of display of deep ocean fishes and this area is dark themed to show the deep ocean.

Coral reef:

It consists of tanks which displays live corals and other species relating to corals reefs.

Tunnel Tank:

These are the acrylic tunnels for visitors to pass through. The tank exhibits marine as well as brackish water species. Visitors can feel as if they are under the water.

Central Circular Tank:

This is three story Acrylic cylindrical tank that starts from basement and welcomes the visitors which houses schooling fishes in enormous number. This is the first tank that visitors see when they enter the building.

6.6 Detailed Design Development**6.6.1 Entry & Landscape**

Multiple entrance has been provided one from the northern side for vehicular and pedestrian entry. Additionally, Since the site opens to the lake from southern side it serves as a secondary entry via boats. Lake viewing Deck connects the lake and restaurant from which one can enjoy the mesmerizing view of the Fewa lake. This deck also leads to the central foyer of the main block. Towards the right side of pedestrian entry artificial water stream is provided which is linked with the café area. For regular, casual guests who wish to get a quick meal and some drinks, there is a café section available. They also benefit from a lovely landscape.

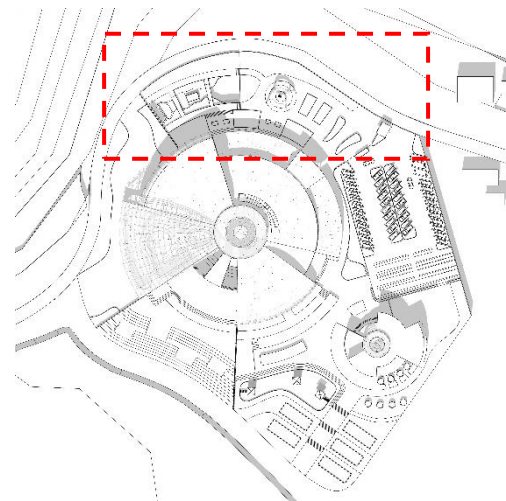

Figure 6. 28: Entry and Landscape

6.6.2 Admin Block

Entry from front leads to the ticket counter/reception. One can see the hanging fishes in the ceiling which also leads the way to the central foyer. This block consists of orientation hall, activity hall and mini theater in the ground floor which is the first place where visitors are taken to. In the activity hall different games are played like river dance, fish draw and many more. Upper floor of this block has administration and Library, so its entry is made separate for dedicated users.

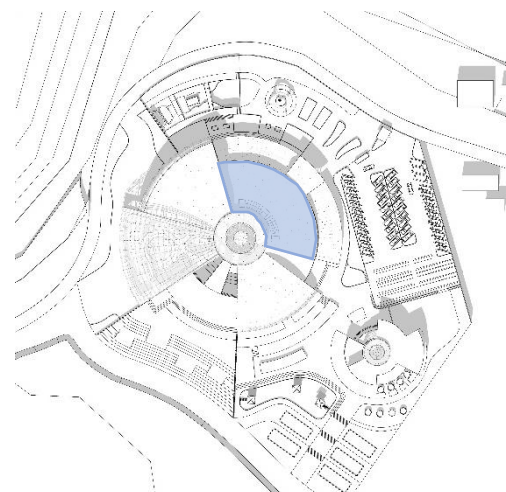

Figure 6. 31: Admin block

6.6.3 Aquarium Block A

This 3 story block is the primary aquarium block as well. Entry leads the visitors to the central foyer and the journey begins from the basement. The dark motif in the basement is meant to evoke the deep, dark ocean. The deep ocean displays are fun for visitors. Also, the central circular tank can be viewed from the basement as well as all upper floors. Next one enters the two-story tunnel tank, which will have a large community habitat where marine animals will be shown. Additional viewing panels add to the aquarium's wow effect. Every upper floor displays various species that represent the bottom, middle, and top portions of the ocean. Every floor is accessible via central foyers stair.

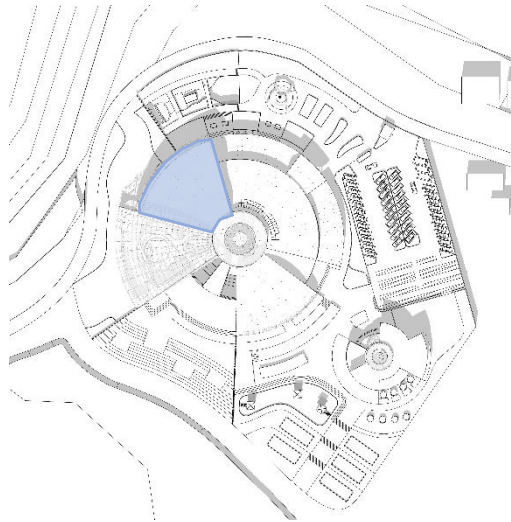

Figure 6. 32: Aquarium Block A

6.6.4 Jungle Trail

The jungle route, which features freshwater fish in ponds and diverse plants resembling an amazon forest, begins as you exit block A. This is a completely glass building that can be seen from high walkways as well as from the ground. Elevated walkway is accessible from first floor and the trail can be viewed from central foyer of all above levels.

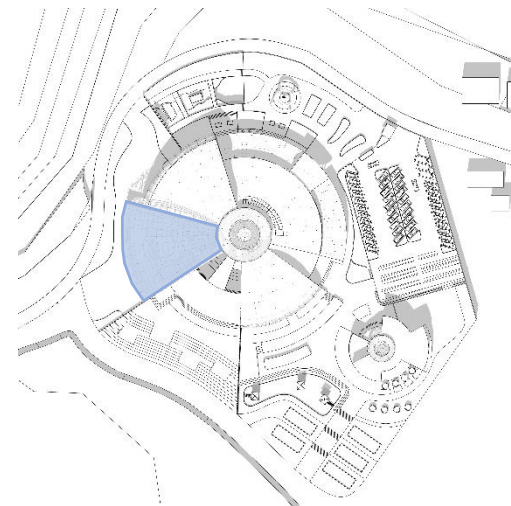

Figure 6. 33: Jungle Trail

6.6.5 Lake View Restaurant

Visitors may access the outdoor lake view platform via the forest walk, where they can enjoy the stunning lake view. Also, this area serves as a link between the lake and the site. This area serves as a secondary entry for visitors arriving by boat from the lake. Visitors has been provided with the provision of boating on the magnificent Fewa lake. Also the restaurant is located on the first floor, where guests may eat while taking in the magnificent lake view. The restaurant and the central foyer on the first level are connected by a bridge.

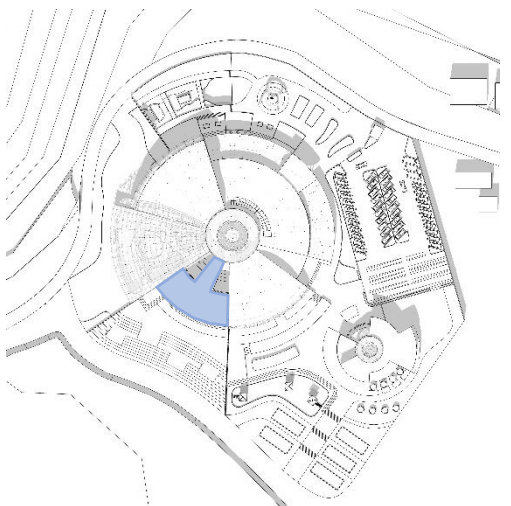

Figure 6. 34: Restaurant area

6.6.6 Aquarium Block B

Visitors enter the two-story Aquarium block B via the central foyer after their outside excursion to the lake viewing deck. The tank view theater is this exhibit's major draw. One may view the impressive double height glass aquarium while sitting on the sunken decks. This aquarium may also be observed from the first floor, allowing people to interact visually. Other, smaller aquariums with a variety of species are also on display.

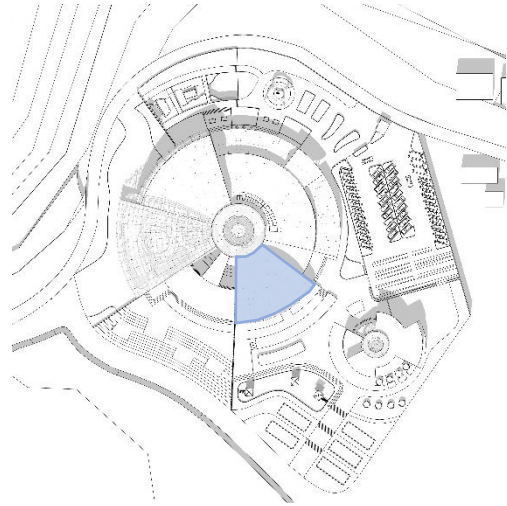

Figure 6. 35: Aquarium Block B

6.6.7 Joint block

On the main floor of this two-story building are the ticket counter, museum, shops, and exit. On the first floor are the competition hall, multipurpose hall, and children's play area. Visitors arriving for events or competitions in the multipurpose hall can access the building straight from the exit leading to the multipurpose hall by steps.

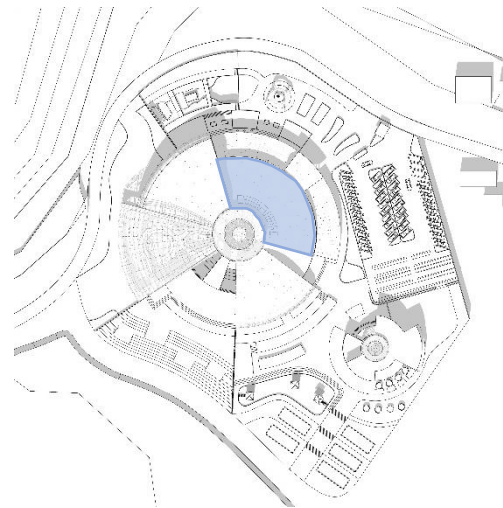

Figure 6. 36: Joint Block

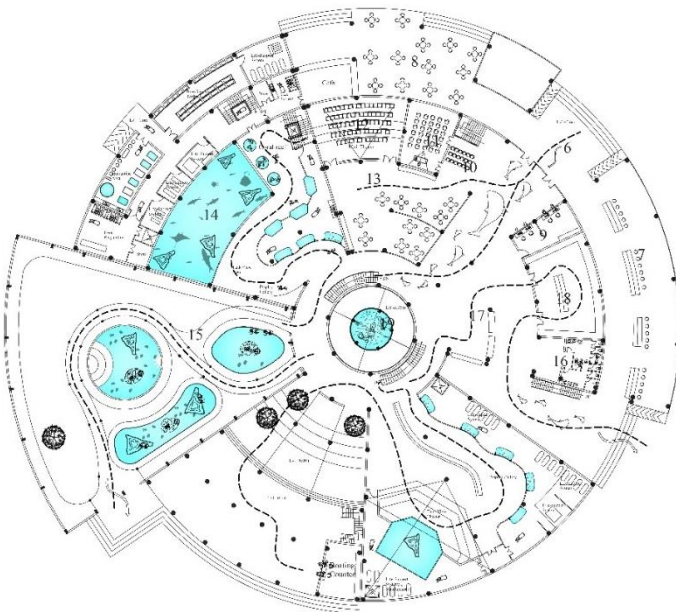

Figure 6. 37: Circulation Diagram (Ground Floor)

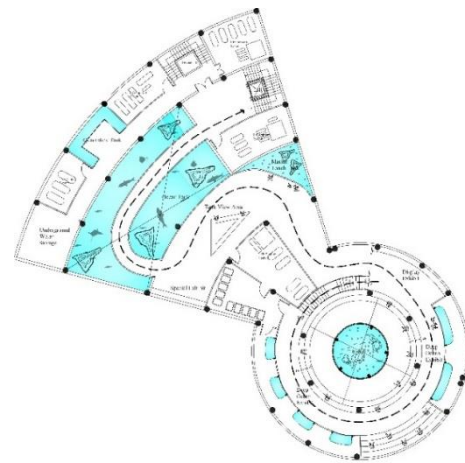

Figure 6. 40: Circulation Diagram (Basement)

6.7 Area Analysis:

1. MAIN AQUARIUM BLOCK:

GROUND FLOOR: 5865.17 sq. m

Central Foyer: 257.64 sq. m

Jungle Trail: 1170.9 sq. m

Café: 312 sq. m

Admin Block: 479 sq. m (GF)

Theater: 130 sq. m

Orientation Hall: 66 sq. m

Activity Hall /Waiting Area/Services: 283 sq. m

Museum/Reception/Shop: 260 sq. m

Main Aquarium Block A: 975.36 sq. m (GF)

Services & Life Support Systems: 444.9 sq. m

Display Gallery & Maintenance area: 530.4 sq. m

Aquarium Block B: 736.2 sq. m (GF)

2. RESEARCH BLOCK:

GROUND FLOOR: 592 sq. m

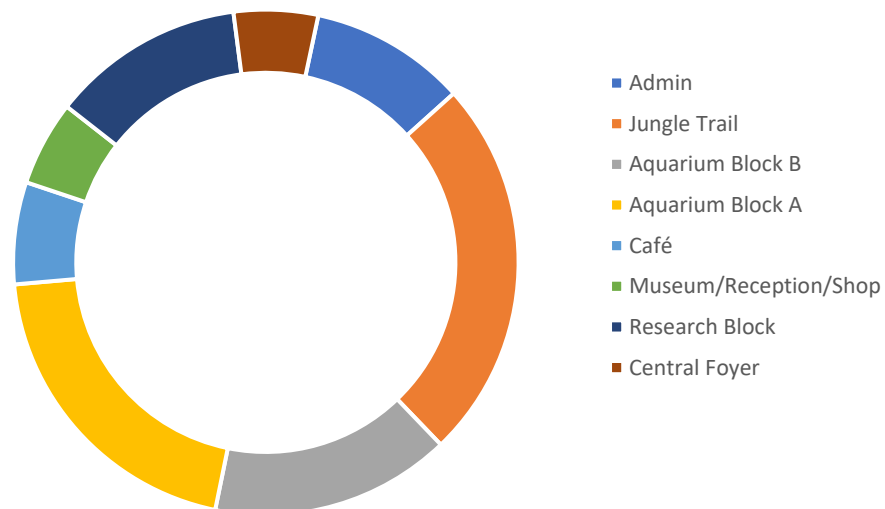
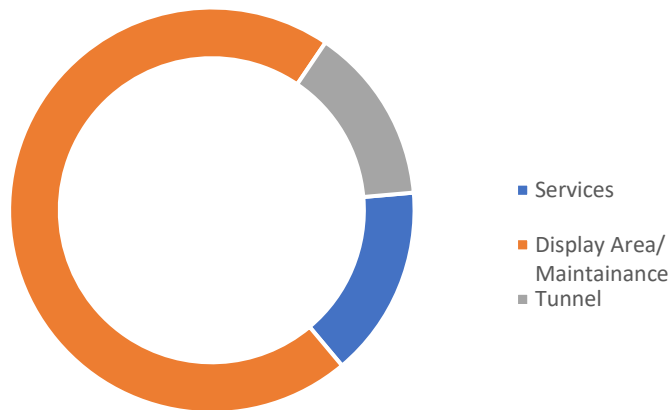

Figure 6. 41: Ground Floor Area Analysis

1. MAIN AQUARIUM BLOCK:**BASEMENT FLOOR: 1401.53 sq. m****Services: 214.2 sq. m****Display Area/Maintenance: 989 sq. m****Tunnel: 198 sq. m***Figure 6. 42: Basement Area Analysis***1. MAIN AQUARIUM BLOCK:****FIRST FLOOR: 3775.62 sq. m****Central Foyer: 257.64 sq. m****Jungle Trail: 1170.9 sq. m****Restaurant: 507.3 sq. m****Admin Block: 560.8 sq. m (FF)****Library: 290.74 sq. m****Administration: 273.7 sq. m****Multipurpose Hall: 176 sq. m****Competition Hall: 60 sq. m****Main Aquarium Block A: 975.36 sq. m (GF)****Services & Life Support Systems: 444.9 sq. m****Display Gallery & Maintenance area: 530.4 sq. m****Aquarium Block B: 487.08 sq. m (FF)**

2. RESEARCH BLOCK:

FIRST FLOOR: 509 sq. m

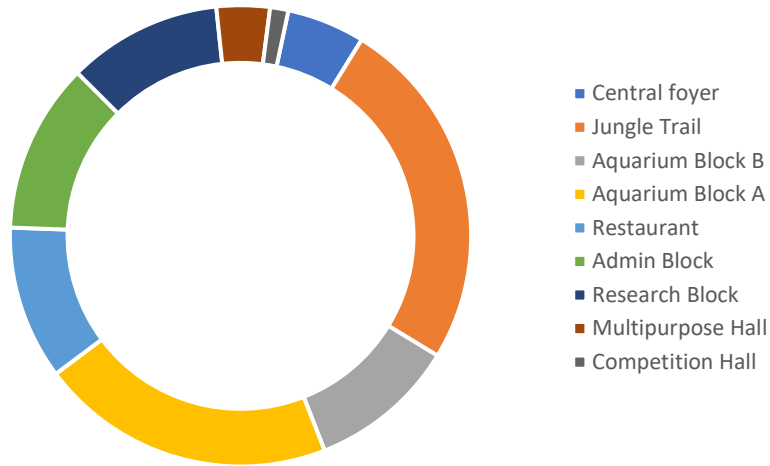

Figure 6. 43: First floor Area Analysis

1. MAIN AQUARIUM BLOCK:

SECOND FLOOR: 1279.46 sq. m

Main Aquarium Block A: 975.36 sq. m (GF)

Services & Life Support Systems: 444.9 sq. m

Display Gallery & Maintenance area: 530.4 sq. m

Central Foyer: 257.64 sq. m

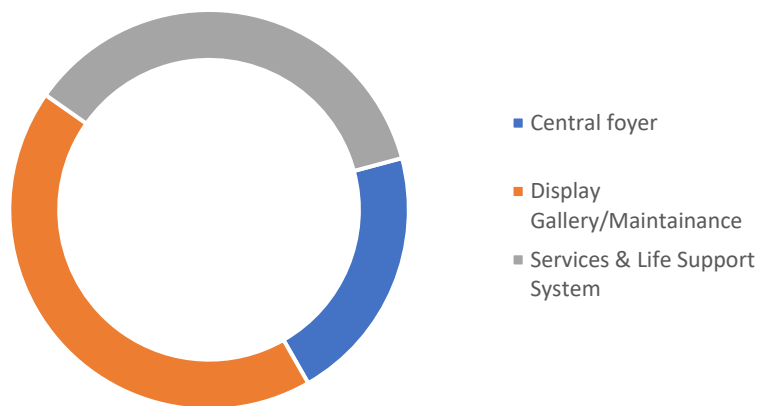

Figure 6. 44: Second Floor Area Analysis

Total Built up Area: 13422.78 sq. m

Total Plinth Area: 6457.17 sq. m (30.03% of site area)

Site area: 21500 sq. m (Approx. 42 ropani)

7.0 Services

7.1. Water Supply

Water in the site is collected from the municipal water supply line and from Fewa lake. Separate underground tank is provided for different aquarium blocks. The underground water tank is provided at the basement of the display area with a separate tank for the aquatic. The water is then supplied to different levels for different purpose through pressure pump system. No overhead tank is provided and all water supply is done through outdoor and indoor underwater tanks using pressure pumps.

Calculation For underground tank

Water requirement for species

Block A= 200000 liters

$1 \text{ m}^3 = 1000 \text{ l}$

Volume (V) = 200 m^3

Indoor Underground Water tank-1 size= $10\text{m} \times 7\text{m} \times 3\text{m} = 210 \text{ cu. m}$

Block B= 100000 liters

$1 \text{ m}^3 = 1000 \text{ l}$

Volume (V) = 100 m^3

Indoor Underground Water tank-2 size= $8\text{m} \times 5\text{m} \times 3\text{m} = 120 \text{ cu. m}$

Administration

Water requirement = 45 l / c / d

People = 35

Requirement = $45 \times 35 = 1575 \text{ l / d}$

Café

Water requirement = 50 l / c / d

People = 52

Requirement = $50 \times 52 = 2600 \text{ l / d}$

Restaurant

Water requirement = 50 l / c / d

People = 90

Requirement = $50 \times 90 = 4500 \text{ l / d}$

Research lab

Water requirement = 100 l / c / d

People = 35

Requirement = $100 \times 35 = 3500$ l/d

Multipurpose hall

Water requirement = 15 l/c/ d

People = 80

Requirement = $15 \times 80 = 1200$ l/d

Library

Water requirement = 20 l/c/ d

People = 50

Requirement = $20 \times 50 = 1000$ l/d

Table 7. 1: Daily water consumption Calculation

PARTICULARS	NO. OF USERS	LPCD	TOTAL
ADMIN	35	45	1575
CAFE	52	50	2600
RESTAURANT	90	50	4500
MULTIPURPOSE HALL	80	15	1200
LIBRARY	50	20	1000
RESEARCH LAB	35	100	3500
TOTAL	342		14375

Total visitors per day= 500

Water requirement =15 l/c/d

Requirement= $500 \times 15 = 7500$ l/d

Total= 14375 l/d + 7500 l/d = 21875 liters/day = $21.875 \text{ m}^3 \times 3$ (safety factor) = 65.625 m^3

Fire Hazard=50,000 liters (NBC)= 50 m^3

Total Underground water tank= $115.625 \text{ m}^3 + 200 \text{ m}^3$ (Pond Area)= 315.625 m^3

Outdoor Underground Water tank size provided= $81.2 \text{ m}^2 \times 4 \text{ m} = 324.8 \text{ cu. m}$ (Provided)

Indoor Underground Water tank-1 size (Tunnel Block) = $10 \text{ m} \times 7 \text{ m} \times 3 \text{ m} = 210 \text{ cu. m}$ (Provided)

Indoor Underground Water tank-2 size (View theater Block) = $8 \text{ m} \times 5 \text{ m} \times 3 \text{ m} = 120 \text{ cu. m}$ (Provided)

7.2. Sanitary

One septic tank shares the sewerage of research block and Aquarium block. Two Soak pit are provided one for the sewerage from display gallery and the other from septic tank.

Calculation of septic tank:

Table 7. 2: Number of Users Calculation

PRIMARY USERS		SECONDARY USERS	
ADMIN	35	CAFE	52
RESEARCH LAB	35	RESTAURANT	90
		MULTIPURPOSE HALL	80
		LIBRARY	50
		VISITORS	500
Total	70	Total	772
		(20% of total)	155

Total number of users=225

Volume of Septic Tank required= No. of users* 3 cu. ft.

$$= 225 \times 3 \text{ cu.ft}$$

$$= 675 \text{ cu.ft}$$

$$= 19.11 \text{ m}^3$$

Hence,

No. of Septic tank = 1

Volume of each septic tank=19.11 m³

Assuming the height of septic tank = 3m

$$L \times B \times H = 19.11 \text{ m}^3$$

$$3B \times B \times 3 = 19.11 \text{ m}^3$$

$$B = 1.4 \text{ m}, L = 3 \times 2.8\text{m} = 4.3\text{m}$$

Septic Tank Size = 4.3m x 1.4m x 3m

Size of soak pit = 2 x sp.6 (Sp.6 = Dia. 5m and depth 2.75) from standard

8.0 3D Visualization

8.1 3D Visualization



Figure 8. 1 View from Entrance



Figure 8. 2: Cafe Area



Figure 8. 3: Running water Stream



Figure 8. 4: Entry Landscape/ Water Plaza



Figure 8. 5: Pond Area/Fish Culture



Figure 8. 6: View of building from Parking

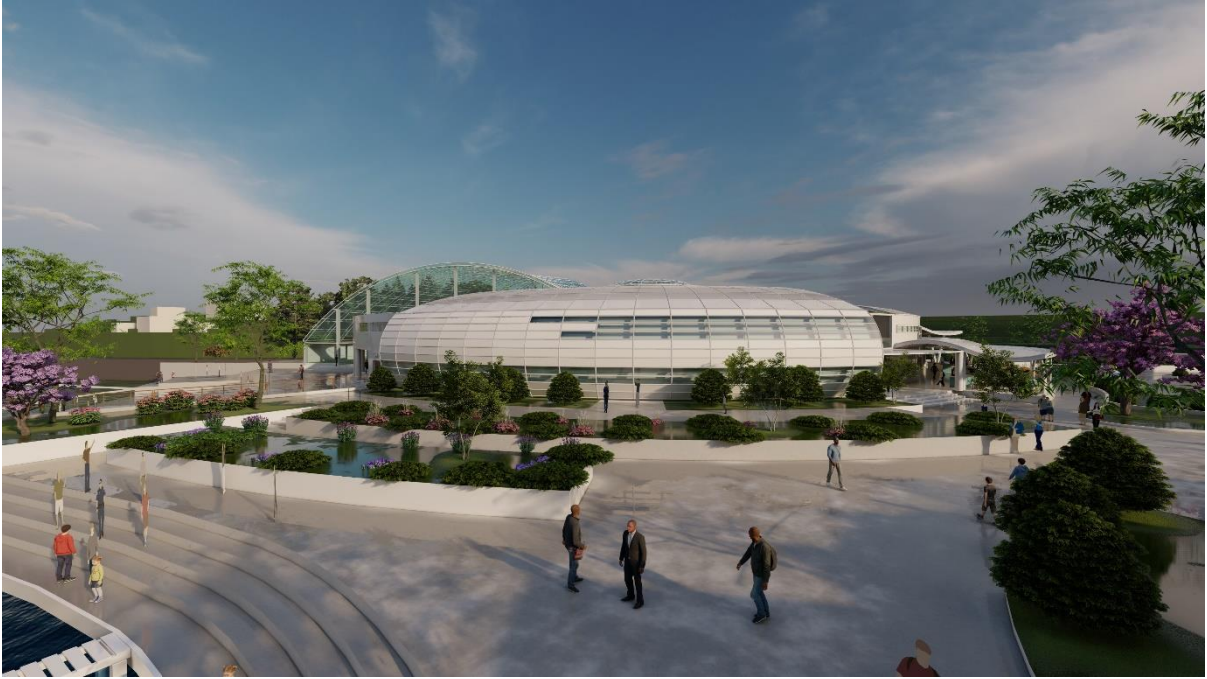

Figure 8. 7: Fishing area and Landscape towards exit



Figure 8. 8: Fishing Pond Area



Figure 8. 9: Lake side View Deck



Figure 8. 10: Ariel View from Pond side



Figure 8. 11: Tank View Area (Basement)

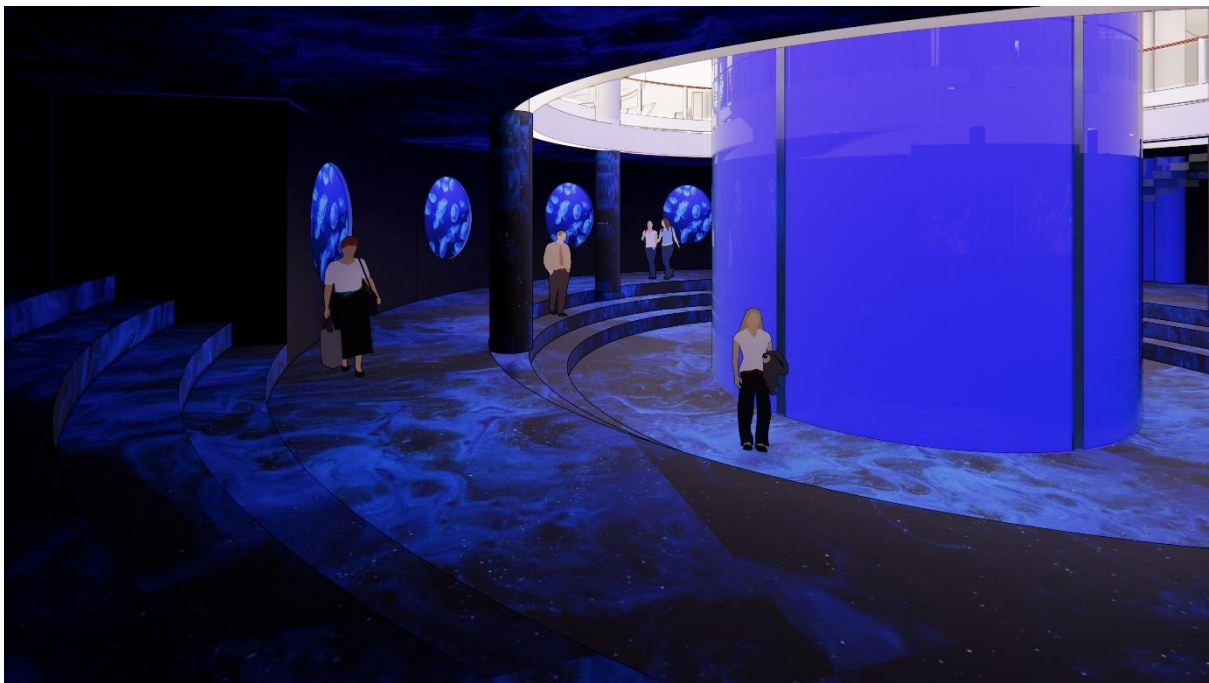

Figure 8. 12: Deep Ocean Exhibit

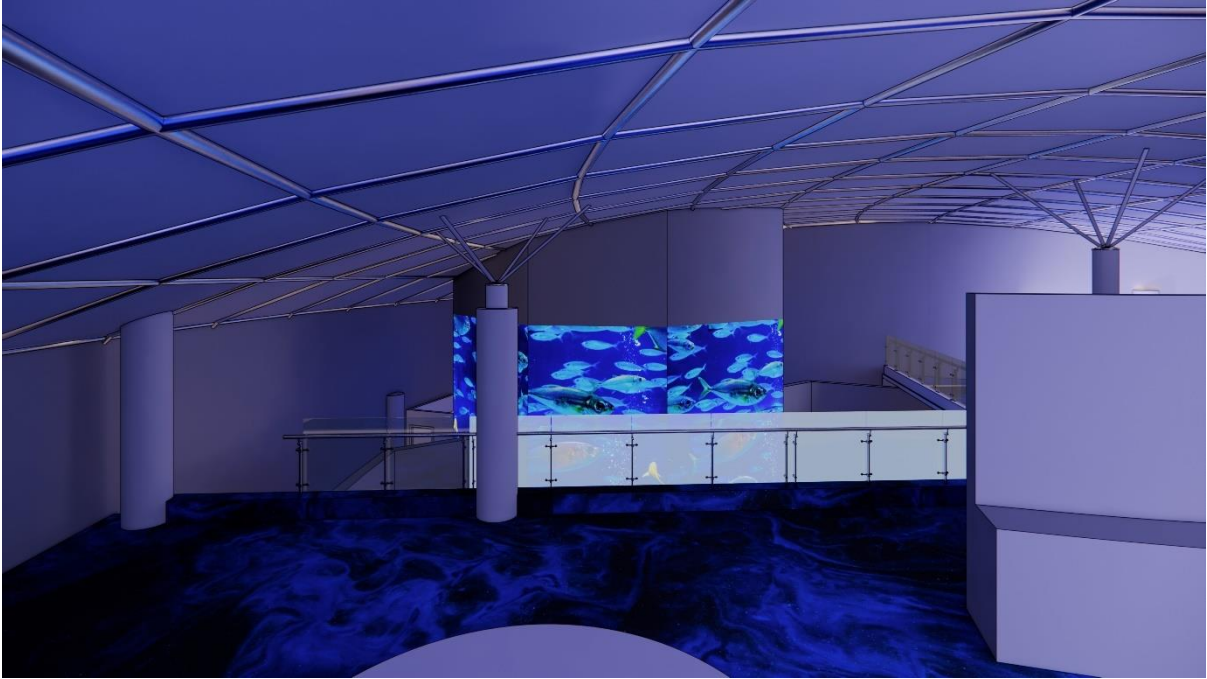

Figure 8. 13: Tank View Theater

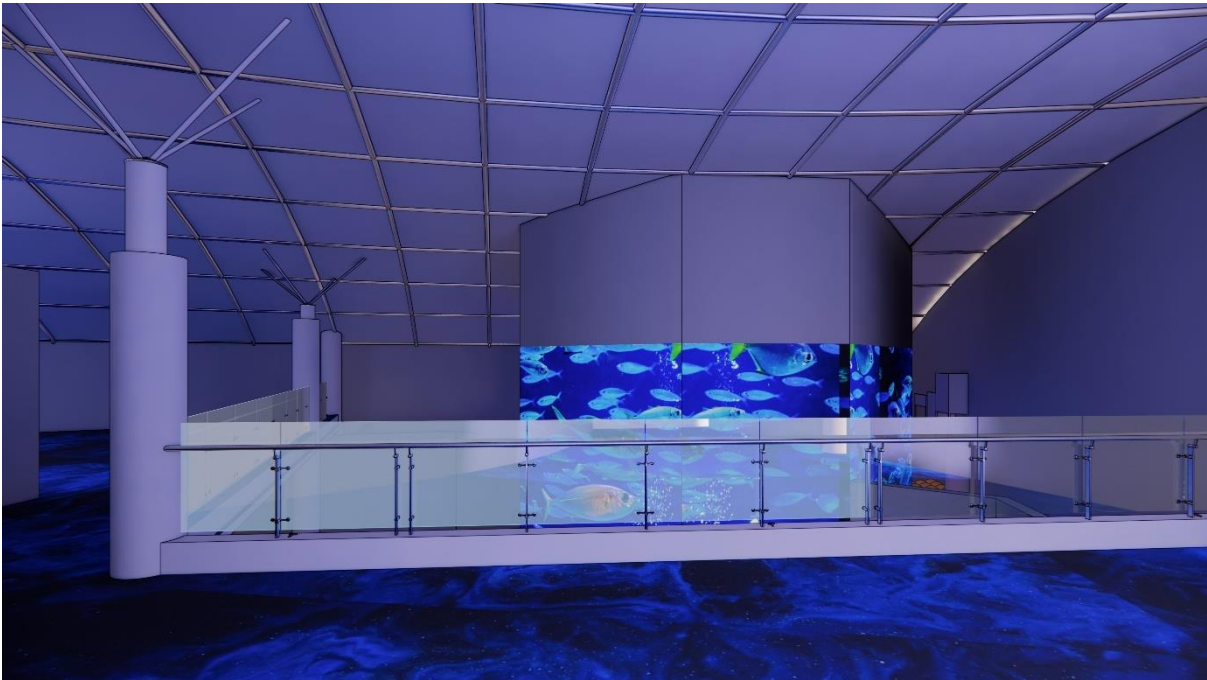

Figure 8. 14: Tank View Theater

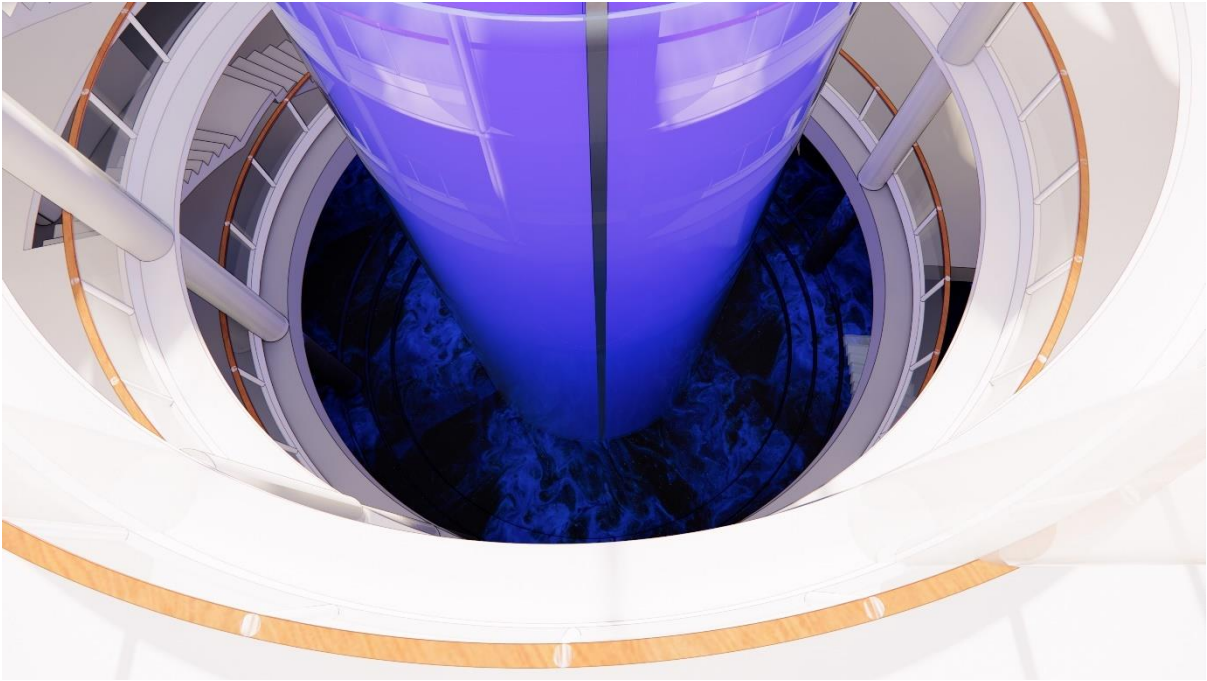

Figure 8. 15: Central Foyer with circular tank



Figure 8. 16: Jungle trail

8.2. Physical Model

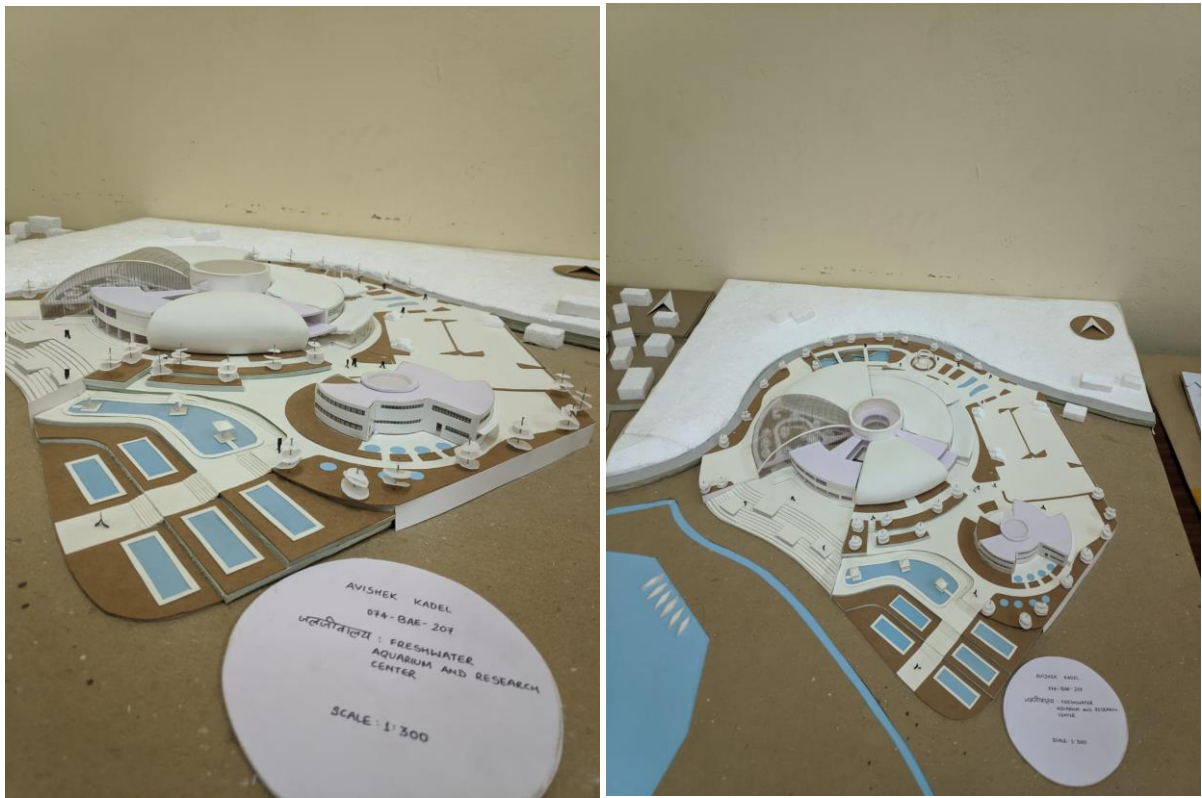

Figure 8.17: Ariel view from pond Area



Figure 8.18: View from Lake side area

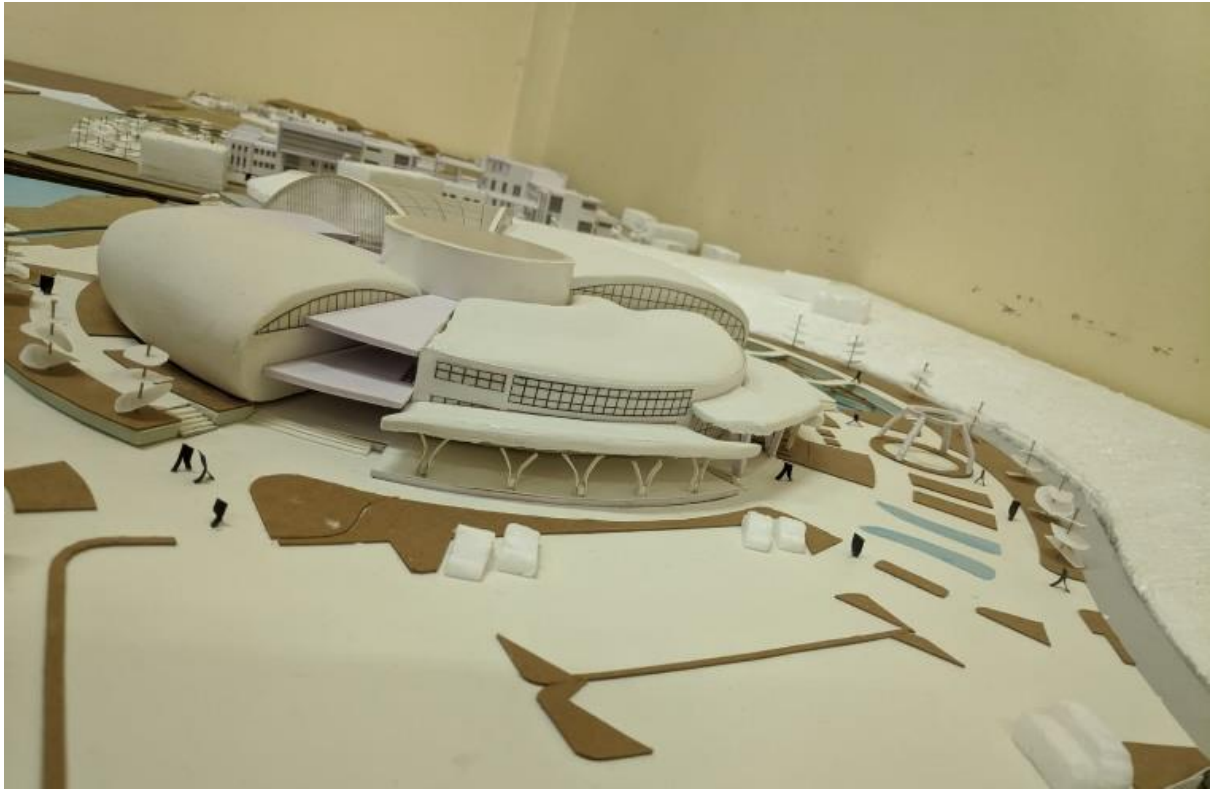

Figure 8. 19: Parking and Entry

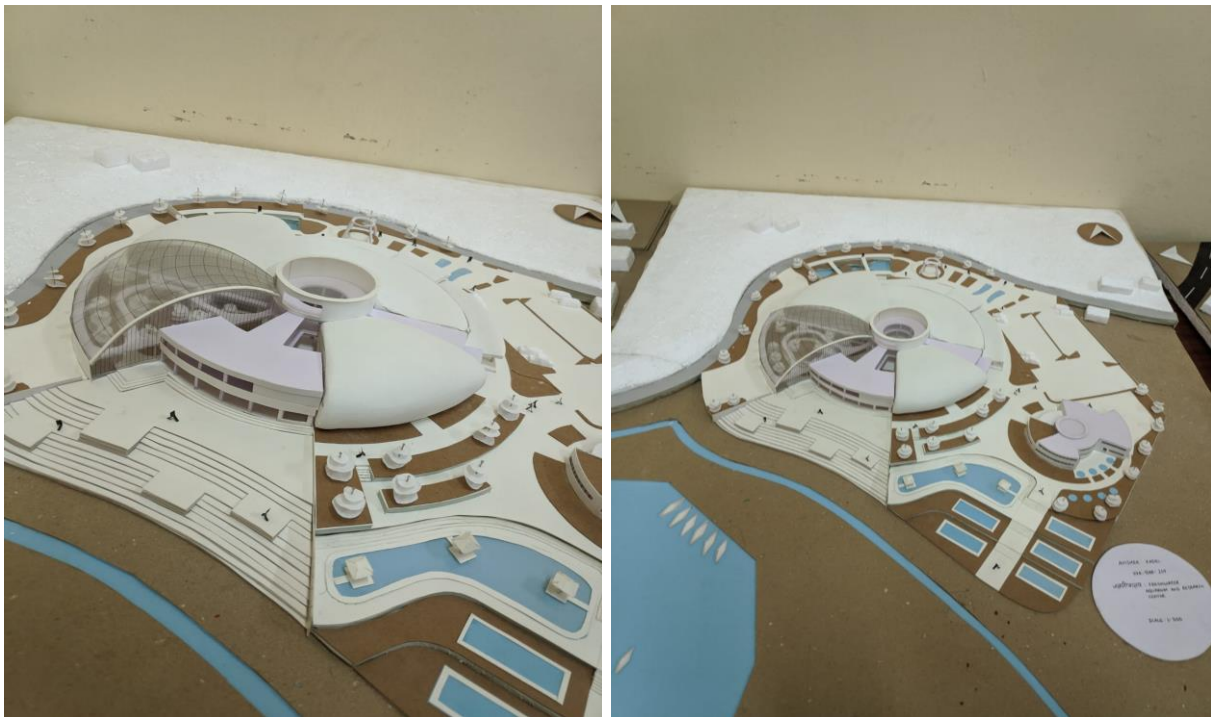

Figure 8. 20: Ariel View

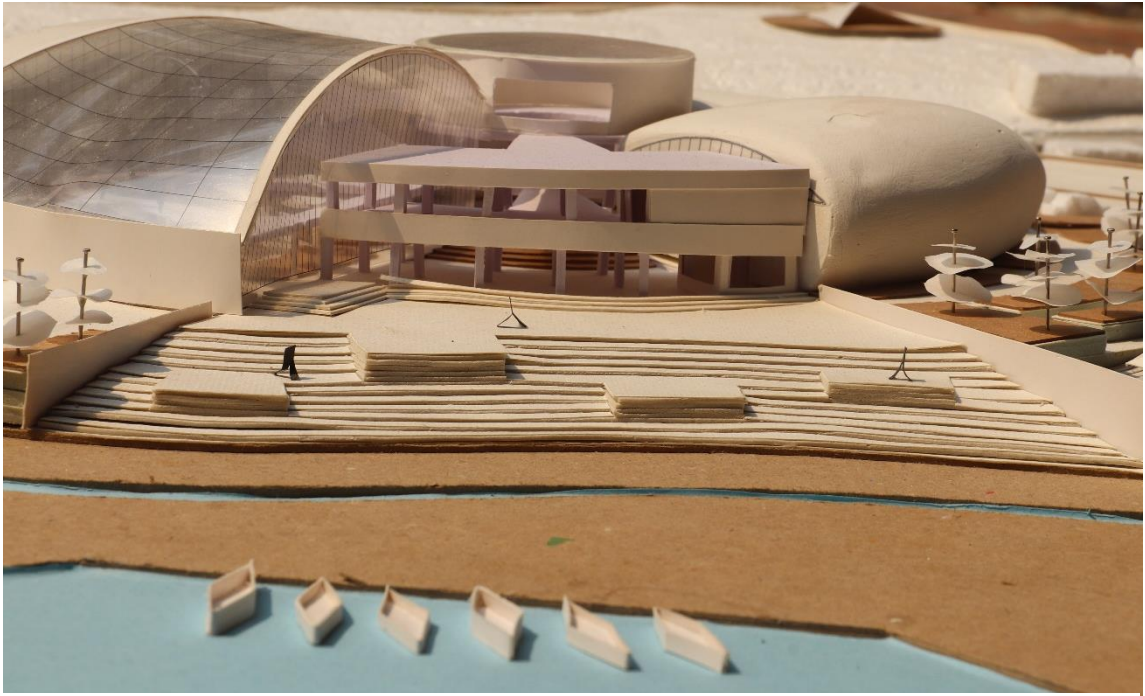

Figure 8.22: View deck and Restaurant area



Figure 8.24: Pond Area



Figure 8.27: Entry Landscape (Running Stream)



Figure 8.26: Lake view deck

9.0 References

- Adamson, M. (2004). Food in medieval times. *Westport, Conn, Greenwood Press*, 42.
- advanced-aquariums.com. (2020). Top seven benefits of public aquariums.
- Aquarium Fish Magazines. (1996). *Aquarium Fish Magazines*, 49.
- Chira, J. &. (1983). Time-Saver Standards for building types. *Mcgraw Hill International Editions*.
- Delbeek, J. &. (2005). The reef aquarium science, art et technology. *Coconut Grove (Florida), Ricordea Publishing*.
- Helfman, G. (2007). Fish Conservation: a guide to understanding and restoring global aquatic biodiversity and fishery resources. *Washington, Island Press*.
- Hemdal, J. (2003). Aquarium fish Breeding. *N.Y, Barron's*, 8.
- Hibberd, S. (2017). The Aquarium and Water-Cabinet. *Nikosia, TP Verone Publishing*.
- Karydis, M. (2011). ORGANIZING A PUBLIC AQUARIUM: OBJECTIVES, DESIGN, OPERATION AND MISSIONS. A REVIEW. *Global NEST*, 369-384.
- Kisling, V. N. (2001). Zoo and Aquarium history: ancient animal collections to zoological gardens. *CRC Press*.
- Kratochvil, H. &. (1997). Reducing acoustics disturbances by aquarium visitors. *Zoo Biol*, 349-353.
- liveaquaria.com. (2022). The importance of Quarantine tank. *LiveAquaria*.
- Richardo Calado, I. O. (2017). Marine ornamental species aquaculture. *WileyBlackwell*, 4.
- scaquarium.org. (2011). Saltmarsh Aivary. *South Carolina Aquarium*.
- Settlement, M. o. (n.d.). *GUIDELINES FOR DIFFERENTLY-ABLED FRIENDLY* . The Engineering Services Division.
- Tamrakar, J. (2012). AQUA RESEARCH AND PROMOTION CENTER. *Kathmandu: Tribhuvan University Press*.
- Taylor, L. R. (1993). Aquariums: Windows to Nature. *Prentice Hall General Reference, New York*.
- Amatya, S., Shrestha, B., 1967. Economic Geography of Nepal. Badi Pyari Amatya, Lalitpur, Nepal.
- Public Aquarium (2022, January 11). In wikipedia https://en.wikipedia.org/wiki/Public_aquarium
- Freshwater Aquarium (2021, February 18). In wikipedia https://en.wikipedia.org/wiki/Freshwater_aquarium
- e Sharma, Chhatra M.(2008)'Freshwater fishes, fisheries, and habitat prospects of Nepal',Aquatic Ecosystem Health & Management,11:3,289 — 297

ANNEX