



TRIBHUVAN UNIVERSITY

INSTITUTE OF ENGINEERING, PULCHOWK CAMPUS

A FINAL YEAR PROJECT

REPORT ON

**“MULTI BATTERY BLOCK MODULE POWER CONVERTER FOR ELECTRIC
VEHICLE DRIVEN BY SWITCHED RELUCTANCE MOTOR”**

PROJECT MEMBERS

NILESH SAH SONAR (075BEL026)

SITARAM KARKI (075BEL043)

SWASTIKA POKHAREL (075BEL045)

VIBEK GHIMIRE (075BEL048)

PROJECT SUPERVISOR

Asst.Prof. Ganesh Bhandari

Department of Electrical Engineering

SUBMITTED TO:

Department of Electrical Engineering

March 2023

TRIBHUVAN UNIVERSITY
INSTITUTE OF ENGINEERING
PULCHOWK CAMPUS
DEPARTMENT OF ELECTRICAL ENGINEERING

The undersigned certify that they have read, and recommended to the Institute of Engineering for acceptance, a project report entitled "MULTIBATTERY BLOCK MODULE POWER CONVERTER FOR ELECTRIC VEHICLE DRIVEN BY SWITCHED RELUCTANCE MOTOR" submitted by "NILESH SAH SONAR, SITARAM KARKI, SWASTIKA POKHAREL, VIBEK GHIMIRE" in partial fulfilment of the requirements for the Bachelor's degree in Electrical Engineering.

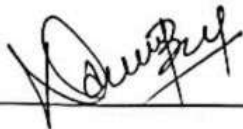

Asst. Prof. Ganesh Bhandari
Supervisor
Department of Electrical Engineering



Asst. Prof. Yubraj Adhikari
Head of the Department
Department of Electrical Engineering



Asst. Prof. Dr. Bishal Silwal
External Examiner
Department of Electrical and Electronics
Engineering
Kathmandu University

COPYRIGHT

The authors have agreed that the library, Department of Electrical Engineering, Central Campus, Institute of Engineering may make this report freely available for inspection. Moreover, author has agreed that permission for extensive copying of this project report for scholarly purpose may be granted by the professor(s) who supervised the project work recorded herein or, in their absence, by the Head of the Department wherein the project report was done. It is understood that the recognition will be given to the author of this report and to the Department of Electrical Engineering, Central Campus, and Institute of Engineering in any use of the material of this project report. Copying or publication or the use of this report for financial gain without approval of the Department of Electrical Engineering, Central Campus, Institute of Engineering and author's written permission is prohibited

Request for permission to copy or to make any other use of the material in this report in whole or in part should be addressed to:

The Head

Department of Electrical Engineering

Institute of Engineering (IOE)

Pulchowk Campus

Lalitpur, Nepal

ACKNOWLEDGEMENT

Firstly, we would like to express our deep gratitude to our Supervisor **Asst. Prof. Ganesh Bhandari** for his patience, motivation, and continuous support in our project. We could not have imagined a better advisor and mentor.

We would like to express our due respect to **Assoc. Prof. Yubraj Adhikari**, Head of the Electrical Engineering Department for his valuable and kind support. Our sincere thanks go to all the professors and lecturers of the department for their precious suggestions and kind support throughout the project duration.

We extend our special thanks to all the **department staff, Madhusudan sir**, and our **friends and families** for their endless support.

Project Members

Nilesh Sah Sonar (075BEL026)

Sitaram Karki (075BEL043)

Swastika Pokharel (075BEL045)

Vibek Ghimire (075BEL048)

ABSTRACT

This project proposes an innovative approach to control and regenerate energy from a switched reluctance motor (SRM) for electric vehicles using a multi-battery system. By adopting this configuration, the proposed system overcomes the limitations of a single battery pack and maximizes the potential of the SRM.

The control system implemented in this project utilizes a proportional-integral (PI) controller, which is carefully optimized to ensure efficient operation and minimize losses. The PI controller plays a crucial role in maintaining the desired performance of the SRM while achieving optimal energy regeneration. Through simulation on a 75 kW SRM, the results of this project exhibit significant enhancements in performance compared to traditional control methods. Notably, an impressive 26% of energy regeneration is achieved, which greatly contributes to the overall efficiency of the system.

To complement the multi-battery setup, a sophisticated BMS is incorporated into the proposed system. The BMS acts as a monitoring and control unit, continuously assessing the state of charge (SOC) and temperature of each individual battery pack. This data-driven approach enables the system to intelligently switch between battery packs based on their specific conditions. By doing so, the system ensures optimal utilization of each battery pack, preventing overcharging or over-discharging, and ultimately prolonging the lifespan of the batteries.

Moreover, the proposed system features a regenerative braking system, which capitalizes on the SRM's capability to generate energy during deceleration and braking. This regenerative braking mechanism converts the kinetic energy of the vehicle into electrical energy, which is then stored in the battery packs for future use. This additional energy recovery further enhances the system's overall efficiency and contributes to the sustainable operation of electric vehicles.

One of the remarkable advantages of the proposed system is its scalability. As new batteries with improved capabilities become available, the multi-battery system can be easily upgraded or replaced, ensuring that the electric vehicle remains at the forefront of efficiency and performance.

TABLE OF CONTENTS

PAGE OF APPROVAL.....	II
COPYRIGHT.....	III
ACKNOWLEDGEMENT.....	IV
ABSTRACT.....	V
TABLE OF CONTENTS.....	VI
LIST OF ABBREVIATIONS.....	VII
LIST OF FIGURES.....	VIII
CHAPTER ONE : INTRODUCTION.....	1
1.1 Background.....	1
1.2 Problem Statement.....	2
1.3 Objective.....	3
1.4 Scope of the Project.....	3
1.5 Project Layout.....	4
CHAPTER TWO : LITERATURE REVIEW.....	5
2.1 Review of Related Research Articles.....	5
2.2 Switched Reluctance Motor.....	6
2.3 MATLAB.....	9
2.4 Simulink.....	11
2.5 Battery.....	13
2.6 IGBT.....	14
2.7 Diode.....	15
2.8 Capacitor.....	16
2.9 Inductor.....	17
CHAPTER THREE: METHODOLOGY.....	19
3.1 Flowchart.....	19
3.2 Selection of SRM.....	19
3.3 Control Circuit.....	21
3.4 Multiple Battery Module.....	22
3.5 Breaker.....	23
3.6 MATLAB Function Block.....	24

3.7 Control Block Diagram of SRM.....	25
3.8 Circuit Diagram in SIMULINK.....	26
CHAPTER FOUR: RESULT AND DISCUSSION.....	30
CHAPTER FIVE: CONCLUSION AND RECOMMENDATIONS.....	33
REFERENCES.....	35
APPENDIX A : Circuit Diagram in Multisim.....	36

LIST OF ABBREVIATIONS

AC	-Alternating Current
AHB	-Asymmetrical Half-Bridge
DC	-Direct Current
MBM	-Multi-Battery Block Module
PV	-Photovoltaic
PWM	-Pulse Width Modulation
SRM	-Switched Reluctance

List of Figures

Figure 1.1 The electric vehicle drive system	2
Figure 2.1 Block Diagram of SRM.....	6
Figure 2.2 Construction of Switched Reluctance Motor	8
Figure 2.3 Working of SRM	9
Figure 2.4 PN Junction Diode.....	16
Figure 2.5 Polarized Capacitor	17
Figure 2.6 Inductor	18
Figure 3.1 Flowchart of overall circuit diagram	19
Figure 3.2 Control block diagram of SRM	25
Figure 3.3 Circuit Diagram of Switched Reluctance Motor	26
Figure 3.4 Source Battery Pack	26
Figure 3.5 Regeneration Battery Pack	27
Figure 3.6 Four Phase Convertor	27
Figure 3.7 MATLAB Function Block for SOC	28
Figure 3.8 MATLAB Function Block for Temperature	28
Figure 4.1 Graph between SOC, cell temperature VS time of Source battery pack.....	30
Figure 4.1 Graph between SOC, cell temperature VS time of Reg battery pack	31

CHAPTER ONE

INTRODUCTION

1.1 Background

The evolution of electric motors traces back to the 1800s when the DC motor was first introduced. Nikola Tesla played a significant role in advancing the field by advocating for AC over DC and promoting the induction motor. In the 1980s, a breakthrough occurred with the application of electronics to motors, enabling variable speed and torque control. Another notable development was the emergence of the Switched Reluctance Motor (SRM) in 1990, which revolutionized motor design by eliminating the need for windings in rotors. This marked a significant shift in motor technology after nearly 80 years and was made possible by cost reductions in power electronics, as SRMs require electronic components and software for effective operation.

In the 1960s, electric vehicles began to emerge, initially utilizing brushed motors, particularly series motors. However, it became evident that electric vehicles faced challenges in terms of their viability on the road. Prominent examples such as the EV-1 and Tesla's Roadster, both employing AC induction motors, highlighted the potential of electric vehicle technology. The optimization of hybrid systems, demonstrated notably by the Prius with its Interior Permanent Magnet (IPM) motor, showcased the fuel efficiency achievable in these vehicles. Notably, Tesla has also transitioned to using IPM motors in their recent models.

Looking ahead, Switched Reluctance Motors are expected to gain widespread adoption in electric vehicles due to their rapid technological advancements. This relatively new motor technology has been the subject of significant investment, and it is poised to outperform IPM motors in vehicle applications. Furthermore, SRMs offer the advantage of not requiring rare earth materials, unlike IPMs.

The power supply requirements of modern electric vehicles present challenges for traditional power converters. Additional circuitry is necessary to accommodate the charging of battery packs, resulting in increased system complexity. To address this, integrated battery packs and AHB converters are being developed to facilitate flexible energy conversion between generators, battery packs, and motors. These converters can configure multiple levels of bus voltage and current capacity, enabling efficient excitation and demagnetization during commutation.

Different driving and charging modes have been incorporated, although typically, an extra converter is necessary for the charging process. While driving, the SRM drive receives power from a booster, ensuring a stable DC connection voltage. The energy stored in the winding is replenished to the battery during each continuation and demagnetization period.

Innovative approaches have emerged, including a modular power-converter designed for four phase SRMs. This solution utilizes overlapping current pulses to boost motor speed while minimizing the number of power switch modules required. Moreover, the integration of the MBM topology enables adaptable operations in electric vehicles. By effectively controlling power switches, this system offers seven power supply mode, leveraging combination of PV panel and battery pack to enhance system flexibility. Furthermore, charging current also can be finely regulated, resulting in extended battery life through the implementation of three static charging methods for the batteries.

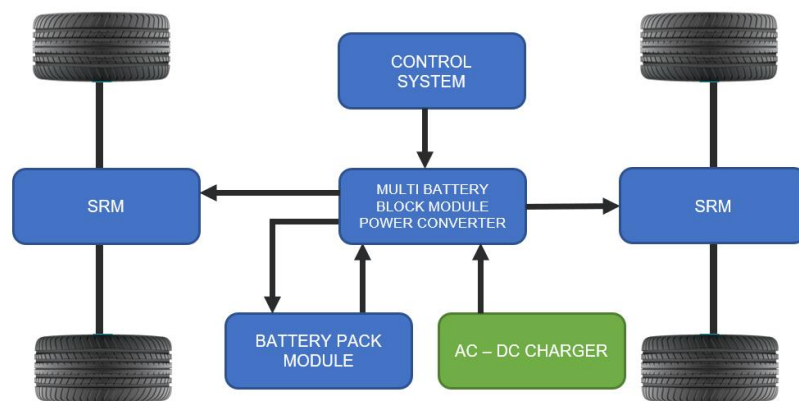

Figure 1.1 The electric vehicle drive system [1]

1.2 Problem Statement

The rise of electric vehicles is undeniable, driven by their environmental benefits and aesthetic appeal. As science and technology progress, new challenges arise, particularly in addressing the increasing energy demand while fossil fuel reserves dwindle. In the transportation sector, electric vehicles offer a promising solution to alleviate the energy crisis by reducing reliance on traditional fuels and presenting low operating costs and emissions.

Electric vehicles represent a relatively recent development in the automotive industry. Many global companies have embraced electric models as their core offerings, while some provide

hybrid options that combine both electricity and gasoline. Nissan, Ford, Tesla Model S, and Chevrolet Volt are among the manufacturers contributing to a greener and more sustainable environment through electric vehicle adoption.

While the demand for electric vehicles continues to grow due to their eco-friendliness and the rising cost of gasoline, there are still limitations that deter some individuals from fully embracing them. Factors such as limited mileage make electric vehicles less preferred for long-distance drives.

In response to this concern, our efforts have been dedicated to the development of a MBM along with the integration of PV panels into AHB converter. MBM topology facilitates the provision of multilevel bus voltage in order for the operation of Switched Reluctance Motors (SRMs). By effective control of power device inside proposed MBM, a variety of charging alternatives and power supply mode can too be implemented to accommodate diverse operational requirements.

1.3 Objective

Main Objective:

- To combine multiple battery pack, improve endurance, flexibility of charging and efficient control of Switched Reluctance Motor.

Specific Objective

- To design a multi-battery block module.
- To design Hysteresis – Control SRM Drive.
- Govern the motor speed using closed – loop proportional integral (PI) controller
- To improve the system flexibility by applying seven power supply modes.

1.4 Scope of the Project

The main goal of this project is to develop an innovative power converter known as the "multi-battery block module power converter." This converter is designed to effectively charge and discharge battery packs with different capacities. Its unique feature allows for the flexible combination of multiple battery packs, enabling efficient operation under the complex conditions encountered in electric vehicles. By controlling power switches, the integration of two battery packs and PV panels enables the realization of seven power supply

modes, thereby enhancing system flexibility. Additionally, the proposed model supports three battery static charging methods and enables flexible adjustment of the charging current, resulting in improved battery lifespan. Moreover, by incorporating an external battery, this solution aims to enhance power utilization efficiency and extend the endurance of battery packs.

1.5 Project Layout

This project consists of five chapters including the current chapter. This chapter – Introduction includes the theoretical background, problem statement, objectives, and scope of this project. Chapter two provides a literature review on theoretical articles or publications from conferences or transactions as well as books from major publishers. Chapter three includes the proposed layout of the project and the methods and tools that were implemented to attain the objectives of the project. Chapter four presents the results that have been obtained during the implementation of this project. Also, the discussion on the obtained results is performed. Chapter five gives conclusions about this project.

CHAPTER TWO

LITERATURE REVIEW

2.1 Review of Related Research Articles

With the increasing concerns surrounding the fossil fuel crisis and environmental issues, there has been a growing focus on electric vehicles (EVs) and hybrid electric vehicles (HEVs) due to their ability to reduce fuel consumption and enhance energy efficiency [1]-[4]. The SRM is a novel motor design characterized by convex pole structures for both rotor and stator. Unlike conventional motors, switched reluctance motors (SRMs) differ in their construction. SRMs eliminate the need for rotor windings and, instead, utilize a centralized winding in the stator. As a rare-earth-free motor, SRMs have gained attention as a promising alternative due to their simple structure, cost-effectiveness, robustness, reliability, and suitability for harsh environments [5]-[8].

The power converter utilized in switched reluctance motors (SRMs) holds a critical role in the speed control system and has a direct impact on the overall performance of the system [9]-[11]. However, conventional power converters fall short in meeting the intricate supply of power demands of electric vehicle, necessitating supplementary circuit for battery pack charging. This, in turn, leads to increased complexity within the system [12], [13]. In the case of electric vehicles, the multi-battery pack module typically comprises multiple individual batteries and backup batteries. The selection of an appropriate number of batteries to participate in power supply is crucial, taking into account operational requirements, remaining capacity and operating condition of battery.

To address the challenges associated with power converters for switched reluctance motors (SRMs), several approaches have been suggested. For instance, a particular integrated power converter design [14] combines the Buck converter and the asymmetrical half-bridge (AHB) converter in series, resulting in an accelerated process for demagnetization. As, this design is primarily appropriate for low-current buck charging modes. Another proposal [15] introduces a dual front end circuit that utilizes a photovoltaic panel feed, eliminating the need for external charging stations. This design supports 5 charging mode & 6 driving mode but requires added converter to charge. In reference [16], integrated battery-driven converter to be used for SRMs is presented, enabling onboard battery charging. SRM drive is energized through booster during driving condition, establishing a properly managed DC connection

voltage. Finally, [17] proposes 4 -phase hysteresis-control switched reluctance motor driver, employing hysteresis control in case of operation in low speed for electric vehicle.

To address the limitations of intricate power converter configurations, various modular power converters have been recommended [18]–[20]. For instance, in reference [20], a modular power converter is proposed for a four-phase switched reluctance motor (SRM). This converter capitalizes on overlapping current pulses, boosting motor speed while minimizing the need for multiple power switch modules. Also modular power converter enhances performance of motor across entire range of characteristics of motor. MBM topology is introduced to enable a easy integration of multi batteries, thus accommodating intricate operational requirements of electric vehicle.

2.2 Switched Reluctance Motor

The operation of the Switched Reluctance Motor (SRM) is based on the principle of variable reluctance, employing a switching circuit to produce rotating magnetic field. Here main concept revolves around adjusting the magnetic circuit reluctance, which is determined by air gap between the rotor and stator. By controlling this air gap, the motor's reluctance can be modified. Reluctance refers to the resistance to magnetic flux and can be compared to electrical resistance in circuits. Figure 2.1 illustrates the block diagram of an SRM, with the driver/converter circuit connected to the DC input and the motor connected to output. The feedback from wire of rotor sensor is linked to controller circuit, providing rotor position information relative to the reference axis. The controller integrates the collected data and generates a reference signal for the stator. Moreover, it constantly monitors the motor current to ensure protection against internal and external faults.

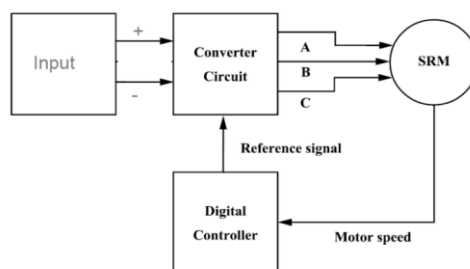

Figure 2.1 Block Diagram of SRM [2]

Working Principle

Consider an iron piece that is placed in a magnetic field; it will get align itself within the position of minimum value of reluctance and become magnetically lock. This same principle applies to the switched reluctance motor, where the rotor attempts to align its minimum reluctance portion with stator magnetic field, resulting in development of rotor reluctance torque .

To enhance clarity, let's adopt following notations for our motor:

Stator Pole:

AA' pole axis for phase A

BB' pole axis for phase B

CC' pole axis for phase C

Rotor Pole:

aa' rotor pole axis for Position 1

bb' rotor pole axis for Position 2

At beginning, input is supplied to the A-phase, while the C and B phases do not have their maximum or minimum values. This arrangement causes the alignment of the stator-pole axis AA' with the rotor-pole axis aa'.

According to figure 2.3, it can be observed that phase A has reached in the position of minimum value of reluctance. This is attributed to the narrow air gap between the stator and rotor, which brings them into close proximity and results in the minimum reluctance compared to the other poles. In this particular state, the torque generated is equal to zero ($\text{Torque} = dL_a/d\theta = 0$), where L_a represents the phase inductance and θ represents the angle of rotation.

Following that, the A-phase is deactivated, and B phase is activated. Rotor-axis bb' undergoes rotation in a clockwise direction to align with the stator axis BB'. Reversing the motor's rotation becomes effortless by altering the motor's polarity. Torque is generated as reluctance goes change from maximum value to minimum value and is calculated using formula $\text{Torque} = 1/2 i^2 B (dlb/d\theta)$.

The movement of the rotor depends on number of pole, and here for us, one phase is energized at a time, resulting in a rotation of 30 degrees. At the position labeled as BB', no torque is present ($\text{Torque} = dlb/d\theta = 0$). Subsequently, the B-phase is deactivated, and the C-phase is activated. As the rotor-axis aa' aligns with the stator-axis CC', torque is generated, causing the rotor to continue rotating for another 30 degrees.

The sequence continues as phase A is restarted after phase C is turned off. The motor operates in this manner as long as there is a supply of input power. It is evident that the motor is capable of self-starting, as it initiates rotation on its own. Control circuit monitors continuously both the input current and motor speed. In case motor speed goes below specified reference value, control system adjusts the input current to meet the required speed. In the event that the motor current exceeds the full load current, the control system initiates appropriate measures.

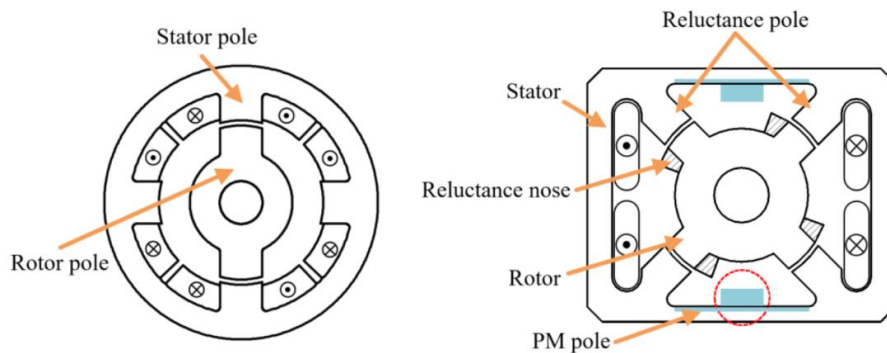

Figure 2.2 Construction of Switched Reluctance Motor [2]

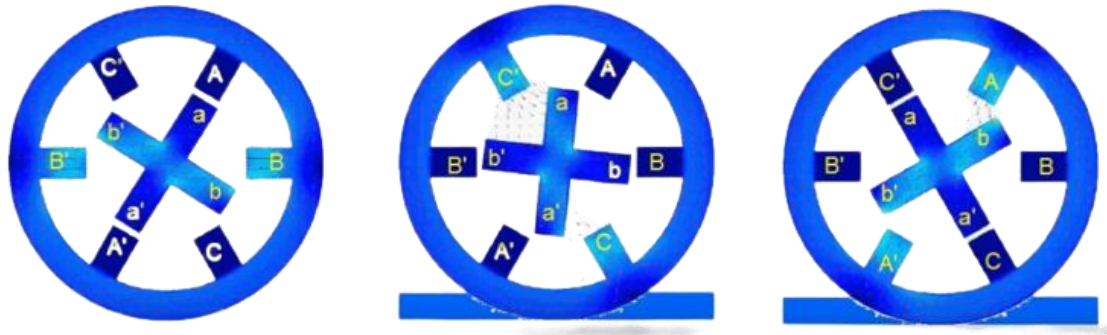

Figure 2.3 Working of SRM

2.3 MATLAB

MATLAB (short for Matrix Laboratory) is a programming language as well as numerical computing software developed by MathWorks. It is used widely in various fields such as engineering, science, finance, and economics for data analysis, visualization, and algorithm development. In this essay, we will discuss the history of MATLAB, its features and capabilities, and some examples of its applications.

History

MATLAB was first developed by Cleve Moler, a computer science at the University of New Mexico, in the 1970s. Moler wanted to create a tool that would allow him and his colleagues to easily solve numerical problems in their research. He wrote the first version of MATLAB in Fortran and later rewrote it in C. The first commercial version of MATLAB was released in 1984.

Over the years, MATLAB has evolved and expanded its capabilities. In 1992, MathWorks introduced the MATLAB Compiler, which allowed users to compile their MATLAB code into standalone applications. In 1997, the MATLAB Neural Network Toolbox was introduced, which provided tools for designing and simulating neural networks. Since then, MathWorks has continued to develop and add new toolboxes to MATLAB.

Features and Capabilities

MATLAB is a powerful tool for numerical computation, data analysis, and algorithm development. Some of its key features and capabilities include:

- ❖ **Matrix Manipulation:** MATLAB is designed to work with matrices, which makes it a powerful tool for mathematical and numerical computations. It supports a variety of matrix operations such as addition, subtraction, multiplication, division, and inversion.
- ❖ **Programming Language:** MATLAB has its own programming language that is easy to learn and use. It supports a variety of programming constructs such as loops, conditionals, functions, and data structures.
- ❖ **Interactive Environment:** MATLAB provides an interactive environment for executing commands and scripts, which makes it easy to explore and analyze data. The MATLAB Command Window allows users to enter commands and execute them immediately, while the MATLAB Editor provides a more powerful editing environment for creating and editing scripts and functions.
- ❖ **Graphics and Visualization:** MATLAB has a variety of built-in functions for creating high-quality graphics and visualizations, which makes it useful for presenting and communicating data. It supports 2D and 3D plots, histograms, scatter plots, and other visualization techniques.
- ❖ **Toolboxes:** MATLAB comes with a wide range of toolboxes that provide additional functions and capabilities for specific applications, such as signal processing, control systems, and image processing. These toolboxes provide a way for users to extend MATLAB's capabilities and tailor it to their specific needs.
- ❖ **Integration:** MATLAB can be integrated with other programming languages and software tools, making it a versatile and flexible platform for data analysis and algorithm development. It supports integration with C/C++, Java, Python, and other programming languages, as well as integration with other software tools such as Excel, LabVIEW, and Simulink.

Applications

MATLAB is used widely in various fields such as engineering, science, economics and finance. Some examples of its applications include:

- ❖ **Signal Processing:** MATLAB is commonly used for processing signals in various applications such as audio and video processing, telecommunications, and control systems. The Signal Processing Toolbox provides a variety of functions for filtering, transforming, and analyzing signals.
- ❖ **Control Systems:** MATLAB is commonly used for designing and analyzing control systems, such as those used in aerospace, automotive, and manufacturing applications. The Control System Toolbox provides a variety of functions for simulating, modeling and analyzing of control systems.
- ❖ **Image Processing:** MATLAB is used commonly for processing and analyzing images in various applications such as medical imaging, computer vision and remote sensing. The Image Processing Toolbox provides a variety of functions

2.4 Simulink

Simulink was first introduced by MathWorks in 1984 as a tool for modeling and simulating control systems. It was based on the block diagram approach used in control system design, which made it easy for engineers to model and simulate complex systems. Over the years, Simulink has evolved and expanded its capabilities, and today it is widely used for modeling as well as simulating a wide range of dynamic systems.

Features and Capabilities

Simulink is a powerful tool for modeling as well as simulating dynamic systems. Some of its key features and capabilities include:

- ❖ **Block Diagram Approach:** Simulink uses a block diagram approach to modeling, which makes it easy to represent complex systems using a graphical interface. The user can drag and drop blocks from a library and connect them together to create a system model. Each block represents a mathematical operation or function that is used to describe the behavior of the system.

- ❖ Customizable Block Libraries: Simulink comes with a wide range of built-in block libraries, including blocks for linear and nonlinear systems, control systems, signal processing, and more. Users can also create their own custom block libraries and share them with others.
- ❖ Simulation and Analysis: Simulink provides tools for simulating and analyzing dynamic systems. The user can run simulations to see how the system behaves under different conditions, and use analysis tools to analyze the results. Simulink supports a variety of simulation methods, including fixed-step, variable-step, and hybrid simulation.
- ❖ Code Generation: Simulink can generate code for embedded systems, which makes it useful for designing and testing control systems and other embedded applications. The generated code can be deployed on a variety of platforms, including microcontrollers, FPGAs, and DSPs.
- ❖ Integration with MATLAB: Simulink is integrated with MATLAB, which makes it easy to use MATLAB functions and scripts in Simulink models. Simulink also supports integration with other software tools, such as Excel and LabVIEW.

Applications

Simulink is used widely in various fields such as engineering, science, and economics. Some examples of its applications include:

- ❖ Control Systems: Simulink is commonly used for modeling and simulating control systems, such as those used in aerospace, automotive, and manufacturing applications. The user can create a model of the control system using Simulink blocks, and then simulate the system to see how it behaves under different conditions.
- ❖ Signal Processing: Simulink is commonly used for signal processing applications, such as audio and video processing, telecommunications, and image processing. The Signal Processing Toolbox provides a variety of blocks and functions for filtering, transforming, and analyzing signals.
- ❖ Power Systems: Simulink is commonly used for modeling and simulating power systems, such as those used in electrical power generation and distribution. The Power Systems Toolbox provides a variety of blocks and functions for modeling power systems and analyzing their behavior.

- ❖ **Robotics:** Simulink is commonly used for modeling and simulating robots, such as those used in manufacturing and industrial applications. The Robotics Toolbox provides a variety of blocks and functions for modeling robot kinematics, dynamics, and control.
- ❖ **Financial Modeling:** Simulink is commonly used for financial modeling and analysis, such as modeling stock prices and options. The Financial Toolbox provides a variety of blocks and functions for modeling financial systems and analyzing their behavior.

2.5 Battery

Over the years, batteries have evolved and expanded their capabilities, and today they are widely used in various applications. The development of rechargeable batteries has also made them more sustainable and cost-effective.

Components of a Battery

A battery consists of several components, including:

- ❖ **Electrodes:** An electrode is a material that can conduct electricity and participates in the electrochemical reaction that generates the electrical energy in the battery.
- ❖ **Electrolyte:** An electrolyte is a material that conducts ions between the electrodes, allowing the electrochemical reaction to occur. The electrolyte can be a liquid, gel, or solid material.
- ❖ **Separator:** A separator is a material that separates the anode and cathode and prevents them from touching each other, while allowing the passage of ions between them.
- ❖ **Terminal:** A terminal is a connection point on the battery that allows the electrical energy to be transferred to an external circuit.

Types of Batteries

There are different types of batteries, including:

- ❖ **Primary Batteries:** Primary batteries are not rechargeable and are designed to be used once and then disposed of. They are commonly used in applications such as flashlights, smoke detectors, and remote controls.
- ❖ **Secondary Batteries:** Secondary batteries are rechargeable so that can be used multiple times by recharging them. They are commonly used in electric vehicles, smartphones, and laptops.

- ❖ **Lead-Acid Batteries:** Lead acidic batteries are a type of secondary battery that use lead plates and an electrolyte of sulfuric acid. They are commonly used in automotive and industrial applications.
- ❖ **Nickel-Cadmium (NiCd) Batteries:** Nickel-cadmium batteries are a type of secondary battery that use nickel oxide and cadmium plates and an alkaline electrolyte.
- ❖ **Lithium-Ion (Li-ion) Batteries:** Li-ion batteries are a type of secondary battery that use lithium cobalt oxide, lithium iron phosphate, or other materials as electrodes and a liquid or gel electrolyte. They are commonly used in applications such as smartphones, laptops, and electric vehicles.

Applications

Batteries are used widely in various applications, which are :

- ❖ **Portable Devices of Electronic:** Batteries are commonly used in portable devices of electronic, such as smartphones, laptops, and tablets. The development of lithium-ion batteries has made it possible to make these devices smaller and more portable.
- ❖ **Electric Vehicles:** Batteries are a key component of electric vehicles, providing the energy storage needed to power the vehicle. The development of large-capacity lithium-ion batteries has made EV more practical and affordable.
- ❖ **Storage of Energy :** Batteries are commonly used in energy storage systems, such as those used in solar and wind power systems.

2.6 IGBT

IGBT stands for Insulated Gate Bipolar Transistor, which is a type of semiconductor device used for power control and switching applications.

IGBT combines the advantages of both MOSFET and Bipolar Junction Transistor (BJT) to offer high voltage and current capacity along with fast switching speed. It is used widely in a variety of applications including motor control, power supplies, renewable energy systems, and industrial automation.

The structure of an IGBT consists of a P-type semiconductor layer (anode), an N-type semiconductor layer (cathode), and a gate terminal. The gate terminal is separated from the semiconductor layers by a thin layer of insulating material. When a voltage is applied to the gate

terminal, it creates an electric field that allows or blocks the flow of current between the anode and cathode terminals.

IGBTs have many advantages over other power semiconductor devices, including high voltage capability, low on-state voltage drop, high current carrying capacity, and fast switching speed. They can also operate at high temperatures and are more reliable than other types of power devices.

Overall, IGBTs are an important component in many power electronics applications, allowing for efficient and effective control of high-power electrical systems.

2.7 Diode

A diode is a semiconductor device that permits current to flow in a single direction. It comprises two regions: an N-type semiconductor region and a P-type semiconductor region, which are interconnected to create a junction. The P-type region contains an excess of positive charge carriers (known as holes), while the N-type region contains an excess of negative charge carriers (electrons).

When a voltage is applied across the diode, the majority carriers (electrons in the N-type region and holes in the P-type region) migrate towards the junction. In the forward direction (positive voltage on the P-type region and negative voltage on the N-type region), the majority carriers move towards the junction and recombine. This enables the easy flow of current through the diode. However, in the reverse direction (positive voltage on the N-type region and negative voltage on the P-type region), the majority carriers are repelled from the junction and cannot pass through the diode. As a result, the diode acts as an insulator and prevents current from flowing.

The behavior of a diode lends itself to various electronic applications, including rectification, voltage regulation, and signal detection. In rectification, diodes are employed to convert AC power into DC power by allowing current to flow in one direction only. For voltage regulation, diodes maintain a constant voltage by inhibiting current flow in one direction when the voltage surpasses a specific threshold. In signal detection, diodes are used to detect and demodulate radio signals.

In summary, diodes are essential components in modern electronics and find applications across a wide range of fields.

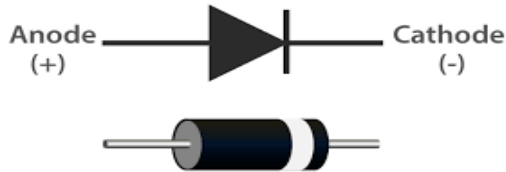

Figure 2.4 PN Junction Diode

2.8 Capacitor

A capacitor is an electronic component which stores the energy of electricity in an electric field. It consists of two metal plates, or conductive layers, separated by an insulating material called the dielectric. The conductive plates are connected to a voltage source, which charges the capacitor by transferring electrons from one plate to the other. When the voltage source is removed, the charged capacitor can store the electrical energy.

Capacitors have many important applications in electronics, including smoothing power supplies, filtering out noise, and storing energy for use in circuits. They can also be used in timing circuits, oscillators, and signal coupling.

The capacitance of a capacitor is a measure of its ability to store electrical energy. It is determined by the area and separation distance of the conductive plates and the dielectric material. Capacitance is measured in farads (F), although most capacitors used in electronics have capacitances much smaller than a farad. Instead, capacitors are often measured in microfarads (μF) or picofarads (pF).

Capacitors can be categorized into two main types: polarized and non-polarized. Polarized capacitors have a positive and negative terminal and must be connected in the correct polarity, while non-polarized capacitors can be connected in either direction.

Overall, capacitors are a crucial component in electronics, allowing for the storage and manipulation of electrical energy in a wide range of applications.



Figure 2.5 Polarized Capacitor

2.9 Inductor

An inductor is an electronic component that retains energy within a magnetic field. Comprising a wire coil, often wound around a magnetic core, it exhibits resistance to changes in current by inducing a voltage proportional to the rate of current change. The inductor's energy storage capability in its magnetic field depends on factors such as the coil's number of turns, cross-sectional area, and the core material utilized.

Inductors hold significant importance in various electronics applications, serving purposes such as energy storage, filtering, and impedance matching. They find utilization in timing circuits, transformers, and oscillators as well.

Inductance serves as a measure of an inductor's ability to store energy in its magnetic field. It relies on parameters like the number of coil turns and the physical dimensions of the coil and core material. Inductance is commonly measured in henries (H), although electronic inductors typically possess inductance values much smaller than a henry. Therefore, millihenries (mH) or microhenries (μH) are commonly used units to express inductance.

Inductors can be categorized into two main types: air-core and iron-core. Air-core inductors feature non-magnetic cores made of materials like plastic or ceramic. They are well-suited for high-frequency applications due to their low resistance and high Q factor. In contrast, iron-core inductors employ magnetic core materials such as iron or ferrite. These inductors are preferred for low-frequency applications as they offer high inductance and the ability to store larger amounts of energy.

To sum up, inductors play a critical role in electronics, enabling the storage and manipulation of energy across a diverse range of applications.



Figure 2.6 Inductor

CHAPTER THREE METHODOLOGY

3.1 Flowchart

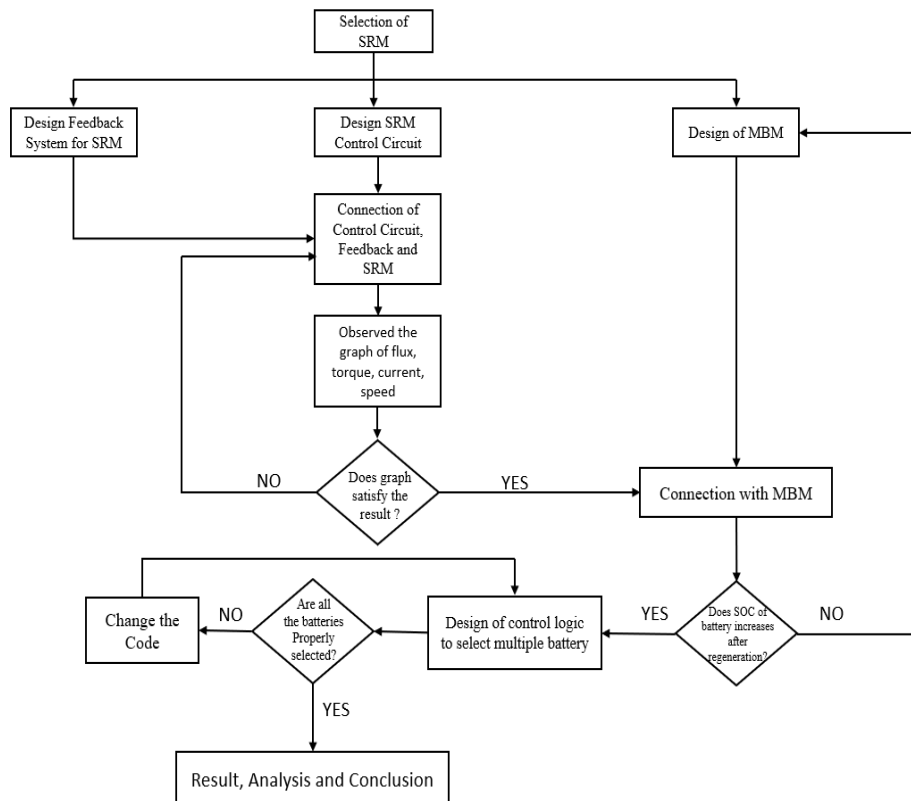

Figure 3.1 Flowchart of overall circuit diagram

3.2 Selection of SRM

The selection of a Switched Reluctance Motor (SRM) requires consideration of various factors, including the desired power output, torque requirements, speed range, and control system requirements. Here is a general procedure for selecting an SRM:

- ❖ Determine the power requirements: Calculate the required power output of the SRM based on the application. This can be determined by considering factors such as the load torque, operating speed, and duty cycle.
- ❖ Determine the torque requirements: Calculate the required torque output of the SRM based on the application. This can be determined by considering factors such as the load torque, acceleration, and deceleration requirements.
- ❖ Determine the speed range: Determine the desired speed range of the SRM based on the application. This can be determined by considering factors such as the maximum and minimum operating speeds, and the required speed response.
- ❖ Determine the control system requirements: Determine the required control system for the SRM based on the application. This can be determined by considering factors such as the required accuracy, response time, and complexity.
- ❖ Compare and select the appropriate SRM: Based on the above factors, compare the performance characteristics of different SRMs available in the market. Consider factors such as the rated power, torque, speed range, control system compatibility, and cost.
- ❖ Verify the motor specifications: Once a suitable SRM has been selected, verify the motor specifications to ensure that it meets the application requirements. This includes verifying the motor size, operating temperature range, and mounting dimensions.
- ❖ Determine the drive system requirements: Finally, determine the drive system requirements for the SRM, which includes the power electronics, control algorithms, and feedback sensors required to drive and control the motor.

Overall, the selection of an SRM requires careful consideration of the application requirements, as well as the performance characteristics of different SRMs available in the market. A thorough analysis of these factors can help to ensure the selection of an SRM that meets the performance and cost requirements of the application.

We do have different type of SRM based on number of stator and rotor poles. We had selected 4 phase, 75KW Switched Reluctance Motor.

3.3 Control Circuit

A control circuit for a Switched Reluctance Motor (SRM) is an essential component for driving and controlling the motor. The control circuit typically includes power electronics, control algorithms, and feedback sensors to regulate the current flow and timing of the motor phases, thereby controlling the motor torque and speed. Here is a brief overview of the components of a control circuit for an SRM:

- ❖ **Power Electronics:** The power electronics convert the input power supply (DC or AC) to a high-frequency voltage and current that is used to drive the motor. The power electronics typically consist of a rectifier, DC-DC converter, and inverter. The inverter is responsible for generating the high-frequency voltage and current required for the motor.
- ❖ **Control Algorithms:** The control algorithms are used to regulate the timing and duration of the current flow in the motor phases. The algorithms typically use a combination of pulse width modulation (PWM), current sensing, and feedback control to regulate the motor torque and speed.
- ❖ **Feedback Sensors:** The feedback sensors are used to monitor the motor performance and provide feedback to the control algorithms. The most common feedback sensors used in SRM control circuits are position sensors, which are used to determine the rotor position and enable accurate timing control of the motor phases.

The control circuit for an SRM is typically designed to operate in one of two modes: open-loop or closed-loop. In open-loop mode, the control circuit uses pre-determined current waveforms and timing to regulate the motor performance, without any feedback control. In closed-loop mode, the control circuit uses feedback sensors to monitor the motor performance and adjust the current waveforms and timing to maintain the desired motor performance.

Overall, the design of a control circuit for an SRM requires careful consideration of the motor specifications and the application requirements, as well as the performance and cost trade-offs of different components and control strategies. A well-designed control circuit can help to maximize the efficiency and performance of an SRM, while minimizing the cost and complexity of the control system.

Control circuit was modeled using 8 IGBT and 8 Diode.

3.4 Multiple Battery Module

A multiple battery module refers to a configuration where two or more batteries are interconnected either in series or parallel to enhance the overall capacity or voltage of the battery system. Each individual battery within the module, known as a cell, is meticulously selected to meet specific power and energy requirements.

The utilization of multiple battery modules has become increasingly prevalent across various domains, including electric vehicles, renewable energy systems, and uninterruptible power supplies (UPS). These configurations offer several advantages, such as augmented energy storage capacity, heightened reliability, and the capability to accommodate higher power demands.

In a series configuration, the positive terminal of one battery is linked to the negative terminal of the subsequent battery, resulting in an amplified voltage output. For instance, if two 12-volt batteries are connected in series, the overall voltage output would reach 24 volts. Series configurations are frequently employed in electric vehicles and renewable energy systems to furnish elevated voltage outputs.

On the other hand, in a parallel configuration, the positive terminals of each battery are interconnected with the positive terminals of the other batteries, while the same is done for the negative terminals. This arrangement leads to an increased capacity. For instance, if two 12-volt batteries are connected in parallel, the overall capacity would be twice that of a single battery, while the voltage output would remain at 12 volts. Parallel configurations are commonly employed in UPS systems and other applications requiring substantial energy storage capacity.

It is vital to emphasize the significance of proper balancing when employing multiple battery modules to ensure uniform charging and discharging among each cell. This balance is critical for extending the battery life. Battery management systems (BMS) are often employed to monitor the health and performance of multiple battery modules. These systems facilitate proper

charging and discharging, prevent overcharging or over-discharging, and contribute to optimal performance.

In summary, multiple battery modules offer a versatile and efficient approach to enhance the capacity and voltage of battery systems. They enable greater flexibility and performance in a wide array of applications. Three batteries each with 240 V, 1 Ah with SOC 70%, 60%, 50% respectively was used.

3.5 Breaker

In Simulink, the Breaker block can also be used as a switch to enable or disable a portion of a model based on a specified condition. This can be useful for implementing control logic or for simulating different scenarios.

To use the Breaker block as a switch, we can follow these steps:

- ❖ Open our Simulink model.
- ❖ Navigate to the Simulink library browser, and search for the Breaker block.
- ❖ Drag the Breaker block from the library browser onto our Simulink model.
- ❖ Double-click the block of Breaker to open the Block Parameters dialog box.
- ❖ In the dialog box of Block Parameters dialog, specify the condition that will enable or disable the Breaker block. This condition can be specified as a Simulink expression or a MATLAB expression.
- ❖ Save the changes and run the simulation.

When the condition specified in the Breaker block is true, the block behaves as an open circuit and prevents the flow of data or signals through it. When the condition is false, the block behaves as a closed circuit and allows data or signals to flow through it.

We can use the Breaker block as a switch to enable or disable a group of blocks or subsystems in your model based on a specified condition. This can be useful for implementing control logic

or for simulating different scenarios. By using the Breaker block as a switch, we can easily modify the behavior of our Simulink model without having to delete or add blocks.

3 terminal breaker were used where it connects the battery with SRM when control signal is provided from MATLAB function block.

3.6 MATLAB function Block

A MATLAB function block is a block in Simulink, which is a graphical programming environment for modeling, simulating, and analyzing dynamic systems. The MATLAB function block allows us to incorporate custom MATLAB code into a Simulink model.

With the MATLAB function block, we can write MATLAB code to implement mathematical operations, algorithms, and other custom functions that are not available in the standard Simulink blocks. The MATLAB function block can accept input signals from other blocks in the Simulink model and produce output signals that can be used by other blocks.

To use the MATLAB function block, you first need to create a MATLAB function that defines the operation or algorithm we want to implement. we can then insert the MATLAB function block into our Simulink model and specify the name of the MATLAB function you want to use. We can also specify the input and output ports of the block, and set various block parameters such as sample time, data type, and optimization options.

The MATLAB function block allows us to create complex models and simulations that involve custom algorithms and functions. It can be particularly useful in applications such as signal processing, control systems, and machine learning, where custom mathematical operations and algorithms are often required.

Overall, the MATLAB function block is a powerful tool for incorporating custom MATLAB code into Simulink models, allowing for greater flexibility and functionality in dynamic system modeling and simulation.

Coding of multiple battery control logic was done inside the MATLAB function block.

3.7 Control Block Diagram of SRM

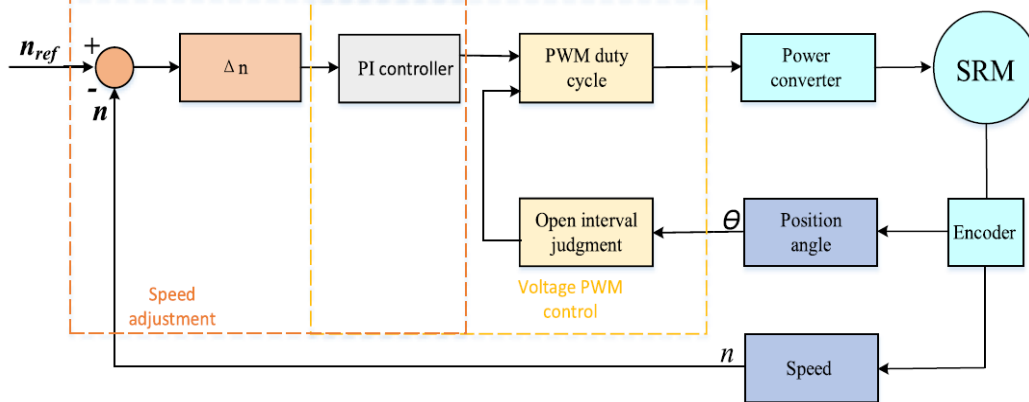

Figure 3.2 Control block diagram of SRM

The control strategy of the SRM system is illustrated in Figure 3.2, depicting a block diagram that incorporates a PWM control method. This control system offers remarkable precision, allowing for easy regulation of phase current and excitation voltage by adjusting the duty cycle of the PWM wave. The utilization of PWM control results in high control accuracy and favorable outcomes.

The control system generates the required switching signals by comparing a specified speed reference with the actual motor speed. The rotor position is found by using encoder, which enables the calculation of the motor's speed. Using this information, the appropriate angles for initiating and terminating phases are determined to facilitate the process of phase commutation. A proportional integral (PI) controller is used in order to achieve closed-loop control to finely regulate motor speed.

3.8 Circuit Diagram in SIMULINK

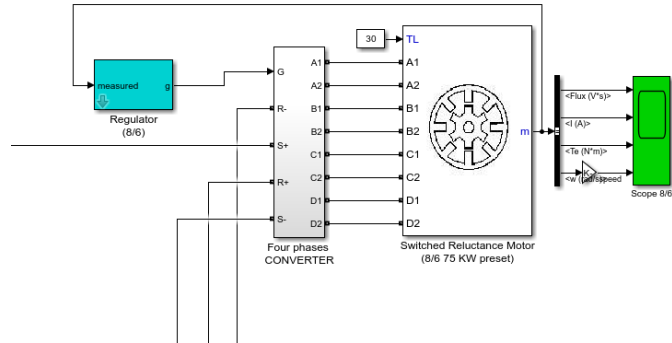

Figure 3.3 Circuit Diagram of Switched Reluctance Motor

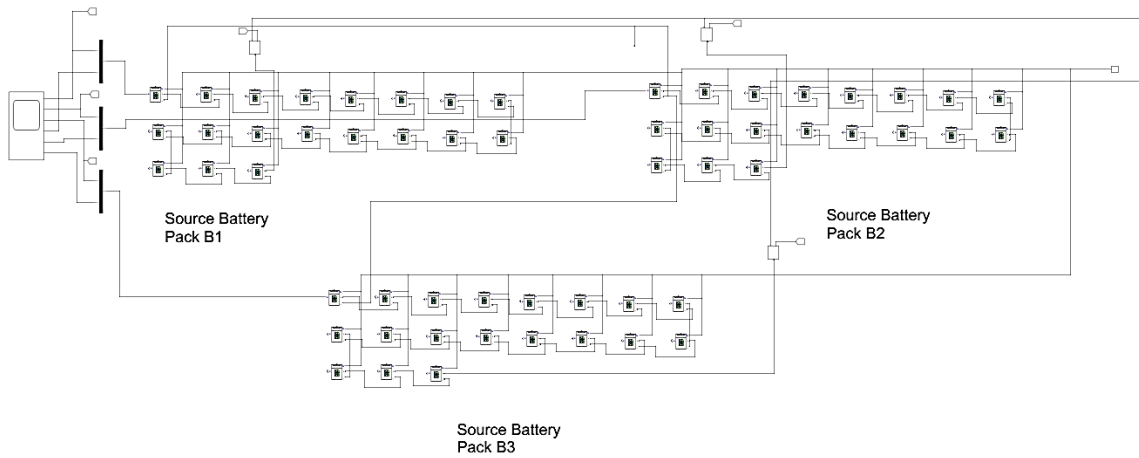

Figure 3.4 Source Battery Pack

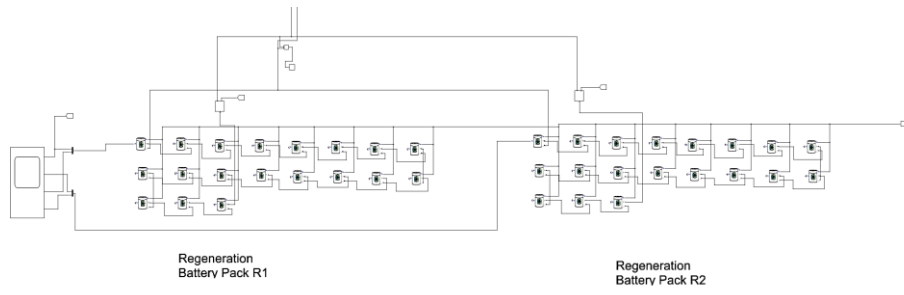

Figure 3.5 Regeneration Battery Pack

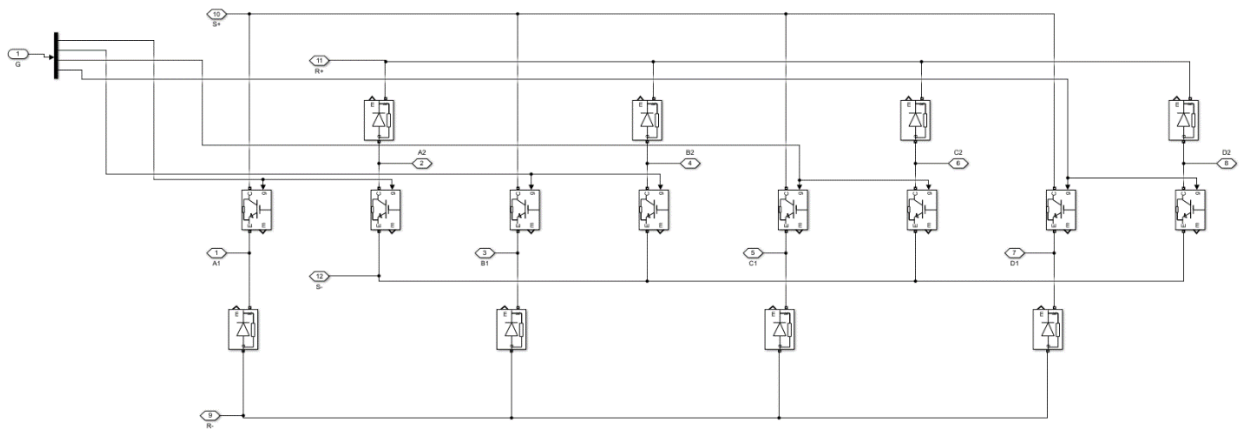

Figure 3.6 Four Phase Convertor

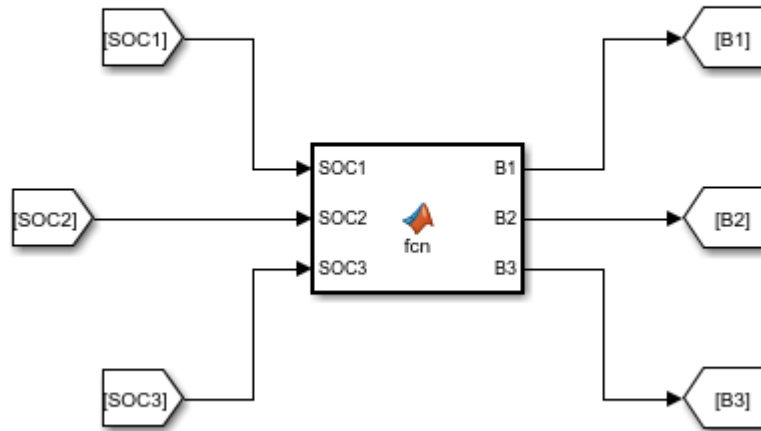

Figure 3.7 MATLAB Function Block for SOC

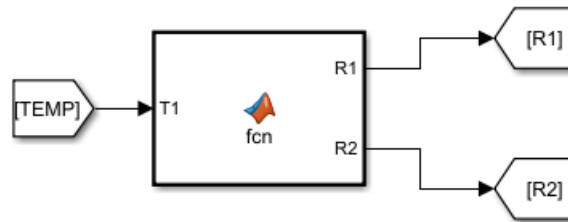

Figure 3.8 MATLAB Function Block for Temperature

We had used MATLAB and Simulink software to execute the simulation of our project. Fig 3.3 represents the circuit diagram of 75KW Switched Reluctance Motor having 8 stator poles and 6 rotor poles. The rotor pole in SRM is always less than the stator pole. The resistance of stator winding is kept at 0.05 ohm, inertia = 0.01 kg. m.m, initial speed and position= $[W_o \text{ (rad/sec)}, \theta_o \text{ (rad)}]$: [0,0]. The torque load (TL) is kept at 30. The regulator of fig 3.3 is use to generate gate signal from PI controller which is then fed into Four Phase Converter. In regulator we had kept reference current 200Amp, initial position of rotor [0,-15,-30,-45], turn on angle= 37.5 deg and turn off angle= 57.5 deg. Then, we designed 4 phase converter as shown in Fig 3.6 to operate SRM. It consists of two IGBTs and two diodes in each phase and total of 8 IGBT and

8 Diodes. Here, S+ and S- indicate +ve and -ve supply voltages respectively whereas R+ and R- indicate +ve and -ve regeneration voltages respectively. Since we are regenerating the same supply battery so we connected R+ and R- with S+ and S- respectively. Four gate signals are generated from the feedback regulator which triggered the 8 IGBTs with 2 in a pair of the same phase at the same time. In this way, when both IGBT get triggered, the motor gets power from the battery and when they are turned off, the battery gets charged from energy stored in a coil of SRM.

Fig 3.4 illustrates the three battery pack which is use to supply power to SRM one at a time through breaker. Fig 3.5 indicates the regenerative battery pack use to store regenerated energy from SRM. Now, we had combined three batteries in parallel to model MBM. Here, a breaker is used to control the flow of current from a specific battery only. The breaker operates when it gets a control signal from the MATLAB function block. The input in MATLAB function block is SOC1, SOC2, SOC3, and output is B1, B2, B3 which is shown in figure 3.7 where SOC1, SOC2, SOC3 represent the state of charge of battery B1, B2, B3 respectively. The fig 3.8 represents the MATLAB Function block which monitor the temperature of battery pack R1 and switches to another according to its thermal limit. Here ambient temperature is kept at 30 deg Celsius. Initially, SOC1 is kept at 70%, SOC2 = 70%, SOC3 = 70% respectively. R1 and R2 are the regenerative battery pack. The battery pack composed of 19 (LiFeMgPO4) batteries each with 12.8V nominal voltage rating, 40Ah current capacity.

CHAPTER FOUR RESULT AND DISCUSSION

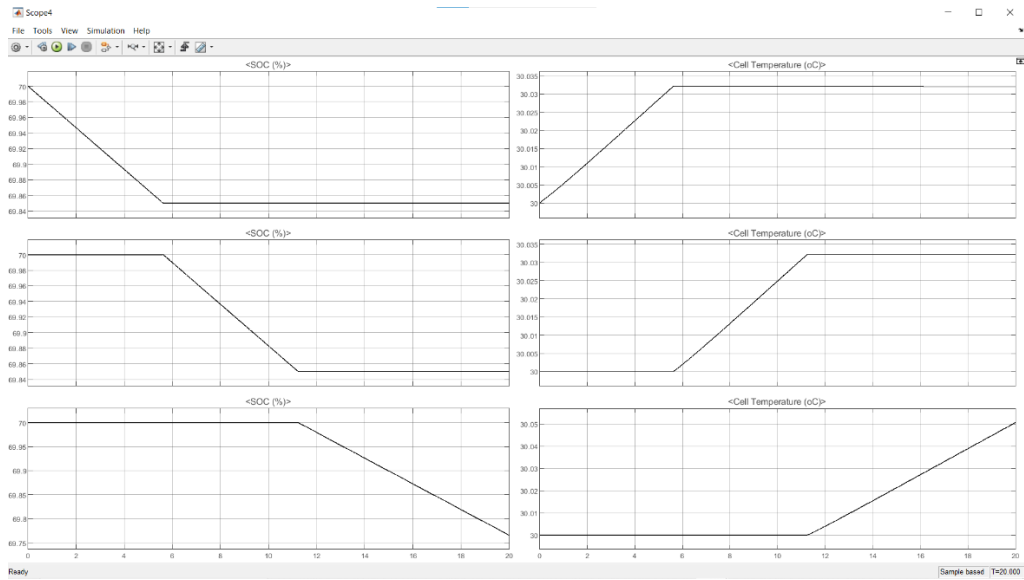

Figure 4.1 graph between SOC, cell temperature VS time of battery pack B1, B2, B3

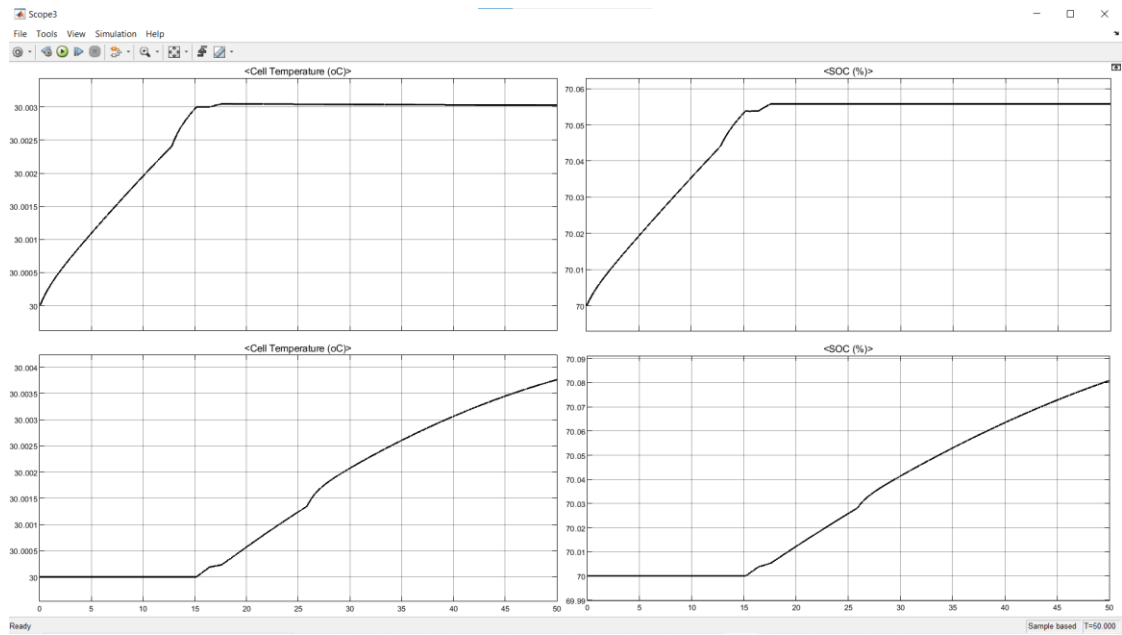

Figure 4.2 Graph between SOC, Cell Temperature VS time of Battery Pack R1 & R2

As shown in Figure 4.1, SRM gets powered from battery B1 due to which SOC start to decrease with an increase in time. When temperature of B1 exceeds 30.03 deg celcius (at around 5 seconds),the breaker connected to B1 gets turned OFF and the breaker connected to B2 turns ON and starts supplying the power to SRM. Since B1 no longer contributes to powering the system, terminal voltage of B1 increases whereas the terminal voltage of B2 decreases than previous value. Since Battery B2 is supplying power to SRM, its SOC starts to decrease from 70% and slowly reaches 69.8% as shown in Figure 4.1 (at around 11 seconds). As the temp of B2 reaches its thermal limit (30.03 deg celcius) breaker B2 cut off the supply and stops the power flow of B2 towards the SRM. At the same time breaker near B3 turned ON and now power flows from B3 towards SRM. The terminal voltage of B2 returns to its original value whereas the terminal voltage of B3 start to decrease. Since B3 is involved in power supply so its SOC starts to decrease from 70% and reaches to 69.8% at the end of 20 second of simulation time as shown in Figure 4.1.

Battery R1 and R2 is connected to the regenerative part of SRM. The SOC of battery R1 and R2 is 70% initially and after 20 seconds of simulation, SOC of R1 increases to 70.05% and R2 to 70.08% due to the regeneration of electrical energy from SRM. The switching of R1 and R2 is based on their thermal limit which was set to 30.003 deg for R1.



$$\text{Decrease in SOC from battery pack} = 0.15 + 0.15 + 0.22 = 0.52 \%$$

$$\text{Increase in SOC of Batter pack} = 0.135 \%$$

$$\% \text{ Regeneration} = \frac{\text{Increase in SOC from battery pack}}{\text{Decrease in SOC of Battery pack}} * 100\% = \frac{0.135}{0.52} * 100 = 26\%$$

We had successfully regenerated 26% of supplied energy from the regenerative mode of switched reluctance motor. Extra energy is utilized by motor for work done and some part of energy is lost due to losses like noise, vibration, leakage reactance.

CHAPTER FIVE

CONCLUSION AND RECOMMENDATION

5.1 Conclusion

This project proposes an innovative approach to control and regenerate energy from a switched reluctance motor (SRM) for electric vehicles using a multi-battery system. By adopting this configuration, the proposed system overcomes the limitations of a single battery pack and maximizes the potential of the SRM.

The control system implemented in this project utilizes a proportional-integral (PI) controller, which is carefully optimized to ensure efficient operation and minimize losses. The PI controller plays a crucial role in maintaining the desired performance of the SRM while achieving optimal energy regeneration. Through simulation on a 75 kW SRM, the results of this project exhibit significant enhancements in performance compared to traditional control methods. Notably, an impressive 26% of energy regeneration is achieved, which greatly contributes to the overall efficiency of the system.

To complement the multi-battery setup, a sophisticated BMS is incorporated into the proposed system. The BMS acts as a monitoring and control unit, continuously assessing the state of charge (SOC) and temperature of each individual battery pack. This data-driven approach enables the system to intelligently switch between battery packs based on their specific conditions. By doing so, the system ensures optimal utilization of each battery pack, preventing overcharging or over-discharging, and ultimately prolonging the lifespan of the batteries.

Moreover, the proposed system features a regenerative braking system, which capitalizes on the SRM's capability to generate energy during deceleration and braking. This regenerative braking mechanism converts the kinetic energy of the vehicle into electrical energy, which is then stored in the battery packs for future use. This additional energy recovery further enhances the system's overall efficiency and contributes to the sustainable operation of electric vehicles.

One of the remarkable advantages of the proposed system is its scalability. As new batteries with improved capabilities become available, the multi-battery system can be easily upgraded

or replaced, ensuring that the electric vehicle remains at the forefront of efficiency and performance

The control strategy of the SRM system is illustrated in Figure 3.2, depicting a block diagram that incorporates a PWM control method. This control system offers remarkable precision, allowing for easy regulation of phase current and excitation voltage by adjusting the duty cycle of the PWM wave. The utilization of PWM control results in high control accuracy and favorable outcomes.

The control system produces the necessary switching signals by evaluating the disparity between the reference speed set for the motor and its real-time velocity. The encoder is employed to detect the rotor position, which enables the computation of the speed. Utilizing this data, the appropriate angles for initiating and terminating phases are determined to facilitate the process of phase commutation. To attain closed-loop control, precise regulation of the motor speed is achieved through the implementation of a proportional integral (PI) controller.

5.2 Future Recommendations

In the future, it is recommended to explore the integration of advanced machine learning algorithms and predictive control techniques to further optimize the performance and energy regeneration of the proposed system. Additionally, research and development efforts should focus on advancing battery technologies, such as solid-state batteries or lithium-sulfur batteries, which have the potential to offer higher energy densities and improved longevity.

References

- [1] S. Kimura, Y. Itoh, W. Martinez, M. Yamamoto, and J. Imaoka, "Downsizing effects of integrated magnetic components in high power density DC/DC converters for EV and HEV applications," *IEEE Trans. Ind. Appl.*, vol. 52, no. 4, pp. 3294-3305, 2016.
- [2] D. Moon, J. Park, and S. Choi, "New interleaved current-fed resonant converter with significantly reduced high current side output filter for EV and HEV applications," *IEEE Trans. Power Electron.*, vol. 30, no. 8, pp. 4264-4271, Aug. 2015.
- [3] A. Kulvanitchaiyanunt, V. C. P. Chen, J. Rosenberger, P. Sarikprueck, and W. J. Lee, "A linear program for system-level control of regional PHEV charging Stations," *IEEE Trans. Ind. Appl.*, vol. 52, no. 3, pp. 2046-2052, May./Jun. 2016.
- [4] L. Herrera, E. Inoa, F. Guo, J. Wang, and H. N. Tang, "Small-signal modeling and networked control of a PHEV charging facility," *IEEE Trans. Ind. Appl.*, vol. 50, no. 2, pp. 1121-1130, Mar./Apr. 2014.
- [5] A. Chiba, K. Kiyota, N. Hoshi, M. Takemoto, and S. Ogasawara, "Development of a rare-earth-free sr motor with high torque density for hybrid vehicles," *IEEE Trans. Energy Convers.*, vol. 30, no. 1, pp. 175-182, Mar. 2015.
- [6] K. Kiyota, and A. Chiba, "Design of switched reluctance motor competitive to 60-kW IPMSM in third-generation hybrid electric vehicle," *IEEE Trans. Ind. Appl.*, vol. 48, no. 6, pp. 2303-2309, Nov./Dec. 2012.
- [7] F. L. M. d. Santos, J. Anthonis, F. Naclerio, J. J. C. Gyselinck, H. V. d. Auweraer, and L. C. S. Góes, "Multiphysics NVH modeling: simulation of a switched reluctance motor for an electric vehicle," *IEEE Trans. Ind. Electron.*, vol. 61, no. 1, pp. 469-476, Jan. 2014.
- [8] Q. Sun, J. Wu, C. Gan, Y. Hu, N. Jin, and J. Guo, "A new phase current reconstruction scheme for four-phase SRM drives using improved converter topology without voltage penalty," *IEEE Trans. Ind. Electron.*, vol. 65, no. 1, pp. 133-144, Jan. 2018.
- [9] C.-Y. Lim, Y. Jeong, M.-S. Lee, K.-H. Yi, and G.-W. Moon, "Halfbridge integrated phase-shifted full bridge converter with high efficiency using center-tapped clamp circuit for battery charging systems in electric vehicles," *IEEE Trans. Power Electron.*, vol. 35, no. 5, pp. 4934-4945, May 2020.
- [10] D. Yu, Y. Hua, S. Yu, P. Zhang, H. H. C. lu, and T. Fernando, "A new modulation-demodulation approach to DC power-line data transmission for SRG-integrated microgrid," *IEEE Trans. Power Electron.*, vol. 35, no. 11, pp. 12370-12382, Nov. 2020.

APPENDIX

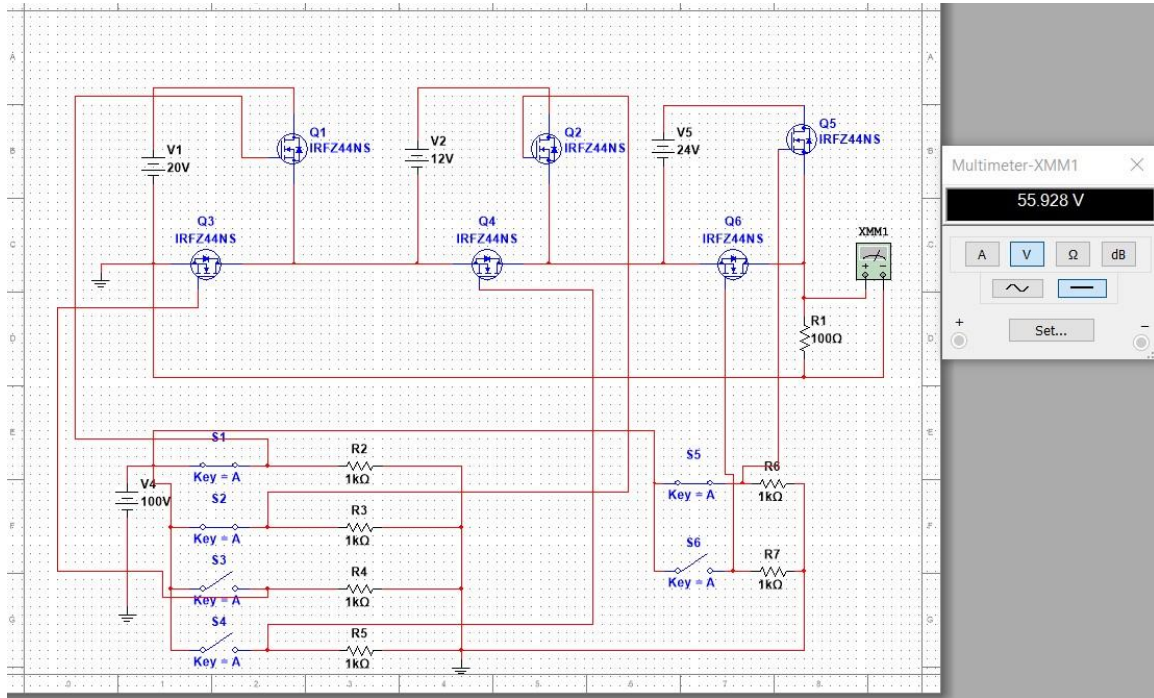

Multimeter-XMM1

55.928 V

A V Ω dB

~ -

Set...

+ -

Motor

ORIGINALITY REPORT

8%

SIMILARITY INDEX

PRIMARY SOURCES

1	ijareeie.com Internet	42 words — 1%
2	www.electrical4u.net Internet	39 words — 1%
3	www.iejrd.com Internet	39 words — 1%
4	research.hip.fi Internet	34 words — < 1%
5	www.frontiersin.org Internet	33 words — < 1%
6	fourier.eng.hmc.edu Internet	22 words — < 1%
7	Ercument Karakas. "Speed control of SR motor by self-tuning fuzzy PI controller with artificial neural network", Sadhana, 10/2007 Crossref	20 words — < 1%
8	dias.library.tuc.gr Internet	18 words — < 1%
9	zombiedoc.com Internet	17 words — < 1%

- 10 patents.google.com
Internet 14 words — < 1%
-
- 11 www.cosenggroup.com
Internet 14 words — < 1%
-
- 12 Pasala Gopi, Pinni Srinivasa Varma, Ch Naga Sai Kalyan, C. V. Ravikumar et al. "Dynamic Behavior and Stability Analysis of Automatic Voltage Regulator with Parameter Uncertainty", International Transactions on Electrical Energy Systems, 2023
Crossref 12 words — < 1%
-
- 13 escholarship.org
Internet 12 words — < 1%
-
- 14 impactjournals.us
Internet 12 words — < 1%
-
- 15 lup.lub.lu.se
Internet 12 words — < 1%
-
- 16 Yong Chen. "New Energy Vehicle Powertrain Technologies and Applications", Springer Science and Business Media LLC, 2023
Crossref 11 words — < 1%
-
- 17 livrepository.liverpool.ac.uk
Internet 11 words — < 1%
-
- 18 Fengyuan Yu, Hao Chen, Wenju Yan, Dalin Zhou et al. "Performance Improvement for Double-Stator Axial Flux SRM Using a New Winding Reconfigurable Power Converter", IEEE Transactions on Transportation Electrification, 2023
Crossref 10 words — < 1%

19	iosrjournals.org Internet	10 words — < 1%
20	mtadese.com Internet	10 words — < 1%
21	www.springerprofessional.de Internet	10 words — < 1%
22	Qingguo Sun, Jianhua Wu, Chun Gan, Jifeng Guo. "Modular Full-Bridge Converter for Three-Phase Switched Reluctance Motors With Integrated Fault-Tolerance Capability", IEEE Transactions on Power Electronics, 2019 Crossref	9 words — < 1%
23	Shota Kimura, Yuki Itoh, Wilmar Martinez, Masayoshi Yamamoto, Jun Imaoka. "Downsizing Effects of Integrated Magnetic Components in High Power Density DC-DC Converters for EV and HEV Applications", IEEE Transactions on Industry Applications, 2016 Crossref	9 words — < 1%
24	Shouyi Han, Kaikai Diao, Xiaodong Sun. "Overview of multi-phase switched reluctance motor drives for electric vehicles", Advances in Mechanical Engineering, 2021 Crossref	9 words — < 1%
25	Xingcun Colin Tong. "Chapter 12 Development and Application of Advanced Thermal Management Materials", Springer Science and Business Media LLC, 2011 Crossref	9 words — < 1%
26	eprints.lib.hokudai.ac.jp Internet	9 words — < 1%
27	hal.science Internet	9 words — < 1%

-
- 28 publications.aston.ac.uk 9 words — < 1%
Internet
-
- 29 theses.gla.ac.uk 9 words — < 1%
Internet
-
- 30 Dragan S. Mihic, Mladen V. Terzic, Bogdan M. Brkovic, Slobodan N. Vukosavic. "A novel modular power converter for SRM drive", Electrical Engineering, 2020 8 words — < 1%
Crossref
-
- 31 Karel Slobodnk. "Detection and evaluation of subsurface defects using pulse eddy current differential probe", 2017 18th International Conference on Computational Problems of Electrical Engineering (CPEE), 2017 8 words — < 1%
Crossref
-
- 32 M.A. Hannan, M.M. Hoque, A. Mohamed, A. Ayob. "Review of energy storage systems for electric vehicle applications: Issues and challenges", Renewable and Sustainable Energy Reviews, 2017 8 words — < 1%
Crossref
-
- 33 Sunil Kumar Sailapu, Neus Sabaté, Eric Bakker. "Self-Powered Potentiometric Sensors with Memory", ACS Sensors, 2021 8 words — < 1%
Crossref
-
- 34 Wu, Hongyang. "Evaluation of Shear Tab Connections as Supplemental Energy Dissipators", Auburn University, 2023 8 words — < 1%
ProQuest
-
- 35 essay.utwente.nl 8 words — < 1%
Internet
-
- 36 usermanual.wiki 8 words — < 1%
Internet

8 words — < 1%

37 www.columbia.edu
Internet

8 words — < 1%

38 www.tc.faa.gov
Internet

8 words — < 1%

39 www.yumpu.com
Internet

8 words — < 1%

40 Dingyü Xue. "6 Subsystems and block masking",
Walter de Gruyter GmbH, 2022
Crossref

7 words — < 1%

41 Vincent L. Pisacane. "The Space Environment and
Its Effects on Space Systems, Second Edition",
American Institute of Aeronautics and Astronautics (AIAA), 2016
Crossref

7 words — < 1%

42 Robert Risebrough. "Conservation biology: Fatal
medicine for vultures", Nature, 02/12/2004
Crossref

6 words — < 1%

43 Xiaoshu Zan, Guanqun Xu, Tiejun Zhao, Ruiming
Wang, Linwang Dai. "Multi-battery Block Module
Power Converter for Electric Vehicle Driven by Switched
Reluctance Motors", IEEE Access, 2021
Crossref

6 words — < 1%

EXCLUDE QUOTES ON

EXCLUDE SOURCES

OFF

EXCLUDE BIBLIOGRAPHY ON

EXCLUDE MATCHES

< 6 WORDS