

# CHAPTER I

## 1.1 Background of the Study

Since early 1990s new initiatives for ICS dissemination create new stoves design, which can be built completely from cheap readily available local materials. The target oriented approach was abandoned and replaced by a subsidized bottom up and demand driven approach. The development of mud brick stove by Research Center for Applied Science and Technology, Nepal (RECAST) in early 90s. ICS was promoted and disseminated by various organizations with different financial arrangements such as with and without subsidies, equity participation by users etc. ICS became an important and integral component of development initiatives and was supported by quite a number of programs, donor agencies and promoting/disseminating organizations. In 1995, ICS network supported by Asia Regional Cook Stove Program (ARECOP) and managed by Centre for Rural Technology, Nepal (CRT/N) was established. The network is aimed at bringing together various organizations working in ICS promotion and dissemination and expanding the utilizations of ICS. The network has concentrated its effort in bringing uniformity among approaches of various organizations involved by advocating a bottom of a subsidyless approaches.

Nepal is surrounded by village. Most of the people living in rural areas depend on agriculture. They have no access of the electricity so they have to depend on forest to meet their demand of energy. Despite the effort to develop new and alternative energy sources, still the vast majority of the people will have to depend on biomass such as fuel wood for satisfying their basic energy consumption in relation to cooking, heating, and lighting. Cooking in these areas is carried out in traditional stoves like three stones mud and tripod which is not beneficial from economic as well as health point view. More fuel wood consumption and smoke related diseases are the major drawbacks in these types of stoves. Accessibility of general people in the use of electricity, LPG gas and kerosene oil in the rural areas is very low. In 1995/96 80% of the national energy consumption was based on the fuel wood, almost all (98%) of the 80%, the energy consumption is based on traditional biomass resources of energy such as fuel wood, agricultural residues and animal dung. As a result of continuing forest degradation, the share of fuel wood energy consumption pattern is in declining trend. Consequently fuel wood is increasingly being replaced by lower grade fuel

such as agricultural residues. The current energy consumption pattern has implications not only on the rural energy sector but also on the agro-forestry sector, rural economy, health and particularly to those who are directly involved in the collection and consumption of the bio-mass for cooking namely by the women and children. The high prevalence of respiratory related diseases (chronic bronchitis and others) among women population in Nepal was probably primarily due to their exposure to domestic smoke while cooking (pandey, 1988). Apart from the negative effects on their health (respiratory and eye- related) on women and girl children of rural mass population, the drudgery on the collection and use of fuel wood is severe.

Use of traditional stoves such as “agenu” and “chulo” consumes more fuel woods and increases the burden on women. Women are mainly responsible for cooking and collection of bio-mass, mainly fuel wood from the forest. Use of biomass energy and low grade biomass fuels lead to excessive level of indoor smoke/air pollution. Women and children in particular are exposed to the smoke emission. This is one of the reasons for higher rate of infant mortality and morbidity and other unhealthy living conditions. Release of incomplete carbon gas and other harmful particles in the atmosphere due the poor combustion of biomass fuel in rudimentary stoves results the emission of green house gas. More then 80% of the energy needs are met by fuel wood thus exerting immense pressure on the forest resources of the country with negative impacts on environment. In order to achieve reduction on indoor air pollution and increase fuel efficiency and protect the forest resources and environment, ICS development and dissemination activities were initiated in Nepal from early 1950s with the introduction of some Indian models Hyderabad and magan stoves. Since then a number of improved cooking stove programmes have been promoted in rural communities of Nepal. In early 1970s, the focus was on improving the fuel efficiency of the stoves. During 1980s interest and efforts were revived when the national planning commission included ICS in its development plan as an attempt to address the pressing fuel wood problem. The government’s concern for fuel wood conservation was also reflected with the inclusion of ICS dissemination efforts as an important component of food and agriculture organization (FAO) of the United Nations assisted community forestry development project (CFDP) IN 1981. Besides other donor organization as well as INGOs initiated promotion and dissemination of ICS in various region of Nepal with the top down and supply driven approach. With

the combined effort of the government and NGOs, basically through the community forestry development project, about 5700 ceramic prefabricated models of ICS were disseminated in the different parts of the country. However, the prefabricated models turn out to be not as appropriate as substantial breakage occurred during the prolonged and difficult transportation process in hills and mountain areas. Thus ICS efforts in Nepal during 1980s delivered mixed results and limited successes.

Within the frame of the 9<sup>th</sup> plan, the national ICS program has been initiated in Nepal from early 1999 with the support from Energy Sector Assistance Program (ESAP) of DANIDA and Alternative Energy Promotion Center (AEPC) of the HMG/N. Many district level NGO and CBOS like the Centre (CRT/N) implements this program. The program has been currently promoting ICS in 33 mid-hill districts of the country. The type of ICS promoted is made up of three parts mud/earth, two parts straw /husk and one part animal dung. The whole structure is plastered smooth with the same mud mortar. ICS has two fire openings for cooking pots, one behind the other.

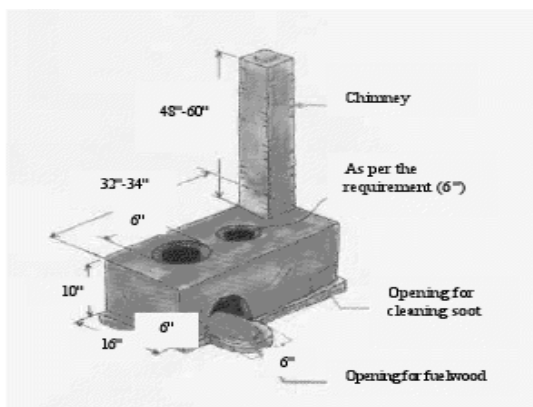

**Technical Specification of Two Pot Hole ICS**

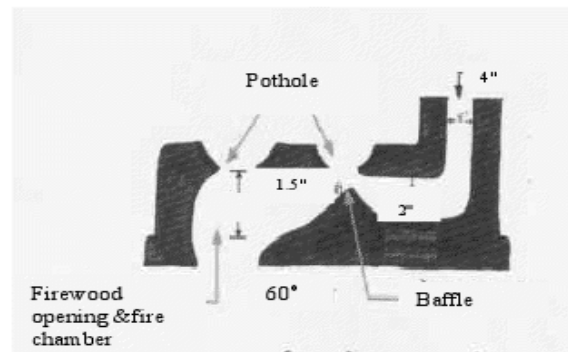

In Nepal, women are mainly responsible for cooking activities and collecting firewood. studies have shown that ics has efficiency of 15.25% and fuel saving is 30-35% thus favoring the drudgery reduction on women as ics cuts down their cooking time and hardship in collection in scarce fuel wood. women and their children are generally exposed to indoor air pollution. the indoor air pollution due to the combustion of biomass fuel is the main cause of acute respiratory infection(ari).chronic obstructive lung diseases (cold),eye infection and pneumonia in women and children. Studies have shown that with the use of ICS human exposure to pollutants in the kitchen environment has been reduction by an average of 69% carbon monoxide concentration, 53% total suspended particle(tsp)concentration. The

majority of the women using ICS have responded that they had asthma and eye burning due to traditional stoves but also that the situation has improved after installation of ICS and they don't suffer from burning eyes and breathing problems.

Indeed, in nearly all developing countries biomass represents about 80% of the energy balance use for cooking purposes. This biomass is used in very inefficient stove and wasting a lot of energy. In this fact contributes to the continuing process of deforestation in developing countries. Biomass is the most important source in Nepal and technologies that improve efficiency of biomass use are essential for the country's development and improvement of living conditions, particularly of rural poor. Improve cook stoves and biogas are the most successful biomass energy technologies in use in Nepal today as they have been developed and adopted over the years to suit local conditions. Emerging biomass energy technologies include briquettes, gasifiers, cogeneration and liquid bio fuels. Alternative Energy Promotion Centre (AEPIC)/ Energy Sector Assistance Program (ESAP) is promoting research and development on these technologies so as to improve their performance and ensure their wide scale application.

Mud brick ICS is particularly one of the most simple, in expensive and widely use technologies designed to improve combustion efficiency of biomass and reduce exposure to indoor air pollution. The benefits of ICS includes : Increase thermal efficiency ,conservation of forest by reducing fuel wood consumption, reduction in women's drudgery ,reduction indoor air pollution and hence smoke related health disorder, and prevention of fire hazards. Traditional stoves used in Nepal are simple structures made from clay or having stones or metal tripods'. These stoves are very efficient because they have poor air flow and insulation. As a result, they consume a lot of biomass and produce high level of indoor air pollution.

ICS was introduced in Nepal in 1950s and continues to be relevant at the present context. AEPIC/ESAP, together with other government ,and non-government and private organizations, is involve in developing and promoting different types of ICS in Nepal and so far more than 2,00,000/- improved cook stoves have been installed in Nepal particularly in the mid -hill.

The energy source use in households is often linked to socio-economic condition. People with low income and traditional life style depend more on solid biomass fuels. As people’s income level increases, they tend to climb up the energy ladder and start using relatively cleaner fuels such as Kerosene, LPG and electricity. It is estimated that about 50% of the World’s population are still at the bottom of this energy ladder as they use solid biomass fuels such as fuel wood dung and agricultural residues. The situation is worse in Nepal as 85% of Nepal’s population depend on solid biomass fuel for cooking. Of the total energy consumed in Nepal, it is estimated that about 75% comes from fuel wood and 9.5% comes from agricultural residues and dung, while only about 2% comes from electricity and renewable energy source.

**Pie-Chart -1 : Source of Energy**

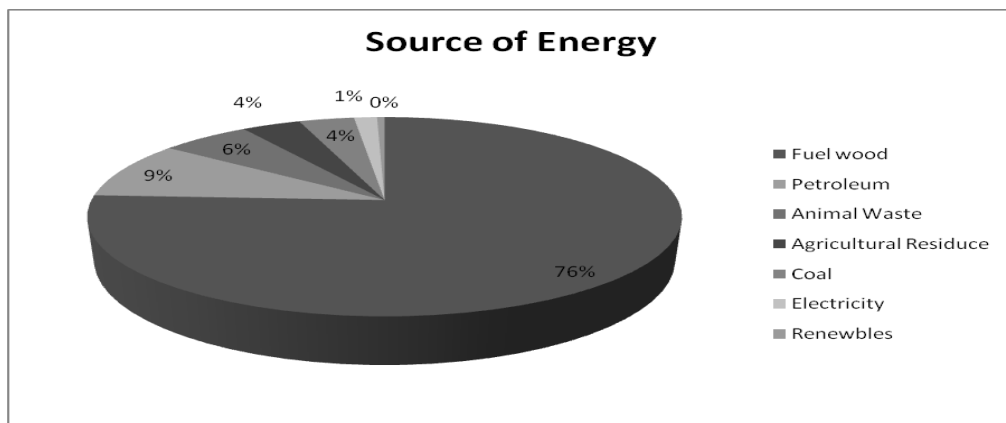

*Source: Economic Survey ,2006-07(AEPC)*

Similarly, a total of 556.4MW of hydro power (0.67% of total potentials) was generated from various power projects and the end of FY 2005/06 . Out of total generated hydropower,550.225MW is connected in national grid and remaining electricity generated by other medium hydropower centres is providing this service to various local areas . At the same way, energy produce from thermal power plants and solar plants has been 55.028MW and 100KW respectively . This adds up to 611.529MW of total energy production(MoF,2007).

By NPC the positive rate of renewable energy technology for the fulfillment of energy needs of the rural people was recognize during five years plan period after 7<sup>th</sup> five year plan. The 10<sup>th</sup> five year plan emphasized on developing and promoting renewable energy technologies based on local resources and tools.Reducing

dependency on imported energy and by improving and increasing the energy use competency and increasing the access of the rural people by reducing the cost of development and installation of RET(NPC,2003).The heavy demand of wood for cooking and heating causes an enormous and physical burden on thousands of people in our country.The over population of the forest for fuelwood have placed the forest under heavy pressure(RECAST,2000).However the development and dissemination of various techniques in rural areas are very limited.Therefore rural people are forced to burn lower quality fuels such as twigs,branches,crop residue,animal dung and even weeds or grasses.The situation has worsened by the use of an inefficient cooking stoves resulting in a high consumption of fuelwood. In a view of rapidly dwindling forest the development and promotion of the improved fuelwood stoves or improved cooking stoves became one of the most important component of the fuelwood management program as they can save (18-42%) of the fuelwood (Shakya,1985) .

Improved Cooking Stoves is to assist people in managing locally available resources through reducing their essential needs for fuelwood . Additional benefits from ICS improve the quality of the household environment. It appears that those “ additional “ benefits play a major role in the adoption of this new technology .Further the users of ICS indicate that benefits related to health ,safty and household chores enhance extension of the program from initial users households to village neighbours and relatives in nearby village .

**Table 1.2: Sectoral Energy Consumption at different year in percentage**

Sector	1999	2000	2001	2002	2003	2004	2005
Residential	91.53%	89.25%	89.75%	90.58%	90.59%	90.17%	90.28%
Industrial	2.39%	4.75%	3.88%	3.61%	3.39%	3.79%	3.47%
Commerical	1.03%	1.12%	1.23%	1.42%	1.48%	1.47%	1.45%
Transport	4.72%	3.87%	4.05%	3.46%	3.59%	3.63%	3.78%
Agriculture	0.25%	0.90%	0.94%	0.80%	0.82%	0.80%	0.84%
Others	0.11%	0.11%	0.12%	0.13%	0.14%	0.15%	0.17%
Total	100%	100%	100%	100%	100%	100%	100%

*Source: WECS 2006*

The residential sector consumes almost 90% of the total energy in 2004 -5, where, almost 25% energy is met by fuelwood . So, to reduce health risk and save fuelwood, ICS is an important factor needed to promote rural areas.

Thus an appropriate energy strategy is important toward tackling the current problem of environmental degradation caused in large part by clearance of the large part of the forest for firewood .To meet future firewood demand and arrest ecological degradation, various reports suggested for plantation of additional tree for firewood .

A study shows that the total energy consumption in Nepal in 2005/06 was 8336.42 TOE which was decreased by 1.67% to 8178 TOE compared to 2004/2005(economic survey common 2005/06).In order to overcome the scarcity as well as to improve biomass use a change in balance between biomass energy consumed by the domestic and other productive sector is essential.

So the dissemination of the improved stove is considered as the single most important short run action for energy conservation.Improved stoves directly address containing the urgent problem of deforestation and the scarcity of domestic fire woods.It doesn't require complex technology all more investment.

## **1.2 Statement of the Problem**

In Nepal, primarily women carry the cooking activities. Besides, rural women often play an important role in collection of biomass, fodder and water. The supply of biomass is a serious concern in the past few years .It is due to over exploitation of forest for fuel wood and fodder as well as the agricultural food production demands of growing population. These result a serious impact on women's access to source of biomass energy. For the use of traditional stoves "Aghu" and "Chulo" that consume more fuel increases the drudgery on women to cook. Besides, using biomass energy and low grade biomass fuels leads to excessive level of indoor air pollution. Women and children of rural and poor families are particularly exposed to smoke emission. This is one of the reason of higher rate of infant mortality and morbidity. Poor combustion of biomass fuels results greenhouse gas(GHG) effect due to emission of incomplete carbon products in the atmosphere . Furthermore, the firewood used in the traditional "Chulo" is inefficient and does not exploit the end use efficiency of the

firewood. In addition 46% of traditional stove users are suffering from respiratory diseases (Joshee, 1986:2) Viewed in the context of health hazards and excessive use of firewood in the traditional stoves. The propagation and adoption of improved cook stoves have both long and short implication for future development efforts. The economic realities of Nepal also highlight the importance of improved cook stoves as 60% of its income is annually spent on importing other sources such as petrol ,kerosene etc. from other countries.

Primarily, in Nepal, women are mostly involved in the cooking activities. Besides, rural women often play an important role in collection of biomass, fodder and water. The supply of biomass is a serious concern in the past few years. It is due to over exploitation of forests for fuel wood and fodder as well as the agricultural food production demands of growing population. These result a serious impact on women's access to source of biomass energy. Further, the use of traditional stoves "*Aghu*" and "*Chulo*" that consume more fuel increases the drudgery on women to cook. Besides, using biomass energy and low-grade biomass fuels leads to excessive levels of indoor air pollution. Women and children of rural and poor families are particularly exposed to smoke emission .This is one of the reason of higher rates of infant mortality and morbidity. Poor combustion of biomass fuels results greenhouse gas effect due to emission of incomplete carbon products in the atmosphere. Furthermore, the firewood used in the traditional "chulo" is inefficient and does not exploit the end use efficiency of the firewood. In addition, 46% of traditional stoves users are suffering from respiratory diseases (Joshee,1986:2) viewed in the context of health hazards and excessive use of firewood in the traditional stoves. The propagation and adoption of ICS will have both short and long term implication for future development efforts. The economic reality of Nepal also highlight the importance of ICS as 60% of its income is annually spent on importing other sources, such as petrol, kerosene etc. from other countries.

With the development of proper institutional setup effective dissemination and involvement of the government and donor agencies this alternative energy technology could make significant contribution in meeting the rural energy needs. The ICS technology is emerging as an important alternative energy source not only of rural household cooking but also for commercial purposes. To tackle for improving the



global problem, the renewable energy sources are to be developed and ICS promotion will be a significant one. So for the development and dissemination of modern technology social research studies are to be carried out as it is related to social and cultural practices, thus it will advantage for ICS development in rural areas.

In this context, ICS can play important role for efficient utilization of fuel wood in terms of saving the quantity of fuels and cooking time reduction in health hazards and green house gas emission, and lowering the pressure on forest for fuel wood extraction (TRUST-2006) . The demand for energy for domestic purpose is being more difficult to meet the task of gathering and fetching is a time consuming burden. If farm families are relieved from this activity, they could utilize the spare time gained for economic activities.

Due to rapidly growing population the demand firewood is increasing in rapid rate. The population growth rate is 2.25% per year (CBS-2001). Some domestic energy consumption pattern studies by Tata Energy Research Institute in India shows that 90% of households in rural area, 75% of semi-urban area, and 25% of the households in the urban area use firewood stoves . Fuel wood conservation is a burning question for countries, faced with limited oil supplies, rising fuel prices and dwindling forest resources which cause environmental pollution, health related problems and other many hazard in the society . (Prasad-1982)

The problem of fuel wood is more threatening than in usually realized. Unless, adequate measure are taken, the fuel wood supply for some thousand million people will be so critical by the coming air that they are no longer able to cook their food adequately (Prasad-1982). Further, 2000 million on none will then be facing similar critical shortages within one or two decades as more woods is cut, deserts will spread ,we may be heading for a famine worse than any known famine in history for the large majority of the population involved, there is now alternative to using wood, charcoal or agriculture wastes in the current international economic order . Imported fossil fuels are too expensive and the infrastructure to insure their availability is lacking. Increasing the supply of the biomass fuels and using them more efficiently will be vital tasks in the coming decades .

To achieve substantial reduction in indoor air pollution and increased fuel efficiency, various organizations are involved in improved cook stoves development and dissemination in Nepal. These organizations considered improved cook stoves (ICS) as one of the several tools available to combat indoor air pollution and deforestation.

One of the key characteristics of these cook stoves program is its ability to utilize the local manpower and create a condition of self-sustaining process of diffusion using locally available recourses, unaided by external market intervention.

The selected study area is not so far from the above mention problem but to identify the actual perception of people about ICS, their knowledge and attitude of using fuel for cooking, utility of ICS and their accessibility and affordability survey was the main aim of the study.

### **1.3 Objectives of the Study**

The general objective of this study is to assess the performance and impact of ICS program on rural women in the study area. The specific objectives of this study are:

To examine the performance of ICS in the study area.

To assess the health and socio-economic impact of ICS on women.

To identify the changes in the living conditions of the users before and after the installation of ICS.

### **1.4 Limitation of the Study**

The study consists limited geographical area and limited households. More than one hundred thousands of improved cook stoves have been operating all over the country. The present study deals with only one VDC of Nuwakot district. Another limitation of the study is that the present study has been concentrated only with the ICS operators and has not been concentrated with non-users. Similarly, most of this research study is based on descriptive analysis. No sophisticated statistical technique is adopted. Besides, the study has following limitations which may lead to the study up to a case study but not to more specific findings.

Although alternative energy technology determines the different type of energy technologies according to time, place and circumstances such as solar, improved water Mill, Micro Hydropower, wind power, improved cooking stove, biogas etc., but only the improved cook stove has been taken as an alternative energy for this study. It is not possible to explain these issues in boarder sense of alternative energy technology.

The people of the study area occupy the heterogeneous socio-cultural and economic performances and the diverse status of various people encompassing different cast, ethnicity comprises the various aspects of living. It is difficult to find the more specific findings such as impact of improved cook stoves on socio-economic status, environment, gender issues and technical know-how which is very vague study so only the performance study and socio-economic impact on women is try to dig out from the study.

ICS is not suitable for space heating and not portable.

Although this technology is well established in Nepal, there is still a need for further scaling of their use throughout Nepal.

The study has the limited boundary of geographical area which is a small village area and a VDC of Nepal due to the limitation of time and budget.

The study has the contextual findings .Hence; the findings of the study may not be generally conclusive for other area.

## **1.5 Rational of the Study**

Energy is essential for development and per capita energy consumption is often seen as an indicator of economic status and well being .Nepal's per capita energy consumption at 0.3 ToE (15 GJ) is one of the lowest in the world and more than 90 percent of this energy is consumed in the residential sector, indicating the low use of energy for economic development related activities.

Besides, being an indicator for economic development, household energy also has multiple linkages with important social issue related to poverty, gender, environment and health. Generally, poor people tend to use solid biomass based fuels such as fuel

wood, animal dung and agricultural residue which causes many environmental and health problems at local as well as global levels. The loss of time and productivity due to environmental and health problems associated with solid fuels use further aggravates poverty and the adverse impact is primarily on women as they are often the ones involved in collection and use of fuel at household level.

Hence, the study is an effort in promotion of alternative /renewable energy which can reduce the energy crisis and is brings the technical awareness to rural people to adopt the renewable energy technology. Indeed, it helps to promote the sustainable energy consumption pattern of rural people for rural development.

A number of researches have been made on the topic of ICS in Nepal. Some of them deal with the feasibility study, need, dissemination and development regarding the ICS. In the context of increasing scarcity of firewood and other consequences resulting from forest depletion, the research of alternative energy sources is most essential in rural areas of Nepal. However, it is not possible to take action fast to create measures and implement. So that, certain measures are required protecting large-scale deforestation in the different parts of Nepal annually. For this purpose, ICS can play vital role to reduce the deforestation. While local ICS users are conscious regarding present as well as future problem due to deforestation and firewood related diseases, it will be helpful for policy makers, other concerned institutions and agencies to make proper decision regarding the ICS and its users in proper time. Different development agencies have been existed for proper development of Improved Cooking Stoves in Nepal; however, micro level analysis is very difficult to carry out in the grass root level. In this context, this research can contribute for needed literature in the field of ICS. In this regard, the present study deserves its own importance. First of all, the research try to provide an idea about the performance of ICS users and its impact is drawn and they can provide the key information for further research works in this field.

The potential for ICS technology is obvious in the rural areas especially of in accessible villages where deforestation is increasing rate and other commercial fuels are economically not feasible. The major used of ICS is cooking food items of daily needs which are the reliable source of energy for it. It has significantly improved the quality of life of the family members and their health and the made the works of the

family members especially the women and the girl children much easier. It also helps to improve child education due to increase study hours and decrease in eye and respiratory health problems. On the economic point of view, ICS opens up new economic opportunities in rural areas. The dissemination of ICS has directly helped in skill development and employment among rural local people to some extent.

Assessment of the impact of ICS users, their activities and utilization of ICS from the rural scenarios to develop, Clean Development Mechanism (CDM) will be of more importance for recommendation to planners and policy makers to formulate appropriate plan for further development of the study. The study is important for investigating the changes in the status of activities of ICS user's households in the study area.

Furthermore, it is expected that the research is being a substantial importance for planners, policy makers and other social scientists. It can also provide an input to the students, teachers and researchers in these areas of ICS. In the same way, the NGOs and INGOs is an input to plan and implement ICS related programs in the rural area of Nepal.

## **1.6 Organization of the Study**

The study includes six chapters in total.

The first chapter – Introduction, Statement of the Problem, Objectives of the Study, Limitation of the Study, Rational of the Study.

The Second Chapter- Literature Review

Third Chapter- Research Methodology, which includes research design, rational of the selection of the study area, data collection techniques and tools, finally data presentation and analysis.

Chapter Four- Background of the study area

The chapter five discusses the presentation and analysis of data collected from the household survey.

The chapter six is full of summary, conclusions and recommendations.

## **CHAPTER II**

### **LITERATURE REVIEW**

#### **2.1 Theoretical Review**

It is simple and cost effective technology which has users multiple benefits i.e. increased thermal efficiency, conservation of forests, cut back in fuel wood consumption, reduction in women's labour, reduction in indoor air pollution and hence smoke released health disorders, prevention of fire hazards reduction of cooking time. It works on the principle of reduction in smoke emission and increased efficiency, flame concentration under first burner and then channeling the heat forward to the second burner to cook two items at a time. In rural areas of Nepal most of the households use biomass resources to fill their required energy consumptions because there is no alternative energy source except fuel wood. (AEPC-2000)

The efficiency of these improved cooking stoves is found to be 25-40 percent and the potentials fuel saving toward r un-baked bricks, slate and small gavel whatever is available in the area suitable for construction. Members of INGOs, NOGs and CBO are working for the promotion, development and dissemination of ICS. Among them Terai Area landscape project has made a slogan "more energy from less firewood" for ICS.

#### **2.2 Conceptual Review**

Due to the population growth and increased urbanization the demand of biomass energy is rapidly growing and an encase in the various types of economic activity as well as growing aspirations of rural communities for better living standards. This has lead to over exploitation of biomass (wood) resources for fuel and other user & clearing of forest for agricultural land causing a serious problem in fuel wood supply and environment degradation further adding drudgery to women. The unsustainable use of biomass is creating increasing hardship for local users who most travel long distance to collect fuel wood and other biomass resources. (Thapa, 2006)

Exploitation of the forest for fuel wood, fodder & timber along with the agricultural demands of the growing population has placed forest under heavy pressure reducing

forest & thus damaging the environment. As a result, current rural households' energy supplies and consumption patterns are of a serious concern.

For the promotion, dissemination and development of ICS, many researchers and reference have been done.

Improved cooking stoves have become one of the most important components of the fuel wood management program, as they can save 18 to 42 percent of fuel wood. (Shakhya-1985)

The efficiency of improved cooking stove is 25 to 40 percent. (Sulpya-1996)

A health development project has been estimates about 33 percent of Improved Cook Stoves user in Surkhet district demonstrated change in work pattern because ICS cooked faster and food is kept warmer for a long period of time .(WECS,1994/95)

ICS works on the principle of increasing the concentration of heat directly under the first cooking pot and then channels the heat back to the second burner to cook two pots at a time, it conserves heat and reduces heat dissipation which minimum waste 30 to 50 percent fire wood could be saved through the proper use of Improved Cooking Stoves (CFDP, 1984).

An improve cooking stoves “ Noda Chula” that could reduce fuel wood consumption & improve the women's quality of life developed between June 1982 to April 1983. It emerged as a response to the women's request for smoke removal from their kitchens. The experience of working with village women has demonstrated the importance of making technology adoptable to varying needs (Clarke, 1985).

Majority of the users around 87% are experiencing the reduced smoke status in the kitchen and only 13% are not convinced with smoke reduction features of ICS (Trust, 2006).

Employed person, educated person, large family, rich person were the users of improved stoves. (Joshee, 1986)

According to wood 1987, ceramic insert type stove has been mostly abandoned in favor of stoves built on the site from locally available materials.

According to the recent report of RECAST traditional stove gave an average efficiency of 19.76% with an average power output of 11.99 KW. boiling 16kg of water in 53 minutes consuming 43gm of fire wood per minute .Similarly, closed combustion chamber stove with one meter high chimney gave average efficiency of 21.47percent with an average power output of 24.61KW boiling 16 kg of water in 24 minutes consuming 76.44gm of firewood per minute.

The improved cook stoves provide better living condition as enclosing the fire and removing smoke from the kitchen through a chimney which cause a safer and healthier home environment .A well managed improved cook stove can save considerable time in food preparation house cleaning, fuel gathering and energy comparatively then the unmanaged tripod at home made mud stove system (AEPC, 2000).

Intervention efforts have also focused on removing the polluted air out of the living environment instead of replacing the fuels themselves. The dissemination of improved cook stove(s) (ICS) gained momentum out of the concern in the 1970s that the over-reliance on wood fuel was depleting natural forest resources at an unsustainable rate. It was envisaged that the resulting deforestation and contributions from biomass fires to greenhouse gas emissions would have significant impacts on global climate patterns (Ahuja et al. 1987). The second concern was that as natural forest resources became depleted, people (mostly rural women) would have to walk increased distances to collect wood. Studies showed that women in some rural contexts were spending an average of two hours collecting fuels and carrying loads of 24 kilograms of wood per day, with significant health and welfare implications (Goldemberg J. 1996).

Third, in areas where biomass fuels were purchased, fuel expenditure accounted for a significant proportion of poor households' energy budgets. Traditional open fires are highly inefficient. The answer, it was believed, was to improve the efficiency of the burning process through the use of ICSs. People would consequently use proportionally fewer units of fuel per burning resulting in cost savings in contexts where fuels were bought, and time savings where fuels were collected. It would also have the added environmental benefit of reducing deforestation.



Governments and donor agencies in developing countries enthusiastically embraced improved cooking appliances with over 129 million ICSs disseminated in China alone. Current estimates indicate that over 160 million ICSs have been disseminated in developing countries. Indeed, observational studies in developing countries have shown indoor air pollution reductions in homes using ICSs (such as the improved “Jiko” in Kenya, the “Plancha” in Guatemala or “Chula” in India) compared to homes using traditional open fires or rudimentary three-stone methods. One study highlighted a lower risk of ARI among children living in households using ICSs compared to children living in households using traditional fires. (Goldemberg J. 1996)

Concentrations of indoor air pollutants are thought to be affected by characteristics of the dwellings in which fires are burned. For example, a cross-sectional study in India found that in addition to fuel type, the strongest predictor of indoor air pollution in the living environment was having a kitchen separate from the living area as well as improved ventilation (Mehta et al. 2002). Similarly, a study in Guatemala found that larger burning environments reduce concentrations of pollutants (PM<sub>3.5</sub>) by every unit increase in volume (Albalak et al. 2001). A study in West Kenya showed that the provision of enlarged eaves (between roofs and tops of walls) and windows reduced PM<sub>3.5</sub> by 62 percent (Bruce et al. 2002).

Modifying household characteristics (such as providing separate kitchens, enlarging cooking environments and improving sources of ventilation) in poor contexts are expensive and therefore have been slow to be incorporated into development programs. In addition, there may be unintended consequences such as reduced privacy, increased security risk and negative effects on indoor temperatures (particularly in cold climates).

### **2.3 History of ICS**

In Nepal, more than 50 years ago, the idea of smokeless or improved stoves was introduced by a home economist of USAID/N and was demonstrated in several villages by the Village Development Service (Sharma, 1981). Due to the local and global crisis of fuel and shortage of firewood supply, people have become more anxious to

find solution to combat this crisis. For this reason more and more people are taking interest in Improved Cooking Stove to conserve firewood.

## **2.4 Historical Development of ICS in Nepalese Context**

With the introduction of the Indian Model Hyderabad and Magan chulo model during the early 1950s, the history of ICS development program in Nepal introduced. The agri-engineering workshop of the department of agriculture developed a mould with the help of which inexperienced and unskilled person could also use ICS. This approach was extended as a part of the village development service of the “Tribhuvan Gram Bikas Sewa”, which ended in the early 1960s and till the mid 1970s by the women’s training centre in disseminating the Lorena stove with further complementary effort from RECAST.

For the period of 1980s , interest and efforts were despised when the NPC includes ICS in an attempt to address the pressing fuel wood problem. The governments concern for fuel wood conservation was also reflected with the inclusion on ICS dissemination efforts an important component of FAO Assisted Community Forestry Development Project (CFDP) in 1981 ([www. aepcnepal.org](http://www.aepcnepal.org)). In early 90s, the development of mud bricks stoves models by RECAST which could be built in users households, by trained self employed workers with locally available material gave in the stove program a new look . ICS was promoted and disseminated by various organizations with and without subsidies, equal participation by users etc as a results, ICS became an important and integral component of development initiatives supported by a quite a number of programs , donor agencies and promoting organizations. The collective efforts of over 25 such organizations together promoted about 40,000 biomass stoves of various types in different districts of Nepal (CRT, 2000).

Different organization has initiated ICS promotion programs, e.g. FAO, USAID, UNSEDF, EEC, save the Children Fund etc. Since then about 86,000 are believed to have been disseminated in the hills and the terai. Similarly, during the development process of ICS, UNICEF supported the development of a Ceramic ICS named the “ New Nepal Chulo” and distributed these stoves through the Small Farmer Development Program (SFDP) in 1985. Government of Nepal accorded high priority

to increase ICS installation in the country in the 9<sup>th</sup> plan. From early 1999, for complement this, the national ICS program has been launched. The program was funded by Alternative Energy Promotion Centre (AEPC) of DANIDA and executed by Alternative Energy Promotion Centre of government through various implementing partners like Department of Women Development, CRT/N and other district level NGOs and CBOs. With the support from UNICEF the Ceramic cooking stoves, the new nepali chulo were also introduced through the ADB/N. New modification in stove for Tamang Chulo, cheap and readily available local material stoves dissemination have been started (CRT,1999).

## **2.5 Present Status of ICS**

There is no uniformity in the status of ICS used being quoted by different sources, however ICS programs have been promoted in rural community of Nepal since 1950s. Many INGOs, NGOs, CBOs, & research centers have involved in ICS dissemination in Nepal.

There are more than 90 local NGOs involved in the program and about 50000 Improved Cook Stoves are being disseminated every year. The national ICS program (1999-2006) by June 2006 had disseminated about 2,00,000 ICS serving the same number of households in 711 VDCs of 35 mid hill districts by the more than 2500 trained promoters out of which 50 percent are women. The total number of ICS installed during the period of July 2000- June 2006 by different organizations involved in the national ICS program has given below. The program has successfully demonstrated that the strategies adopted for ICS implementation were very convincing & the flexible approaches underlined above and implemented by the network of local partner NGOs integrating ICS in their ongoing program activities had been promising. This has been perceived as a strong platform for the commercialization of ICS in the rural households of Nepal.

**Table 2.1: ICS promotion status of NICSP till June 2006.**

<b>S.N.</b>	<b>Organizations</b>	<b>ICS Number</b>
1.	CRT/N*	126085
2.	CSD	15593
3.	RUCODES	17778
4.	Women Dev Division	2838
5.	DCRDC	22451
6.	NCDC	6419
7.	REDN/NEPAL	1020
8.	Sunder/Nepal	912
9.	NESPEC	753
10.	ICS installed in May June 2006	2199
Total		196048

*Source: Energy Sector Assistance Program (2006).*

\*ICS number for CRT taken till June 2006 where as for other until April 2006.

Apart from the actors involved in the national ICS program a few INGOs, NGOs, CBOs, donor organizations and local governing bodies have been promoting biomass stove during the period with varying strategies and in lesser scales compared to the national program . About 15-20 such organizations are promoting stoves on varying scale and together contribute about 3000 stoves per year. (CRT /N, 2001)

Thus the above combined efforts so far have disseminated about 325,000 ICS in the country until June 2006 including the 57000 promoted in late 70s, which is meager in number as more than two million wood burning household are there in the rural areas alone.(Thapa,2006).

## **2.6 Government Policy on Improved Cook Stove**

The NPC of Nepal for the first time included firewood problems were to be developed. The seventh five year plan (1985-90) targeted to distribute 160000 ICS, out of which 49, 938 were distributed by the forestry sector. (WECS, 1994).

The seventh plan envisaged an ambitious target to disseminate large number of ICS (CFDP 15,000 ICS & the TCFP 29,000 ICS). But it didn't specify an implementing agency for the dissemination. In 1991 and 1992, the forest sector distributed 7544 stoves.

The eight five year plan (1992-97) envisaged to distributed 2, 50,000 ICS, out of which 10,000 were planned for hilly region & the remaining 15, 0000 for terai (NPC, 1992) . Such hypothetical figure obviously became unrealistic as long as the distribution provision was not clearly specified and also there lack effective follow-up mechanism. The focus on number allowed programs appears successful even though many stoves were ultimately abandoned (NPC,6<sup>th</sup> ,7<sup>th</sup> & 8<sup>th</sup> plan) .

The aim of ninth plan was to install 2, 50,000 ICS in the country but only 51000 no. of ICS were installed. In the same way, though the aim was to provide training programs in 45 districts, the program could be launched in 39 districts only . Similarly, during the period of 10<sup>th</sup> five year plan government of Nepal had emphasized to install 2,50,000 no. of ICS in the rural area (NPC , 2003 ) .

Quite a number of institutions are involved in promotion and development of ICS with the objective of environment conservation and sustainable development of rural area by promoting such alternative energy technology. These institution have provided various kinds of support and have close relationship with NGOs and donors. No subsidy has been provided to ICS installations directly by government but many institutions which are involved in promotion and development of ICS have been providing technical and other needed support ( AEPC, 2006).

In order to make the subsidy Agreement, 2000 equitable, inclusive and effective, Renewable (rural) Energy subsidy Agreement, 2006 has been formulated to addressed need of time where, policy statement and subsidy type for ICS is given below :

No subsidy has been provided to house hold mud improved cook stoves in hills and mid hills of Nepal.50% subsidy is provided to improve cook stoves in High Mountain for cooking and space heating, as they are costly and un affordable but which is not more than NPR 2,500.Quite a number of institutions are involved in the development and dissemination of ICCs.These institutions have various kinds of supports. Close relationship contact with NGOs and donors will be established to make the direct and

indirect support to ICS made by them more effective. The important policies and strategies are enumerated below regarding promotions and dissemination of ICS in Nepal.

There has been an over emphasis on achieving, dissemination targets and less attention given on its use and user education. The programs are thus launched quantitatively but not qualitatively . This has completely precluded the formation of the self sustaining base of ICS users. Fuel woods conservation has been the major goal of ICS dissemination in Nepal. An improvement in domestic health through ICS dissemination has not yet been taken as a major concern of ICS program. Most ICS program lacked involvement of the local organizations and womens users. Women's refusal to accept and use the improved stoves have been blamed by energy planners for the failure of ICS programs. However, the blame could more correctly be placed on the failure of stove project planners who did not access social and economic factors and the users behaviours. The absence of large scale ICS awareness campaign and better communication and co ordination between government, NGOs private agency and research organization involved in promotion and development of ICS has remained a major problem. The problem of communication and co ordination is more severe at the district/village level.

In the past, the approach and strategies of various agencies promoting ICS distributions varied substantially. Because of these, there were expectations of free gift of ICS, free installation and maintenance and repaired. This has a negative impact upon potential interest group and NGO project advocating the self help approach. There is a low level of understanding and recognition from the government and policy makers regarding ICS users. Lack of support for technical back up, training and ICS dissemination under taken by NGOs/voluntary organizations is a major problem. The following organizations have involved in the dissemination and the development of Improved Cook Stoves in Nepal .

**Table 2.2: ICS related Organizations**

S.N.	Organization	No of ICS	Types of ICS
1.	Agricultural Development	8380 (not	Mud & iron type

	Bank	updated)	
2.	Alternative Energy Promotion Centre	5858	One, Two & Three pot hole
3.	Bagmati integrated Wasteshed Management Project	800	One & Two pot hole
4.	CARE Nepal	2003	Mud & metallic stove
5.	CEIC/Community Health Initiative Project	4000	Mud & top plated cast iron
6.	Center for energy and Environment	Approx 200	Two pot hole
7.	Center for Environment and Agricultural Policy Research Extension and Development	1557	Cast iron and chimney mod
8.	Centre for Rural Technology,Nepal	20,341	One ,Two & Three pot hole
9.	Centre for Self-help development	3586	Mud type and iron type
10.	Centre for social development and Environmental Production	50	Nepal ICS
11.	Centre for Social Mobilization	270	UNICEF model
12.	Department of Women Development	3900	Improved Tamang Stove
13.	Development project service center	2606	Improved Tamang Stove
14.	Environmental Camps for conservation Awareness	More than 100 in each project area	Different models as local requirements mostly improved

15.	Environmental Management Action Group	NA	NA
16.	Hills leasehold Forestry and Forage Development Project	1827	Tamang cook stove
17.	Holistic Development Service Centre(SANAGRA)	1343	NA
18.	Hostel Haines	NA	NA
19.	Human Welfare and Environment Protection Centre	2000(not updated)	Mud built smokeless stove
20.	Intermediated Technology Development Group	NA	Agro-processing stoves used for processing of “Lapsi Khuwa” and “Allo”
21.	King Mahendra Trust for Nature Conservation/ACAP	388	Mud and metallic stove
22.	MANUSHI	80	Discussion,observation,model show
23.	Mrigendra Samjhana Medical Trust	152	Improved Tamang Stove & metallic stove
24.	Nepal Red Cross Society	1252	Two pot hole with Chimney
25.	Research Centre for applied science and technology	459	Improved Tamang twin model, rest two pothole
26.	Rural Community Development Society	500	One & Two pot hole
27.	Samuhik Abhiyan	300	Mud brick with hole



28.	Shivapuri Integrated watershed development project	Around 200	Stove with iron grate and chimney less stoves , improved Tamang stove
29.	USC Canada	441(not updated)	Improved Tamang stove
30.	Women self Reliant Centre	210	NA
31.	Support Activities for Poor Producers of Nepal	1125	One,Two and Three Pot hole

*Source: CRT/N 2001*

## **2.7 Linked to Various Plants for Renewable Energy Technologies (RETs) Development**

During the seventh plans period (1987-1992) the positive role of alternative energy technologies for the fulfillment of energy needs for the rural people were organized by National Planning Commission. The 8<sup>th</sup> plan (1991-1997) introduced the need for a co-coordinating body for large scale promotion of AETs in Nepal ,AEPC was thus established to promote the AETs and act as the government coordinating body.

The 10<sup>th</sup> five years plan (2002-2007) emphasizes:

By improving and increasing the energy use competency and increasing the access of rural people by reducing the cost of development and installation sources of energy.

Supply energy for commercialization of the domestic needs and the professions of rural people by developing AETs best on local resources and tools.

Reducing dependency on imported energy sources and reducing negative environmental effects by the proper use of resources and tools of local energy.



## **CHAPTER III**

### **RESEARCH METHODOLOGY**

A system of broad principles or rules from which specific methods or procedures may be derived to interpret or solve different problems within the scope of a particular discipline. A methodology is not a formula but a set of practices. It is the backbone of the study. So; it needs to be well defined to conduct the study. That's why in this study the following methodology has been adopted to fulfill the objectives.

#### **3.1 Research Design**

The study focuses on investigation of positive as well as negative impact of ICS in the community followed by descriptive as well as analytical research design. The study also finds the trend of fire wood consumption, utility study of ICS, health impact on women and saving a fuel wood in comparison to traditional stoves and its affordability. The descriptive method was used for the qualitative data obtained during the study. Analysis of the data was made by generating the tables of averages and percentage.

#### **3.2 Rationale on the Selection of Study Area**

The study has been conducted at ward No. 3-of Thanapati VDC of Nuwakot district. The village community is comprised up of different ethnic and socio-economically disadvantage groups. The research had been done among the Improved Cooking Stoves users of the village. The main purpose of the study is to dig out the impact of ICS technology and its performance in such topographically constraint and socio-culturally diversified area.

ICS, an emerging demand as a technology of alternative energy source, is being flourished in Thanapati VDC of Nuwakot District. So the Present study has been carried out in Thanapati VDC.

The reason to select Thanapati VDC as a study site is that the researcher being the neighbor inhabitant of the area. Secondly, the researcher is familiar with local people.

Therefore, by selection of this VDC, it is believed that more accurate information could be collected during study and also study could be accomplished easily.

### **3.3 Sampling Procedure**

The research has been conducted among the users of ICS technology at Thapagaon village of Thanapati VDC ward no. 3 out of total households 200 , 40 households (20%) were selected as sample for the study which is considered as a univers for the sampling procedure . Thus the simple random sampling procedure has been adopted to select the sample of ICS installed households.

### **3.4 Source of Data**

To meet the objectives of the study, primary as well as secondary data has been used.

#### **3.4.1 Primary Data**

Through the structured questionnaire methods the primary data has been collected. Questionnaire is the main tool of information of field survey.

#### **3.4.2 Secondary Data**

Secondary data is data collected by someone other than the user. Data collected by government and non-government offices in their different studies has served as secondary data in this study. The unpublished and published records of AEPC, ADB/N, REDP,CRT /N,NPC and former dissertations had been the source of secondary data. Besides, different journals magazines newspapers and different experts and consultants of the related field also served as partial secondary source of data.

### **3.5 Techniques of Data Collection**

To generate the primary data different techniques have been used which are given below.

### **3.5.1 Household Survey**

To collect the primary data, household survey was conducted by using both structured and unstructured questionnaire, and were filled up by the researcher herself, asking answer from the respondents. The respondents were the female member of the sampling households. A structured questionnaire schedule had been developed with an attempt to bring out the different status of respondent's attitudes, beliefs, perceptions and concepts upon the utilization of Improved Cook Stoves and improvement of their livelihood, as demographic and socio-economic information, status of the alternative energy technology (ICS), and its impact on rural community especially the women of the study area.

### **3.5.2 Key Informant Interview**

An unstructured interview becomes important to be clear when contradiction and confusing comes at the time of data collection and gathering information from the different respondents. So the unstructured interview has also been done with local experts' social mobilize and local promoters of ICS who are familiar with ICS.

### **3.5.3 Observation**

The researcher had observed and recorded the performance of ICS and activities of the family members while interviewing the respondents and observed whether the trend of alternative energy technology use is serving in the right path, improving level of energy consumption of the study area.

### **3.5.4 Focus Group Discussion**

FGD had been used to take out the more appropriate information and for the comparative study of concept and attitude of the respondents of different categories. For example, social mobilizers, leaders, youths, real beneficiaries and service holder had been recorded.

### **3.5.5. Case Study**

The study has been the comparative study between those respondents who possessed the maximum energy consumption and respondents who possesses the minimum energy consumption of total alternative energy consumption of the study area.

### **3.6 Tools of Data Collection**

To collect the primary data different tools were used which are following:

#### **3.6.1 Questionnaire/Check List**

Both the structured and unstructured questionnaires have been used to generate the realistic and accurate data from the respondents of the study area. Checklist was prepared to be clear during field survey.

### **3.7 Data Presentation and Analysis**

To make the collected data meaningful and to meet the objectives of the study the collected data are analyzed. Analysis of the data is not just of statistical method it is an approach and a way of sinking. Edited data are coded, interrelated and analyzed to meet the objectives of the study. Data were presented using frequency, percentage, average, and ratio.

## CHAPTER IV

### BACKGROUND TO THE STUDY AREA

This chapter mostly consists of the general introduction of the study area which includes area, population. Economic activities, educational status, transportation, climate, communication, energy use and water supply facility of the VDC.

#### 4.1. Field Area: Thanapati VDC

Thanapati VDC lies at northeast part of the district. The peripheral VDCs of this VDC are Thansing VDC in the North and Sunkhani VDC in the East, Simle in the West. The VDC spread from north to east . The VDC is surrounded by greeny attracted forest area named Sauraha Pakha, rivers named Ghatte khola.chhahare khola and one one of the productive areas of the Nuwakot district. It has nine wards and 13.90 km<sup>2</sup> areas.

North Latitude	- 27° , 48' 45'' - 27° , 51' 55''		
East Longitude	- 85° , 16' , 7.25'' - 85° , 18' , 45''		
Maximum Height	- 620m		
Minimum Height	- 2305m		
Distance from Headquarter	- 5 mile		
Way of Access	- Kachhi Road		
Total Population	- 3384		
Literacy Rate	Male	Female	Total
	53.6	39.4	46%

*Source: Nuwakot District Profile 2063*

**Table : 4.1 : Population by 5 years of age group of Thanapati VDC**

S.N	Age Group	Population	Percent
1.	0-4	150	4.43
2.	5-9	279	8.24
3.	10-14	261	7.71
4.	15-19	315	9.30
5.	20-24	200	5.91
6.	25-29	200	5.91
7.	30-34	211	6.23
8.	35-39	260	7.68
9.	40-44	274	8.09
10.	45-49	150	4.43
11.	50-54	150	4.43
12.	55-59	280	8.27
13.	60-64	168	4.96
14.	65-69	211	6.23
15.	70-74	170	5.02
16.	70+Above	105	3.10
Total			

*Source: CBS, 2001*

### **Population**

The majority of the population is consisting of Chhetries and Brahmins. Other different groups after Chhtries and Brahmisa are Damai, Tamangs, Newar, Gharti & Kami in this VDC.

### **4.2 Economic Characteristics of Thanapati VDC**

#### **Economy**

The agriculture land and agricultural production is the economic backbone of this VDC. People range from small farmers with small land holdings. Livestock rearing, poltry farming and Horticulture is also seen in the VDC as a source of economy.



Another source of income is milk production and selling to local market. From five years Ginger farming is being another source of income in this VDC. There is a temple named as Thanapati Mai in the VDC which is considered as one of the powerful goddess in the district .People from different neighboring districts visit the temple during Dashain and Dhannya Purnima . In Dhannya Purnima, people comes from different places to flame “Maadi” especially, Thapaliya Famalies and other Pandey , Silwal,etc. Therefore, religious tourism can also be a source of income for the VDC in future.

### **Educational Institute**

There is one Higher Secondary in Ward No. 7 of this VDC. Each ward has a primary school. There are still the problems of infrastructures and require teachers in each school. The students has not go to the headquarter after completion of Secondary level for further study.

<b>Pre-Primary</b>	<b>Primary</b>	<b>Lower Secondary</b>	<b>Secondary</b>	<b>Higher Secondary</b>	<b>Total</b>
0	5	0	1	1	7

*Source: CBS, 2001*

### **Communication**

There was not good communication facility in the past but now day’s locals are operating Co - Division Multiple Access (CDMA) and cell phones. Radio and T.V are run and three local F.M. radio has started from two years in the district which is a good source of information for local people.

### **Transportation**

There is provision of road access to all the VDCs of the district. It is difficult to get vehicles to get to the VDC.The road from Kathmandu to Thanapati VDC which is joined to district headquarter only graveled .It’s processing for black topped.

## Climate

The temperature of the VDC is neither too hot nor too cold rather it has temperate climate. The monsoon starts from Jestha and ends in Aswin . Th average rainfall ranges from 1700 mm to 2200 mm.

## Energy

Besides electricity, solar energy is also increasingly used in these days some of the households have installed bio gas plant and some used kerosene. The train of installation of ICS is seen in increasing rate in the VDC.

## Water Supply

There is a facility of piped water supply in this VDC. Most of the households have to go up to community tap to fetch water and only few have personal tap. The water supply program was launched by the project named HEIFER / CARDSON .

## 4.2 Population Composition by Caste and Ethnicity

S.N.	Caste	Population	Percent
1.	Chhetri	38738	13.42
2.	Brahman- hill	59729	20.70
3.	Kami	8020	2.78
4.	Damai	3756	1.30
5.	Rai	95659	3.31
6.	Magar	6475	2.24
7.	Sarki	4066	1.40
8.	Tamang	111112	38.51
9.	Tharu	458	6.15
10.	Newar	21927	7.6
11.	Thakuri	1004	0.34
12.	Muslim	386	0.13
13.	Yadav	80	0.02
14.	Limbu	16	0.005

*Source: CBS, 2001*

### **4.3 Population by Religion of Thanapati VDC**

S.N.	Religion	Population	Percent
1.	Hindu	2232	65.95
2.	Bauddha	1151	34.01
3.	Others	1	0.02
4.	Total	3384	100

*Source : CBS ,2001*

### **4.3 Health Status of Women**

According to the CBS 2001, life expectation of female is lower than that of male in Nepal due to poorer health status and higher honesty in females. Despite of enough education and tradition of early marriage, most of women spent immensity of their life in bearing and rearing children. Likewise, illegal abortion assumed to account for a sustainable number of maternal deaths.

In Thanapati VDC, about two third parts of the total households work is done by women alone, which has been proved during the field visit of the researchers. Because of their busy life, they have not enough time to give attention towards the health and nutritional sector. That's why the health status of women in Thanapati VDC is not good enough in comparison to the male.

### **4.4 Problems of the Women in Thanapati VDC**

In this VDC, Because of the low economic status, at least one male has been outside the family or country from each household. The male member usually go to earn money in foreign countries especially gulf. While there is no male member in the family, the working load of women has also been increasing automatically. Not only this much, they were also playing the role of decision maker, solving the all household problems along with bearing and rearing the children.

### **4.5 Access to Energy**

Thanapati is not enough developed VDC and the villagers have not access and affordability to use commercial fuels for cooking. So fuel wood is the major energy

source of this VDC, which is collected from nearby forest and sometimes from community forest too. The number of villagers who were using bio-gas as an alternative energy source for cooking is very low in quantity.

#### **4.6 Promotional Activities of ICS**

Nowadays some ICS experts have been personally contributing in the development and promotion of ICS. Social mobilizers have also been giving hand to hand to people of Thanapati VDC in the distribution of ICS. According to the field survey more than 668 were installed in the VDC and among them there are more than 265 ICS has been disseminated in ward no 1 and 2 only, most of them working efficiently.

In different district ICS was distributed for example first the ICS was distributed by CRT/N through its regional office in Syangja district which was continued up to 2063 B.S. But now a days there are different organizations involved in the promotion of ICS such as RCHDC ( Rural and Community Health Development Centre) through REDA( Rural Economic Development Association) having its regional office in Palpa district. Most of the stoves were successful and effective but some of them were unsuccessful and inefficient.

List of the local organizations involved in the promotion and development of ICS in Nuwakot District.

1. CARDSN
2. Surya Daya Samajik Club
3. Samudayak Bikash Kosh
4. Panchakanya Mahila Samajika Sastha.
5. Ramche Mahila Samajik Sastha.

# CHAPTER V

## PRESENTATION AND ANALYSIS OF DATA

This chapter basically consist of the analysis of the data collected from the field survey , which are processed further to access the require impact evaluation.

### 5.1 Socio-Economic characteristics ICS User Groups

Family size, Ethnicity/Caste, Composition and land holding were the main variables considered in the field study.

#### 5.1.1 Family Size

Distribution of the households according to family size is shown in the table 5.1 below.

**Table 5.1 Distribution of Family Size**

S.N.	Family Size	No. of Households	Percentage
1	Small size(Up to 4 persons)	10	25
2	Medium(5-10 Persons)	23	67.5
3	Large (above 8 persons)	7	17.5
	Total	40	100

*Source: Field Survey, 2011*

The above table 5.1 shows that the maximum households had medium sized family. The minimum family size was four persons and maximum family size was 16 persons.

#### 5.1.2 Ethnicity/Caste

Ethnicity /Caste composition of the respondents show that half of the respondents were Chhetris, followed by Brahmans 35, Sharki & Damai 5/5 , Kami2.5 & Others 7.5.

**Table 5.2. Ethnicity/Caste of Households**

S.N	Ethnicity/Caste	No. of Households	Percentage
1	Chhetris	18	45
2	Brahmans	14	35
3	Kami	1	2.5
4	Sarki	2	5
5	Damai	2	5
6.	Others	3	7.5
	Total	40	100

*Source: Field Survey, 2011*

**Pie Chart-2: Ethnicity/Caste**

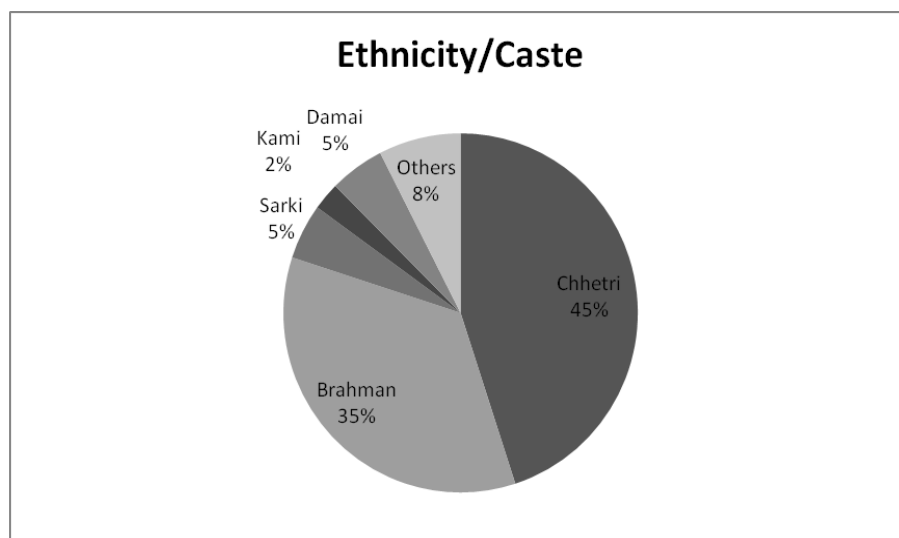

*Source: Field Survey, 2011*

This figure shows that Chhetri are predominant in installing the Improved Cooking Stoves.

### **5.1.3 Age Group Population**

The different age group population is tabulated in table 5.3 below.

**Table 5.3: Age Group Population**

S.N	Age Range	No. of Persons			No. of Households	Percentage
		Male	Female	Total		
1	1-5	9	7	16	13	6.32
2.	5-10	10	18	28	28	11.06
3.	10-20	27	29	56	26	22.13
4.	20-30	28	31	59	29	23.32
5.	30-40	12	17	29	21	11.46
6.	40-50	20	15	35	22	13.03
7	50-60	6	7	13	12	5.13
8.	60 +	7	10	17	10	6.71

*Source: Field Survey, 2011*

The above table 5.3 shows that the maximum households had age group of 20-30.

#### **5.1.4 Educational Status**

Education plays vital role in the overall development of any community. The following table 5.4 shows the educational status of the surveyed area.

**Table: 5.4. Educational Status of the Family**

S.N.	Educational Status	No.of Persons			No. of Households	Percentage
		Male	Female	Total		
1.	I.A.& Above	27	11	38	21	15.05
2.	S.L.C.	17	17	34	22	13.43
3.	6-10	26	42	68	29	26.87
4.	1-5	26	23	49	31	19.36
5.	Literate	17	10	27	19	10.67
6.	Illiterate	6	31	37	27	14.26
	Total	119	134	253		100

*Source: Field Survey, 2011*

**Pie Chart-3: Educational Status**

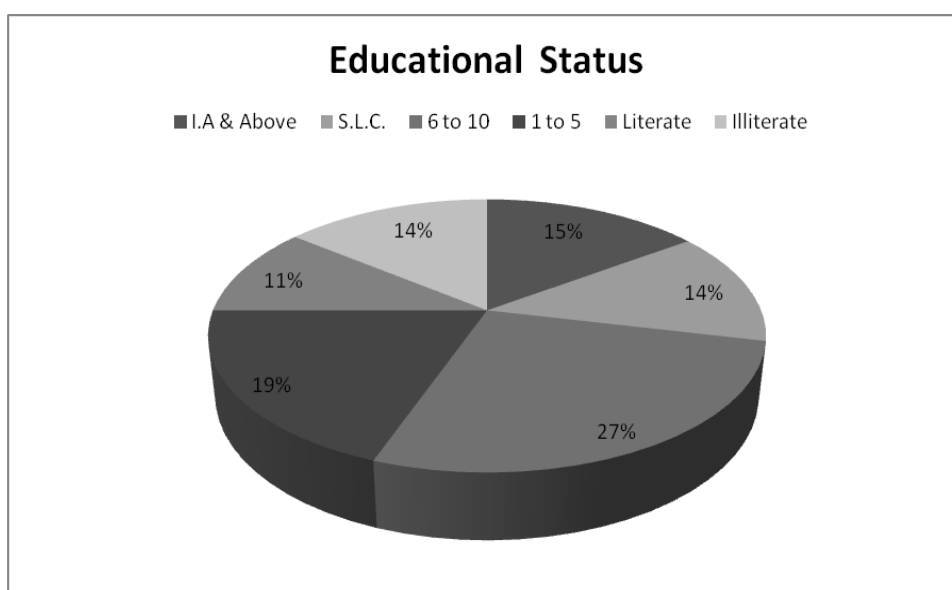

*Source: Field Survey, 2011*

The above table 5.4 shows that the maximum people belongs to 6-10 class .

### 5.1.5 Landholding

.....

### 5.1.6 Occupation of the Family Members

The respondents had followed the various occupations to sustain their life. Following table 5.6 shows the occupational status of the family members .

**Table 5.6: Occupation of the Family Members**

S.N.	Occupation	Male	Female	Total	No. Of Households	Percentage
1.	Farming	30	50	80	21	30.07
2.	Student	47	34	81	38	30.4
3.	Teaching	8	3	11	10	4.13
4.	Business	20	5	25	15	9.39



5.	NGO,INGO	30	25	55	25	20.6
6.	Others	8	6	14	9	5.26
	Total			266		100

Source: Field Survey, 2011

**Pie Chart-4: Occupation**

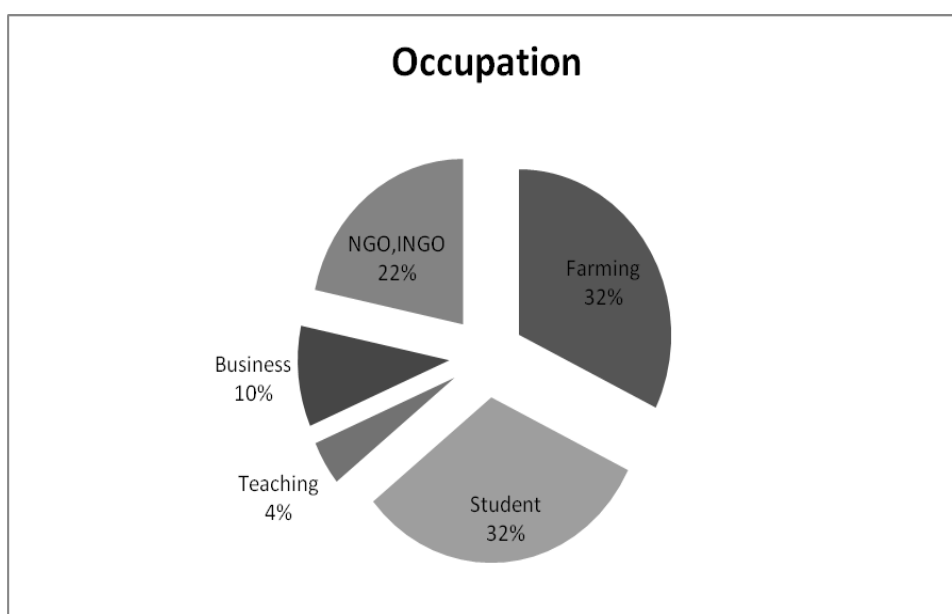

Source: Field Survey, 2011

The above table 5.6 shows that the maximum households were farmers (30.07%) and minimum were teachers(4.13%).

### 5.1.7 Main Source of Income

Though agriculture is the main source of income of the respondents, there were also other sources. Main source of family income is divided into four categories as Agriculture, Service, Business and Labour wage.

**Table 5.7. Main Source of Income**

S.N.	Source of Income	No. Of Households	Percentage
1.	Agriculture	31	79

2.	Service	2	4
3.	Business	4	10
4.	Labour wage	3	7
	Total	40	100

Source : Field Survey 2011

**Pie Chart-5: Source of Income**

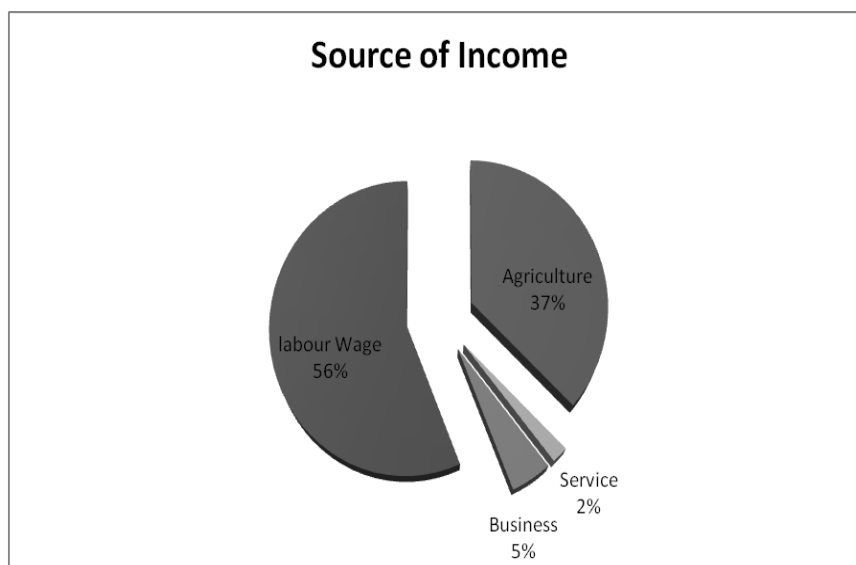

Source: Field Survey, 2011

According to the above figure agriculture is the main source of income of the respondents. The lowest percentage of the respondents was involved in civil service. Similarly, (7%) of the respondents were dependents on labour works.

### 5.1.8 Total Annual Income of Households

Survey of the total annual income , shows that the maximum households (30%) had the annual income between 90 - 100 thousand.

**Table : 5.8 Annual Income**

S.N.	Annual Income	No. Of Households	Percentage
1.	Less than 30 thousand	5	12.5
2.	30-50 thousand	7	17.5

3.	50-70 thousand	5	12.5
4.	70-90 thousand	8	20
5.	90-100 thousand	12	30
6.	Above 1 Lakh	3	7.5
	Total	40	100

Source: Field Survey, 2011

**Pie Chart-6: Annual Income**

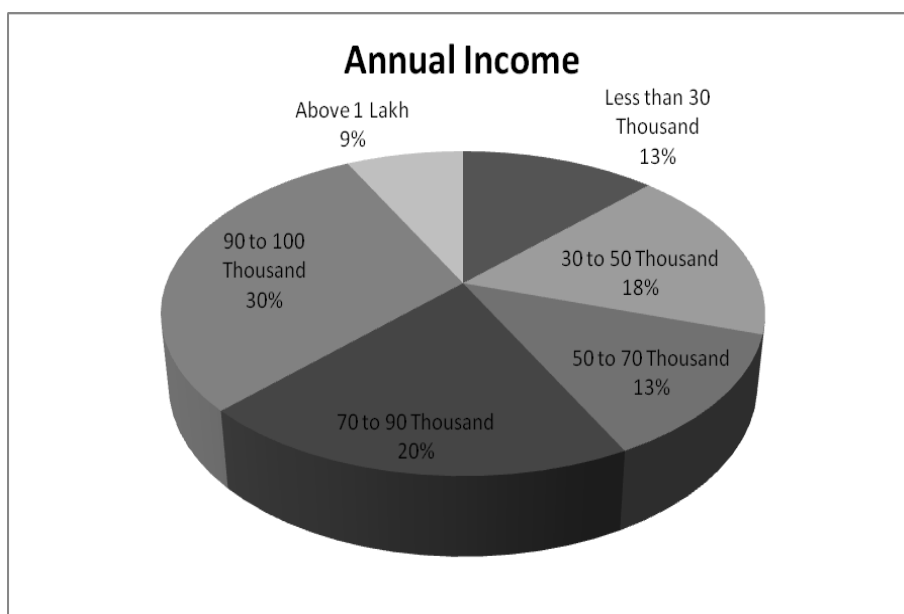

Source: Field Survey, 2011

The above table 5.8 shows that the maximum people belongs to 90-100 (30%) annual income .

### 5.1.9 Dependability or Agro Products

The VDC has fertile soil and so it is one of the productive areas of the Nuwakot District. The following table 5.9 shows months of sustained form Agro products.

**Table 5.9 Months Of Sustained**

S.N.	Months of Sustained	No. Of Households	Percentage
1.	1-3 months	0	0
2.	3-6 months	1	2.5

3.	6-9 months	1	2.5
4.	9-12 months	15	37.5
5.	12 months and more	23	57.5
	Total	40	100

*Source: Field Survey, 2011*

The above table 5.9 shows that 57.5 households had sustained 12 months and more. While 2.5% households and the same percentage households had sustained to 3-6 months and 6-9 months respectively from the agro products.

### **5.1.10 Types of House**

The respondents had kacchi house with stone thatched roof and kacchi with zink or stone roof.

**Table 5.10 Types of House**

S.N.	House Type	Respondents	Percentage
1.	Kacchi with Thatched roof	10	25
2.	Kacchi with zink or stone roof	30	75
	Total	40	100

*Source: Field Survey 2011*

According to the table 5.10, most of the respondents had kacchi house with stone and roof they possessed about 75% and remaining 25% respondents had houses with kacchi wall and thatched roof.

## **5.2 Knowledge on Improved Cooking Stove**

### **5.2.1 Source of Information on ICS**

The initial source of information was the respective ICS promoters of ICS promotion organizations.

**Table 5.11: Source of Information**

S.N.	Source of Information	No. Of Household	Percentage
1.	Neighbour	10	25

2.	Local Promoter	25	62.5
3.	Radio/ T V	4	10
4.	Friends	1	2.5
5.	Others	0	0
	Total	40	100

*Source: Field Survey, 2011*

The above table 5.11 shows that local promoters (62.5) served as the chief source of information about ICS.

### **5.2.2 Date of Installation**

The installation of ICS has been increasing in ward no.3 VDC. The date of installation is shown following table.

**Table 5.12: Date of Installation**

<b>S.N.</b>	<b>Date Installed</b>	<b>No of Households</b>	<b>Percentage</b>
1.	2062	3	7.5
2.	2063	7	17.7
3.	2064	5	12.5
4.	2065	8	20
5.	2066	7	17.7
6.	2067	10	25
	Total	40	100

*Source: Field Survey, 2011*

According to the above table 5.12 the maximum households (25%) had installed ICS in 2067 B.S.

### **5.2.3 Types of ICS Used**

All of the respondents were using two pot hole with chimney.

### **5.2.4 Reason for ICS Installation**

There is community forestry nearby the village and the people do not have their own private forests. As fuel wood is their major source of energy for cooking they have been facing the problem of scarcity of the resource because the forest is not always open for them. After the awareness programs in different periods the residents of the village were increased to install such a fuel saving cook stove.

### 5.2.5 Main Benefited Group

The ICS installation benefited all the members of families. However the following table 5.13 shows the main benefited groups of the families.

**Table 5.13 Main Benefited Group**

S.N.	Main Benefited Group	No of Households	Percentage
1.	10-20 Years	4	10
2.	20-40 Years	10	25
3.	40-60 Years	20	50
4	Above 60 Years	6	15
	Total	40	100

*Source: Field Survey, 2011*

According to the table 5.13 40-60 years group(50%) were the main benefited groups from the system of installation.

## 5.3 Energy Technology:Source of Cooking

### 5.3.1 Source of Cooking

All the households had used in fuel wood as the chief source of cooking before the installation of the system.

### 5.3.2 Purpose of ICS Use

Generally Improved Cooking Stoves were used for cooking except that very few of Thanapati VDC were using ICS for space heating, and to prepare food for their livestock.

**Table 5.14 Purpose of ICS Use**

S.N.	Purposes	Respondents	Percentage
1.	Cooking daily meals	40	100
2.	Space heating	3	7.5
3.	Feed for livestock	4	10
4	To run small scale business	1	2.5
	Total	40	100

*Source: Field Survey, 2011*

As mentioned in above table all the respondents were using ICS for cooking .Similarly, 10% respondents were using stoves to prepare livestock food and 7.5% for space heating and only 2.5% were found to have used ICS for commercial purpose.

### **5.3.3 Utility of the System**

The survey showed that 100% households mainly used it for cooking meal and breakfast. The cooking hours range from 2-4 Hours per day. Some of the respondents said that they used ICS for other purposes except cooking meal and breakfast such as space heating, to feed animals and to run small business. But ,some of them also said that it is quite harder for them to prepare huge amount of food during gatherings . Some of the respondents with joint family replied that it has become quite difficult for them to run ICS during winter because there is a system of “ Aghenu” ( An open place where fire is burnt in a tripod and all the members of the family sit around the tripod so that they could get the same heat all around) Where the elder members, childrens and also male members of the family intend to be in the kitchen to get warmth. Therefore, they have to run two stoves improved as well as Aghenu at the same time and some times Aghenu only. That’s why it becomes quite difficult to run ICS throughout the year. On the other hand, some of the respondents found it very usefull

during winter too as they would place a box of tin above the first burner after finishing cooking which could work as a heater to heat the room.



### 5.3.4 Involvement of Family Members in Collecting Fire Wood

**Table 5.15 : Involvement of Family Members in Collecting Fire wood**

S.N.	Collected by	Respondents	Percentage
1.	Female	18	45
2.	Male	10	25
3.	Both	10	25
4	Children	2	5
	Total	40	100

*Source:Field Survey,2011*

Above table shows most of the respondents replied about 45% female usually go for collection of firewood. Similarly, 25% male collect wood, both 25% of respondents collected firewood and 5% children also collect firewood. Most of the female replied that “ the burden of firewood collection have been lessened after installation of ICS “.

### 5.3.5 Time Saving

It was regular phenomenon in village that people have to walk along way to collect and bring fuelwood. The farther the collection center is more the time is consumed. Requirement of less fuelwood after ICS installation has definitely saved such time. In addition, the food in ICS is cooked faster than in traditional stoves. Hence, time is saved from two activities i.e from fuelwood collection and from cooking activities.

**Table 5.16 : Time Saving**

S.N.	Time	Respondents	Percentage
1.	More time	4	10
2.	Same time	6	15
3.	Less time	30	75
	Total	40	100

*Source:Field Survey,2011*

In this table more than 75% of the respondents have reported that time is saved after ICS installation . Similarly 15% reported same time and 10% reported it takes more time than traditional stoves.

### 5.3.6 Activities Carried Out During Saved Time

Majority of the time saved is used in working in the field . 40% of the respondents utilized the saved time in field work followed by cleaning house.

**Table 5.17 Activities Carried Out During Saved Time**

S.N.	Activities	Households	Percentage
1.	Field Work	16	40
2.	Cleaning house	9	22.5
3.	Caring aged and children	4	10
4.	Other income activities	5	12.5
5.	Teaching Children	3	7.5
6.	Radio/TV	2	5
7.	Social work	1	2.5
	Total	40	100

*Source: Field Survey, 2011*

**Column.1- Activities Carried Out During Saved Time**

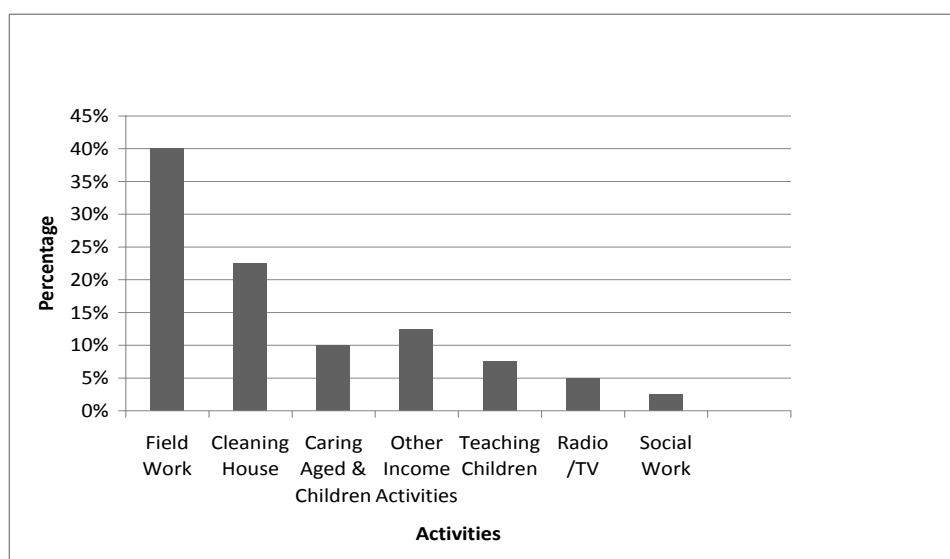

Source: Field Survey, 2011

In this column, percentage is in horizontal and activities are shown in vertical line. According to this column the highest percentage is in field work and lowest is in social work. Other income generating activities are alcohol preparation Namlo & Doko making, knitting and goat raising poultry farming etc.

### 5.3.7 Problems of Traditional Stove

**Table 5.18 Problems of Traditional Stove**

S.N.	Problems	Respondents	Percentage
1.	Smokey Environment	40	100
2.	More Consumption of Fuel wood	38	95
3.	Time Consuming	40	100
4.	Health Problems	36	90

Source: Field Survey, 2011

According to the above table, most of the respondents about 100% said that the main problem of traditional stove was smokey environment and was time consuming as well. Likewise, 95% respondents replied that more consumption of fuel wood was another main problem of traditional stoves 90% agreed that the traditional stove caused health problems.

### 5.3.8 Health Problems

The smokeless environment definitely helps to reduce smoke related diseases. But, traditional stoves couldn't get out from it.

**Table 5.19 Health Problems by Traditional Stoves**

S.N.	Problems	No. Of Households	Percentage
1.	Eye Tears	12	30
2.	Eye Irritation	10	23
3.	Nose Running	3	7.5
4.	Headache	4	10
5.	Throat Irritation	2	5
6.	Eye Swelling	3	7.5
7.	Chest Pain	3	7.5
8.	Asthma	2	5
9.	TB	1	2.5
	Total	40	100

*Source: Field Survey, 2011*

**Column-2: Health Problems By Traditional Stoves**

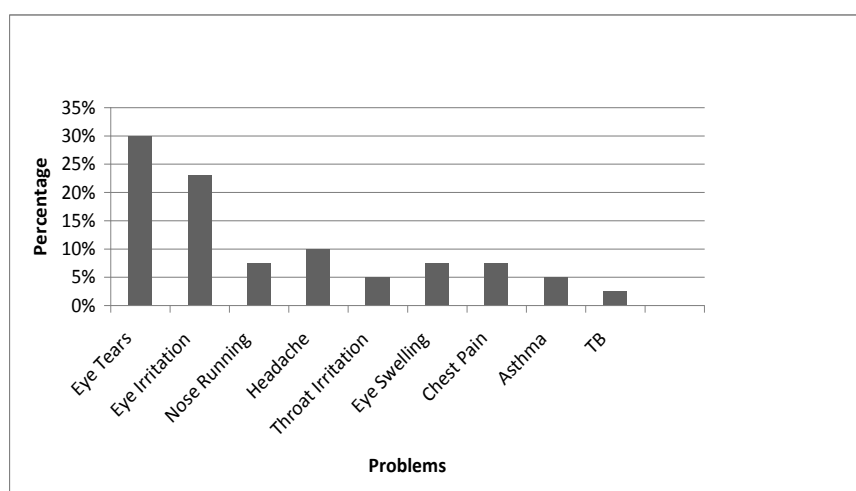

*Source: Field Survey, 2011*

Most of the respondents had ophthalmic problems as 30% had eye tear problem and 23% complained about eye irritation. However, one 1% had complained about TB.

### 5.3.9 Consumption of Fuel Wood

The consumption of fuel wood varied according to family sizes. The following table 5.18 shows the quantity of fuel wood consumption before installation of ICS.

**Table 5.20 Consumption of Fuel Wood in Traditional Stoves**

<b>S.N.</b>	<b>Consumption of Fuel wood monthly (Bhari)</b>	<b>No. Of Households</b>	<b>Percentage</b>
1.	3-4	18	45
2.	5-6	13	32.5
3.	7-8	9	22.5
4.	Total	40	100

*Source: Field Survey, 2011*

The above table 5.20 shows that maximum households 45% had used 3-4 bhari of fuel wood monthly before installation of the system and 22.5% had used upto 7-8 bhari of fuel wood.

### **5.3.10 Condition of Sufficiency of Fuel Wood in TCS**

Majority of the respondents were suffering from time and fuel consuming traditional Stove. The condition was before the installation of the system.

**Table 5.21: Condition of Sufficiency**

<b>S.N.</b>	<b>Sufficiency</b>	<b>No. Of Households</b>	<b>Percentage</b>
1	Insufficient	32	80
2	To some extent	8	20
3	Sufficient	0	0
	Total	40	100

*Source: Field Survey, 2011*

Thus, the above table 5.21 shows that the 80% of the households experienced the traditional stoves as insufficient and more time consuming.

**Table 5.22 Consumption of fuel wood in ICS**

S.N.	Consumption of Fuel wood monthly (Bhari)	No. Of Households	Percentsge
1	2-3	21	52.5
2	4-5	14	35
3	6-7	5	12.5
	Total	40	100

*Source: Field Survey, 2011*

The above table shows that there has been significant reduction in the fuel consumption after the installation of the system. Maximum households(52.5%)had used 2-3 Bhari of fuel wood monthly after the installation of the system and (12.5%) had used 6-7 Bhari of fuel wood.

*(Note:In a Bhari there is nearly 35kg -50 kg of firewood)*

### **5.3.11 Difference in Consumption of Fuel wood before and after the installation of the System**

There was drastic reduction in consumption of fuel wood after the installation of the system. The maximum households replied that the consumption of fuelwood was greatly reduce .

### **5.3.12 Maintenance and Repair**

Almost 60% of households had replied that they clean the ICS monthly and 25% said that they can clean chimney in every 2 months and rest of the respondents replied that they can clean when any problem appears in the stove.

## **5.4 Environmental Aspects**

### **5.4.1 Smoke Free Environment**

All respondents of the households agreed that they lived in smoke free environment after installation of ICS.

## 5.4.2 Condition of Household Environment

The households experienced the improvement of surrounding environment th following table 5.23 shows the condition of households environment.

**Table 5.23 Condition of Household Environment**

<b>S.N.</b>	<b>Condition of H.H Environment</b>	<b>No. Of Households</b>	<b>Percentage</b>
1.	Improved kitchen management	35	87.5
2.	Less Smoke Emmission	38	95
3.	Time Saving	40	100
4.	Less Fuel wood Consumption	40	100

*Source: Field Survey,2011*

The above table 5.23 shows that the maximum households experienced very good environmental condition of the surrounding . Experienced less smoke emmission in the kitchen which was helped the kitchen environment to be smoke free and healthy. All of the respondents replied that it is time saving and has less fuel wood consumption compare to traditional cook stoves.

## 5.4.3 Environmental Conservation and Social Development

All respondents said that th system installation helped in environmental conservation and social development by reducing indoor air pollution.

## 5.5 Economic Aspects

### 5.5.1 Benefit of ICS

The maximum households replied that they increased their household activities, have more time for study hours of the children, women have more time toengage in other productive sectors , thus the social and economic activities got widen after the installation of ICS. 2.5% replied that they have been using ICS to run tea shop in the village which has inhance their economic activities .

## 5.5.2 Social and Economic Activities

More than 50% respondents had involved in farming so that they had left little time to be free. 55% respondents had involved in social and economic activities , 25% respondents helped in study of their children and remaining have leisure time to have rest. The educated person also have time to read newspaper for utilizing their free time.

## 5.5.3 Usefulness the System

The following table: 5.24 shows the usefulness of the systems.

**Table 5.24 Usefulness of ICS**

S.N.	Usefulness of System	No. Of Households	Percentage
1.	Very Useful	30	75
2.	Useful	10	25
3.	Not Usefull	0	0
4.	Total	40	100

*Source: Field Survey, 2011*

The above table 5.24 shows that the maximum respondents said that the system was very useful for the households.

## 5.5.4 Health Expenditure

All households had not exact idea on the reduction of health expenditure. However, all respondents agreed that it has positive long term effect for their life longevity.

## 5.6 Operation and Maintenance

### 5.6.1 Problems

The following table 5.25 shows the various problems faced after the installation of the system.



**Table 5.25 Problems Seen in ICS**

<b>S.N.</b>	<b>Problems</b>	<b>No. Of Households</b>	<b>Percentage</b>
1.	Operational & Maintenance	2	5
2.	Problem of appropriate size	3	7.5
3.	Space heating during winter	5	12.5
4.	Others(No problems)	30	75
	Total	40	100

*Source: Field Survey, 2011*

The study had shown that the maximum households 75% had not any problems in their ICS .5% households had operational and maintenance problem while 12.5% households experienced the problem of inappropriate size and space heating during cold.

### **5.6.2 Sufficiency of Cooking**

The maximum households had experienced cooking sufficiency. According to them the cooking insufficiency was frequent pro during winter season. A HH had experienced the frequent problem of backfire as the chimney was not fit at right direction.

### **5.6.3 Training on Improved Cook Stove(ICS) Technology**

The 40% users got simple operational and maintenance training from their respective promoter and remaining 60% were untrained.

### **5.6.4 Satisfaction with the System Installation**

All the users were satisfied of the system installation. According to them the system installation reduced the burden of collecting fuel wood, buying kerosene and other fuels such as LPG gas, women get more leisure time which could be spent for caring of children, kitchen management, household activities and other productive activities as well. In the same way children have got more time for study. Among the satisfactory people , most of the population was of female.

The 84.5% Households were satisfied with the promoter and promoting organizations. 5% Households were unsatisfied because there was no provision of frequently follow up mechanism and needed trainings.

## **5.7 User's Perception and Suggestion**

### **5.7.1 Perception**

All of the respondents had positive opinion toward Improved Cook Stove (ICS) installation. They were very entertained by using the alternative energy technology. The people marked difference in saving time and improvement in health condition and healthy indoor environment.

### **5.7.2 Critical Suggestion**

All the respondents had advised that everyone should install the system in remote areas where there is problem of scarcity of fuel wood and imported fuels are not accessible and affordable. The main critical suggestion receive as:

- a. It is far better than Traditional Cook Stove, helpful especially for women and children.
- b. It reduce indoor air pollution and health hazard but subsidy should be provided by concerned agencies.
- c. No fear of children to fall in fire and no more coarse hands due to cleaner utensils.
- d. No more soot in the house and managed kitchen.
- e. It should be installed by determining appropriate size for different size of family.
- f. It should be made completely free for the very poor people who can not afford and make access to all.
- g. Concerned sector should provide appropriate training plus awareness programmes to all the users and non users.
- h. The chimney should be fixed slant at the direction where the frequency of wind flow is minimal to be safe from the problem of backfire.

### **5.7.3 Advice for the Better Operation of the System**

- a. The promoter should fit the chimney at the direction where flow of wind doesn't have adverse impact on air pass out.
- b. The chimney should be cleaned bimonthly and should be placed at suitable direction to be safe from the problem of backfire.
- c. Size of stove should be according to the family size.
- d. Rigorous refresher trainings should be conducted for promoters and users of ICS.

## CHAPTER VI

### FINDINGS ,CONCLUSION AND RECOMMENDATIONS

#### 6.1 Major Findings

Followings are some of the highlights of key findings:

- While Brahmans, Chhetries and other minorities were the local inhabitants in this VDC .Chhetries 45% were head in installing the system . Brahmans 35% were second to chhetries followed by Sarki and Damai.
- The maximum Households (30.07%) had involved in farming.
- The average family size of the sampled Households (40 Households) had seven person per family.
- Out of total respondents 26.87% were found to be under SLC and remaining were above SLC.
- Maximum Households (23.32%) had age group of 20-30 years.
- Survey of the total annual income shows that maximum Households(30%) had the annual income 90-1 lakh.
- Survey shows that majority of the people were farmer and minimum were teachers.
- Maximum households 57.5% had food sufficiency for 12 months and more.
- 79% of the respondents replied that agriculture as source of income.
- Most of the respondents had kachhi house with stone and zink roof they possessed about 75% and remaining 25% respondents had house with kachhi wall and thatched roof.
- Almost 60% households had replied that they clean the ICS monthly and 25% said that they clean chimney in every 2 months.
- 87.5% Households had experienced very good environmental condition. 95% experienced less smoke emmission in the kitchen which has helped the kitchen environment to be smoke free and healthy. All of respondents replied that it is

time saving and has less fuel wood consumption compare to Traditional Cook Stove.

- The maximum Households(87.5%) had been increased their household activities ,have more time for study hour of the children, women have more time to engage in other productive sectors.
- 75% said that the system was very useful for the Households.
- 75% respondents were facing the eye related problem with Traditional Cook Stove.
- Maximum households (75%) had not any problems in running ICS, 5% households had maintenance problems.
- Maximum Households (62.5%) had experienced cooking sufficiency.
- The 84.5% Households were satisfied with the promoters and promoting organizations. 5% Households were not satisfied because there was no provision of frequent follow up mechanism and needed trainings.

## **6.2 Conclusions**

The development and dissemination of Improved Cooking Stoves is reasonably favorable in many parts of the country. In the many areas of Nepal like Thanapati VDC, ICS is the only possible source of energy. It has been able to make substantial social impact in this VDC. Installation of ICS has improved household and household environment. It has been proved very useful for women and the girl. Because of deforestation women have been facing the problem of fuel wood. So ICS has brought significant change in lives of women as it has saved time, energy and labour of the house wives and girl children. The improved stoves used in study area , have a effective means reducing firewood conservation and lessening the pressure on forest resorts. However th knowledge of ICS and its use in the study area is limited.

In spite of long history of stove programs and efforts of the government and development organizations towards mass dissemination of biomass stoves in Nepal lack of awareness on impact of traditional stoves on their health, workload as well as environment and the low income of the people are the major factors behind the slower rate of ICS spread. Improved Cooking stoves has to be disseminated in a very massive

scale by the variably practically making all the fuel wood burning households its prime target in order to effectively realized its proven long range benefits of environmental conservation , improvement in health and sanitation conditions and reducing in woman folk's drudgery.

For short run energy conservation in Nepal improve cooking stoves have the vital role. It directly address the urgent problems of deforestation and reducing domestic firewood scarcity as well as other health related problems due to excess smoke inhalation . They do not require complex technology and high investment. However, the users of ICS in Nepal including Thanapati VDC Nuwakot district has so far been negligible . A major difficulty is the adoption and dissemination which meet local traditions. If ICS are developed considering user characteristics and regional differences, they help to reduce pressure on the forest and fuel crisis.

More than half of the population is covered by Female even, they remain confined to their traditional roles like involvement only in households chores, fetching water ,fodder, bearing children and farming. Women of Nepal have faced various problems which are centuries old, they suffer much oppression,suppression rural areas.

On the economic view, ICS installation has not just helped in saving the fuel wood but it has opened new economic oppertunities in this VDC as they have a bit more leisure time which can be spent in caring of their children and they can give more time in farm activities and also can be involved in other income activities like Knitting/weaving, alcohol making etc.

After the installation of ICS, majority of the households have relieved from above mentioned problems. All of those who complained about nose running, chest pain, and TB got their condition improved drastically after ICS installation.

All respondents has been very positive attitude towards ICS installation however they have little technical knowledge of the technology . For the promotion and development of ICS technology, the baseline information of Thanapati VDC of Nuwakot district has been of great helped. Therefore, related institutions need to provide awareness of subsidy for poor people to install ICS. Most of the people of Thanapati VDC are ready to adopt ICS.

## 6.3 Recommendations

After the baseline information analysis , the following recommendations are given:

1. ICS is the easy source of cooking where the affordability of commercial fuel is a distant dream. Therefore, the cost of the system should be reduced.
2. Subsidy has the main promoting factor for ICS installation especially for the poor dalits (who can not afford). Therefore the provision of subsidy should be provided by the government to them so that they could also enjoy the energy efficient technology.
3. It should be note worthy to create public awareness among the general people for the dissemination of the system installation.
4. There should be proper and clear implementation policy for development and alternative energy.
5. Appropriate design of ICS is necessary for large family and also for cooking livestock feed.
6. Promotion and development of ICS in the rural parts of Nepal like Thanapati VDC is very essential. For this different awareness programs such as workshop ,seminars and training programs are required in one hand and on the other hand ICS programs need to be integrated with income generation programs.
7. Some of the problems are related to design of ICS itself; especially small potholes and difficult to replace the broken parts so the users should be trained in maintenance and repair by themselves.
8. Some of the institutinal problems are related to awareness campaign, training to local promoters and women's empowerment and participation in the program of ICS.
9. People of Thanapati VDC had a little knowledge on adverse effect of deforestation on environment. Therefore, awareness and training programs are to be promoted.

All the above mentioned activities could surely promote the rapid expansion of the system.

## **6.4 Lessons Learned**

The national ICS program is one of the examples of very successful ICS dissemination program. The lessons learned from this program as mentioned below can be incorporated in other programs for effective and successful program delivery.

- Demand generation from the community members themselves is very important for acceptance of the technology and its sustainability. This can only be achieved through effective information dissemination and awareness development activities, which should be an integral program component.
- Involvement of local organizations in ICS dissemination and their capacity building is essential for mass scale up of ICS without too much external supports.
- Development of technical service providers or promoters at local level create an opportunity for self employment at local level and will continue to provide monitoring and technical backstopping which is essential for mass distribution of ICS.
- A flexible, pro-active and effective implementation approach such as focus on awareness campaign, skill and transfer of ICS making know how to local promoters, subsidy less ICS dissemination, integration with kitchen improvement and other rural development activities and emphasis on follow up and monitoring process is essential for sustainable ICS dissemination.



## REFERENCES

- AEPC (2000). *An Introduction to Alternative Energy Technology in Nepal*.
- CBS. (2001). *Population of Nepal (For Central Development Region)* Kathmandu His Majesty's Government.
- CFDP. (1984). *Introduction of Improved Stoves for Domestic Cooking in Nepal*. Field Document No. 10, Kathmandu, Nepal
- Clark, R.(1985). *Wood stove, Dissemination*, Proceeding of the Conference Held at Wolfheze, Netherlands. Intermediate Technology Publication, London.
- ..... (2000). *Inventory of ICS in Nepal*. Kathmandu, Nepal.
- CRT, (1999). *Inventory of ICS Activities in Nepal*, Kathmandu, Nepal.
- District Profile (2063). District, Profile of Nuwakot. Central Bureau of Statistics, Kathmandu, Nepal.
- ..... (2003). *The Tenth Plan (1992-1997)*. Kathmandu: His Majesty's Government.
- ..... (2006). *An Introduction to Alternative Energy Technology in Nepal*. Government of Nepal.
- Economic, Survey (2004/ 05). *Ministry of Finance*, Economic, Survey: Kathmandu, Nepal.
- ..... (2000). *Subsidy for Renewable Energy*. Lalitpur, His Majesty's Government of Nepal.
- ESAP, (2006). *Annual Report on ICS Dissemination*. Government of Nepal, Kathmandu.
- Goldemberg, J. (1996). *Energy, Environment and Development*, U.K.: Earthscan.

- Joshee, B.R.(1986). *Improved Stoves in Minimization of Firewood Consumption in Nepal: Forest Research Paper Series No.7*, Kathmandu. HMG-USAID-GTZ-IDRC-WINROCK INTERNATIONAL.
- MoF. (2005). *Economic Survey 2004/5*. Kathmandu: Ministry of Finance.
- MoF. (2006). *Economic Survey 2005/6*. Kathmandu: Ministry of Finance.
- NPC. (1982). *The Sixth Plan (1981-1985)* . Kathmandu His Majesty's Government.
- ..... (2005/6) *Ministry of Finance, Economic, Survey*: Kathmandu,Nepal.
- Pant, P.R.(2009). *Social Science Research & Thesis Writing*, Kathmandu: Buddha Academy.
- Prasad, R. (1982). *Cook Stoves Study*, Indian Institute of Technology, New Delhi.
- Saghir, (2005). *Energy &Poverty :Myths, Links ans Policy Issues*, Energy. Energy and Mining Sector Board,NGO, May, 2005.
- Shakya, G.R. (1985). *Energy Development and Sub- Project Implementation Activities*. In RCUP Evaluation Brifing Book ,Kathmandu : USAID Mission to Nepal.
- Sharma Bk. (2038). *Sadharan Dhuwan Naaune Chulo*. World Neighbourers Kathmandu, Nepal .,
- Sulpya, K.M. (1986). *Household Energy and Integrated Extension of ICS*. RECASTA Experience paper presented at the International Seminar on Clay for Stoves, Yogyakarta,Indonesia.
- Thapa,Rajan (2006). *Biomass Stove Promotion in Nepal : Prospects and Challenges*: A paper presented to the FIRST NATIONAL Conference on Renewable Energy Technology for Rural Development, Oct-Nov,2006, CRT/N Kathmandu.
- Trust,(2006). *A Report on Refresher Training for local promoters on ICS constructions and Kitchen Management*, Jawalakhel,Lalitpur.

WECS (1994). Energy Sector Synopsis Report: Perspective Energy Supporting Document No.1, water & Energy Commission Secretariat, Kathmandu.

WECS (2006). *Energy Synopsis Report No: 7, Seq no. 489, Water and Energy Commission Secretariat*, Kathmandu.

Wood, S.T. (1987). *Assessment of Cook Stove Programme in Nepal*, VITS USA.

Wood, S.T. (1987). *Assessment of Cook Stoves Program in Nepal*, VITA USA.

[www.aepcnepal.org](http://www.aepcnepal.org)

[www.energyhimalaya.com](http://www.energyhimalaya.com)

[www.energysourceguides.com](http://www.energysourceguides.com)

[www.retsasie.ait.ac.th](http://www.retsasie.ait.ac.th)

## APENDEX 1

### Some Guiding Semi-structured Questionnaires

#### Group-A

1. a Name of the head of the household.....  
District..... VDC..... Ward No..... village  
b. Sex..... c .Education..... d. Occupation.....
2. Name of the Respondent .....
3. Relation of Respondents with the head of the household.....
4. Information of Respondents
  - a. Age..... b. Sex..... C Caste.....
  - d Oualification..... e. Occupation.....
5. Types of House(Wall)
  - a. Pakki (Made up of brick and cement)
  - b. Made up of stone and mud with thatched roof
  - c. Kachhi( Made up of hay& sticks)
  - d. Wooden( Made up of wood)
  - e. Others.....
- 5.1 Type of Roof
  - a . Black Slate b. Zink c. Thatched d. Others.....
- 5.2 Facilities Available in the House
  - a. Biomas b. Toilet c. Tap d. Television e.Electricity
6. Land wonership
  - a.Culticable land .....ropani, aana, paisa, kattha
  - a. Have you given your land cultivated by others?
    - a. Yes b. No
  - b. Are you using any others ‘ land for cultivation?
    - a. Yes b. No

7. What is the main occupation of the family members?  
 a. Farming    b. NGO/INGO    c. Teaching

8. Social Information of Family Members

S.N.	Name	Age	Sex	Educational Status
1.				
2.				
3.				
4.				
5.				
6.				
7.				
8.				
9.				
10				

**Group-B**

**Utility of ICS**

1. Do you have any idea regarding ICS?
  - a. Yes                    b. No
  - a. If yes, from where.....?
  - a. Media    b. Textbook    c. Neighbours    d. NGOs
  - f. Social Immobilizers    f. Village Leaders
  - g. If any other .....
  
2. What type of Improved Cook Stoves do you know?
  - a. One pot hole    b. Two pot hole    c. Three pot holes
  - d. With chimney    e. Without chimney
  
3. Have you ever participated in the programs of ICS?
  - a. Yes                    b. No

c. If yes, please specify.....

4. What type of ICS are you using ?
  - a. One pothole
  - b. Two pothole
  - c. Three pothole
  - d. Multipurpose
  - e. Others .....
  
5. What type of cook stove was used before installation of ICS?
  - a. Mud Stove
  - b. Kerosene Stove
  - c. LPG
  - d. Stone stove
  - e. Biogas
  - f. Others
  
6. When did you installed this stove ? How long have you been using the ICS?  
Years ..... Month .....
  
7. Do you use other cooking stoves in addition to this ICS?
  - a. Yes
  - b. No
  
8. How many hours do you usually use this stove in a day?
  - a. 1-2 hours
  - b. 2-3 hours
  - c. 3-4 hours
  - d. Others.....
  
9. What items are cooked in this cook stove?  
please specify .....
  
10. Is there any difficulty to cook any items in ICS?
  - a. Yes
  - b. No
  
11. For which purpose do you use this stoves except cooking food?  
Please specify.....
  
12. How often do you clean the chimney?
  - a. weekly
  - b. Bimonthly
  - c. Monthly
  - d. Seldom
  - e. Never
  
13. Are there any Problems seen in ICS so far?
  
14. Does this stoves run throughout the air ?

### **Impact Analysis**

15. If you are using ICS , what are the positive aspects of this stove?

- a. Less consumption of fuel wood    b. Time saving    c. Improved kitchen management
- d. Less smoke Emmission    e. Improved health conditions    f. Othres

16. Do you use the saved time in any of the activities ?

- a. Yes    b. No

If yes, specify.....

Health Impact

17. Did you have any health problems caused by the released smoke of traditional cook stoves ?

- a. Yes    b. No

If yes, please specify the problems.....

18. have you felt any of the improvment in the health problems upon the installation of ICS?

- a. Yes    b. No

If yes would you tell some of the improvements seen brought by ICS?

19. Is there any reduction in annual treatment cost after installation of ICS?

- a. Yes    b. No

If yes,specify.....

### **Fuel wood Consumption**

20. Did you find any difference in the fuel wood consumption between these two stoves ?

- a. Yes    b. No

If yes, specify in average.....

Fuel wood consumption in the traditional cook stoves , in a month.....

Fuel wood consumption in the improved cook stoves , in the month.....

### **Kitchen Mnagement**

21. What improvments are seen in the kitchen after the installation of ICS?

- a. Reduction in smoke emission    b. Clean utensils    c. Tidy clothes    d. Clean kitchen
- e. Others.....

### **Affordability**

22. How many people were involved in the installation of ICS?.....

ICS Promoters    Day    Wage





- a. Maintenance
- b. Problems of appropriate size
- c. Space heating
- d. Others

34. Can you make it yourself ?

- a. Yes    b. No

If no, how much you spend to make it?

- a.                    b.

35. Have you got any operational and maintenance training from the promoters ?

- a. Yes            b. No

36. Are you satisfied with this ICS?

- a. Good    b. Fair    c. Excellent    d. Bad

37. Do you see any problems after ICS ?

38. What are your suggestion for improvement?

**APPENDEX 2**



*Pic. 1: Improved Cooking Stove*



*Pic.2 :Researcher in field site*



*Pic.3 Field Visit*



*Pic.4 : Chimmney*



*Pic.5 : Baffel*

# Map of Thanapati VDC

